

ACE20 explosionproof variable frequency drives

Utilizes Allen-Bradley PowerFlex 700 drives

Cl. I, Div. 1 & 2, Groups B, C, D (UL)
Cl. I, Div. 1 & 2, Groups B^A, C, D (cUL)

NEMA 3, 4X^B, 7BCD
Raintight
Wet locations

6C

The only explosionproof VFD solution utilizing a NEMA 7 classified enclosure

ACE20 explosionproof VFDs are highly flexible AC drives designed specifically for hazardous area locations. These drives can be mounted next to the motor in the classified area, providing significant installation cost savings - along with the traditional VFD benefits of energy savings, speed and torque control and system diagnostics.

This innovative product features the first ever NEMA 7 enclosure with active cooling, allowing the solution to be rated Class I, Divisions 1 and 2. It is designed to match the high requirements of pumps, compressors, fans, separators and mixers in the following process industries:

- Oil and gas/refineries
- OEM skid builders
- Petrochemical
- Water/waste water
- Pharmaceutical
- Food and beverage manufacturing

Applications:

- For speed control of pumps, compressors, fans, conveyors, separators, mixers and other process equipment
- Designed to meet the high reliability and safety requirements of process industries such as oil and gas, chemical and mining

Features:

- ACE explosionproof VFDs are installed 'on-machine' inside the hazardous areas, eliminating expensive, complicated installations
- There is no need to run long lines of conduit and motor cable, dig up roadways and sidewalks, navigate around obstacles and hazards or build off-site control rooms in non-hazardous areas to house VFD clusters
- Reflected Wave Syndrome is eliminated due to short motor cable runs

Certifications and compliances:

UL classified:

- Class I, Divisions 1 & 2, Groups B, C, D

cUL classified:

- Class I, Divisions 1 & 2, Groups B^A, C, D

UL standard:

- UL1203

Environmental ratings:

- NEMA 3, 4X^B, 7BCD
- Raintight
- Wet locations

Operating temperature range:

- 0°C to 50°C (32°F to 122°F)

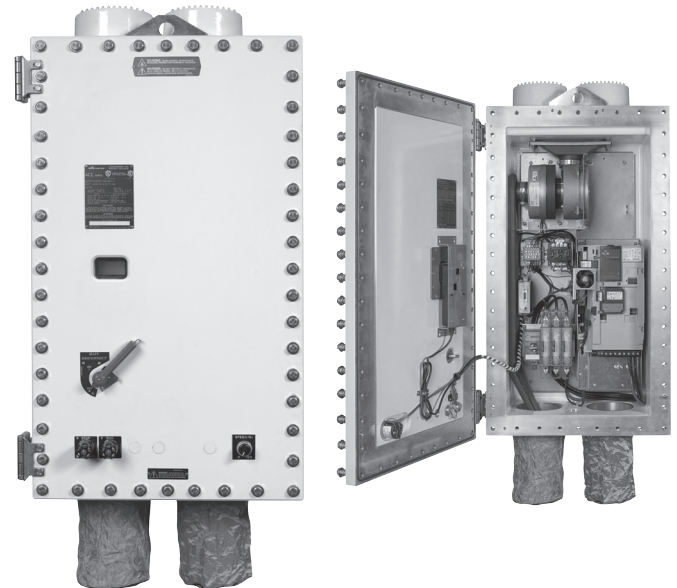

Standard materials and finishes:

- Body and cover – copper-free aluminum, epoxy powder coated
- Operating handle – copper-free aluminum, epoxy painted
- Window – tempered soda lime glass
- Blower – aluminum, natural
- Filters – stainless steel, natural
- Pre-filters – stainless steel, natural
- Disconnect – stainless steel, natural
- Shroud – copper-free aluminum, epoxy painted
- Cover hinges, bolts, washers and springs – stainless steel, natural
- Internal brackets – stainless steel, natural
- Manifold and intake – EPDM rubber, natural

Horsepower ratings:

- Available up to 50 HP

VFD system specifications:

- Allen-Bradley® PowerFlex 700® low voltage, compact AC drives

^A 5 HP and below listed for Group B.

^B For NEMA 4X, please contact factory.

ACE20 explosionproof variable frequency drives

Utilizes Allen-Bradley PowerFlex 700
drives

Cl. I, Div. 1 & 2, Groups B, C, D (UL)
Cl. I, Div. 1 & 2, Groups B, C, D (cUL)

NEMA 3, 4X, 7BCD
Raintight
Wet locations

6C

Variable Frequency Drive (VFD) in explosionproof enclosure allows installation in classified area, providing significant installation savings.

6C

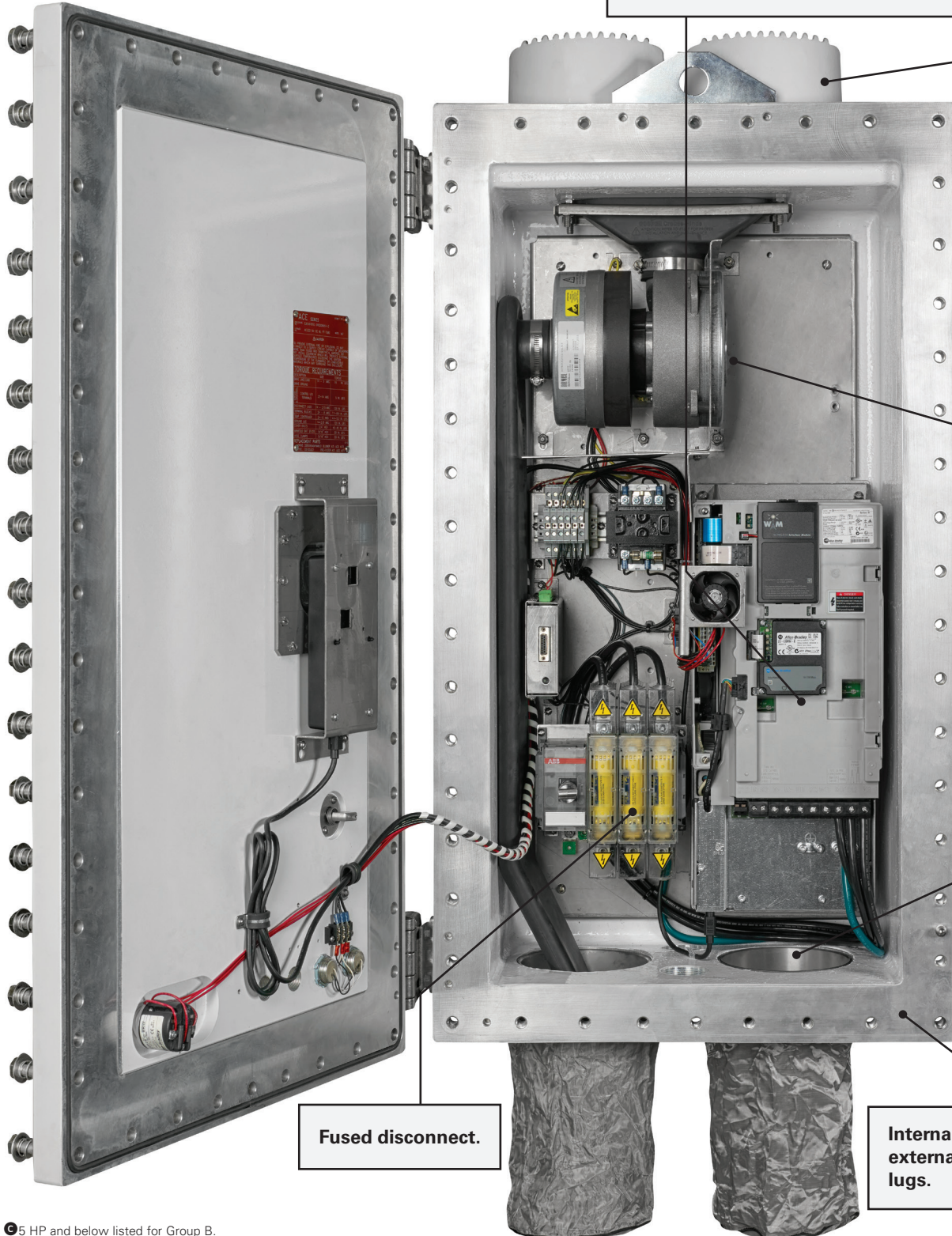

Fused disconnect.

Internal and external grounding lugs.

Ⓞ 5 HP and below listed for Group B.
Ⓧ For NEMA 4X, please contact factory.

ACE20 explosionproof variable frequency drives

Utilizes Allen-Bradley PowerFlex 700 drives

Cl. I, Div. 1 & 2, Groups B, C, D (UL)
Cl. I, Div. 1 & 2, Groups B^e, C, D (cUL)

NEMA 3, 4X[Ⓞ], 7BCD
Raintight
Wet locations

6C

Shroud[Ⓞ]

covering top filters maintains NEMA 4X rating.



Stainless steel, captive, triple lead quick release spring loaded bolts install faster and provide clear indication that the cover bolts are fully retracted from the body.

Stainless steel hinges provide convenient and easy access to enclosure interior.

Explosionproof window allows for viewing of the VFD interface module LCD screen.

Heavy duty blower[Ⓞ] creates airflow through the enclosure, allowing VFD to operate in ambient temperatures up to 50°C.

Filters[Ⓞ]

in top and bottom of enclosure allow airflow into and out of the enclosure, cooling the VFD and eliminating risk of overheating.



Pre-filter screens[Ⓞ]

eliminate clogging of the primary filters, ensuring reliable and consistent airflow. Pre-filter screens can be easily removed and cleaned without shutting down operations.



Explosionproof pilot lights provide run, stop and fault indication.

Optional potentiometer, pushbuttons and selector switches.

Enclosure epoxy painted for superior corrosion resistance.



6C

[Ⓞ] 5 HP and below listed for Group B.

[Ⓞ] For NEMA 4X, please contact factory.

[Ⓞ] Heavy duty blower, shroud, filters and pre-filter screens not included with units containing 1.5 to 5 HP VFDs.

ACE20 explosionproof variable frequency drives

Utilizes Allen-Bradley PowerFlex 700 drives

Cl. I, Div. 1 & 2, Groups B, C, D (UL)
Cl. I, Div. 1 & 2, Groups B, C, D (cUL)

NEMA 3, 4X, 7BCD
Raintight
Wet locations

6C

Ordering information:

Horsepower rating

Base cat. #	Nominal HP (kW)	Max. disconnect rating amperage	Disconnect fuse type	Enclosure size	460V input rating amperage	Max. output rating amperage ^①	Power loss (watts) ^②	Temperature rating	VFD manufacturer cat. #
ACE20 1	1.0	30	J	1	1.6	2.1	63	T6	20BD027A0AYNANCO
ACE20 2	2.0	30	J	1	2.6	3.4	76	T6	
ACE20 3	3.0	30	J	1	3.9	5.0	93	T6	
ACE20 5	5.0	30	J	1	6.9	8.0	164	T6	
ACE20 7	7.5	30	J	2	9.5	11.0	594	T4A	
ACE20 10	10.0	30	J	2	12.5	14.0	618	T4A	20BD027A0AYNANCO
ACE20 15	15.0	60	J	2	19.9	22.0	726	T4A	
ACE20 20	20.0	60	J	2	24.8	27.0	794	T4A	
ACE20 25	25.0	60	J	2	31.2	34.0	841	T4A	20BD065A0AYNANCO
ACE20 30	30.0	60	J	2	36.7	40.0	859	T4A	
ACE20 40	40.0	100	J	2	47.7	52.0	1010	T4A	
ACE20 50	50.0	100	J	2	59.6	65.0	1117	T4A	

Part number example ACE20 50-CE-PT-FJ70

ACE20 50 – **CE** – **PT** – **FJ70**

Horsepower rating

ACE20 50 Allen-Bradley VFD with 50 HP rating

Options (see below)

CE Ethernet communications
PT Potentiometer

Current rating

FJ70 Fuse (65A requirement + 5A for blower, rounded up to 70)

Current rating for Bussmann fuses

FJ ← NOTE: Add 5 amps to your requirements to account for cooling system blower and round up to the nearest increment of 5
Fuse type J Current rating

Options

Communication modules

Suffix	Description
CP	Profibus
CD	Devicenet
CC	CAN open
CM	Modbus
CE	Ethernet

Additional options

Suffix	Description
PT	Potentiometer
RR3	Hand-off-auto switch ^①
PB23	Pushbutton start-stop ^①
600	600 VAC VFD

Note: 600 suffix option can only be used for ACE20 units with nominal HP of 5 or less.

Replacement part kits

Cat. #	Description
ACE KIT 1	Pre-filter and hardware (one-piece)
ACE KIT 2	Filter assembly (one-piece)
ACE KIT 3	Blower, manifold and hardware (one-piece)
ACE KIT 5	Temperature controller (one-piece)
ACE KIT 7	3/8" glass window
ACE KIT 9	Shroud replacement kit

① 5 HP and below listed for Group B.

① For NEMA 4X, please contact factory.

① De-rating may be required to account for specific environmental conditions (high ambient temperature, altitude, etc). Contact factory for de-rating information.

② When not installed in a well-ventilated environment, provisions must be made to account for heat generation to ensure proper operation of the device.

② RR3 and PB23 cannot be ordered together.

ACE20 explosionproof variable frequency drives

Utilizes Allen-Bradley PowerFlex 700 drives

Cl. I, Div. 1 & 2, Groups B, C, D (UL)
Cl. I, Div. 1 & 2, Groups B, C, D (cUL)

NEMA 3, 4X, 7BCD
Raintight
Wet locations

6C

Dimensions:

Enclosure size 1 (1 to 5 HP)

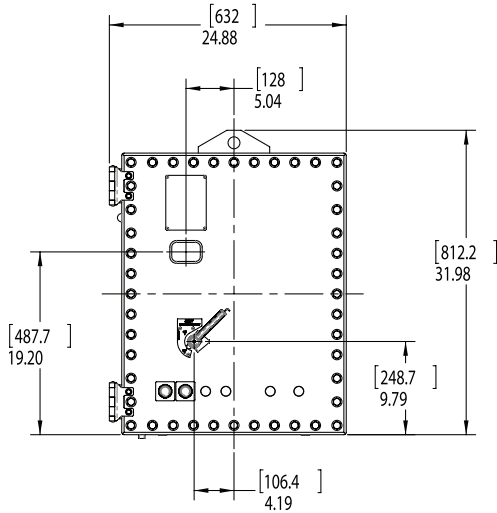

Note: Units containing 1 to 5 HP VFDs do not require filters

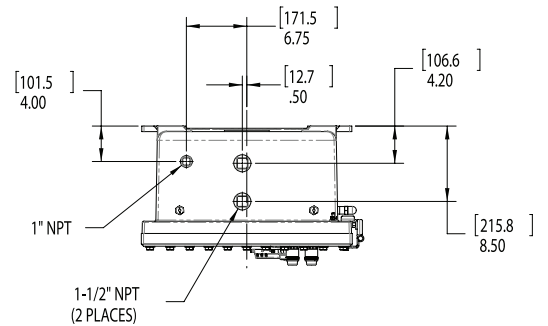
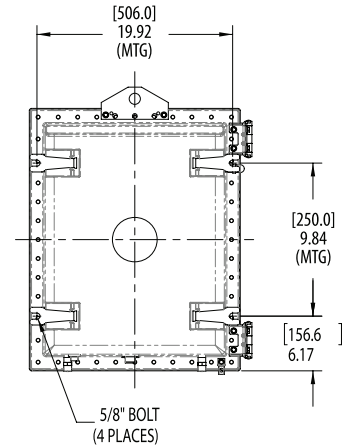

Enclosure size 2 (7.5 to 50 HP)

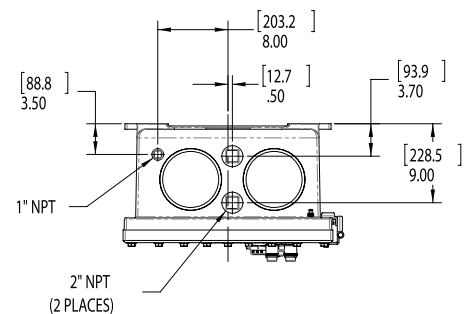
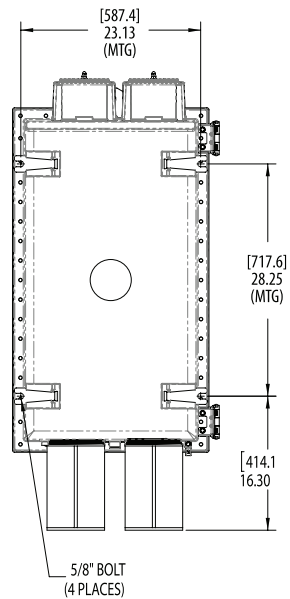
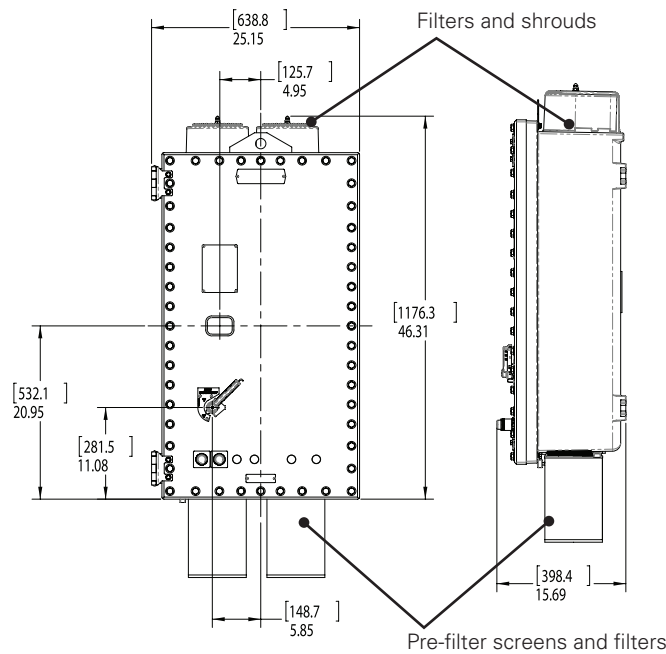

M 5 HP and below listed for Group B.
N For NEMA 4X, please contact factory.