

Monitoring the integrity of the engine generator remote start circuit in an emergency system

Charlie Hume
Product Manager
Automatic
Transfer Switches
Eaton

This paper provides an overview of recent changes in the National Electrical Code® pertaining to a generator remote start circuit for use in an emergency system and provides a code-compliant solution that can be implemented with one or more transfer switches using common technology.

Changes in the National Electrical Code

With the publication of the National Electrical Code 2017 edition (NEC 2017), new language was introduced in “Article 700.10(D)(3) Generator Control Wiring” that resulted in additional requirements for a generator remote start circuit installed between transfer switch equipment and an emergency generator.

The [initial publication of NEC 2017](#) introduced the following new requirements:

- The integrity of the generator control wiring shall be continuously monitored
- Loss of integrity of the remote start circuit(s) shall initiate visual and audible annunciation of generator malfunction at the generator local and remote annunciator(s) and start the generator(s)

In practice, the field application of these new requirements led to adverse impact and confusion, which in turn prompted the need for corrective action.

On August 14, 2018, the National Fire Protection Association (NFPA) issued a [Tentative Interim Amendment](#) (TIA 17-17) to NEC 2017, with an effective date of September 3, 2018, intended to provide prescriptive requirements that are more concise, practical, and enforceable. The amended requirements are as follows:

- **The integrity of the generator remote start circuit shall be monitored for broken, disconnected, or shorted wires**
- **Loss of integrity shall start the generator**

It should be noted that the TIA has eliminated the requirements for “continuously monitored” and “initiate visual and audible annunciation of a generator malfunction at the generator local and remote annunciator(s).”

Although not part of this document scope, the TIA included an identical amendment to “Article 695.14(F) Generator Control Wiring Methods” for Fire Pumps.

The TIA requirements bulleted above have also carried forward into the National Electrical Code, 2020 edition (NEC 2020) without modification, providing a consistent approach to equipment installation as states and municipalities migrate from earlier NEC editions.



Powering Business Worldwide

Traditional two-wire remote start circuit

Historically, general practice has been for the transfer switch to send the engine-generator a start signal by closing a contact (Figure 1) in a two-wire start circuit when the normal power source (e.g., utility) becomes unavailable. When the normal power source is available, the contact remains open (Figure 2).



Figure 1. Transfer switch start contact closes signaling an engine start when the normal power source becomes unavailable

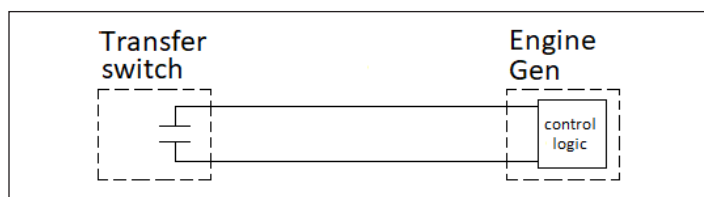

Figure 2. Transfer switch start contact remains open when the normal power source is available

This simple approach has been used effectively for decades but what happens if the integrity of the two-wire circuit becomes compromised? If the wires are shorted (Figure 3), the engine-generator could start when the normal power source is available.



Figure 3. Shorted wire condition when normal power source is available

If the wires are broken (Figure 4) the engine-generator control logic may not detect a contact closure at the transfer switch (signaling a start) when alternate power is needed.

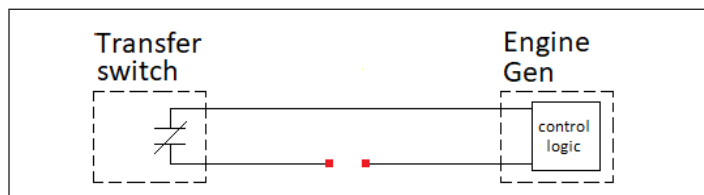

Figure 4. Broken wire condition when normal power source is unavailable (transfer switch signals start)

If the wires become disconnected (Figure 5) at the transfer switch or engine-generator, the engine-generator control logic may not detect a contact closure at the transfer switch (signaling a start). A disconnected condition could occur unintentionally during routine service or from mechanical stress at a wire termination point (terminal block or connector) within the transfer switch assembly or engine-generator enclosure.

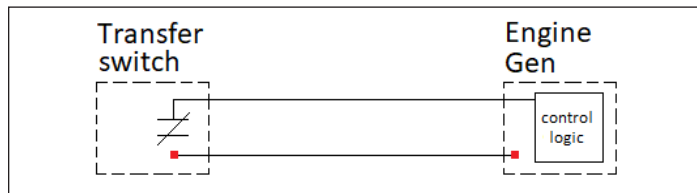

Figure 5. Disconnected wire condition (at transfer switch or engine-generator) when normal power source is unavailable (transfer switch signals start)

So how can this simple approach be enhanced to increase reliability while minimizing cost and complexity?

Solution: Three-wire remote start circuit

Many transfer switch models in the marketplace are equipped with a set of normally open (NO) and normally closed (NC) switch contacts dedicated to signaling an engine-generator start. These contacts are commonly provided as a single Form C type (single-pole double-throw) or alternatively as a Form A and Form B type pair (single-pole single-throw) (Figure 6).

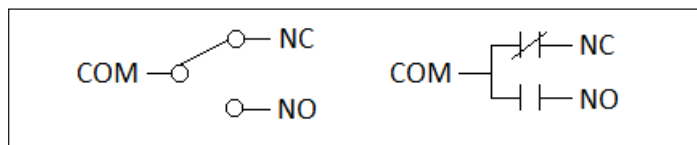

Figure 6. Electrical symbols for single-pole double-throw (SPDT) Form C contacts (NC, NO) with common terminal (COM)

In either case, the traditional two-wire arrangement can easily be enhanced by adding another wire and utilizing both the NO and NC contacts. The result is a three-wire remote start circuit that can be monitored for all the abnormal wire conditions outlined in the NEC—broken, disconnected, and shorted—and a loss of integrity will start the engine-generator (Figure 7).

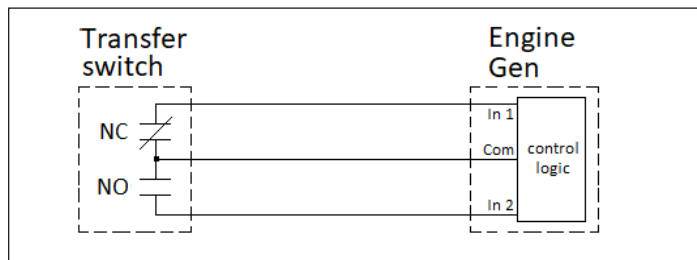

Figure 7. Three-wire start circuit (Form C) when normal power source is available. Single transfer switch and single engine-generator

Monitoring the integrity of the engine generator remote start circuit in an emergency system

Monitoring for start status and circuit integrity is performed by the engine-generator control logic when the engine is off or running, but unlike the traditional two-wire arrangement, the three-wire circuit requires two inputs at the engine-generator control logic including a common (Com). Each input at the engine-generator monitors a single contact at the transfer switch for a change in logical state (position). As illustrated in **Figure 7**, Input 1 (In 1) monitors the NC contact and Input 2 (In 2) monitors the NO contact. Eaton transfer switch controllers close the NO contact and open the NC contact to signal an engine start.

The logical state of the NO and NC contacts at the transfer switch will always be in opposition to each other (closed-open or open-closed) because of the Form C single-pole double-throw construction. As a result, if both engine-generator control logic inputs sense identical logical states (open-open or closed-closed), a loss of circuit integrity will be detected due to broken, disconnected or shorted wires and an engine start will be initiated. Examples can be seen in **Figure 8** and **Figure 9**.

In some instances, shorted or broken/disconnected wires may not be detected until the transfer switch signals a start that occurs when the normal power source becomes unavailable or when conducting periodic testing (mandated in Article 700 of the NEC). Specific conditions can include a shorted wire associated with the NC circuit loop (**Figure 10**) or a broken/disconnected wire associated with the NO circuit loop (**Figure 11**). With either condition, the engine-generator control logic inputs will sense identical logical states and an engine start will be initiated.



Figure 8. Three-wire start circuit when normal power source is available. Shorted wire condition at NO loop. Identical logical states (closed-closed) sensed by engine-generator control logic inputs

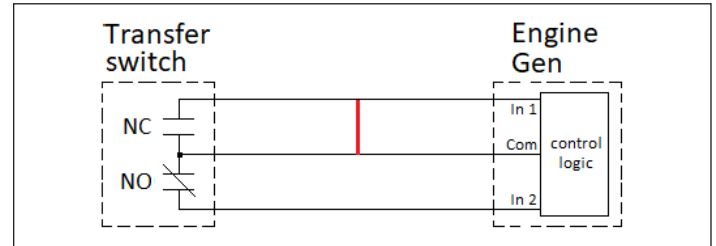

Figure 10. Three-wire start circuit when normal power source is unavailable (transfer switch signals start). Shorted wire condition at NC loop. Identical logical states (closed-closed) sensed by engine-generator control logic inputs

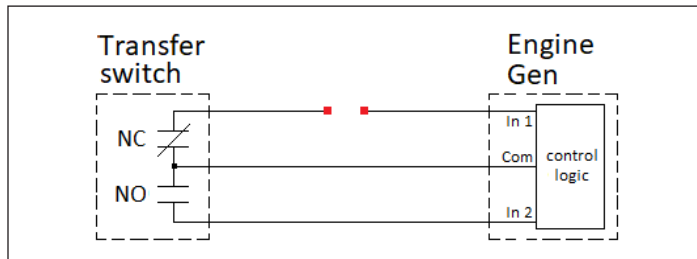

Figure 9. Three-wire start circuit when normal power source is available. Broken/disconnected wire condition at NC loop. Identical logical states (open-open) sensed by engine-generator control logic inputs

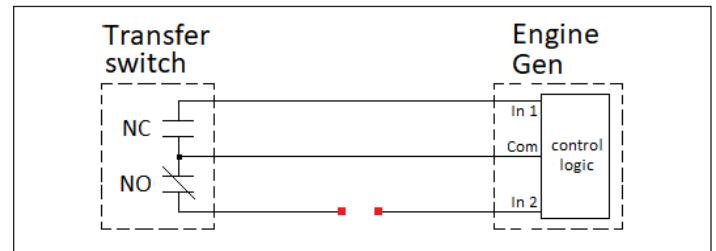

Figure 11. Three-wire start circuit when normal power source is unavailable (transfer switch signals start). Broken/disconnected wire condition at NO loop. Identical logical states (open-open) sensed by engine-generator control logic inputs

A matrix of logical states sensed by the engine-generator control logic inputs are summarized in **Table 1** with corresponding action.

Table 1. Engine-generator control logic inputs (logical state sensed) with corresponding action

Engine Gen (Input 1)	Engine Gen (Input 2)	Corresponding action
Closed	Open	None
Open	Open	Start engine (loss of circuit integrity)
Closed	Closed	Start engine (loss of circuit integrity)
Open	Closed	Start engine

Multiple transfer switches

A three-wire start circuit can also be used when a single engine-generator serves as the alternate power source for multiple transfer switches. Because installation needs can vary based on equipment location and proximity, two wiring scheme drawings (“home-run” and “daisy-chain”) are provided. Electrically, the two drawings are identical. Transfer switch (n) can be removed or duplicated to reflect system size. See **Figure 12** and **Figure 13**.

Summary

As demonstrated, a three-wire remote start circuit solution can be used to meet NEC requirements and includes the following benefits:

- **Simple**—easy to understand and implement
- **Cost-effective**—requires one additional wire compared to a traditional two-wire circuit
- **Reliable**—monitors the entire length of the remote start-circuit end-to-end (transfer switch start contact to engine-generator control logic input) and doesn’t require additional in-circuit components (potential failure points)
- **Compliant**—meets NEC (2017 and 2020) requirements

About the author

Charlie Hume is a product manager within Eaton’s Commercial Distribution Products and Assemblies (CDPA) organization and has a Bachelor of Science in Electrical Engineering. A veteran in the power systems industry, Hume has been involved with new product development, sales, marketing, and application engineering associated with automatic transfer switches and UPS systems.

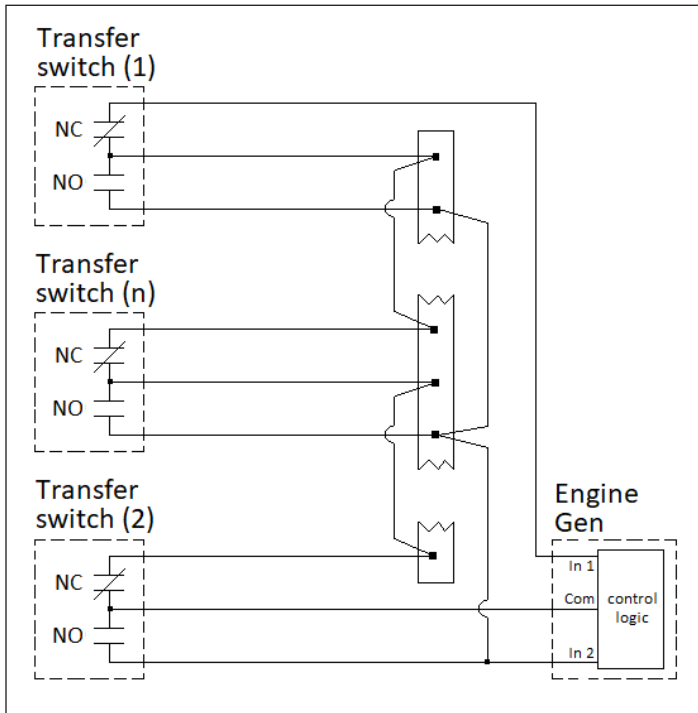

Figure 12. “Home-run” wiring scheme; three-wire start circuit with multiple transfer switches and single engine-generator. Terminal strip shown would be located within or near engine-generator

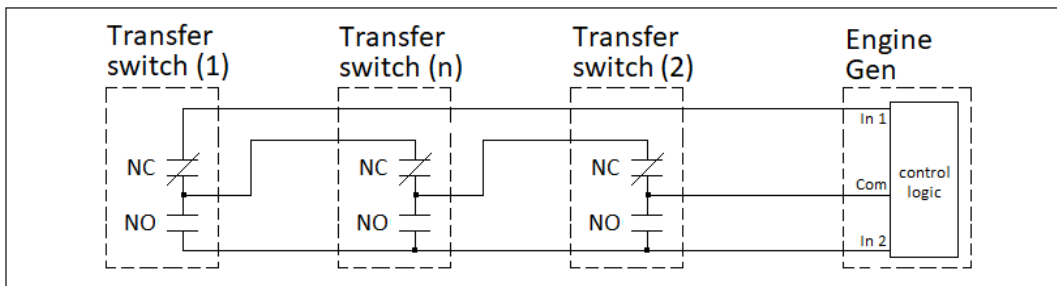

Figure 13. “Daisy-chain” wiring scheme; three-wire start circuit with multiple transfer switches and single engine-generator

Eaton
 1000 Eaton Boulevard
 Cleveland, OH 44122
 United States
 Eaton.com

© 2019 Eaton
 All Rights Reserved
 Printed in USA
 Publication No. WP140002EN / Z23291
 September 2019