

LUMINAIRES MUST BE EARTHED

Connect supply and earth conductors to the three way terminal block marked N, ⊕ & L.

Blue - N
Brown - L
Green - ⊕

Safe Operation

1. Check the rating label for voltage and frequency before connecting this luminaire to the electrical supply.
2. Ensure that the mains supply is switched off when working on this luminaire, whether installing, re-lamping or carrying out any other servicing.
3. Use the correct lamps as initially supplied or as indicated on the ballast label.
4. This luminaire is suitable for mounting in direct contact with non-combustible materials, e.g. Metal, concrete, plaster. It is also suitable for mounting adjacent to normally flammable materials, e.g. Timber, chipboard, providing the top surface is spaced not less than 25mm from such materials. Do not mount luminaire on or close to readily flammable materials.
5. To prevent damage to H.F. Ballasts do not mix H.F. And conventional magnetic Ballasts on the same electrical circuit.
6. Where use in more onerous situations is required, e.g. In part-completed buildings before "drying-out" is completed, or areas where ambient temperatures are outside the normal temperature range, then consult our Sales Office.

Servicing and Disposal

1. At commissioning and handing over of installation ensure that a copy of these instructions is presented to the authority responsible for the operation and maintenance of the luminaires.
2. Servicing, e.g. cleaning, lamp replacement, must only be carried out after the electricity supply has been switched off. It must not be assumed that luminaires with lamps not lit are switched off-always check before servicing.
3. Cleaning should be carried out at regular intervals to ensure that dirt does not accumulate to an extent that will impair the thermal safety of the luminaire. Regular cleaning will also ensure that the optical performance of the luminaires is maintained.
4. Failed lamps and starter switches must be replaced as soon as practicable by lamps and starters of the same type. For electronic start circuits allow **one minute** for the thermal cut-out to re-set before switching on the mains supply.
5. At the end of life the lamp and luminaire are classed as WEEE under directive 2002/96/EC and should be disposed of in accordance with local legislation.

Cooper Lighting and Safety Ltd
Wheatley Hall Road, Doncaster, South Yorkshire, DN2 4NB

Sales	General	Major Projects London	International Sales
T: +44 (0)1302 303303	+44 (0)1302 321541	+44 (0)1992 787999	+44 (0)1302 303250
F: +44 (0)1302 367155	+44 (0)1302 303220	+44(0)1992 787222	+44 (0)1302 303251
E: sales@cooper-ls.com	technical@cooper-ls.com	london@cooper-ls.com	export@cooper-ls.com

K782V

COOPER Lighting

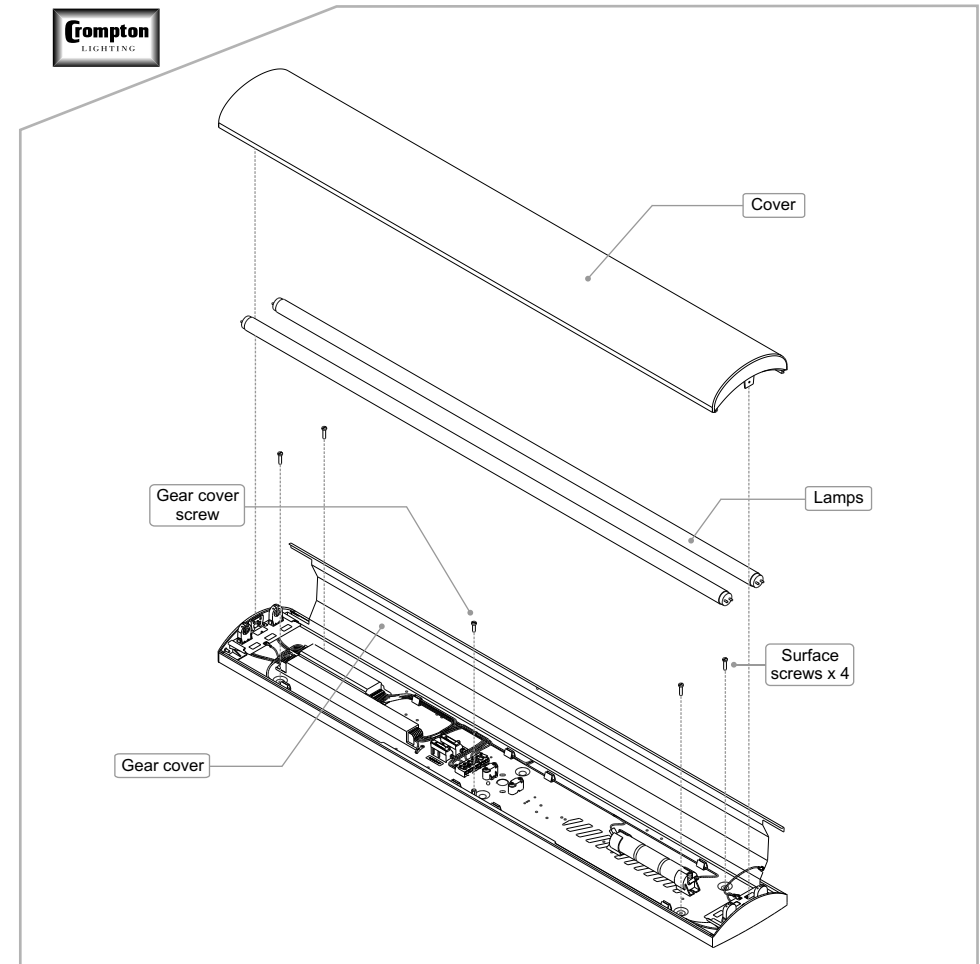

Installation Instructions for:

Varsity

COOPER Lighting

- Product luminaires comply with BSEN60598-1.
- This luminaire has an ambient temperature range of 5°C to 25°C

Assembly

