

Installation Instructions for: Solstar Attachments

With the exception of the wallwash attachment and the semi-recessing ring attachment use a star or Philips head screwdriver and a light tap from a hammer to knock out the 3 attachment tabs (surrounded with a hexagon cutout). Remove only 2 for the wallwash (as marked below) leave the bezel solid for the semi-recessing ring attachment.

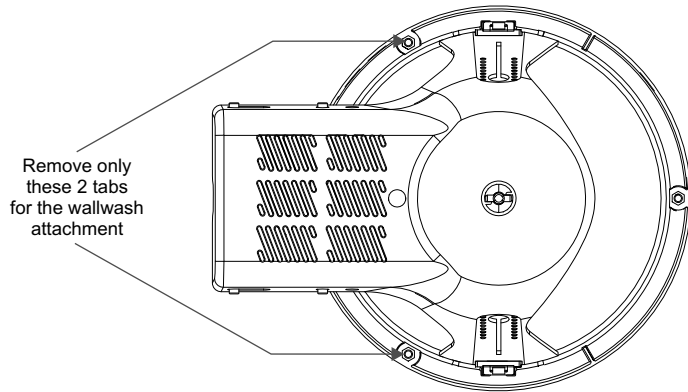

Note: When using any of the attachments apart from the halo glass on emergency luminaires use the LED bracket supplied, hooked over the lamp cutout in the reflector. For the halo glass fit the LED into the bezel as a standard emergency luminaire

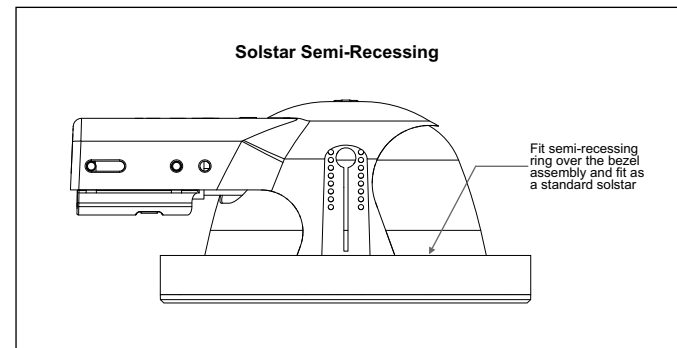
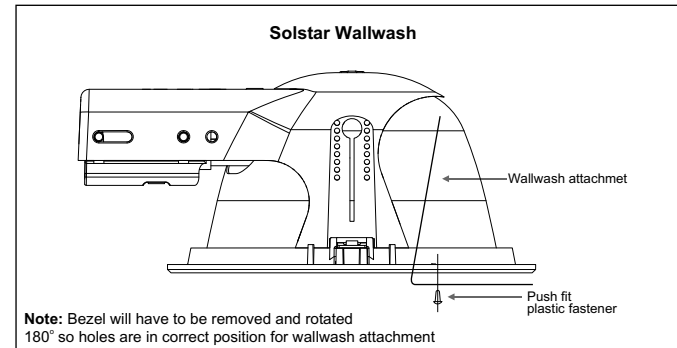
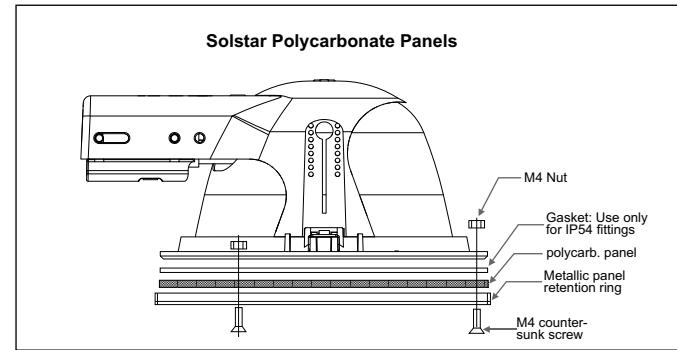
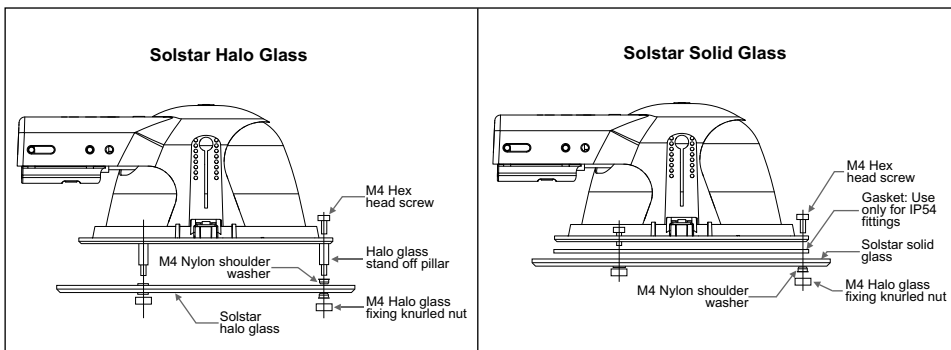

Cooper Lighting and Safety Ltd
Wheatley Hall Road, Doncaster, South Yorkshire, DN2 4NB

Sales	General	Major Projects London	International Sales
T: +44 (0)1302 303303	+44 (0)1302 321541	+44 (0)1992 787999	+44 (0)1302 303250
F: +44 (0)1302 367155	+44 (0)1302 303220	+44(0)1992 787222	+44 (0)1302 303251
E: sales@cooper-ls.com	technical@cooper-ls.com	london@cooper-ls.com	export@cooper-ls.com