

Montaine Rack



The Montaine Rack IP65 high bay is a highly efficient LED luminaire ideally suited to a wide range of industrial applications.

The heavy duty aluminium die-cast construction, combined with the latest LED chip technology and extended operating temperatures, provide the ruggedness and high performance required for modern industrial, warehousing and commercial spaces.

The 50,000 hour, high efficiency LED light source, provides significant cost savings, both in energy (when compared with traditional HID high-bay luminaires) and maintenance.

For installation, the Montaine Rack is supplied with cables and adjustable wall brackets to allow for easy suspension and directional mounting, dependant on the application requirements.

- 3 output options:
 - 60W (6300lm)
 - 120W (13000lm)
 - 180W (20000lm)
- Superior efficacy of up to 110Llm/cW
- Leading high flux LED chips
- 130 x 80 degree beam angle
- IP65 ingress protection rating
- Polycarbonate optic ideal for food preparation locations
- 50,000+ hour life (at L70)
- Extended operating temperature range -40°+50°
- Heavy duty aluminium die-cast construction with textured paint finish & stainless steel fixings
- Microwave sensor versions available
- Compact form factor
- 5 year Eaton warranty

Lamp Options

- 60W, 120W or 180W high flux LED

Materials

- Die-cast aluminium housing
- High transparency polycarbonate optic
- Textured black paint
- Stainless steel fixings

Installation Notes

- Pre-wired supply cable
- Stainless steel fixings
- Adjustable mounting brackets

Options

- Microwave sensor versions available
 - Detection area, time delay and daylight threshold can be precisely set via DIP switch
 - With 1-10Vdc dimming
 - 12m mounting height, 16m area detection range

Specification

To specify state: Montaine Rack IP65 , 5000K 110Llm/cW.
Available in 60W, 120W and 180W (L70 50000hrs), as Eaton's Montaine Rack range part no _____

Photometric Data

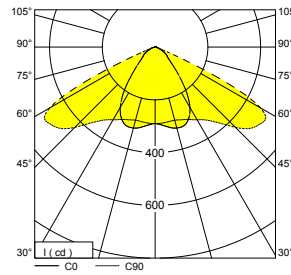

Cat No. R120BLK5KM

R120
LOR 100%
DLOR 100%
ULOR 0%

SHR Nom 1:1.25
SHR Max 1: 1.41

Variant configurations

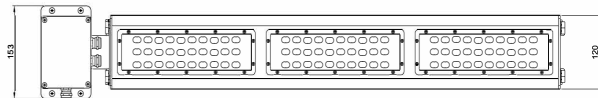

180W (200000lms)

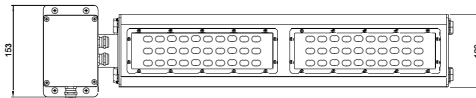

120W (13000lms)

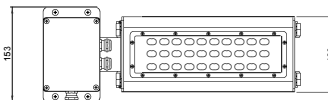

60W (6000lms)

Dimensions

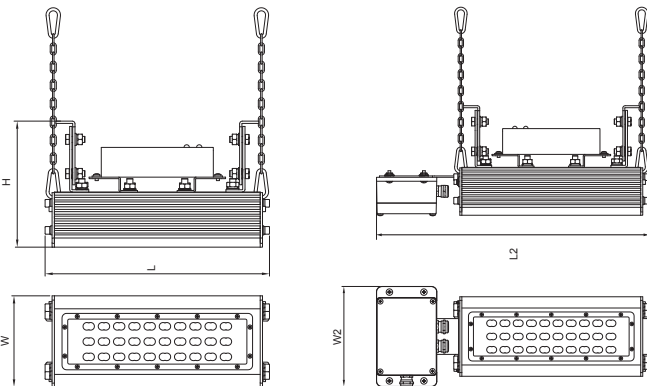

Stand-alone Montaine Rack

Montaine Rack w/ motion sensor

Stand-alone					With motion sensor			
Cat no.	W (mm)	D(mm)	L (mm)	Weight (kg)	Cat no. incl motion sensor	W2 (total width) (mm)	L2 (total length) (mm)	Weight (kg)
R60BLK5K	120	168	294	4	R60BLK5KMS	153	411	4.7
R120BLK5K	120	168	564	6	R120BLK5KMS	153	681	6.6
R180BLK5K	120	168	834	7.6	R180BLK5KMS	153	951	8.3

Catalogue Numbers

Cat no.	Lumen output variant (lm)	Wattage (W)	Efficacy (Llm/cW)	Cat no. Incl. motion sensor
R60BLK5K	6000	60	105	R60BLK5KMS
R120BLK5K	13000	120	110	R120BLK5KMS
R180BLK5K	20000	180	110	R180BLK5KMS