

T8 Batten Range

These luminaires comply with BSEN60598-1 and are suitable for use in normal indoors conditions. Approved normal ambient temperature range: 5°C to 25°C.

Installation notes

- Ballasts comply with BS2818 but the surface temperature of ballast castings may damage standard insulation cables. Where supply cables run adjacent to ballast casings, use cable rated at not less than 150°C (BS6500, type E12) or alternatively protect standard insulation cables with heat resistant sleeving.
- When 20mm conduit bush fixing is used, place an adequately sized steel washer between inside of channel and bush. When small head fixing screws are used fit washers or slip-fix plates.
- 20mm knockouts are provided in channel endplates. For surface conduit end entry fit hexagonal male bush from inside of luminaire channel.
- Mounting in-line. For use with diffusers/controllers space battens at least 15mm apart. For bare battens (or with reflectors) may butt up together.
- On luminaires where gear is mounted on a separate geartray, access to the besa entry and fixing points can be gained by removing the geartray.

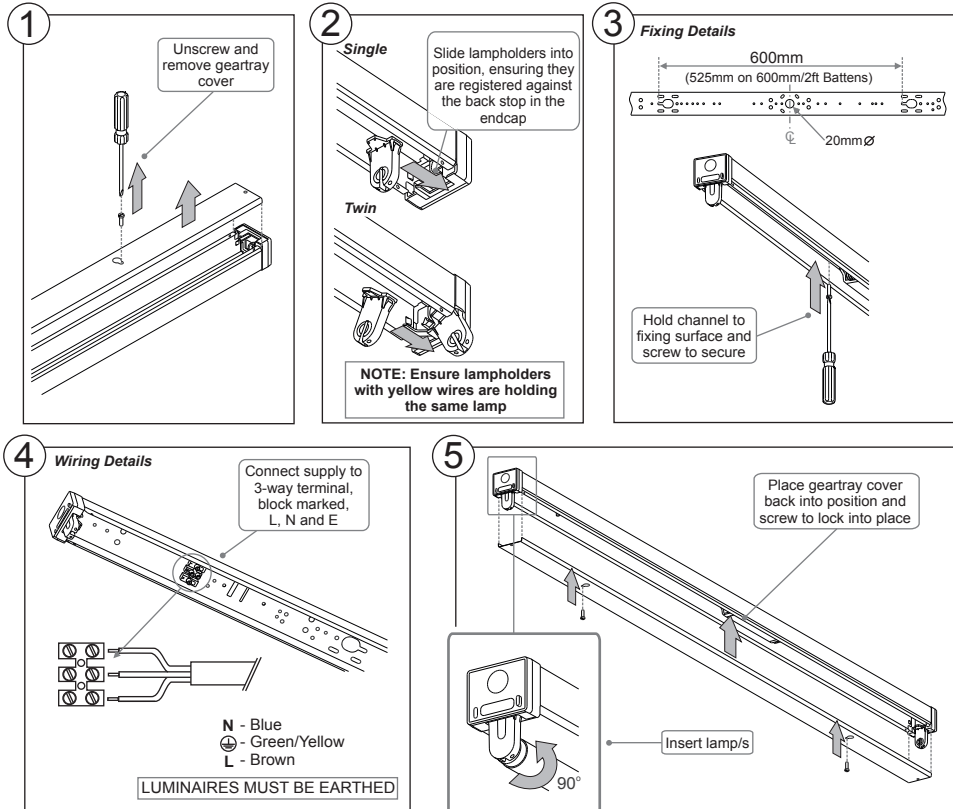

Diffuser/controller attachments

Complete diffuser/controller assembly by firmly pressing home endplates onto diffuser.

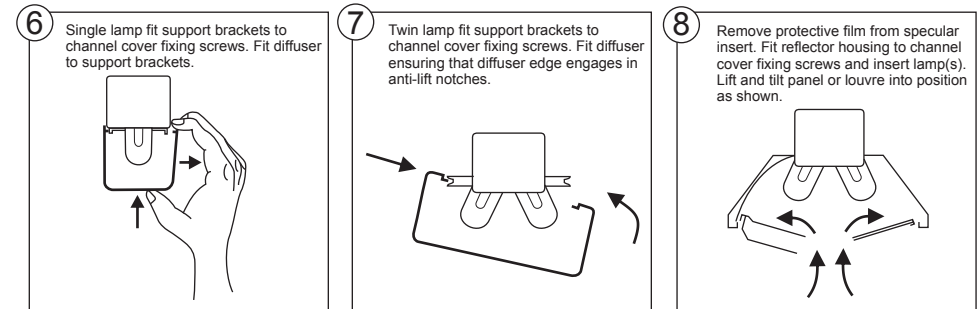

Metal reflector, with wireguard attachments

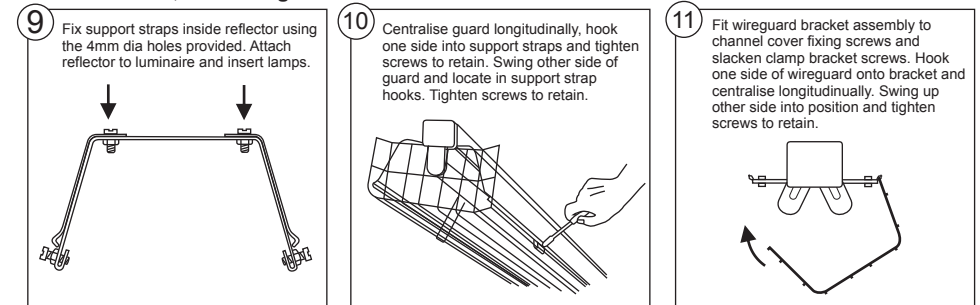

Safe Operation

- Check the rating label for voltage and frequency before connecting this luminaire to the electrical supply.
- Ensure that the supply is switched off when working on this luminaire, whether installing, re-lamping or carrying out any other servicing.
- Use the correct lamps as initially supplied or as indicated on the ballast label.
- This luminaire is suitable for direct mounting on all non-combustible and normally flammable materials, e.g. timber, plasterboard. Do not mount luminaire on or close to readily flammable materials.
- To prevent damage to H.F. Ballasts do not mix H.F. and Conventional Magnetic Ballasts (Switch, Quick or S.R Start) on the same electrical circuit.
- Where use in more onerous situations is required, e.g. In part-completed buildings before "drying-out" is completed, or areas where ambient temperatures are outside the normal temperature range, then consult our Sales Office.

Servicing and Disposal

- At commissioning and handing over of installation ensure that a copy of these instructions are presented to the authority responsible for the operation and maintenance of the luminaire.
- Servicing, e.g. cleaning, lamp replacement, must only be carried out after the electricity supply has been switched off. It must not be assumed that luminaires with lamps not lit are switched off - always check before servicing.
- Cleaning should be carried out at regular intervals to ensure that dirt does not accumulate to an extent that will impair the thermal safety or optical performance of the luminaire is maintained.
- Failed lamps and starter switches must be replaced as soon as practicable by lamps and starters of the same type. For electronic start circuits allow **one minute** for the thermal cut-out to re-set before switching on the mains supply.
- At the end of life the lamp and luminaire are classed as WEEE under directive 2002/96/EC and should be disposed of in accordance with local legislation.

Eaton
Wheatley Hall Road, Doncaster, South Yorkshire, DN2 4NB

Sales	General	International Sales
T: +44 (0)1302 303303	+44 (0)1302 321541	+44 (0)1302 303250
F: +44 (0)1302 367155	+44 (0)1302 303220	+44 (0)1302 303251
E: sales@cooper-ls.com	technical@cooper-ls.com	export@cooper-ls.com