

# Caton

- Product luminaires comply with EN60598 and are suitable for use in normal interior conditions.
- This luminaire has an ambient temperature range of -10°C to 25°C for the non-emergency version
- For Emergency variants - This luminaire has an ambient temperature range of 5°C to 25°C, to ensure the batteries work correctly

**1**

### Fitting into Ceiling

**Lay-in**

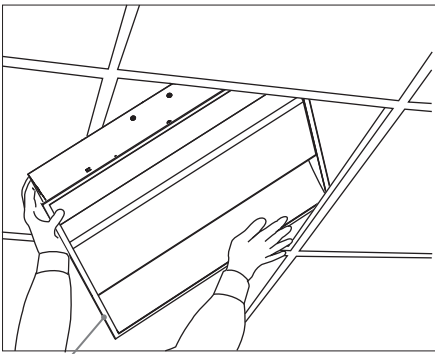

Support fitting by the steel outer frame whilst lifting and tilting into position. Keep hands off plastic extrusion.

Void required from front of 'T' bar is 300mm

**Draw up**

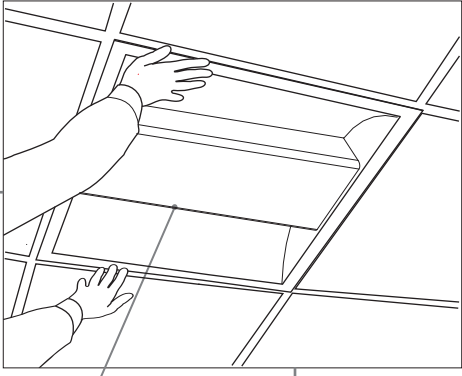

CTNBK bearers (ordered separately) are installed via adjacent ceiling tiles. It is recommended that two people perform the install. Support luminaire by the steel outer frame whilst lifting luminaire into ceiling. Keep hands off plastic extrusion.

Please Note: This fitting is not suitable for solid ceilings

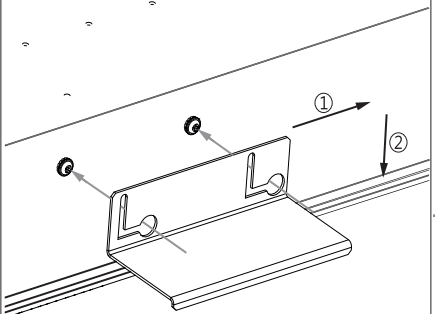

Slide bracket over screws and lockwashers (ensure lockwasher is on front face of bracket) slide to the right then down until bracket touches top of ceiling 'T'. Tighten screws to **0.8Nm (IMPORTANT)**. Repeat for other bracket on opposite side.

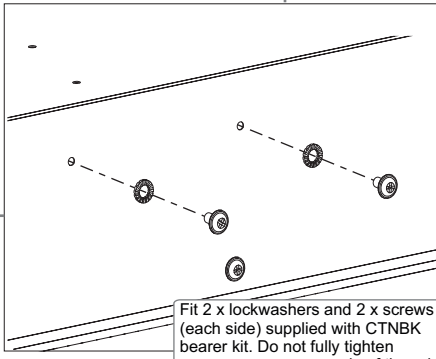

Fit 2 x lockwashers and 2 x screws (each side) supplied with CTNBK bearer kit. Do not fully tighten screws, engage a couple of threads. Repeat for opposite side.

**2**

### Connecting to mains:

- Connect mains supply cable to plug supplied (as shown below)
- Connect plug to socket from luminaire
- Ensure mains supply is switched off

**Mains (3-pole connector)**

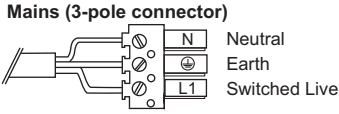

**Mains/Emergency (4-pole connector)**

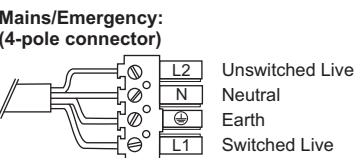

**Mains/Emergency with Dimming/Sensor: (6-pole connector)**

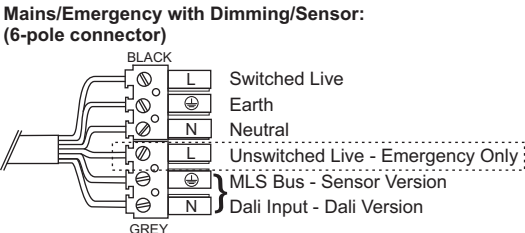

**ENSURE COVERS ARE USED WITH CONNECTORS**

**LUMINAIRES MUST BE EARTHED**

**MUST NOT BE HIGH VOLTAGE OR MEGGER TESTED**

**BATTERY IS PRE-CONNECTED ON EMERGENCY LUMINAIRES. TO MAINTAIN BATTERY CAPACITY LUMINAIRE MUST BE INSTALLED AND POWERED WITHIN 6 MONTHS OF DATE ON LUMINAIRE PACK LABEL**

### Safe Operation

1. Check the rating label for voltage and frequency before connecting this luminaire to the electrical supply.
2. Ensure that the mains supply is switched off when working on this luminaire, whether installing or carrying out any other servicing.
3. Do not mount luminaire on or close to readily flammable materials.
4. To prevent damage to driver, do not mix with conventional magnetic ballasts on the same electrical circuit.
5. Where use in more onerous situations is required, e.g. In part-completed buildings before "drying-out" is completed, or areas where ambient temperatures are outside the normal temperature range, then consult our Sales Office.
6. The light source contained in this luminaire shall only be replaced by the manufacturer or his service agent or a similar qualified person.
7. **DO NOT** alter dip switch settings

### Servicing and Disposal

1. At commissioning and handing over of installation ensure that a copy of these instructions is presented to the authority responsible for the operation and maintenance of the luminaires.
2. Servicing, e.g. cleaning, must only be carried out after the electricity supply has been switched off. It must not be assumed that luminaires with light sources not lit are switched off-always check before servicing.
3. Cleaning should be carried out at regular intervals to ensure that dirt does not accumulate to an extent that will impair the thermal safety or optical performance of the luminaire. Regular cleaning will also ensure that the optical performance of the luminaires is maintained. Do not use any abrasive materials/substances to clean the extruded diffuser. A simple wipe with a soft lint-free cloth will suffice.
4. Avoid touching the LED array surface. To clean - Blow surface with either dry air or nitrogen gas.
5. At the end of life the luminaire is classed as WEEE under directive 2002/96/EC and should be disposed of in accordance with local legislation.

### Luminaire Cleaning

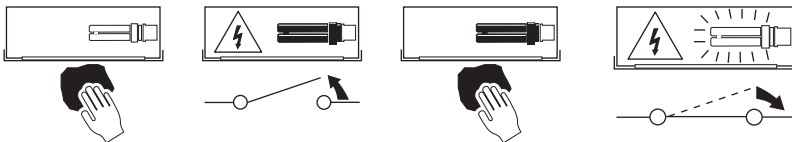

### End of Life and Components Disposal

