

# CEAG VLL Series

## LED Linear fixtures



*Powering Business Worldwide*

## 1. Dimensions

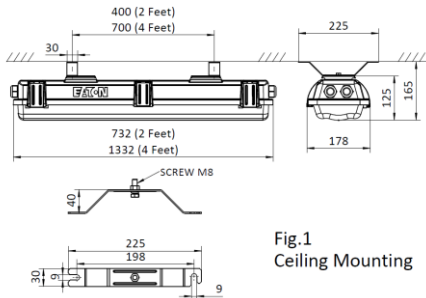

Fig.1 Ceiling Mounting

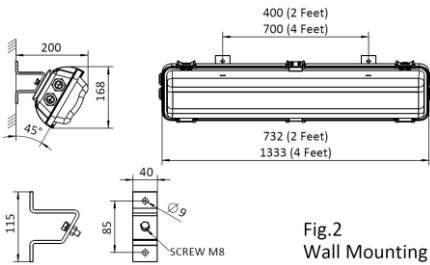

Fig.2 Wall Mounting

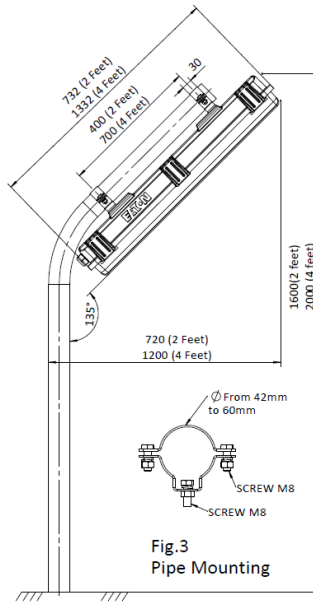

Fig.3 Pipe Mounting

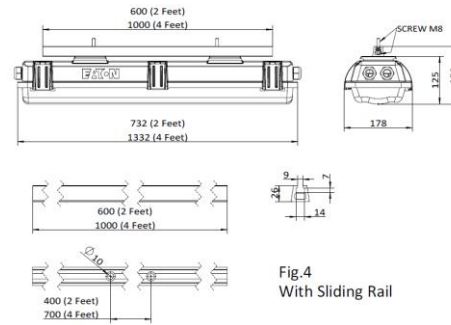

Fig.4 With Sliding Rail

## 2. Technical data

Hazardous area specification	
Type of protection:	Ex d e i b mb Dust protected enclosure
IEC Certification Marking:	Ex db eb mb IIC T6...T5 Gb Ex eb mb IIC T6...T5 Gb Ex tb IIIC T80°C...T80°C Db
ATEX Certification Marking:	II 2 G Ex db eb mb IIC T6...T5 Gb II 2 D Ex tb IIIC T80°C Db
Ambient temperature:	-25°C~+40°C/50 °C ; -40°C~+40 °C/55°C
Temperature class:	T6...T5
IECEx Certificate No.:	IECEx NEP 21.0020X
EC type examination Certificate No.:	SEV 22 ATEX 0584 X
Degree of protection:	IP 66 acc. to EN60529/IEC60529
Approval of the production Quality assurance:	Fimko ATEX 5952
Enclosure specification	
Material of enclosure:	Glass Fiber Reinforced Plastic (GRP)
Finish:	Surface texture treatment
Material of cover:	Polycarbonate (PC)
Mounting bracket:	Stainless steel or Steel painted
Fasteners:	All external fasteners stainless steel
Installation:	Mounting bracket or Screw fixed
Weight:	Refer to Type Configuration.
Entry specification	
Indirect entry:	M20 or M25 X 1.5 cable entry.
Electrical specification	
Wattage:	25W/50W/58W; 29W/57W/63W(EM)
Voltage:	100-240Vac 50/60Hz, 108 - 250Vdc
Power factor:	≥0.9
Anti surge voltage:	L-N 4KV;L/N-PE 4KV
Maximum over-line current:	16A
Storage temperature:	-25°C~60°C
Lamp:	LED Arrays
CRI:	70/80
Insulation class:	I acc. to IEC60598
Terminals capacity:	2.5mm <sup>2</sup> Terminal/6mm <sup>2</sup> Terminal Solid: 0.5~6mm <sup>2</sup> , Flexible: 0.25~4mm <sup>2</sup>

## 6. Cable gland recommend

Entry size	Part No.	Cable size	Torque (Nm)	
			screw-in enclosure	For cable
M20	CAP816609	8.5-16	20	20
M25	CAP816709	12-21	30	30

Note: Mounting the selected cable glands acc. type and dimensions of the main connection cable. Following their manufacturer instructions.

## 3. Safety Instructions

**This product should be installed, inspected, and maintained by a qualified electrician only, in accordance with national regulation, including the relevant standard and, where applicable, in acc. With IEC 60079-17 on electrical apparatus for explosive atmospheres.**

**The national safety rules and regulations for prevention of accidents and the following safety instructions in these operating instructions, will have to be observed!**

- ❖ **The luminaire must not be operated in Zone0 and in Zone 20!**
- ❖ **When using in Zone 21, Zone 22, the requirements of IEC/EN 60079-14 relating to temperature must be observed. The indicated surface temperatures are not related to a layers above 5 mm thickness.**
- ❖ **Do not install where the marked operating temperature exceed the ignition temperature of the hazardous atmosphere.**
- ❖ **Do not operate in ambient temperatures above those indicated on the luminaire nameplate.**
- ❖ **The luminaires shall be operated as intended and only in undamaged and perfect conditions! And Keep tightly closed when in operation!**
- ❖ **The technical data indicated on the luminaire are to be observed!**
- ❖ **Change of the design and modifications to the luminaire are not permitted!**
- ❖ **Multiple, short-term switching must be observed!**
- ❖ **Only genuine Eaton Crouse-Hinds spare parts may be used for replacement!**
- ❖ **Repairs that affect the explosion protection, may only be carried out by Eaton Crouse-Hinds or qualified electrician!**
- ❖ **Potential electrostatic risk clean only with a damp cloth**
- ❖ **Do not open when an explosive atmosphere is present**
- ❖ **Potential electrostatic charging hazard see instructions.**
- ❖ **Do not transport through a hazardous area.**

## 4. Conformity with standards

This explosion protection linear lighting meet the requirements of IEC/EN 60079-0, IEC/EN 60079-1, IEC/EN 60079-7, IEC 60079-11, IEC 60079-18, IEC/EN 60079-31. It also complies with the EC Directives for "Apparatus and protective system for use in explosion atmospheres" (2014/34/EU). It has been designed, manufactured and tested in accordance to the state of the art and according to ISO 9001:2008. The luminaires are suitable for use in explosive atmospheres, Zone1, Zone2 according to IEC60079-10-1 and dust area Zone21 and Zone22 according to IEC60079-10-2. Proper separately certified plastic cable glands or plastic plugs or plastic breather complying with IEC 60079-0, IEC 60079-7, IEC 60079-31 should be applied during the installation.

## 5. Fields of Application

The Luminaire with Ex d e m protection and IP66 sealing making it suitable for use for potentially explosive atmospheres including ignitable gas and dust applications. The luminaire is designed for use in Zone1/Zone21 and Zone2/Zone22 hazardous areas in indoors and outdoors in Marine and Wet locations, where moisture, dirt, corrosion, vibration and rough usage may be present. Application ambient temperature is -25 °C ~+40/+50 °C or -40°C~+40/+55 °C . Refer to the luminaire nameplate, For specific information, corresponding operating temperature(T-Code). The enclosure materials used, including any external metal parts, are High quality materials that ensure a corrosion resistance and resistance to chemical substances according to the requirements for use in a "normal" industrial atmosphere. In case of use in an extremely aggressive atmospheres, please refer to manufacture.

## 7. Type configuration and Max. Ambient and Temperature Ratings

Std. Cat No.	Color Temp.	System power	T Class (Gas)	T °C (Dust)	Voltage (V)	Rated current (mA @230Vac)	Lm * (5700K)	Weight (Kg)
VLL-3L-***	5700K	24W	T5...T6	80	100-240Vac, 50-60Hz 108-250Vdc	111 mA	3115 lm	4.3
VLL-5L-***		50W				230 mA	6465 lm	7.5
VLL-7L-***		57W				259 mA	7429 lm	7.5

\* Tolerance +/-10%

## 8. Installation

### 8.1 General

The respective national regulations IEC/EN 60079-14 as well as the general rules of engineering which apply to the installation and operation of explosion protected apparatus will have to be observed!  
The improper installation and operation may result in the explosion protection and invalidation of the guarantee.

### 8.2 Mounting luminaire

#### 8.2.1 Mounting the bracket

Only use the accompanying mounting bracket! Securely fasten the mounting bracket to a suitable base with sufficient load-bearing capacity. The mounting should be secured with M8 bolts and relative lock washers and nuts should be used.

*The minimum distance between the luminaire and illuminated surface, directly in front of the luminaire, is 0.5 meter. The lighting must not be illuminated when at a distance of less than 0.5m from inflammable material*

### 8.3 Cable entries/Plugs and Breathing valve

The "Increased safety (Exe)" properties must be preserved when select and mount cable entry/plug and breathing valve. Unused holes must be closed with certified plug to establish the Exe protection category. The cable glands/plugs and breathing valve should be Ex tb certified if the whole product is Ex tb certified also. **Cable entries sealing washer(if required by manual of cable gland/plug) must be used to obtain IP66.**  
The authoritative mounting guidelines for the cable glands and breathing valve used must be observed. Mounting the selected cable entries acc. type and dimensions of the main connection cable following their manufacturer instructions. The cable temperatures are given as the rise over the max. rated ambient (Tamb). This allows the user to adjust the cable specification for actual maximum site ambient. Only heat resistant cable according to the data on the type label may be used! The max. conductor size is 6mm<sup>2</sup>. The standard looping cable size is 4mm<sup>2</sup>.

### 8.4 Opening/closing the luminaire

#### 8.4.1 General

*The opening of luminaire always shall be without voltage! All gasket seals must be clean and undamaged;*

*before closing the luminaire. Make sure the luminaires is well closed before operation!*

#### 8.4.2 Exe chamber cover

Open the buckles and remove the PC cover. And carry out the steps in reverse order to close the luminaire. Check all buckles to ensure a secure fit during operation.(Illustration 4 )

### 8.5 Electrical connection

*The electrical connection of the luminaire must only be established by qualified electricians. Make sure the supply voltage is the same as the luminaire voltage! Use proper supply wiring as specified on the nameplate of the luminaire and in this instructions! Excessive tightening may affect or damage the connection.*

#### 8.5.1 Wire connection

The conductors shall be connected with special care in order to maintain the explosion category. The conductor itself shall not be damaged. The connectible min. and max. conductor cross-sections shall be observed (see technical data). All terminals, used and unused, shall be fully tightened to prevent incorrect selection between 1.2Nm for Exe T6P and 0.6~0.8Nm for MK3/2/E. Main connection: See wiring diagram. Remove the single core cable which shorts the terminals of MK3/2/E when install the inhibit switch. Type of connected conductors: Rigid with cable lug, flexible with ferrule, pin cable lug or cable lug.

## 9. Putting into operation

Prior to putting the apparatus into operation, the tests specified in the relevant national regulations shall be carried out. Insulation measurements may only be carried out between PE and the external conductor L1 (L2, L3) as well as between PE and N.

- Measurement voltage: Max. 1.5 KV AC

- Measurement current: Max.5 mA

- The luminaire may only be operated when closed.

- It is generally recommended (see IEC/EN 60079-14) that you ensure the type of protection of the construction is not impaired during installation.

## 10. Maintenance/Serviceing

### 10.1 General

The relevant national regulations which apply to the maintenance/servicing of electrical apparatus in explosive atmospheres, shall be observed (EN/IEC 60079-17). The interval between maintenance depends upon the ambient conditions and the hours of operation. The recommendations given within EN/IEC 60079-17 for recurring checks must be observed.

### 10.2 Checks

*The equipment must be de-energised before opening* Visual inspection should be carried out at a minimum of 12 monthly intervals and more frequently if conditions are severe, refer to EN/IEC 60079-17. The time between luminaire changes could be very infrequent and this is too long a period without inspection.

## 10.3 Routine Examination

During maintenance, the parts affecting the level

of protection must be checked in particular:

- Ensure the luminaire is lit when energised and examine the enclosure and glass for any signs of cracks and damage.
  - When de-energised and left to cool, there should be no significant sign of internal moisture. If there are signs of water ingress, the luminaire should be opened up, dried out, and any likely ingress points eliminated by re-gasketing, re-greasing or other replacement.
  - Check the gasket of pc cover and LED housing for any damage or permanent set and replace as required.
  - Terminal, screw glands and blanking plugs for secure fitting.
  - To maintain the light output, clean the protective pc cover periodically with a damp cloth or a mild cleaning fluid.
- If this product is used in the combustible dust area, outside of enclosure must be cleaned on a regular basis to prevent accumulation of dust.
- The cable connections should be checked for tightness. The gasket should be checked for cracks or lack of elasticity, and if necessary, replaced.
  - Check that mountings are secure and the adjusting bolts are tight.
  - If it has been suspected that the luminaire has mechanical damage, a stringent workshop overhaul will be required. Where spares are needed, these must be replaced with factory specified parts.
- No modifications should be made without the knowledge and approval of the manufacturer.
- Cleaning the joint of housing assy. and pc cover use a damp cloth or a mild cleaning fluid.*

## 11. Repair/Overhaul/Modifications

### 11.1 General

*The national regulations EN/IEC60079-19 have to be observed! Repairs and overhaul may only be carried out with genuine Eaton Crouse-Hinds spare parts. In the case of battery failure, the battery pack must be replaced as a complete unit from the manufacture.*

*Replacement of the battery can be done only by the manufacturer staff or the persons on behalf of the manufacturer.*

*Only use original spare parts. If the luminaire was previously in operation then wait to cool enough before opening. Repairs that affect the explosion protection, may only be carried out by Eaton Crouse-Hinds or a qualified electrician in compliance with the applicable national rules. Modifications to the device or changes to its design are not permitted. After carrying out repair or overhaul work, ensure that the "Exde" properties have not been affected. Assistance may also be obtained through Cooper Electronic Technologies (Shanghai) Co., Ltd. Sales Service department, 955 ShengLi Road, Pudong Shanghai 201201 Phone (86) 21-28993943*

## 12. Disposal/Recycling

When the apparatus is disposed of, the respective national regulations on waste disposal will have to be observed.

**Wiring diagram 1:** 2 feet or 4 feet normal version

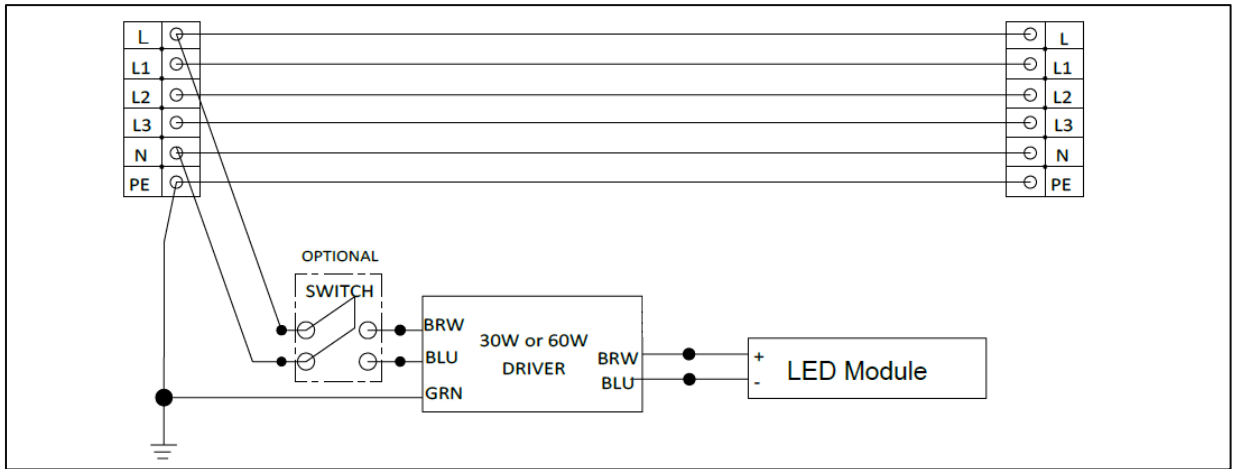

**Wiring diagram 3:** Inhibit switch light fitting External connection

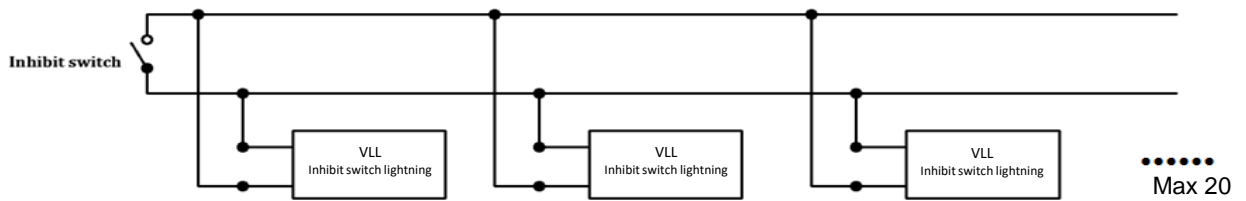
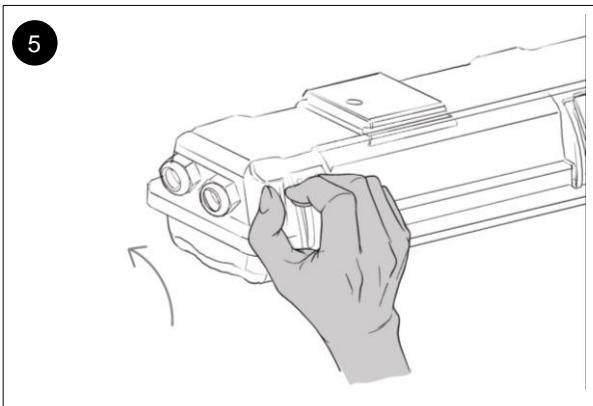
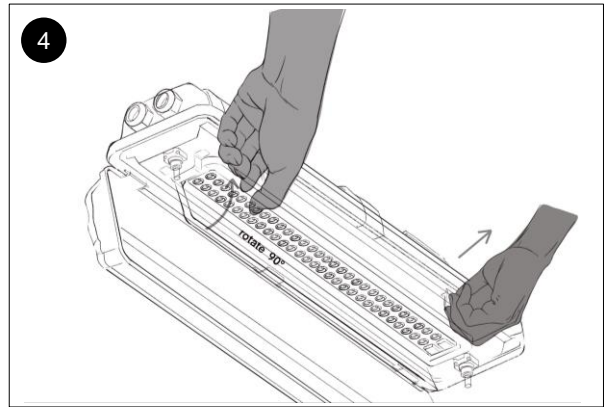
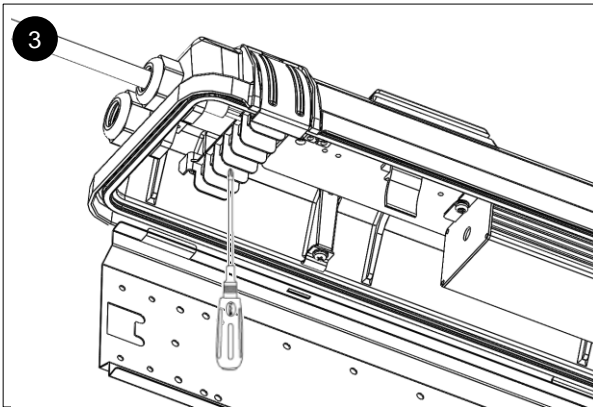
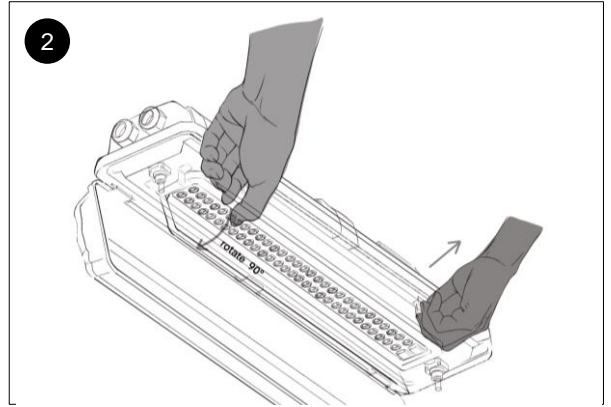
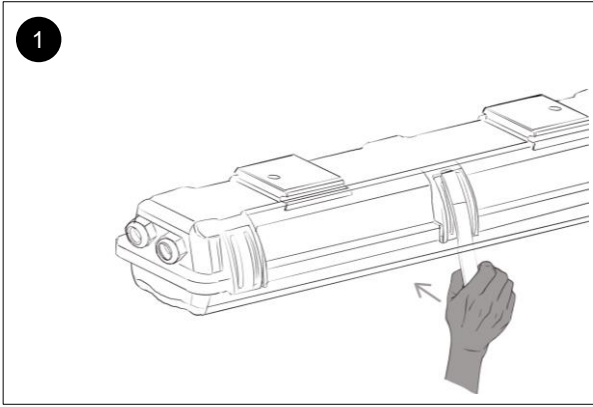

Illustration 4:



Eaton's Crouse-Hinds Division Cooper Electric (Changzhou) Co., Ltd. No.189 Liuyanghe Road, Xinbei District, Changzhou, Jiangsu, China

© 2020 Eaton  
All Rights Reserved  
Printed in China  
Publication No. IM 0535

Eaton is a registered trademark.

All trademarks are property of their respective owners.



Powering Business Worldwide