

Champ® Pro PVMA industrial LED lighting fixtures



WIRING DIAGRAMS

Installation & maintenance information

IM0454

SAVE THESE INSTRUCTIONS FOR FUTURE REFERENCE

APPLICATION

PVMA luminaires are suitable for use in the following areas as defined by Underwriters Laboratories (UL), the International Electrotechnical Commission (IEC) and European Conformity (CE).

Refer to the luminaire nameplate for specific maximum ambient temperature suitability.

PVMA:

UL standards

- UL1598 Luminaires, UL1598A Marine

IEC standards

- IEC 60598
- IP66

European conformity

- CE

Luminaire construction is designed for use indoors and outdoors in marine and wet locations, where moisture, dirt, corrosion, vibration and rough usage may be present.

PVMA supplied with a choice of voltage:

UL: 120-277 VAC 50/60 Hz
347-480 VAC 50/60 Hz
127-300 VDC

CE: 120-240 VAC 50/60 Hz
127-250 VDC

⚠ WARNING

To avoid the risk of fire or electric shock, this product should be installed, inspected and maintained by a qualified electrician only, in accordance with all applicable electrical codes.

⚠ WARNING

To avoid electric shock:

Be certain electrical power is OFF before and during installation and maintenance.

Luminaire must be supplied by a wiring system with an equipment grounding conductor.

To avoid burning hands:

Make sure lens and housing are cool when performing maintenance.

To avoid product degradation:

Make sure the supply voltage is the same as the luminaire voltage.

Do not operate in ambient temperatures above those indicated on the luminaire nameplate.

Use proper supply wiring as specified on the luminaire nameplate.

All gasket seals must be clean.

Keep tightly closed when in operation.

WIRING

1. Pull field wiring into cover module.
2. Close all unused conduit entries with conduit plugs provided. To prevent galling and to ensure water-tightness, lubricate conduit plugs with Eaton's Crouse-Hinds series HTL lubricant before installing, and secure wrench-tight with at least five (5) full threads engaged (42-52 ft.-lb. for 3/4" plugs, and 58-68 ft.-lb. for 1" plugs).
3. Hang LED luminaire on the cover module hinge hook. See Figure 2a.
4. Connect supply wires to luminaire wire leads or terminal block per the attached wiring diagrams using methods that comply with all applicable codes. See Figure 2b. Tighten all electrical connections.
5. Close driver housing onto cover module, making sure that all wires are safely inside driver housing. Tighten captive closing screw to 30 in.-lbs. (3.4 N-m). Ensure two (2) bosses on driver housing are in contact with cover module.
6. Turn power on.



FIGURE 2a

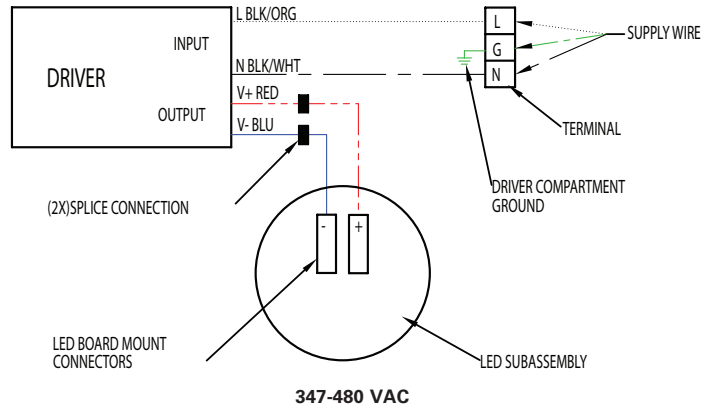
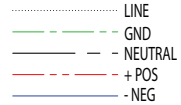
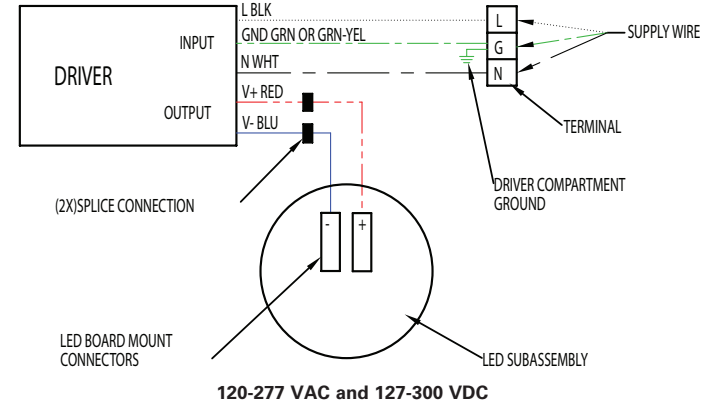
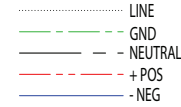
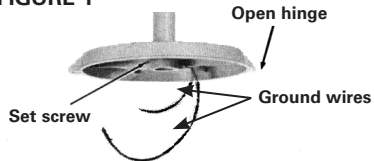

FIGURE 2b

FIGURE 1



WIRE GUARD INSTALLATION

Loosen but DO NOT completely remove wire guard screw. If already loosened, move to next step.

Set wire guard in place by pushing it over the bottom rim of the fixture which is on the lowest casting until it sits in place above that rim. Ensure that the wire guard is in place around the complete bottom and is not partially in place above the rim.

Tighten the screw attached to wire guard until guard is securely attached to bottom casting. The screw will be tight enough when the wire guard can no longer easily rotate on the fixture.

NOTE: The sheet metal tabs which the screw goes through do not need to be touching for the guard to be securely fastened; the wire guard will be secure without those two tabs touching one another.

FIELD ASSEMBLED FIXTURES PVMA industrial LED lighting fixtures

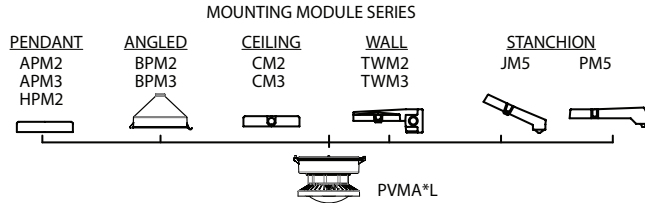

MOUNTING MODULE NOTES:

- 2: indicates 3/4" NPT thread
- 3: indicates 1" NPT thread
- 5: indicates 1-1/2" thread
- Pendant, angled, ceiling and stanchion mounts have one (1) conduit entry; ceiling and wall mounts have five (5) conduit entries

MAINTENANCE

1. Perform visual, electrical and mechanical inspections on a regular basis. The environment and frequency of use should determine this. However, it is recommended that checks be made at least once a year. We recommend an Electrical Preventive Maintenance Program as described in the National Fire Protection Association Bulletin NFPA No. 70B: Recommended Practice For Electrical Equipment Maintenance (www.nfpa.org).
2. The lens should be cleaned periodically to ensure continued lighting performance. To clean, wipe the lens with a clean, damp cloth. If this is not sufficient, use a mild soap or a liquid cleaner such as Collinite NCF or Duco #7. Do not use an abrasive, strong alkaline or acid cleaner. Damage may result.
3. Visually check for undue heating evidenced by discoloration of wires or other components, damaged parts or leakage evidenced by water or corrosion in the interior. Replace all worn, damaged or malfunctioning components, and clean gasket seals before putting the luminaire back into service.
4. Electrically check to make sure that all connections are clean and tight.
5. Mechanically check that all parts are properly assembled.
6. If the lens is removed from the fixture, the lens gasket must be replaced to maintain restricted breathing ratings.

REPLACEMENT PARTS

Eaton's Crouse-Hinds series PVMA lighting fixtures are designed to provide years of reliable lighting performance. However, should the need for replacement parts arise, they are available through your authorized Crouse-Hinds distributor. Assistance may also be obtained through your local Crouse-Hinds representative.

Crouse-Hinds Sales Service Department, 1201 Wolf Street, Syracuse, New York 13208, Phone (866) 764-5454.

⚠ WARNING

To avoid electric shock:

Be certain electrical power is OFF before and during installation and maintenance. Luminaire must be supplied by a wiring system with an equipment grounding conductor.

To avoid burning hands:

Make sure globe or refractor and lamp are cool when performing maintenance.

INSTALLATION CHECKLIST

1. Verify sufficient HTL lubricant is on conduit plugs (recommend approximately 1/8" bead around the first thread of plug) and that all unused conduit entries on the cover module are closed with lubricated plugs.



2. Verify conduit plugs are installed to at least five (5) full threads into the cover module conduit entries.



3. Verify installed conduit plugs are torqued to 42-52 ft.-lbs. for 3/4" plugs and 58-68 ft.-lbs. for 1" plugs. Make sure at least five (5) full threads are engaged.

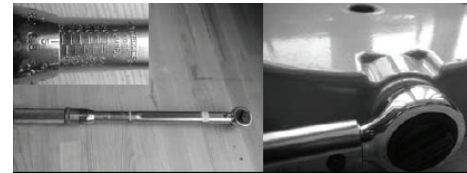

4. Verify supply wires are connected to luminaire wire leads (or terminal block) per wiring diagrams. Tighten screws with a force of 7 in.-lbs. torque.

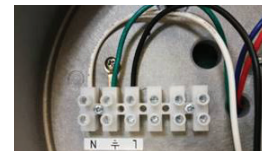

5. Verify all electrical connections are tightened.



6. Verify all wires are safely and neatly inside driver housing and not on top of wire terminal. Close driver housing onto cover module.



7. Verify captive closing screw is tightened to 30 in.-lbs. (3.4 N-m) and two (2) bosses on driver housing are in contact with cover module.



All statements, technical information and recommendations contained herein are based on information and tests we believe to be reliable. The accuracy or completeness thereof are not guaranteed. In accordance with Eaton's Crouse-Hinds Division's "Terms and Conditions of Sale," and since conditions of use are outside our control, the purchaser should determine the suitability of the product for his intended use and assumes all risk and liability whatsoever in connection therewith.

EATON CROUSE-HINDS
SERIES

Eaton's Crouse-Hinds Division
Cooper Electric (Changzhou) Co., Ltd
No.189 Liuyanghe Road, Xinbei District
Changzhou, Jiangsu, China
Copyright © 2018

IM0454
Revision 1
New 10/18