

NHID/CRANE BOOM MOUNT, GOLIATH SERIES

HID LUMINAIRES

Installation & Maintenance Information

SAVE THESE INSTRUCTIONS FOR FUTURE REFERENCE

CAUTION Read carefully before installing and wiring the luminaire.

These instructions include information for installation in both hazardous and marine locations. Any warning or special instructions should be closely followed. Marine installations on boats should be done in accordance with the regulations of the USCG, CFR46, SUB CHAPTER J, PARTS 110-113. Hazardous area installations should be done in accordance with article 500 and 501 of the NEC. Check the ratings to insure suitability for the area.

INSTALLATION & ELECTRICAL WIRING

WARNING Risk of electrical shock hazard, only qualified personnel should conduct this procedure! Do not make electrical connections with the power ON. Disconnect supply circuit at least 30 minutes before opening fixture for servicing and/or re-lamping. Refer to fixture nameplate for minimum supply wire rating.

1. Define mounting position of crane boom mount (6D). See mounting dimensions illustration below. If needed cut 1-7/8" diameter pipe to desired length. Mount and/or weld crane boom mount in place. Assemble fixture to crane boom mount using 1/2" bolts and washers (9J, qty 3x) with nuts (9H, qty 3x) provided.

2. Attach threaded fitting to the 3/4" NPT coupling.

Fitting must be sufficiently tightened to produce a vapor-tight seal.

3. Unlatch all eight (8) lens frame latches (5A) and open the lens frame. Avoid damaging the sealing gasket during installation and/or servicing.

4. Remove screws (9C, qty 2x) and remove main reflector (3B).

5. Remove screws (9D, qty 3x) and remove lower reflector (3A).

6. Route supply cable thru fitting.

7. Strip the supply cable(s) jacket (not provided) back approximately 4".

8. Strip the insulation of the supply wires back approximately 3/8".

WARNING See nameplate for voltage & frequency requirements!

Fixtures may be provided with multi-voltage ballast (120/208/240/277 vac 60Hz. Unless otherwise specified at time of order, fixtures are pre-wired for 120 vac. To change the voltage, remove the wire nut from the desired voltage lead. Make sure unused voltage leads ends are capped with wire nuts.

9. Connect L1 or hot lead to the desired voltage. Connect L2 or neutral to the ballast common yellow wire or white lead. Connect ground wire to green ground wire (8E). See wiring diagram illustration below.

10. Pull excess supply wire out of housing.

WARNING Verify that the H.I.D. lamp complies with lamp specifications on fixture nameplate.

11. Install the proper wattage lamp (not provided) into the lampholder (4A), making sure the center contact of the lamp seats well into the lampholder.

If a lamp support is supplied, position the lamp in the support for maximum retention.

12. Replace reflectors (3B) and (3A) using screws (9C) and (9D).

13. Close lens frame and securely engage all eight (8) lens frame latches (5A).

WARNING Product must be used only with lens intact and all lens frame latches fully engaged. Replace cracked or damaged lens prior to use.

14. Aim the fixture. Loosen the two bolts (9I) holding the 'U'-shaped bracket to the housing. Rotate the fixture to the desired direction and securely tighten the 'U' bracket bolts (9I).

WARNING If aiming position must be readjusted, use caution, as external surfaces may become extremely hot.

15. Grease crane boom thru 1/8" grease insert (5D).

COMPONENT TRAY REPLACEMENT

1. Unlatch all eight (8) lens frame latches (5A) and open lens frame.

2. Remove lamp.

3. Remove screws (9C, qty 2x) and remove main reflector (3B).

4. Remove screws (9D, qty 3x) and remove lower reflector (3A).

5. Disconnect supply wires. Disconnect ground wire.

6. Remove nuts (9E) (qty 4, 1/4-20) from bottom of housing.

Do not remove center nuts (9G).

7. Pull tray (4F) up and out of housing.

8. To install component tray (4F) perform these steps in reverse order.

Spare Parts	
Description	Part Number
Lens	INX2153
HPS Lampholder	INX4004
MV & MH Lampholder	INX4100
Crane Boom Mount	INX7001

Must be installed in accordance with the NEC (National Electrical Code) and all other applicable codes. All luminaires must be properly grounded. To reduce the risk of fire or explosion, do not install where the marked operating temperature exceeds the ignition temperature of the hazardous atmosphere. Disconnect the fixture from the supply circuit before opening. Keep tightly closed when in operation. Do not attempt to install this luminaire unless you are familiar with warnings, cautions and procedures outlined in this information sheet.

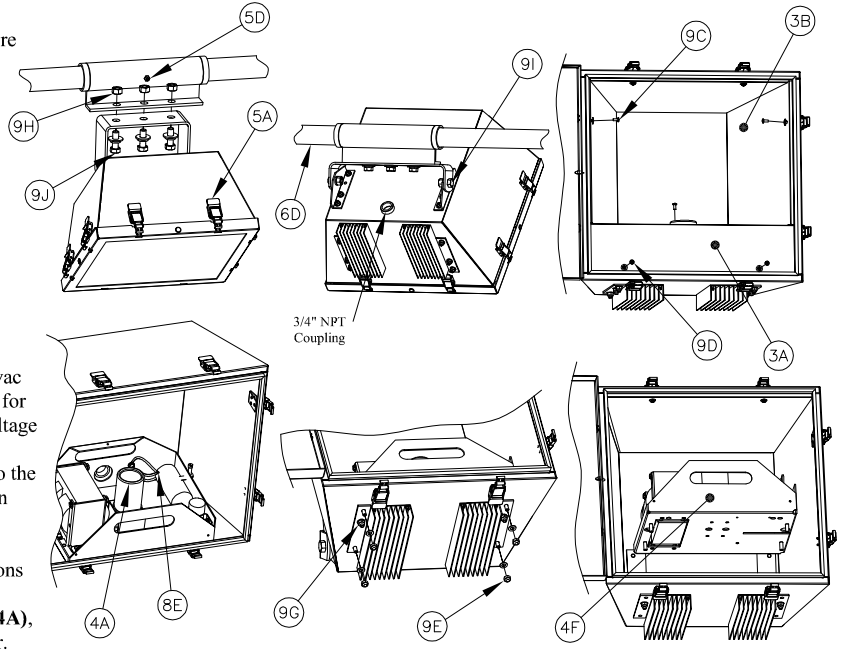

HIGH PRESSURE SODIUM & PULSE START METAL HALIDE

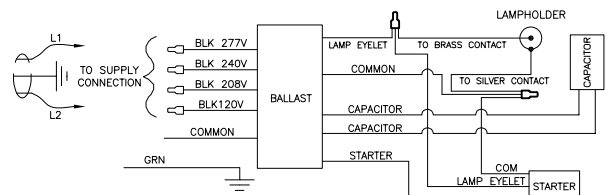

MERCURY VAPOR & METAL HALIDE

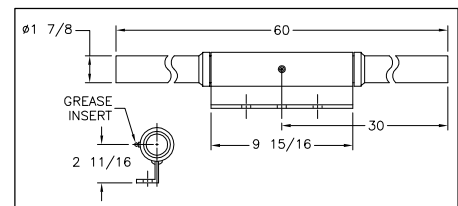
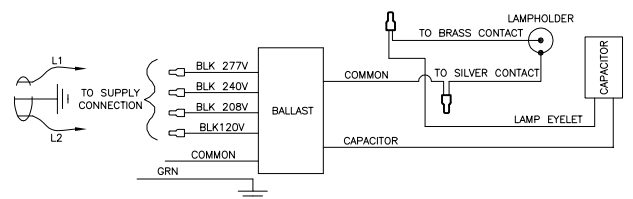

Crane Boom Mount Dimensions

All statements, technical information and recommendations contained herein are based on information and tests we believe to be reliable. The accuracy or completeness thereof are not guaranteed. In accordance with Crouse-Hinds "Terms and Conditions of Sale", and since conditions of use are outside our control, the purchaser should determine the suitability of the product for his intended use and assumes all risk and liability whatsoever in connection therewith.