

# SURFACE MOUNT BRACKET, STAINLESS STEEL

## Installation Information

**SAVE THESE INSTRUCTIONS FOR FUTURE REFERENCE**

**⚠ CAUTION** Read carefully before installing mounting bracket.

These instructions only include information for installation of mounting bracket. Before installing mounting bracket read fixture installation and maintenance instructions included with fixture.

**⚠ WARNING** Risk of electrical shock hazard, only qualified personnel should conduct this procedure! Disconnect supply circuit before installing luminaire to mounting bracket.

1. Mount surface mount bracket (6D) using four 1/2" diameter bolts (not provided) per mounting dimensions illustration below. Select proper anchor and surface to support fixture weight.
2. Assemble the 'U' bracket (6C) to surface mount bracket using 1/2" bolts and washers (9J, qty 3x) provided.

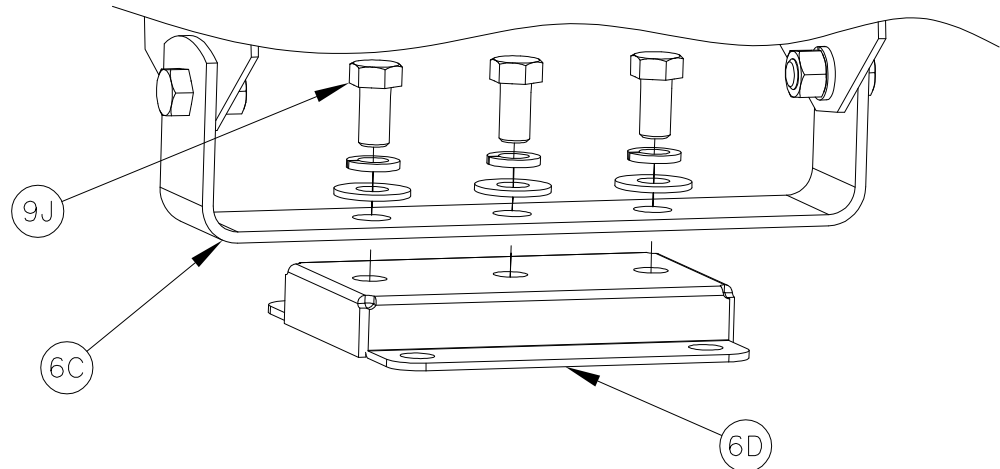

3. Aim the fixture. Loosen the two bolts (9I) holding the 'U' bracket (6C) to the fixture. Rotate the fixture to the desired direction and securely tighten the 'U' bracket bolts (9I).

**⚠ WARNING** If aiming position must be readjusted, use caution, as external surfaces may become extremely hot.

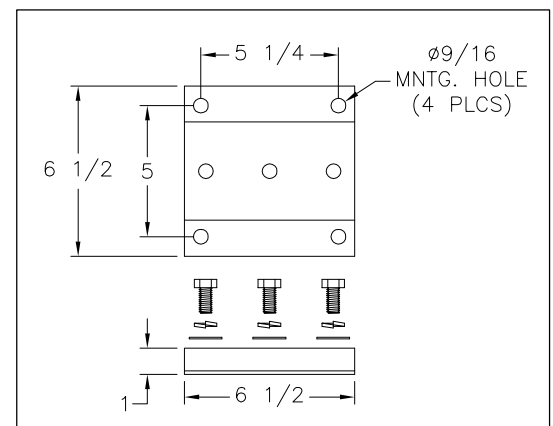
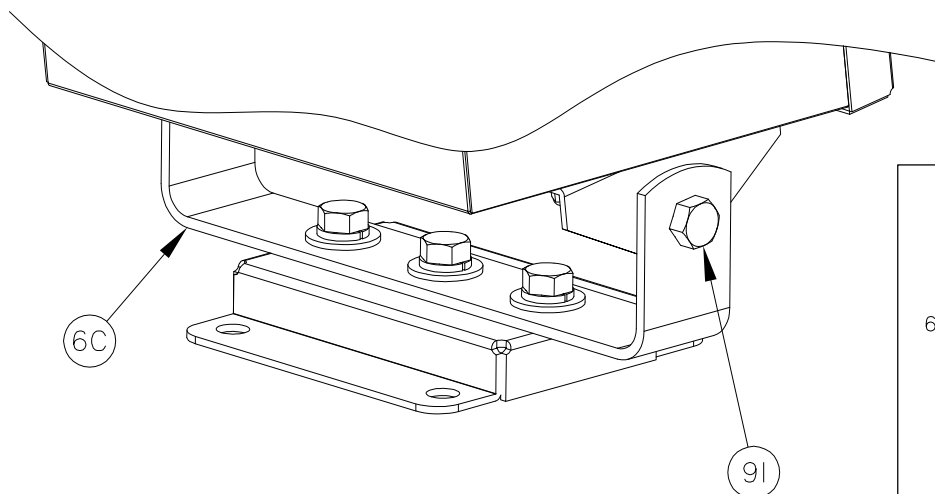

All statements, technical information and recommendations contained herein are based on information and tests we believe to be reliable. The accuracy or completeness thereof are not guaranteed. In accordance with Crouse-Hinds "Terms and Conditions of Sale", and since conditions of use are outside our control, the purchaser should determine the suitability of the product for his intended use and assumes all risk and liability whatsoever in connection therewith.