

MagnaPro Fluorescent Luminaires

Installation Instructions

IF LBL1375

SAVE THESE INSTRUCTIONS FOR FUTURE REFERENCE

Mounting Instructions

It is strongly suggested to use two qualified trades people to proceed with the final mounting of the fixture to avoid any possible personnel injury or damage to the fixture and will be slightly awkward to hold into position and attach to brackets mounted on wall or ceiling. Depending on mounting height, scaffolding, hydraulic man-lift or two good quality ladders should be used.

No Brackets:

1. Make sure that the power is disconnected to the conduit system before installing the fixture.
2. Position fixture into desired location.
3. Drill at least four holes for (at least 1/4" bolts) through flange of fixture and into surface to be attached.
4. Fasten down fixture.
5. Power leads are shipped protruding from hub to reduce time of installation.
6. Make necessary wire connections. (Removal of lamps & reflector is optional, see maintenance)
7. Restore power to fixture.

MP1054MTK Brackets:

8. Make sure that the power is disconnected to the conduit system before installing the fixture.
9. Mark and drill holes to install brackets to wall or ceiling with two 1/4" bolts (not supplied)
10. Attach brackets to wall or ceiling. (Make sure that brackets are parallel to each other)
11. Fixture is now ready for mounting.
12. Lift fixture into position so that the flange fits into slots of brackets.
13. Tighten the set screws on brackets.
14. Power leads are shipped protruding from hub to reduce time of installation.
15. Make necessary wire connections. (Removal of lamps & reflector is optional, see maintenance)
16. Restore power to fixture

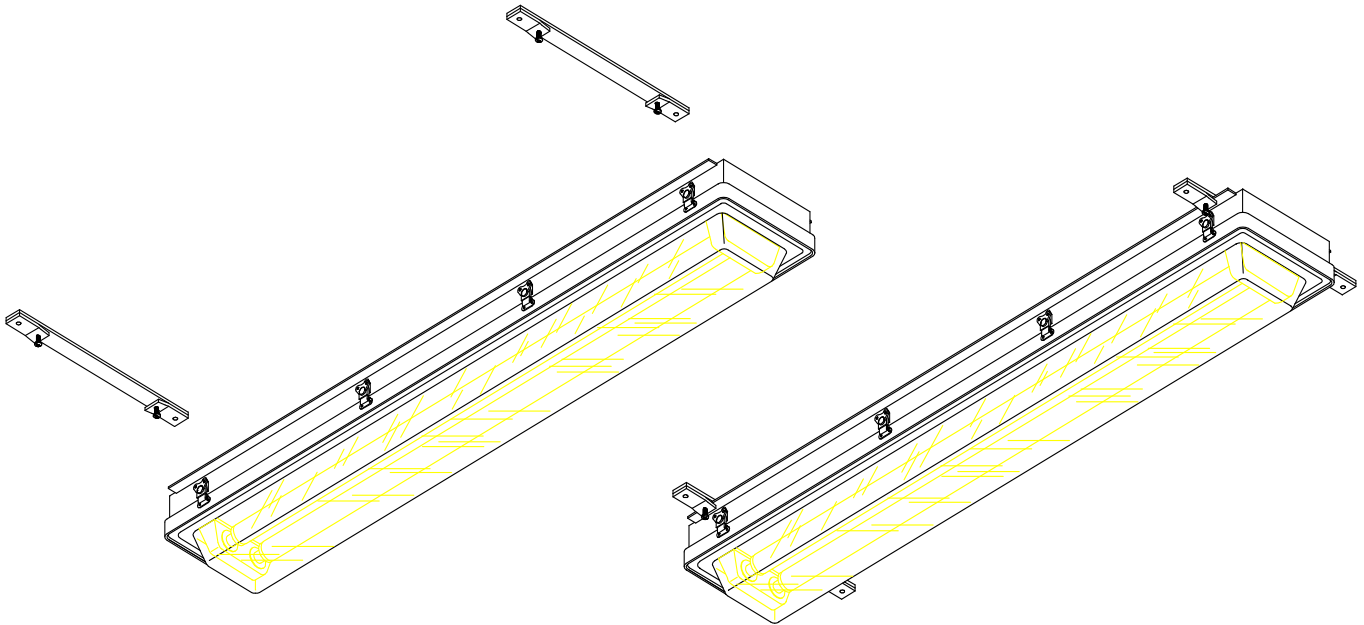

WARNING: To avoid the risk of severe electric shock, this unit must be properly grounded and the power disconnected prior to installing or servicing.

MagnaPro Fluorescent Luminaires

Maintenance Instructions

IF LBL1375

SAVE THESE INSTRUCTIONS FOR FUTURE REFERENCE

Note: All the following instructions are meant for skilled trades people only. We strongly recommend that only skilled trades people service this product.

The "MagnaPro" series of fixtures are an extruded aluminum fluorescent designed for long maintenance free life. The only components requiring replacement on a regular basis are the lamps. As most fluorescent lamps are designed for 20,000 + hour operation, replacement should be required every 3 to 4 years (based on a 15 hour operation per day).

A. Lamp replacement for F32T8 or F40T12 design

Tools required: no tools required for entry

1. **Turn off power source to fixture.**
2. Open fixture door by releasing catches on both sides and allowing door to open and to hang on hinges.
3. **Remove old lamp by rotating 90 degrees**, then lift lamp from socket and angle in fixture housing until it is clear of inner flange.
4. Replace both lamps (using lamps of equal specifications) to maintain maximum lumen output.
5. For installation of new lamps repeat procedure 3 in reverse making sure that the lamp is rotated 90 degrees in the socket to lock into place.
6. Close fixture door making sure the door is properly seated onto the housing flange for gasket seal, and **lock all latches by rotating a full 180 degrees from original position**.
7. Restore power to fixture.

B. Lamp replacement for two F48T12 design

Tools required: Insulated slotted screwdriver (if necessary).

1. Turn off power source to fixture.
2. Open fixture lens door by releasing catches on both sides and allowing door to open and to hang on hinges.
3. Depress spring-loaded sockets and remove lamp. If difficulty occurs, use **insulated screwdriver in between lamp and socket** to assist in lamp removal.

(Caution: Use of excessive force when replacing lamps may result in damage to sockets or lamps and may cause bodily injury.)

4. Replace both lamps (using lamps of equal specifications) to maintain maximum lumen output.
5. Close fixture lens doors making sure the door is properly seated on the housing flange for gasket seal and **close all latches by rotating a full 180 degrees from original position**.
6. Restore power to fixture.

C. Ballast replacement

Tools required: slotted screwdriver, wire cutters & compression tool if connectors are used.

1. **Turn off power source to fixture.**
2. Remove lamps as per above instructions.
3. Remove screws holding reflector in place (a single screw at each end) and remove reflector.
4. Disconnect power leads (black and white wires).
5. Cut leads from sockets to ballast at 6 inches (15 cm.) from ballast.
6. Remove screws holding ballast in place (a single screw at each end).
7. **Replace ballast with the same brand and rating to maintain the CSA approval on this product (not all ballasts are approved for use in hazardous area fixtures).** Consult factory before installing a ballast that is not identical.
8. Hold ballast in place and secure with a screw at each end.
9. Connect wires with an approved wire nut or compression connector making sure to match the same colored leads coming from each socket.
10. Connect power leads to ballast (black and white wires).
11. Replace reflector using the screws supplied (a single screw at each end).
12. Replace lamps as per above instructions.
13. Close fixture lens door making sure the door is properly seated on the housing flange for gasket seal and **close all latches by rotating a full 180 degrees from original position**.
14. Restore power to fixture.

All statements, technical information and recommendations contained herein are based on information and tests we believe to be reliable. The accuracy or completeness thereof are not guaranteed. In accordance with Crouse-Hinds "Terms and Conditions of Sale", and since conditions of use are outside our control, the purchaser should determine the suitability of the product for his intended use and assumes all risk and liability whatsoever in connection therewith.