

# IPE PENDANT MOUNT, EXACTA F701 SERIES FLUORESCENT LUMINAIRES

## Installation & Maintenance Information

### SAVE THESE INSTRUCTIONS FOR FUTURE REFERENCE

**CAUTION** Read carefully before installing and wiring the luminaire. These instructions include information for installation in both hazardous and ordinary locations. Any warning or special instructions should be closely followed. Hazardous area installations should be done in accordance with article 500 and 501 of the NEC or CEC. Intended for vertical mounting. Lamp base up only. Check the ratings to insure suitability for the area.

Must be installed in accordance with the NEC or CEC and all other applicable codes. All luminaires must be properly grounded. To reduce the risk of fire or explosion, do not install where the marked operating temperature exceeds the ignition temperature of the hazardous atmosphere. Disconnect the fixture from the supply circuit before opening. Keep tightly closed when in operation. These luminaires are provided with four 3/4" NPT knockouts. Do not attempt to install this luminaire unless you are familiar with warnings, cautions and procedures outlined in this information sheet.

### INSTALLATION & ELECTRICAL WIRING

**WARNING** Risk of electrical shock hazard, only qualified personnel should conduct this procedure! Do not make electrical connections with the power ON. Use cu or cu clad wire only, rated for 90°C.

1. Install conduit or fitting (not provided) into junction box (0A), tighten to assure a proper seal and lock in position with set screw (9E).
  2. Route supply cable thru conduit or fitting.
  3. Strip the supply cable(s) jacket (not provided) back approximately 3".
  4. Strip the insulation of the supply wires back approximately 3/8".
  5. Using connectors rated 90°C, connect the hot wire to black and the neutral to the white wire.
  6. Push connections inside junction box (0A).
  7. Align the holes in the base (1A) with the gasket (7B) and junction box (0A) holes. Install screws (9B) (qty 4, #8-32) in place and tighten to approximately 5 inch\*lbs.
- CAUTION** Use only compact fluorescent lamp to lampholder type and wattage rating indicated on the luminaire. Exceeding this can cause over heating, premature failure and be dangerous.
8. Install the lamp (4A) into the lampholder.
  9. Thread the glass globe (1B) clockwise into the base (1A), and tighten firmly by hand until the globe stops and seats well against the internal gasket.
  10. Thread the guard (2A) on clockwise and tighten firmly by hand.

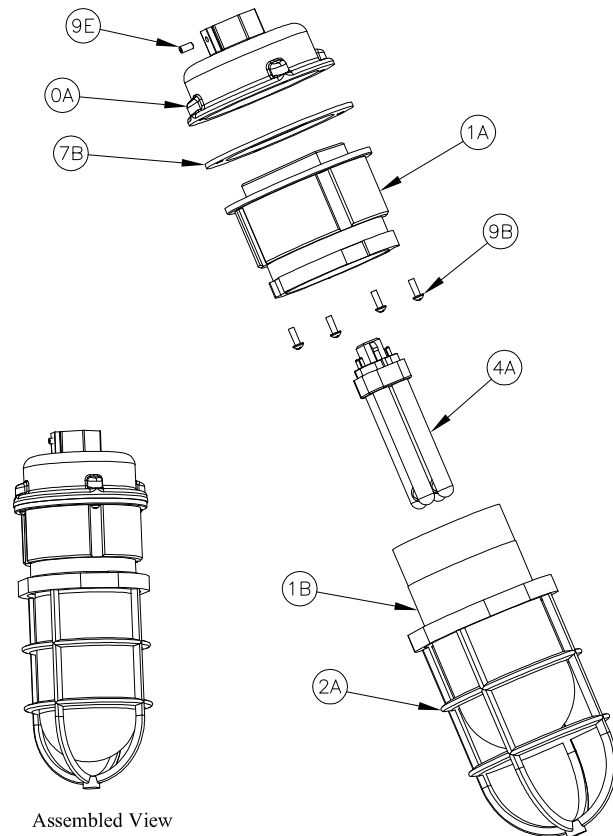

Assembled View

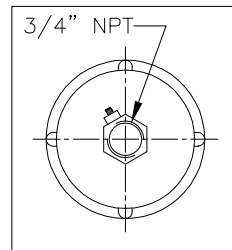

Mounting Dimensions

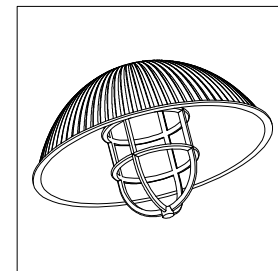

Option "RP" Prismatic Reflector

Spare Parts		
Item #	Description	Part Number
7B	Junction Box Gasket	GKT101-0002
1B	Glass Globe	INX2007*see note
2A	Plastic Guard	INXGP150
2A	Wire Guard	INXGW150
-	9w CF Lampholder	FX760-9400
-	13w CF Lampholder	FX4042
-	18w CF Lampholder	FX4030
-	26w & 32w CF Lampholder	FX4034
-	9w CF ballast	FX5086
-	13, 18, 26 & 32w CF ballast	FX5206
4A	9w CF lamp	FX3521
4A	13w CF lamp	FX3531
4A	18w CF lamp	FX3552
4A	26w CF lamp	FX3553
4A	32w CF lamp	FX3554

\*Add one of the following suffixes to the part number above to obtain the proper globe:  
 Clear - CLR    Red - RED    Green - GRN  
 Blue - BLU    Amber - YEL    Clear HR - HR

All statements, technical information and recommendations contained herein are based on information and tests we believe to be reliable. The accuracy or completeness thereof are not guaranteed. In accordance with Crouse-Hinds "Terms and Conditions of Sale", and since conditions of use are outside our control, the purchaser should determine the suitability of the product for his intended use and assumes all risk and liability whatsoever in connection therewith.