

707F SERIES INCANDESCENT LUMINAIRES

Installation & Maintenance Information

IF LBL1386

SAVE THESE INSTRUCTIONS FOR FUTURE REFERENCE

CAUTION Read carefully before installing and wiring the luminaire. Check the ratings to insure suitability for the area. Must be installed in accordance with the NEC (National Electrical Code) and all other applicable codes. All luminaires must be properly grounded. These luminaires are not suitable for hazardous locations. These luminaires are not typically provided with cable entry holes.

All holes added should be done by qualified personnel through the thickened areas of the junction box suitable for threading. The junction box can be drilled and tapped a maximum of (4) places, up to a maximum 1"NPT. Do not attempt to install this luminaire unless you are familiar with warnings, cautions and procedures outlined in this information sheet.

INSTALLATION & ELECTRICAL WIRING

WARNING Risk of electrical shock hazard, only qualified personnel should conduct this procedure!
Do not make electrical connections with the power ON. Use cu or cu clad wire only, rated for 105°C.

1. Make the 4-5/8" cut out and mounting hole locations as per the illustration below.
2. Install cable gland(s) (not provided) into junction box (0A) and assure a proper seal as per the manufacturers instructions.
3. Strip the supply cable(s) jacket (not provided) back approximately 15", route cable(s) thru the gland and tighten as per the manufactures instructions to create a proper seal. Attach the ground wire to the green screw (9D) in junction box (0A).
4. Mount junction box (0A) and gasket (7C) with (4) minimum size #10 screws.
5. Route the cable thru the junction box gasket (7B) and thru the 90° adapter (1B). Align the holes in the 90° adapter with the gasket (7B) and junction box (0A) holes. Install screws (9B) (qty 4, #10-24) in place and tighten to approx. 12-15 in/lbs. For aluminum fixtures, apply the lubricant provided to the screw threads.
6. Install gasket (7A) into the 90° adapter (1B) and align the (4) holes to accept the lampholder screws.
7. Strip the insulation of the supply wires back approximately 3/8".
8. On the back of the lampholder (4B), connect the black hot lead(s) to the dark colored screws contacts, connect the white neutral lead(s) to the light colored screw contacts. Tighten screws to approximately 8-10 in/lbs.
9. Install screws (9C) (qty 4, #8-32), passing them thru the lampholder (4B), gasket (7A) and thread into the 90° adapter (1B). Tighten to approximately 10 in/lbs. For aluminum fixtures, apply the lubricant provided to the screw threads.
- CAUTION** Note maximum lamp wattage rating as indicated on the luminaire. Exceeding this can cause over heating, premature failure and be dangerous. The lampholder is rated for a maximum of 600 volts. The voltage of the lamp must correspond with the supply voltage.
10. Install the proper wattage lamp (not provided) into the lampholder, making sure the center contact of the lamp seats well into the lampholder.
11. Thread the glass globe (1A) clockwise into the 90° adapter (1B), and tighten firmly by hand until the globe stops and seats well against the internal gasket.
12. Thread the guard (2A) on clockwise and tighten firmly by hand. For aluminum fixtures, apply the lubricant provided to the threads of the guard. (Luminaires with option "PG" plastic globes, the guard (2A) is not provided)

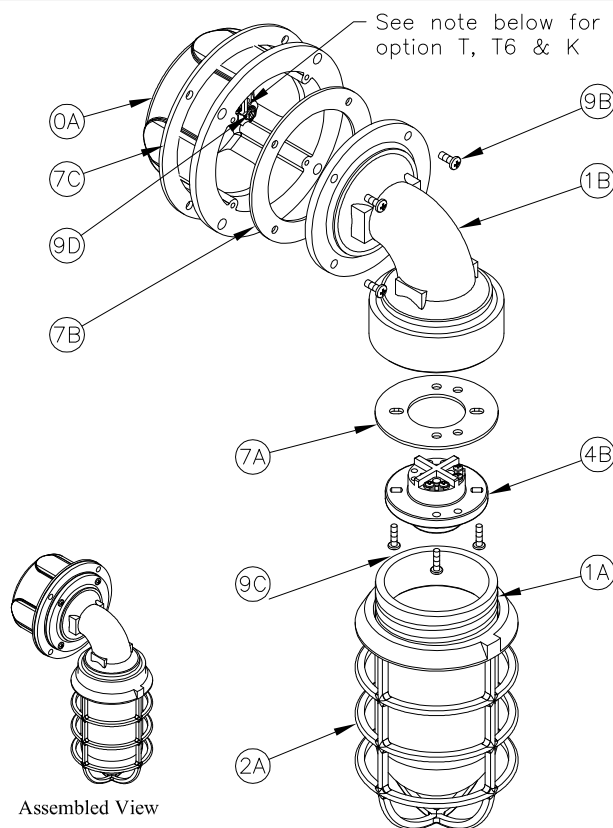

Assembled View

Spare Parts		
Item #	Description	Part Number
7B	Junction Box Gasket	GKT3000SIL
7C	Junction Box Mntg. Gasket	GKT3005
7A	Globe Gasket	GKT2002SIL
4B	Lampholder	INX4000
1A	100 watt 6" Globe	INX2006* see note
1A	150 watt 7" Globe	INX2007* see note
2A	100 watt 6" Guard	INX1036A or B**
2A	150 watt 7" Guard	INX1037A or B**

*Add one of the following suffixes to the part number above to obtain the proper globe:
Clear - CLR Blue - BLU Clear HR - HR
Frosted - FST Green - GRN Red - RED
Yellow - YEL
**A = Aluminum B = Brass

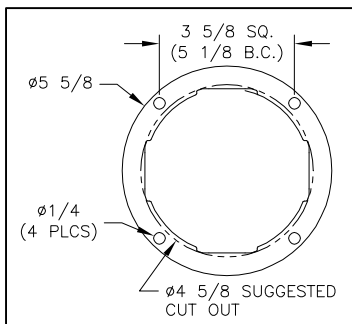

Mounting Dimensions

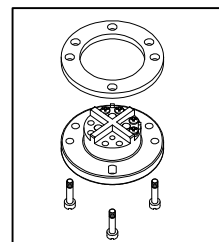

Option "SP" for shock proof lamp holder

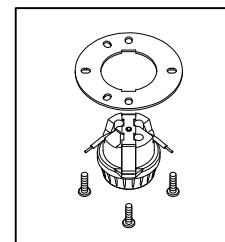

Option "P" for porcelain lampholder

Note: If luminaire is provided with terminal block, (option T or T6), connect incoming black and white supply leads to the screws adjacent to the black and white wires on the terminal block. Connect the black and white wires from the terminal block to the back of the lampholder as per step 8 above. If provided with option "K" for a double pole switch, connect the black and white supply leads to the 2 leads on one side of the switch. Connect the 2 leads on the other side of the switch to the lampholder contacts as per step 8 above.

All statements, technical information and recommendations contained herein are based on information and tests we believe to be reliable. The accuracy or completeness thereof are not guaranteed. In accordance with Crouse-Hinds "Terms and Conditions of Sale", and since conditions of use are outside our control, the purchaser should determine the suitability of the product for his intended use and assumes all risk and liability whatsoever in connection therewith.