

**Meridian FDA Series: White and RV-1(Combo) Emergency Luminaire, Inside Drip-proof Type  
Installation & Maintenance Information**

**IF 1898**

**SAVE THESE INSTRUCTIONS FOR FUTURE REFERENCE**

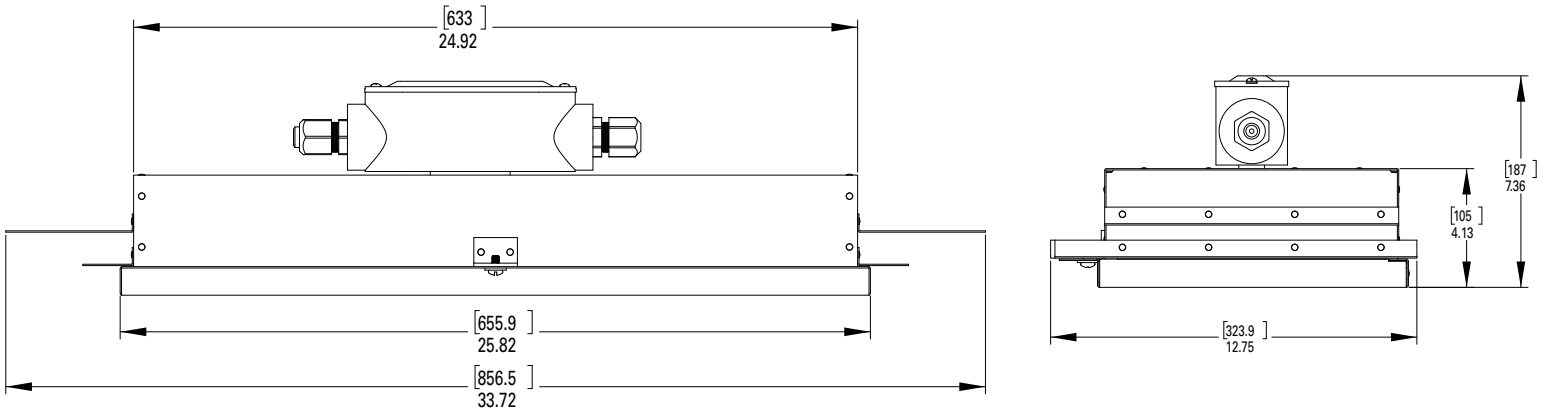

**IMPORTANT SAFEGUARDS – READ AND FOLLOW ALL SAFETY INSTRUCTIONS**

When using electrical equipment, basic safety precautions should always be followed, including the following:

**IMPORTANT**

Emergency lighting system should be installed, inspected, operated and maintained by qualified and competent personnel.

**⚠ WARNING**

**To avoid personal injury, fire, shock and/or equipment failure,**

- Do not use this equipment for other than intended use.
- Make sure the supply voltage is the same as the equipment voltage.
- Do not operate in ambient temperatures above those indicated on the equipment nameplate.
- Use proper supply wiring as specified on the equipment nameplate.
- Electrical power must be turned OFF before and during installation and maintenance. Keep tightly closed when in operation.
- Install only wiring systems with an equipment grounding conductor (which may be the conduit system).
- Do not use accessory equipment not recommended by the manufacturer.
- All gasket seals must be clean and undamaged.
- Use only replacement parts from Eaton’s Crouse-Hinds Division.

**⚠ WARNING**

**To avoid personal injury or equipment failure,**

Equipment should be mounted in locations and at heights where it will not readily be subjected to tampering by unauthorized personnel.  
Do not mount near heat-producing equipment.

1. Replace entire battery and driver unit when necessary. Contact the manufacturer for information on service.
2. Do not attempt to service battery.

**SAVE THESE INSTRUCTIONS**

1. Read carefully before installing and wiring luminaire and retain for future reference.
2. Check the label rating to ensure the luminaire is suitable for the environment and supply.
3. The luminaire should be installed in accordance with the National Electrical Code and any codes having jurisdiction over the installation area.
4. Disconnect the luminaire from the supply circuit before opening. Keep tightly closed when in operation.
5. See product label for minimum supply wire temperature rating.
6. All luminaires must be properly grounded.
7. See product label for maximum ambient temperature.
8. Under NO circumstances should the internal reflector be opened or removed during operation.
9. All wiring should be done by qualified electricians only!
10. Do not attempt to make electrical connections with the power ON. See product label for input and amperage load per luminaire.
11. Do not mount near gas or electric heaters.
12. Do not use this emergency driver for other than intended use.
13. Battery is rechargeable LiFePO4 type and must be recycled or disposed of properly.
14. Do not attempt to touch LEDs.
15. AC power must be off before proceeding with assembly, installation or servicing of emergency driver.
16. The emergency battery requires a minimum charge time of one (1) hour before testing the circuit. A minimum of twelve (12) hours is required for a full charge.
17. BATTERY DISABLE PROCEDURE: Unit must be powered within 6 months. To ship a luminaire with the battery connected without draining the battery the procedure is: a. Driver is installed in a luminaire. b. Battery is switched to the “ON” position. c. Luminaire is powered and tested. d. Luminaire is un-powered; the unit enters Emergency mode. e. Battery is switched to “OFF”; wait about 3 seconds then switch the battery back to the “ON” position.
18. Not recommended for installations where unit will be without power for more than 6 months.

## INSTALLATION

### Maximum mounting height: 15 ft. (4.57 m)

Do not attempt to install luminaire unless you are familiar with the warnings, cautions and procedures outlined in this instruction sheet.

1. Remove luminaire from carton, undo the latches holding the lens in place, remove and dispose of protective plastic covering the lens, replace lens, secure with latches.
2. Position the luminaire onto the intended mounting surface.
3. Secure the luminaire in place with a minimum 1/4" diameter size bolt and flat washer through the hole provided in each mounting leg. Mounting hardware is not provided. NOTE: all four (4) mounting legs must be secured.
4. Drill (2x) mounting holes for minimum 1/4" bolts through each suspension bracket (1A). Clean all foreign material.
5. Mount luminaire to ceiling system track (3B) in its intended location using minimum 4x, 1/4" bolts, nuts & washers (not provided).
6. Remove conduit box cover (4A) by removing screw (4C), then remove cable connector (4B) to supply wires through and make connections in conduit box. Tighten cable connector (4B) with 90 in-lbs torque and close the conduit box cover (4A) using screw (4C) to complete the connections to luminaire.

Note: This luminaire is listed as "Marine Inside Drip-proof", consideration should be given when selecting cord grips to ensure a drip-proof seal around the cable.

### IMPORTANT

In RV-1 (Combo) version, illuminate one color at a time (either RED or WHITE), illuminating both colors at a time may compromise product performance over time due to excessive heating of the internal components.

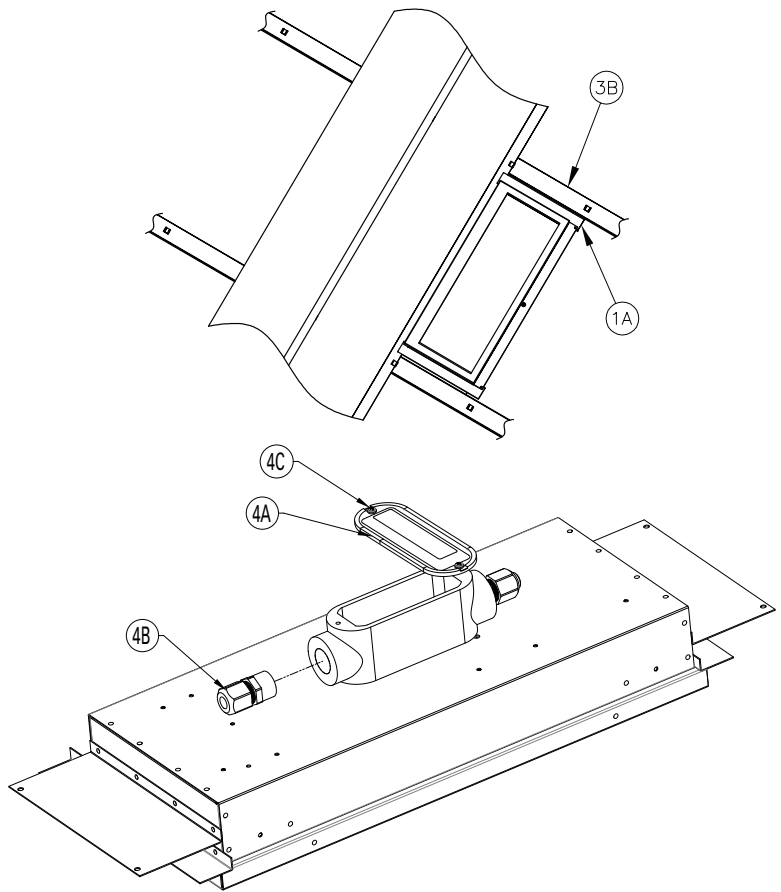

**These instructions are dimensional and orientation information for proper mounting of FDA Parallel Type to 300mm suspended ceiling system. See page 3 & 4 for electrical wiring.**

1. Verify ceiling panel size (5A). See Figure 3.

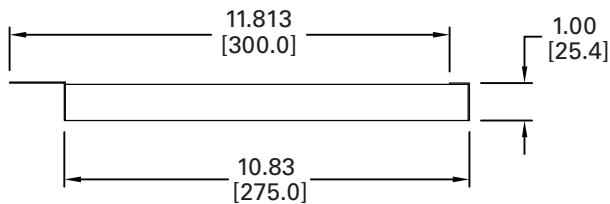

Figure 1. Side view

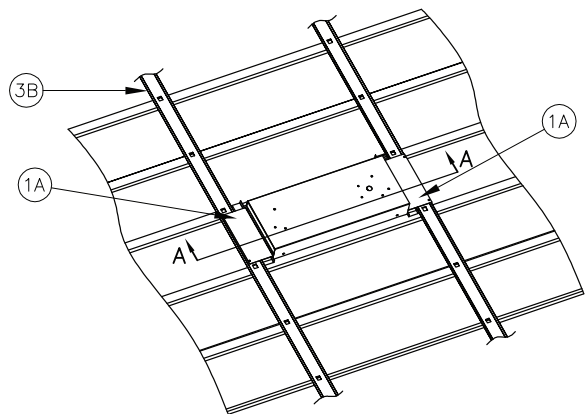

Figure 1. From Above

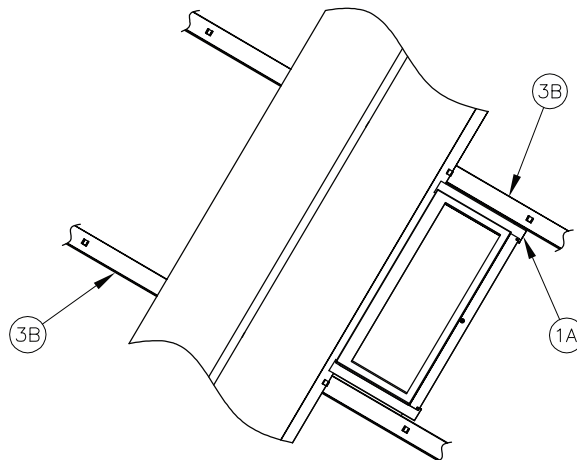

Figure 2. From Below

- Luminaire lens frame (4A) is 10.83" wide. Position luminaire for lens frame (4A) to takes the spacing of 1x ceiling panel (5A). Maintain 1" gap between ceiling panel and lens frame on either side.

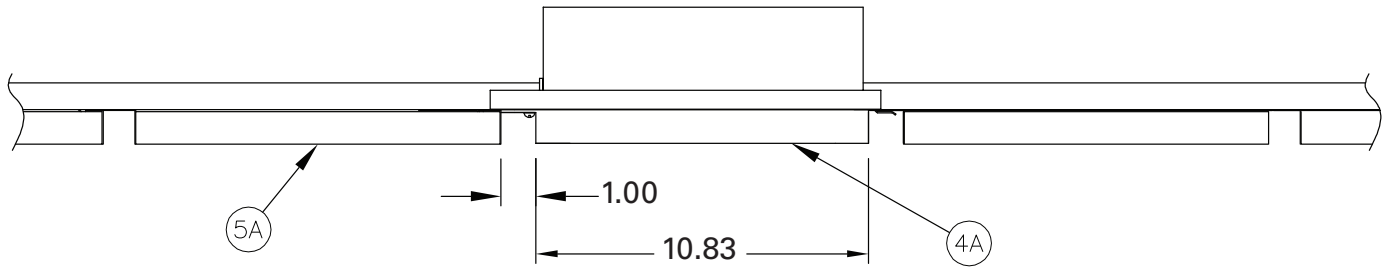

Figure 2. End View

- Install luminaire (1B) to ceiling system track (3B) using minimum 4x, 1/4" bolts, nuts & washers (not provided).

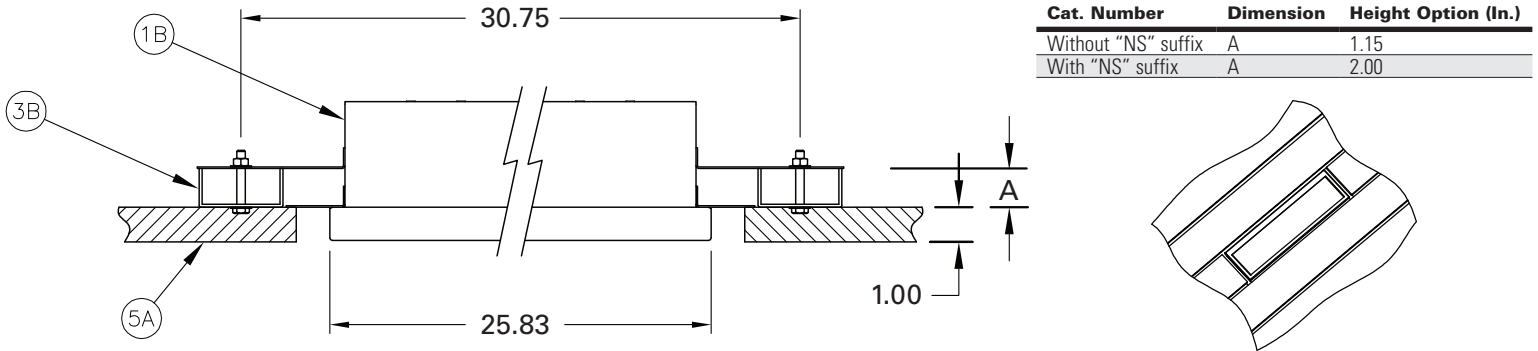

Figure 3.

- Return to Page 2 to complete installation.

## OPERATION

After all mounting and electrical work has been completed and the luminaire is properly closed, power can be applied, and the luminaire inspected for proper operation.

## EMERGENCY DRIVER INFORMATION

FDA emergency luminaires are supplied with an emergency driver. Disconnect the battery/converter connector prior to performing maintenance. This will disconnect the charged battery from the LEDs. The emergency driver must be checked periodically to ensure that it is working properly.

## PERIODIC TESTING

Article 700 of the National Electrical Code® states, "Systems shall be tested periodically on a schedule acceptable to the authority having jurisdiction to assure their maintenance in proper operating condition." Also, "A written record shall be kept of such tests and maintenance"

In the absence of periodic testing requirements by a local authority, the following recommendations from the NFPA 101 (20 03) Life Safety Code are strongly recommended:

- Monthly: Visually inspect the charging indicator light. It should be illuminated when AC power is applied. Momentarily operate push-to-test switch. Observe that emergency luminaires are on full brightness for the entire test cycle. Record the test on the Maintenance Record Card (provided on next page).
- Annually: Shut off AC power at the distribution panel. Verify that the emergency luminaires remain "ON " for a minimum of 180 mins.

NOTE: We suggest that this test be continued until the power supply automatically shuts the emergency light(s) off. This will help maintain full battery capacity.

Record the test on the Maintenance Record card.

Allow 24 hours charging time before depending on the battery to operate at full capacity.

Failure to function properly in either test may indicate the need for EM driver replacement.

## TEST SWITCH INDICATOR STATUS

LED Indicator Status	EM Driver Status/Mode
Solid Green	System OK/AC OK
Slow Flashing Red, 4s on/1s off	Battery not detected, check battery switch or connection
Flashing Red, 1s on/1s off	Battery Failure, replace battery
Flashing Green, 1s on/1s off	Self-Diagnostic test underway
Fast Flashing Red, 0.1s on/0.1s off	Abnormal driver performance, replace driver
Very Slow Flashing Red, 4s on/4s off	Over temperature
None. Both LEDs OFF	Normal working in EM mode
Green/Red alternative flashing, 1s green/1s red.	No load or output over voltage protection triggered

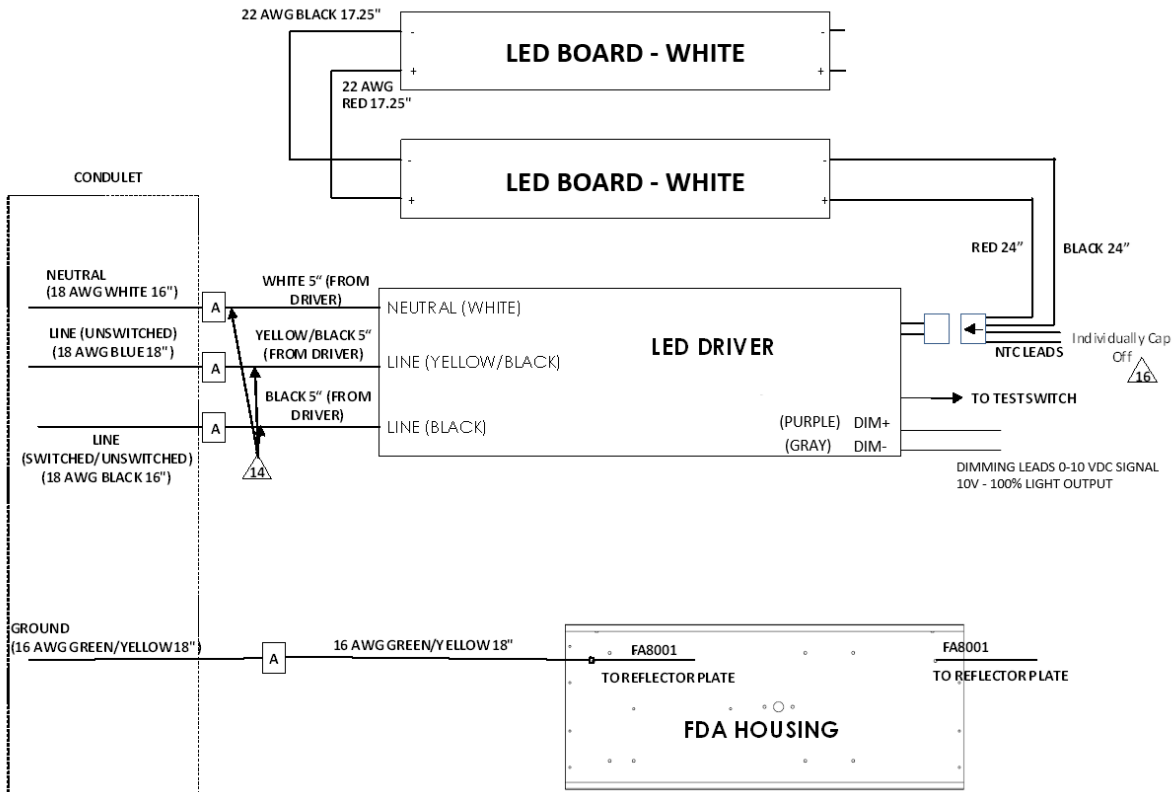

Wiring diagram for white luminaire

**A** - 2 POLE WAGO CONNECTORS

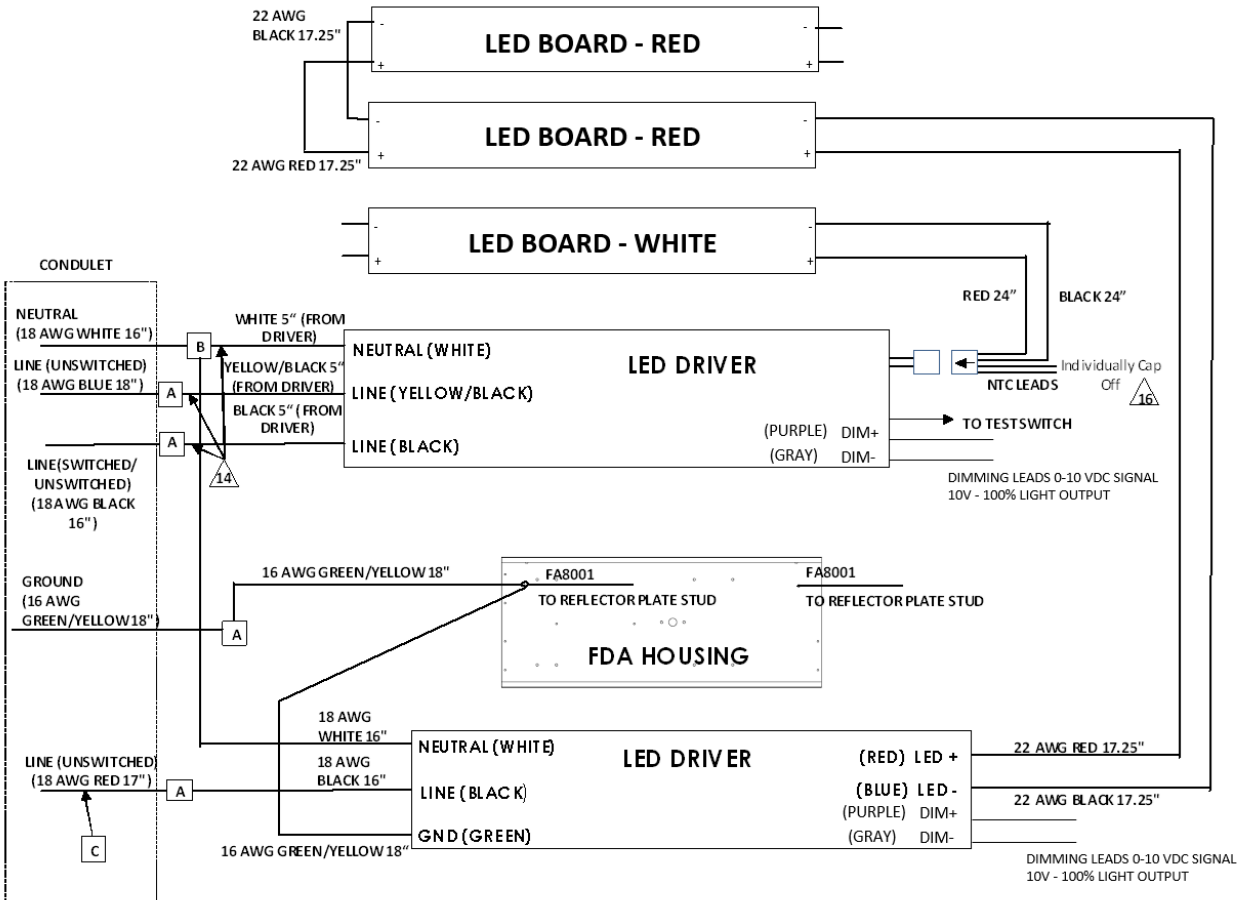

Wiring diagram for RV-1 (Combo) Luminaire

**A** - 2 POLE WAGO CONNECTORS  
**B** - 3 POLE WAGO CONNECTORS

**MAINTENANCE GENERAL**

1. Perform visual, electrical and mechanical inspections on a regular basis. The environment and frequency of use should determine this. However, it is recommended that checks be made at least once a year. We recommend an Electrical Preventive Maintenance Program as described in the National Fire Protection Association Bulletin NFPA No. 70B: Recommended Practice For Electrical Equipment Maintenance (www.nfpa.org).
2. The lens should be cleaned periodically to ensure continued lighting performance. To clean, wipe the lens with a clean, damp cloth. If this is not sufficient, use a mild soap or a liquid cleaner such as Collinite NCF or Duco #7. Do not use an abrasive, strong alkaline, or acid cleaner. Damage may result.
3. Visually check for undue heating evidenced by discoloration of wires or other components, damaged parts or leakage evidenced by water or corrosion in the interior. Replace all worn, damaged or malfunctioning components, and clean gasket seals before putting the luminaire back into service.
4. Electrically check to make sure that all connections are clean and tight. Mechanically check that all parts are properly assembled.
5. Check and re-torque all mounting hardware.
6. To prevent heat build-up, remove dust from the LED housing using a soft brush or air pressure.

**REPLACEMENT PARTS**

Eaton's Crouse-Hinds series linear LED luminaires are designed to provide years of reliable lighting performance. However, should the need for replacement parts arise, they are available through your authorized Eaton's Crouse-Hinds distributor. Assistance may also be obtained through your local Eaton's Crouse-Hinds representative or the Eaton's Crouse-Hinds Sales Service Department, 1201 Wolf Street, Syracuse, New York 13208, Phone 866-764-5454.

**MAINTENANCE RECORD**

Date	Duration of Test			EM Driver Replaced	Inspected By	Record Luminaire Location	Notes
	30 Sec.	180 Mins.	Other				

All statements, technical information and recommendations contained herein are based on information and tests we believe to be reliable. The accuracy or completeness thereof are not guaranteed. In accordance with Eaton's Crouse-Hinds Division's "Terms and Conditions of Sale," and since conditions of use are outside our control, the purchaser should determine the suitability of the product for his intended use and assumes all risk and liability whatsoever in connection therewith.