

SAVE THESE INSTRUCTIONS FOR FUTURE REFERENCE

APPLICATION

Dust cover kit for IHB LED Luminaire.

- Suitable for operation in ambient -40°C to 60°C
- IP 4X
- Suitable for damp locations

⚠ WARNING

To avoid the risk of fire, explosion, or electric shock, this product should be installed, inspected, and maintained by a qualified electrician only, in accordance with all applicable electrical codes.

⚠ WARNING

To avoid electric shock:

- Be certain electrical power is OFF before and during installation and maintenance.
- Luminaire must be supplied by a wiring system with an equipment grounding conductor.

To avoid burning hands:

- Make sure luminaire lens and housing are cool when installing and performing maintenance.

IHB Configuration	1/4-20 Screw quantity	8-32 Screw Quantity
8L	4	10
16L	4	10
24L	6	10
32L	6	10
48L	10	10
64L	10	10

Chart 1

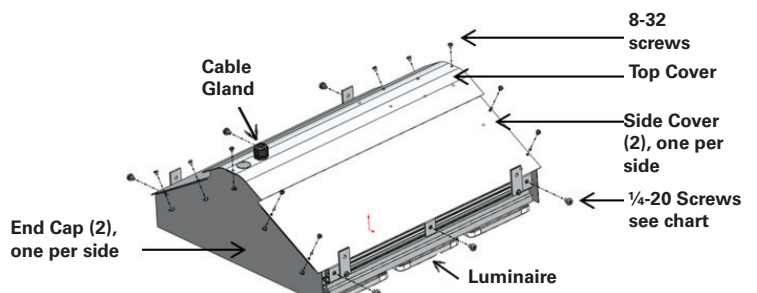

Figure 1

INSTALLATION

DUST COVER

⚠ WARNING

Wear proper protection equipment when working with sheet metal parts.

1. Install 1 side cover to the luminaire using the 1/4-20 screws provided with the dust cover, see figure 1. Screws will self-thread into the grooves on the sides of the luminaire, see figure 4. Tighten screw until flush with surface (25 in-lbs). The quantity of screws holding the cover to the luminaire varies depending on the Lumen configuration, see Chart 1.
2. Install the second side cover to the luminaire using the 1/4-20 screws provided with the dust cover and tighten to 25 in-lbs.
3. Install the end caps of the dust cover to the sides of the dust cover using the 8-32 screws and nuts provided (4 screws and 4 nuts per end) and tighten to 20 in-lbs.
4. Route the wire(s) from the luminaire thru the gland in the top of the dust cover and place the top cover onto the dust cover end caps and secure with the two 8-32 screws and nuts to 19 in-lbs.
5. Tighten the cable gland to secure the cable.
6. Refer to IF 1726 for more additional information on Installation and Maintenance.

DUST COVER CONFIGURATIONS WITH PENDANT MOUNT

1. Install the pendant mount bracket with the hardware provided, (4) 1/4-20 screws, See figure 2. Center the pendant mount bracket on luminaire, see Figure 2. Measure from each end of the luminaire to the edge of the pendant mount on each side. The distance from side to side should be equal or within 1/16" to each other. Tighten the 1/4-20 screws to 65 in-lbs and tighten the 10-24 screws to 21 in-lbs. **DO NOT REMOVE MOUNTING TAB RETENTION SCREWS.** If mounting tab retention screws are removed, make sure to re-install and tighten to 65 in-lbs torque.
2. Thread the lock nut onto the appropriate 3/4" NPT conduit all the way up the threads, see figure 3.
3. Place the luminaire onto the conduit using the hole located in the center of the pendant mount bracket. Install the throat bushing and tighten to 42 ft-lbs. Rotate the luminaire to the proper alignment before securely tightening the locknut (hand tight plus a quarter turn). Tighten lock screw in the throat bushing to 9 in-lbs, see figure 3.
4. Route the wires from the gland in the dust cover to the conduit.

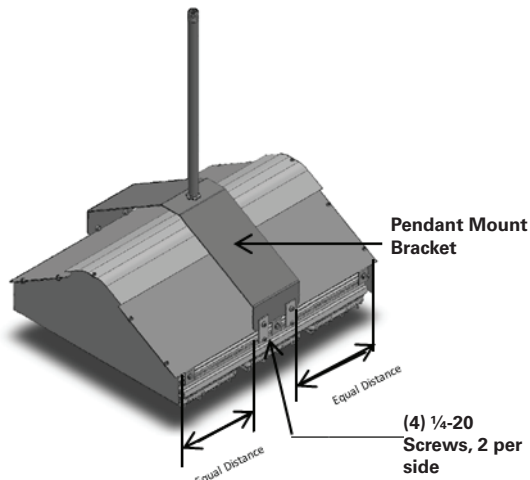

Figure 2

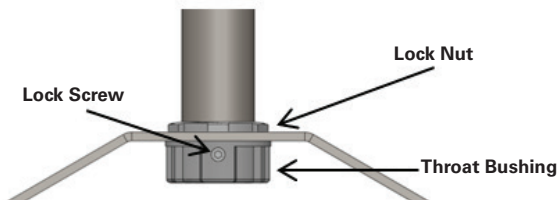

Figure 3

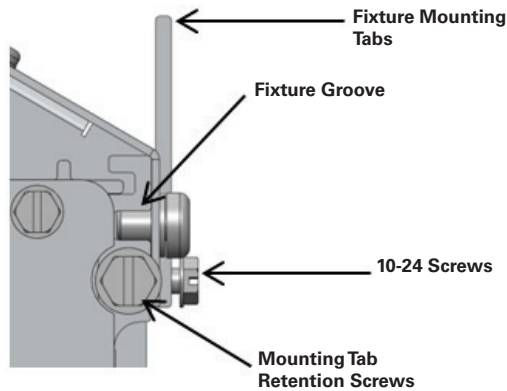

Figure 4

assembly to assure the luminaire hangs level. Mount the luminaire a minimum of 36 inches away from the ceiling. Refer to B-Line FIS-164 Instruction Sheet for further details and information.

- Use the factory installed wire (SOOW cable) for electrical connection to the appropriate junction connection. See the wiring section in IF1726 for more information.

JACK CHAIN MOUNTING

- Mounting tabs are located 1" from each end of the luminaire from the factory, see figure 4. If mounting tabs need to be relocated or become loose then tighten the 10-24 screws to 21 in-lbs before hanging the luminaire. Mounting tab retention bolts should be tightened to 65 in-lbs in all four corners of the luminaire. Mounting tabs should be placed equal distance from the ends of the luminaire to assure the luminaire hangs level.
- Chains should be cut to equal lengths to assure the luminaire hangs level. Install (4) hooks and (4) chains to the luminaire. One hook and one chain per mounting bracket found at each corner of the luminaire. Mount the luminaire a minimum of 36 inches away from the ceiling.
- Use the factory installed wire (SOOW cable) for electrical connection to the appropriate junction connection. See the wiring section in IF1726 for more information.

IHB Dust Cover Kit	IHB Lumen Configuration
IHB8L DC1 KIT	8L
IHB16L DC1 KIT	16L
IHB24L DC1 KIT	24L
IHB32L DC1 KIT	32L
IHB48L DC1 KIT	48L
IHB64L DC1 KIT	64L

AIRCRAFT CABLE MOUNTING

⚠ WARNING

Aircraft cable mounting is intended for dry locations only.

- Mounting tabs are located 1" from each end of the luminaire from the factory. If mounting tabs need to be relocated or become loose then tighten the 10-24 screws to 21 in-lbs (see figure 4) before hanging the luminaire. Mounting tab retention bolts should be tightened to 65 in-lbs in all four corners of the luminaire. Mounting tabs should be placed equal distance from the ends of the luminaire to assure the luminaire hangs level.
- Install (2) aircraft cable assemblies to the luminaire with one aircraft cable assembly at each end of the luminaire, refer to IF1726 for more information. Do not exceed an angle greater than a 30° between the cables and the gravity line. Adjust the length of the aircraft cable

All statements, technical information and recommendations contained herein are based on information and tests we believe to be reliable. The accuracy or completeness thereof are not guaranteed. In accordance with Crouse-Hinds "Terms and Conditions of Sale," and since conditions of use are outside our control, the purchaser should determine the suitability of the product for his intended use and assumes all risk and liability whatsoever in connection therewith.