

### SAVE THESE INSTRUCTIONS FOR FUTURE REFERENCE

#### APPLICATION

LED floodlight construction is designed for use indoors and outdoors in marine and wet locations, where moisture, dirt, corrosion, vibration and rough usage may be present.



#### NFMV:

#### IECEX:

- IEC, ATEX:
- IECEX UL 15.0040X
- DEMKO 15 ATEX 1226X
- DEMKO 15 ATEX 1225X
- Ex nA IIC T4 Gc Tamb -30°C - +55°C
- Ex tb IIIC T76 Db Tamb -30°C - +40°C
- II 3 G Ex nA IIC T4 Gc Tamb -30°C to +55°C
- II 2 D Ex tb IIIC T76C Db IP66 Tamb -30°C to +40°C

Refer to the floodlight nameplate for specific classification information, maximum ambient temperature suitability and corresponding operating temperature (T-number).

#### IEC STANDARDS:

- IEC 60079-0:2011/EN60079-0:2012+A11:2013
- IEC 60079-15:2010/EN60079-15:2010
- IEC 60079-31:2008/EN60079-31:2009
- IEC 60598-1:2008/EN60598-1:2008
- IEC 60598-2:2008/EN60598-2:2008
- IEC 61184, IEC 60238, IEC 60400, IEC 61347-1,
- IEC 61347-2-1, IEC 61347-2-2, IEC 61347-2-3,
- IEC 61347-2-4, IEC 61347-2-7, IEC 61347-2-8,
- IEC 61347-2-9, IEC 61048, IEC 60155,
- IEC 60927, and IEC 60998-2-4.
- Wet Locations
- IP66

#### LED floodlights are supplied for use with a choice of voltages:

- 100-277 VAC, 50/60 Hz and 108-250 VDC
- 277-480 VAC, 50/60 Hz

LED floodlights are compliant with the regulation on the assessment of product compliance for explosive atmospheres according to INMETRO Directive No. 179/2010 and compliant with IEC Standards 60079-0:2007 and 60079:2010.

#### ⚠ WARNING

To avoid the risk of fire, explosion or electric shock, this product should be installed, inspected and maintained by a qualified electrician only, in accordance with all applicable electrical codes.

#### ⚠ WARNING

##### To avoid electric shock:

Be certain electrical power is OFF before and during installation and maintenance.

##### To avoid burning hands:

Make sure lens and housing are cool when performing maintenance.

#### ⚠ WARNING

##### To avoid potentially unsafe operating conditions:

- Before opening, electrical power to the floodlight must be turned off. Keep tightly closed when in operation.
- Make sure the supply voltage is within the floodlight voltage range stated on the nameplate.
- Do not operate in ambient temperatures above those indicated on the floodlight nameplate.
- Use only replacement parts from Eaton's Crouse-Hinds Business.
- Use proper supply wiring as specified on the floodlight nameplate.
- All gasket seals must be clean and properly positioned.
- Do not position the floodlight beyond the aiming range limits.
- Do not exceed the maximum allowable current draw of 15 amps when daisy chaining floodlights (S886 configuration only).

#### ⚠ WARNING

##### To avoid potentially unsafe harm to eyes:

Mount at a minimum recommended height of 20 ft. (6m) - 7x6 optic; 60 ft. (18m) - 3x3 optic.

#### SPECIAL CONDITIONS OF SAFE USE

##### DO NOT OPEN WHEN ENERGIZED

##### POTENTIAL ELECTROSTATIC CHARGING HAZARD

"To reduce the risk of ignition due to electrostatic discharge, avoid contact with the luminaire while an explosive atmosphere is present. Clean only with a damp cloth."

Do not aim light 90° past or before vertical (see Figure 3).

#### INSTALLATION

##### Mounting

##### YOKE MOUNT – POST MOUNT USING FLOODLIGHT YOKE ONLY

1. Select a durable, corrosion-resistant mounting surface capable of supporting the fixture's 50 lb. (22.7 kg.) weight and cantilevered mass (as applicable) (see Figure 1).

2. Using the floodlight yoke as a template, mark and drill desired location on mounting surface.
3. Secure floodlight yoke to mounting surface by applying proper torque to corrosion-resistant 1/2 inch (12mm) bolts or lag screws accompanied by lock washers.
4. Ensure that the safety chain is securely fastened between the yoke bracket and back cover.

#### WIRING

##### Wiring the Floodlight

1. All components in the fixture are pre-wired so only line in, neutral and ground need to be connected in the fixture to the terminals per the wiring diagrams using methods that comply with all applicable codes. Use 16 AWG (1.3 mm<sup>2</sup>) minimum for grounding wires. Use 18 AWG (0.82mm<sup>2</sup>) minimum for common and line wires. Use supply cord with outer sheath diameter in accordance with Table 1. Terminate the equipment grounding conductor (green) first, the common (white) next, and finally, the line voltage (black) last. Secure all electrical connections and wiring entry glands (see Figure 2).

Table 1

Gland Name	PFM25L Ordering Suffix	Thread Type	Cable Diameter Range
CAP816604	M20	M20 x 1.5	8.5 - 16.0mm (0.34 - 0.62 in)
CAP816794	M25	M25 x 1.5	8.5 - 16.0mm (0.34 - 0.62 in)

Input wire location  
M25 x 1.5 for suffix M25  
M20 x 1.5 for suffix M20

Ground Lug Location  
(Torque to 35 in.-lbs.)

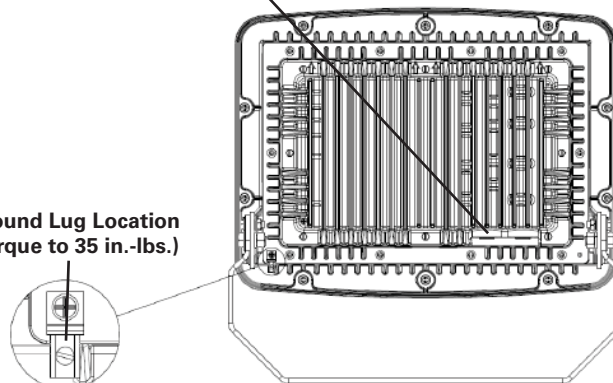

Figure 1

## WIRING DIAGRAM

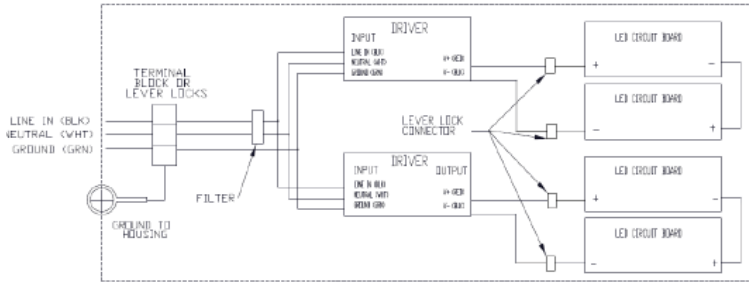

Figure 2

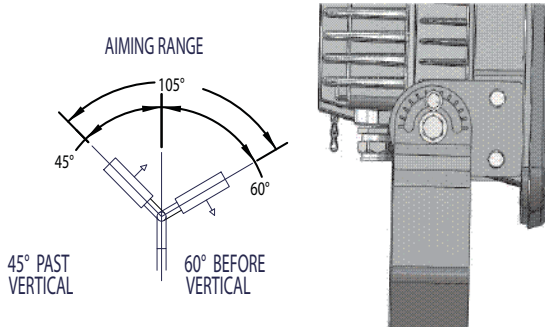

Figure 3

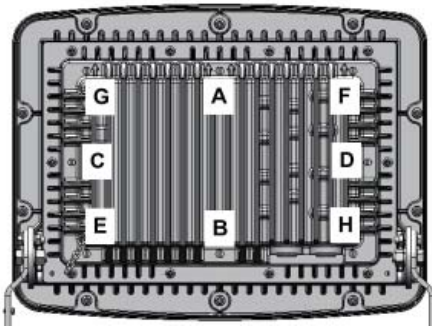
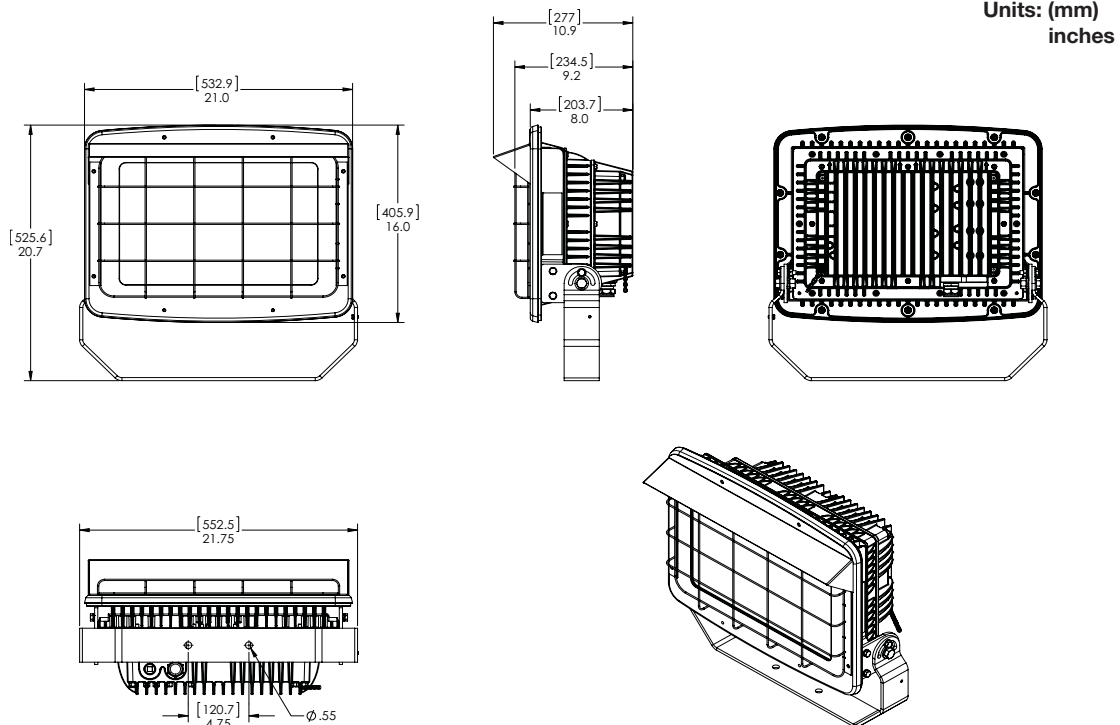

Figure 4

## DIMENSIONS



2. Ensure gasket joint, back cover and driver housing surfaces are clean and free of damage and debris. Put back cover in place on driver housing and start all eight (8) back cover screws hand tight. Initially torque back cover screws to 40 in.-lbs. (4.5 N-m) in sequence of A-B-C-D-E-F-G-H as shown in Figure 4. Next, torque back cover screws up to 79 in.-lbs. again in sequence of A-B-C-D-E-F-G-H. Finally, torque screws through A-B-C-D-E-F-G-H sequence one final time and ensure torque values are at 79 in.-lbs. (8.9 N-m).
3. To make final vertical adjustment, loosen the pivot bolts on the floodlight yoke to position floodlight at the desired angle (limited to 60 degrees forward and 45 degrees back, as shown in Figure 3).
4. Rotate the floodlight housing to the desired position.
5. Tighten the two (2) 1/2"-13 bolts to 45 ft.-lbs. (61.0 N-m). Tighten the 5/16"-18 bolts in the adjustment slots to 12 ft.-lbs. (16.3 N-m).
6. Turn power on.

## MAINTENANCE

- Perform visual, electrical and mechanical inspections on a regular basis. The environment and frequency of use should determine this. However, it is recommended that checks be made at least once a year. We recommend an Electrical Preventive Maintenance Program as described in the National Fire Protection Association Bulletin NFPA 70B: Recommended Practice for Electrical Equipment Maintenance ([www.nfpa.org](http://www.nfpa.org)). Use a damp cloth when cleaning floodlight surfaces.
- The lens should be cleaned periodically to ensure continued lighting performance. To clean, wipe the lens with a clean, damp cloth. If this is not sufficient, use a mild soap or a liquid cleaner. Do not use an abrasive, strong alkaline, or acid cleaner. Damage may result.
- Visually check for undue heating evidenced by discoloration of wires or other components, damaged parts or leakage evidenced by water or corrosion in the interior. Replace all worn, damaged or malfunctioning components and clean gasket seals before putting the luminaire back into service.
- Electrically check to make sure that all connections are clean and tight.
- Mechanically check that all parts are properly assembled.

## REPLACEMENT PARTS

Eaton's Crouse-Hinds Business LED Floodlights are designed to provide years of reliable lighting performance. However, should the need for replacement parts arise, they are available through your authorized Crouse-Hinds distributor. Assistance may also be obtained through your local Crouse-Hinds representative or the Crouse-Hinds Sales Service Department, 1201 Wolf Street, Syracuse, New York 13208, Phone 866-764-5454.

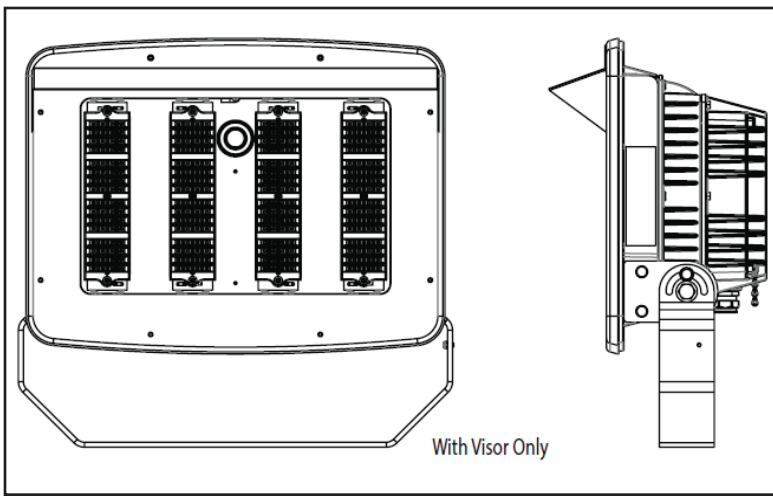

### VISOR INSTALLATION INSTRUCTIONS

1. Remove power from floodlight.
2. Place floodlight face up.
3. Carefully align visor with two (2) screw holes at the top of the fixture shown in the image above.
4. Install screws provided with visor, taking care to not scratch the finish of the floodlight. Torque to 80 in.-lbs. (9.0 N-m).
5. Install floodlight per above instructions.

**NOTE:** Visor can be installed before or after floodlight has been in operation.

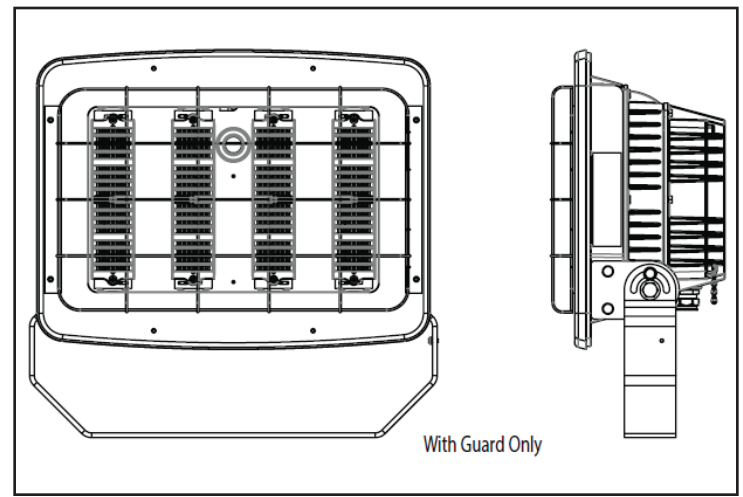

### GUARD INSTALLATION INSTRUCTIONS

1. Remove power from floodlight.
2. Place floodlight face up.
3. Carefully align guard with four (4) screw holes on each side of the fixture shown in the image above.
4. Install screws provided with guard, taking care to not scratch the finish of the floodlight. Torque to 80 in.-lbs. (9.0 N-m).
5. Install floodlight per above instructions.

**NOTE:** Guard can be installed before or after floodlight has been in operation.

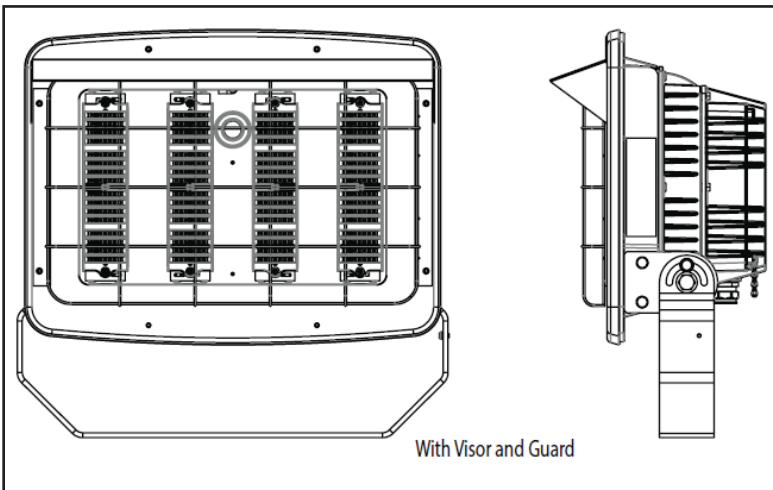

**NOTE:** Visor and guard can both be used on a floodlight at the same time. Visor and guard are always installed in the field and are not factory installed.

*All statements, technical information and recommendations contained herein are based on information and tests we believe to be reliable. The accuracy or completeness thereof are not guaranteed. In accordance with Crouse-Hinds "Terms and Conditions of Sale," and since conditions of use are outside our control, the purchaser should determine the suitability of the product for his intended use and assumes all risk and liability whatsoever in connection therewith.*