

EVL PFB Low Profile

Hazard-Gard® Auxiliary Lighting

Installation & Maintenance Information

SAVE THESE INSTRUCTIONS FOR FUTURE REFERENCE

APPLICATION

Low Profile HAZARD-GARD® auxiliary lighting fixtures are UL listed for use in Class I, Division 1 & 2, Groups B (with GB suffix), C, D, Class II, E, F & G, simultaneous presence, Class III, and Wet locations as defined by the National Electrical Code®. Refer to the fixture nameplate for specific classifications information and operating temperature (T) rating.

Low Profile HAZARD-GARD Fluorescent fixtures are supplied with a choice of voltages (120 and 277) and wattages (52 or 64). The 52 watt fluorescent fixture is also available in 220-240V, 50/60 Hz.

Low Profile HAZARD-GARD Fluorescent lighting fixtures are suitable for operation in ambient temperatures (as measured at mounting position) between 0°C (32°F) and 40°C (104°F), as marked on the fixture nameplate.

The EVLPFB fixture is supplied with a battery back-up. When AC power is interrupted, the fixture switches to a built-in battery power supply to light one lamp, providing auxiliary lighting for at least 90 minutes. When AC power is restored, the fixture automatically switches from battery power to AC power. While operating on AC power, the fixture circuitry recharges the battery.



1. Do not use this equipment for other than intended use.
2. The use of accessory equipment not recommended by the manufacturer may cause an unsafe condition.
3. Electrical power must be turned OFF before and during installation and maintenance.
4. Equipment should be mounted in locations and at heights where it will not readily be subject to tampering by unauthorized personnel.
5. Do not mount near gas or electric heaters.
6. Install and seal all equipment in accordance with the National Electrical Code articles pertaining to Hazardous (Classified) Locations plus any other codes.
7. Install only grounded wiring systems to supply the EVLPFB light fixture.
8. If possible, free installation area of hazardous atmospheres before wiring to reduce the risk of accidental explosion due to inadvertent shorting of battery during installation.
9. Observe all battery handling precautions contained herein.

INSTALLATION

Note: Low Profile HAZARD-GARD lighting fixtures should be installed, inspected, and maintained by qualified and competent personnel.

⚠ WARNING

- To avoid electrical shock, be certain that power is OFF before and during installation or before attempting any maintenance
- To avoid explosion, do not install where marked operating temperatures exceed ignition temperatures of hazardous atmospheres.
- Operating the fixture in ambient temperatures above those indicated on fixture nameplate will result in globe temperature exceeding nameplate markings and will shorten life of internal components.
- To avoid excessive operating temperatures, fixture must be installed with lamp base up within 25 degrees of vertical position.
- To avoid light failure, proper field wiring as specified on fixture nameplate must be used.

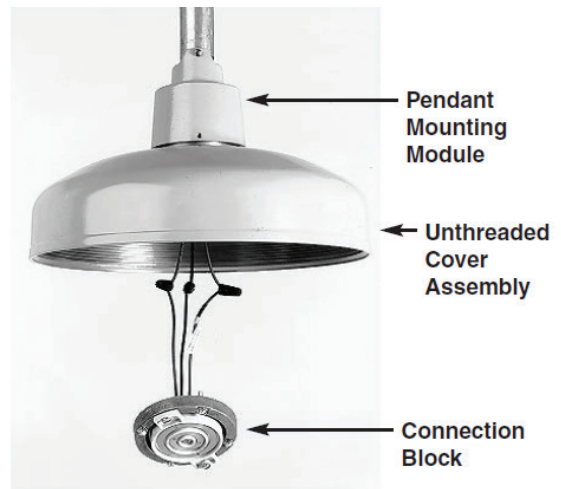

3. Apply a small amount of HTL® Lubricant to threads. Thread cover into module until mounting module seats firmly against O-ring seal

⚠ WARNING

- To maintain explosion proof integrity, make sure all threads are fully engaged.
- To prevent dangerous electrical shocks, fixture must be used with a grounded wiring system.

1. Install mounting module - pendant, ceiling, wall bracket, or stanchion in its support position and attach to conduit system. Secure with set screw, when provided. Pull wire in mounting position.
2. Remove cover from ballast housing and remove connection block from cover by unscrewing the four captive screws.

4. Connect connection block wires to field wiring following approved methods.
 - Install circuit grounding wire to green grounding screw near sealing well in connection block. Tighten green grounding screw securely.

Note: Install in accordance with National Electrical Code. Sections 250-78 and 501-16, utilizing an approved method of installation, to make sure electrical continuity is provided.

- Attach ungrounded primary field wire to BLACK conductor and other field wire to WHITE conductor.

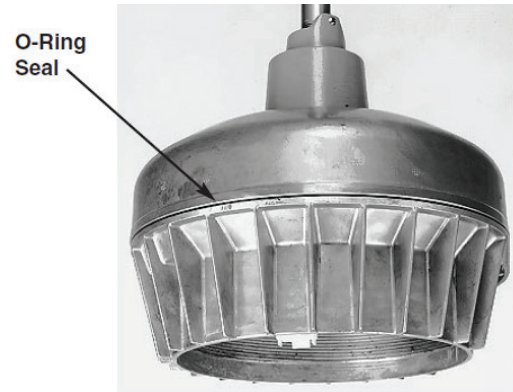
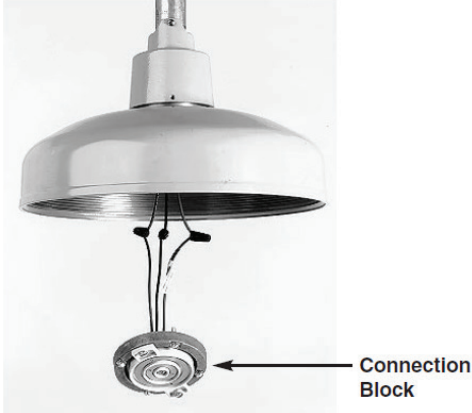

WARNING
To maintain explosion proof integrity, make sure all threads are fully engaged.

WARNING
To avoid light fixture failure and exceeding marked operating temperature use only lamp type and wattage specified on nameplate of fixture.

5. Connect the unswitched supply to RED conductor.

Note: Provide an unswitched AC power source for auxiliary ballast fed from the same branch circuit as the switched supply.

 - Connect the inverter plug and receptacle (white/black and white/red wires) in ballast housing. This is disconnected prior to installation to avoid discharging the batteries during shipment.
6. Insert connection block into cover and tighten four captive screws, as follows:
 - Push conductors back up into mounting module.
 - Seat connection blocks securely into cover.
 - Start all four captive screws into cover and tighten evenly.

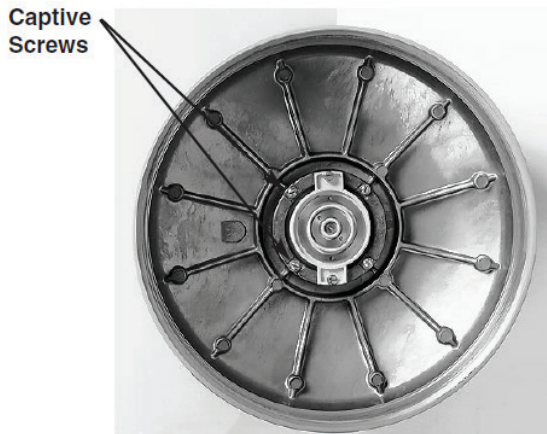

7. Loosen locking tab screw on housing and slide tab up out of the way. Unscrew globe assembly from ballast housing.
8. Apply a small amount of HTL Lubricant to threads. Rethread ballast housing onto cover assembly until cover assembly seats firmly against O-ring seal and secure with set screw.

9. Install lamp into lamp holder of ballast housing. Use only correct lamp as specified on the fixture nameplate.
10. Apply a small amount of HTL Lubricant to threads. Rethread globe/guard assembly on ballast housing until assembly seats firmly against O-ring seal. Slide locking tab into position, so it engages slot on globe assembly. Make sure to properly tighten screw to secure locking tab.

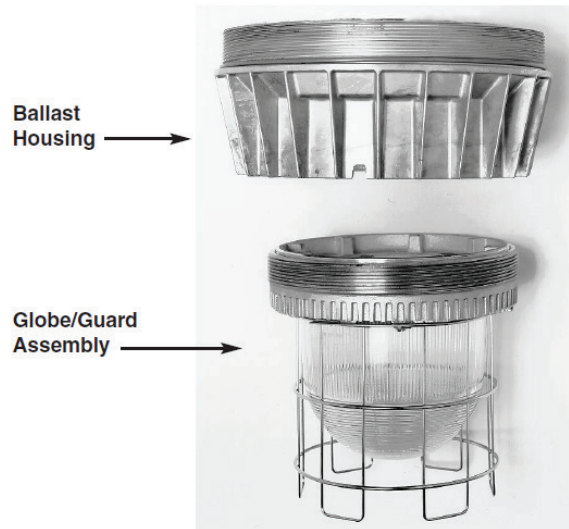

11. Install reflector, if provided.
12. Turn power on.

EVL PFB SERIES PUSH-TO-TEST SWITCH

An external push to test switch suitable for the classified area shall be wired in the supply circuit to test the EVL PFB Series battery back up. (See wiring diagram) Crouse-Hinds recommends a Crouse-Hinds EDS3192 for Class I Groups C, D or EFS3192 for Class I Group B applications.

REFLECTOR INSTALLATION

Optional Reflectors:

- 30° Angle RA739
- Dome RD739

Optional reflectors are attached to the Low Profile HAZARD- GARD fixtures as follows:

1. Place reflector in position on fixture lower housing. When correctly placed, all three tabs of reflector are located between reflector mounting plates.

Note: Angle reflector should be installed closest to final mounting position.

2. Rotate reflector clockwise so that the three tabs slide under captivating plates on housing.
3. Continue to rotate reflector clockwise until reflector tabs engage final captivating bosses and reflector “snaps” into position.
4. Adjust angle reflector to its final orientation by loosening set screws at mounting module joint and turning fixture clockwise. Make sure to retighten set screw.

REFLECTOR REMOVAL

The reflector can be removed by rotating it counterclockwise until the three reflector tabs are free of the captivating plates.

MAINTENANCE

1. Perform visual, electrical, and mechanical inspections on a regular basis and replace worn or damaged parts as necessary. This should be determined by the environment and frequency of use. However, it is recommended that checks be made at least once a year. We recommend an Electrical Preventive Maintenance Program as described in the National Fire Protection Association Bulletin NFPA No. 70B.
2. The globe and reflector should be cleaned periodically to insure continued lighting performance. To clean, wipe the reflector then the globe with a clean, damp, soft cloth. If this is not sufficient, use a mild soap or a liquid cleaner such as Collinite NCF or Duco #7. Do not use an abrasive, strong alkaline, or acid cleaner. Damage to the reflector may result.
3. Check slip ring on connection block for electrical continuity. Remove any surface contamination by lightly polishing contact ring(s). Carefully bend contacts up to form a 45° angle.

WARNING

- To avoid electrical shock and possible explosion while performing maintenance, electrical power must always be turned off and the area free of hazardous gas or vapors.
- To avoid burning your hands while performing maintenance, make sure globe and lamp are cool.

BATTERY PACK MAINTENANCE EVL PFB SERIES

WARNING

Fixture is supplied with battery back-up (EVL PFB) system, disconnect the inverter plug and receptacle located in the ballast housing before and during maintenance. This will disconnect the charged battery from the lamp receptacles.

CAUTION

All service and testing should be done by qualified personnel.

The battery back-up ballast must be checked periodically to insure that it is working properly. The following schedule is recommended.

1. Visually inspect the charging indicator light monthly. It should be illuminated at all times. This indicates that the battery is being charged. Test the auxiliary operation of the fixture, at this time, for a minimum of 30 seconds. This can be done by disconnecting the power to the fixture. One lamp should operate with reduced intensity.
2. Conduct a 90 minute discharge once a year. One lamp should operate at a reduced intensity for a least 90 minutes.

RELAMPING:

1. Disconnect power to fixture and allow unit to cool completely.
2. Loosen screw that secures locking tab. Lower tab and retighten screw to hold locking tab temporarily out of the way.
3. Unscrew globe/guard assembly and remove old lamps.
4. Install new lamps with identical type lamp as marked on fixture nameplate.
5. Thoroughly clean or replace O-ring seal.
6. Apply a small amount of HTL Lubricant to threads. Rethread globe/guard assembly onto ballast housing until assembly seats firmly against O-ring seal. Secure with locking tab, making sure tab engages slot on globe assembly.

CAUTION

Verify that all replacement lamp types marked on the installed luminaire are also identified as suitable for use with the backup battery pack.

WIRING DIAGRAM

EVLPFB 52 and 64 Watt (120 OR 277V)

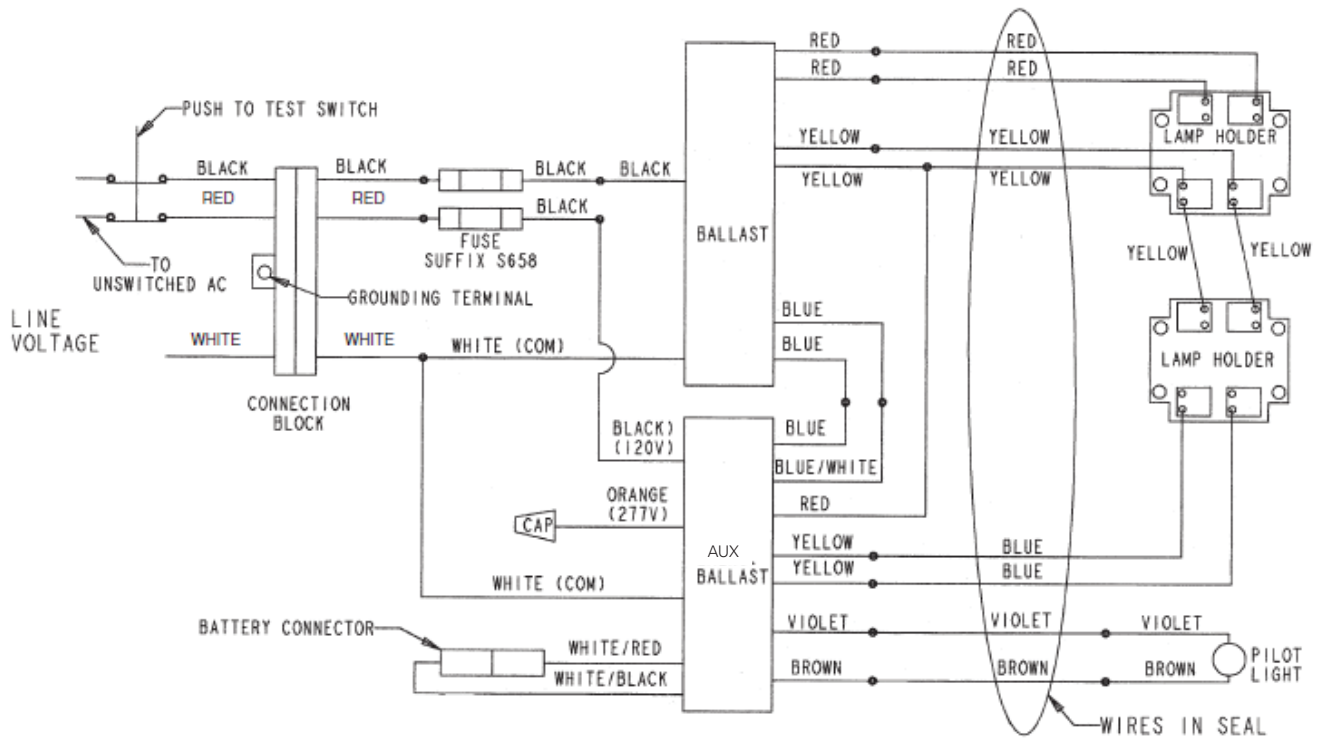

All statements, technical information and recommendations contained herein are based on information and tests we believe to be reliable. The accuracy or completeness thereof are not guaranteed. In accordance with Crouse-Hinds "Terms and Conditions of Sale", and since conditions of use are outside our control, the purchaser should determine the suitability of the product for his intended use and assumes all risk and liability whatsoever in connection therewith.