

Pro-Flood LED Floodlight

PFM Series 25L Industrial LED Floodlight

Installation & Maintenance Information

SAVE THESE INSTRUCTIONS FOR FUTURE REFERENCE

APPLICATION

Pro-Flood LED Floodlights construction is designed for use indoors and outdoors in marine and wet locations, where moisture, dirt, corrosion, vibration and rough usage may be present.

- UL1598 Luminares, UL1598A Marine, UL8750
- Wet Locations, NEMA 4X
- IP66
- cUL

Pro-Flood LED Floodlights are supplied for use with a choice of voltages:

- 100VAC – 277VAC, 50/60Hz and 127VDC – 250VDC
- 277VAC - 480VAC, 50/60Hz

⚠ WARNING

To avoid the risk of fire, explosion, or electric shock, this product should be installed, inspected, and maintained by a qualified electrician only, in accordance with all applicable electrical codes.

⚠ WARNING

To avoid electric shock:

Be certain electrical power is OFF before and during installation and maintenance.

To avoid burning hands:

Make sure lens and lamp are cool when performing maintenance.

⚠ WARNING

To avoid potentially unsafe operating conditions:

Make sure the supply voltage is within the floodlight voltage range stated on the nameplate.

Do not operate in ambient temperatures above those indicated on the floodlight nameplate.

Use only replacement parts from Cooper Crouse-Hinds.

Use proper supply wiring as specified on the floodlight nameplate.

All gasket seals must be clean.

Before opening, electrical power to the floodlight must be turned off. Keep tightly closed when in operation.

Do not position the floodlight beyond the aiming range limits.

Do not exceed the maximum allowable current draw of 15 Amps when daisy chaining floodlights, (S886 configuration only).

- Using the floodlight yoke as a template, mark and drill desired location on mounting surface.
- Secure floodlight yoke to mounting surface by applying proper torque to corrosion resistant 1/2 in bolts or lag screws accompanied by lock washers.
- Ensure that the safety chain is securely fastened between the yoke bracket and back cover.

WIRING

Wiring the Floodlight

- All components in the fixture are prewired so only line in, neutral, and ground need to be connected in the fixture to the terminals per the wiring diagrams using methods that comply with all applicable codes. Use supply cord with outer sheath diameter in accordance with Table 1. Terminate the equipment grounding conductor (green) first, the common (white) next, and finally, the line voltage (black) last. Secure all electrical connections.

Table 1

Gland Name	PFM25L Ordering Suffix	Thread Type	Cable Diameter Range
NCG75-75	S886	3/4 in NPT	0.35 - 0.75 in (8.9 - 19.0 mm)
CAP816604	M20	M20 x 1.5	8.5 - 16.0 mm (0.34 - 0.62 in)
CAP816794	M25	M25 x 1.5	8.5 - 16.0 mm (0.34 - 0.62 in)

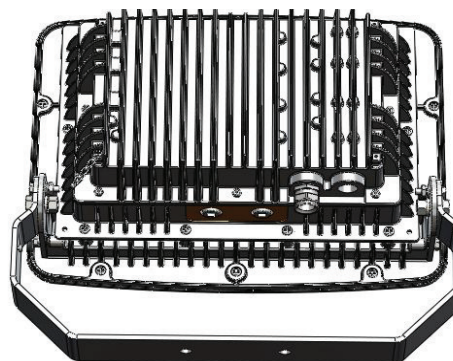

Figure 1

INSTALLATION

Mounting

Yoke Mount - Post Mount Using Floodlight Yoke Only

- Select a durable, corrosion resistant mounting surface capable of supporting the fixture's 50 lb (22.7 kg) weight and cantilevered mass (as applicable).

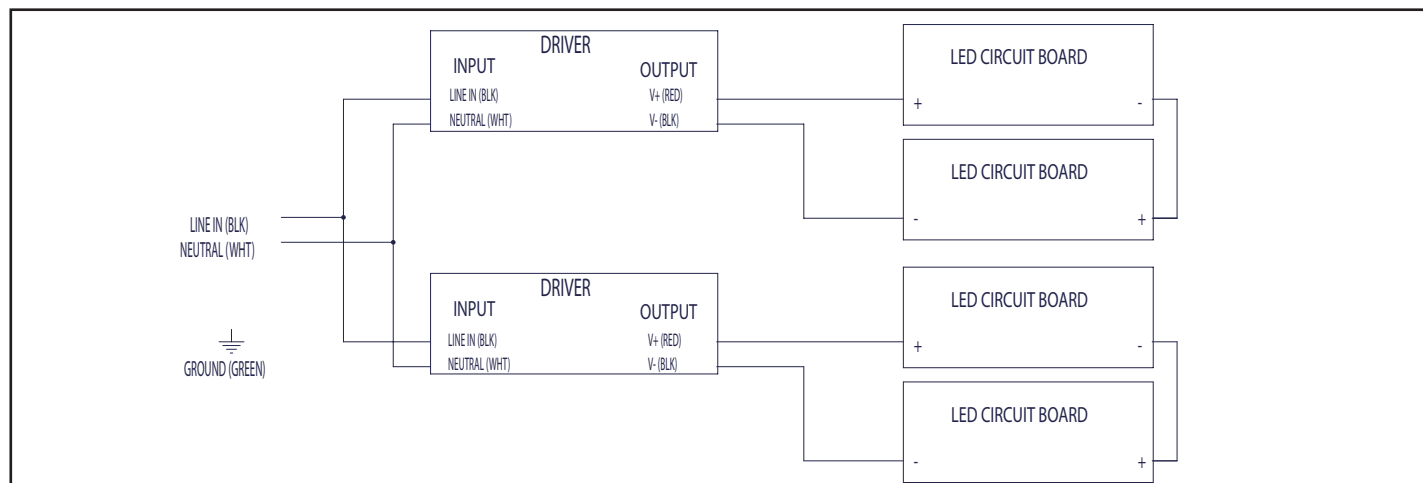

Figure 2 - Wiring Diagram

2. Re-install the back panel and tighten all eight (8) panel mounting screws to 80 in-lbs (9.0 N-m).

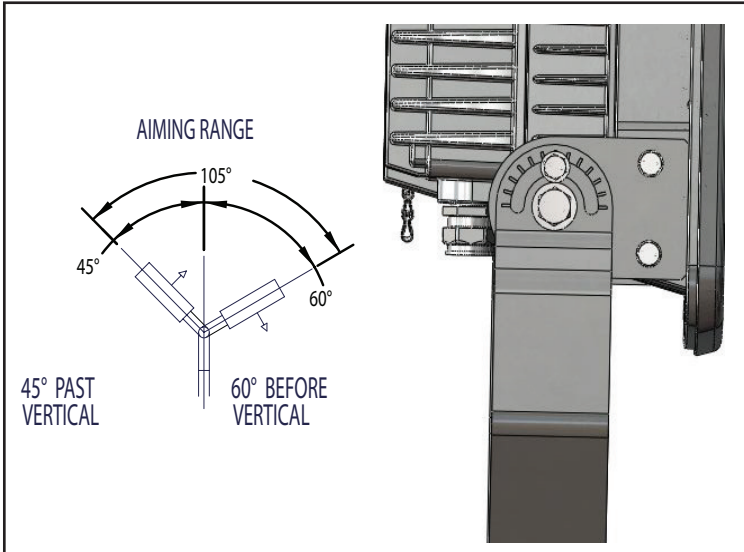

Figure 3

3. To make final vertical adjustment, loosen the pivot bolts on the floodlight yoke to position floodlight at the desired angle (limited to 60 degrees forward and 45 degrees back).
4. Rotate the floodlight housing to the desired position.
5. Tighten the two 1/2"-13 bolts to 45 ft-lbs (61.0 N-m). Tighten the 5/16"-18 bolts in the adjustment slots to 12 ft-lbs (16.3 N-m).
6. Turn power on.

MAINTENANCE

- Perform visual, electrical, and mechanical inspections on a regular basis. The environment and frequency of use should determine this. However, it is recommended that checks be made at least once a year. We recommend an Electrical Preventive Maintenance Program as described in the National Fire Protection Association Bulletin NFPA 70B: Recommended Practice for Electrical Equipment Maintenance (www.nfpa.org).
- The lens should be cleaned periodically to ensure continued lighting performance. To clean, wipe the lens with a clean damp cloth. If this is not sufficient, use a mild soap or a liquid cleaner. Do not use an abrasive, strong alkaline, or acid cleaner. Damage may result.
- Visually check for undue heating evidenced by discoloration of wires or other components, damaged parts, or leakage evidenced by water or corrosion in the interior. Replace all worn, damaged, or malfunctioning components and clean gasket seals before putting the luminaire back into service.
- Electrically check to make sure that all connections are clean and tight.
- Mechanically check that all parts are properly assembled.

REPLACEMENT PARTS

Cooper Crouse-Hinds Pro-Flood LED Floodlights are designed to provide years of reliable lighting performance. However, should the need for replacement parts arise, they are available through your authorized Cooper Crouse-Hinds distributor. Assistance may also be obtained through your local Cooper Crouse-Hinds representative or the Cooper Crouse-Hinds Sales Service Department, P.O. Box 4999, Syracuse, New York 13221, Phone 866-764-5454.

DIMENSIONS

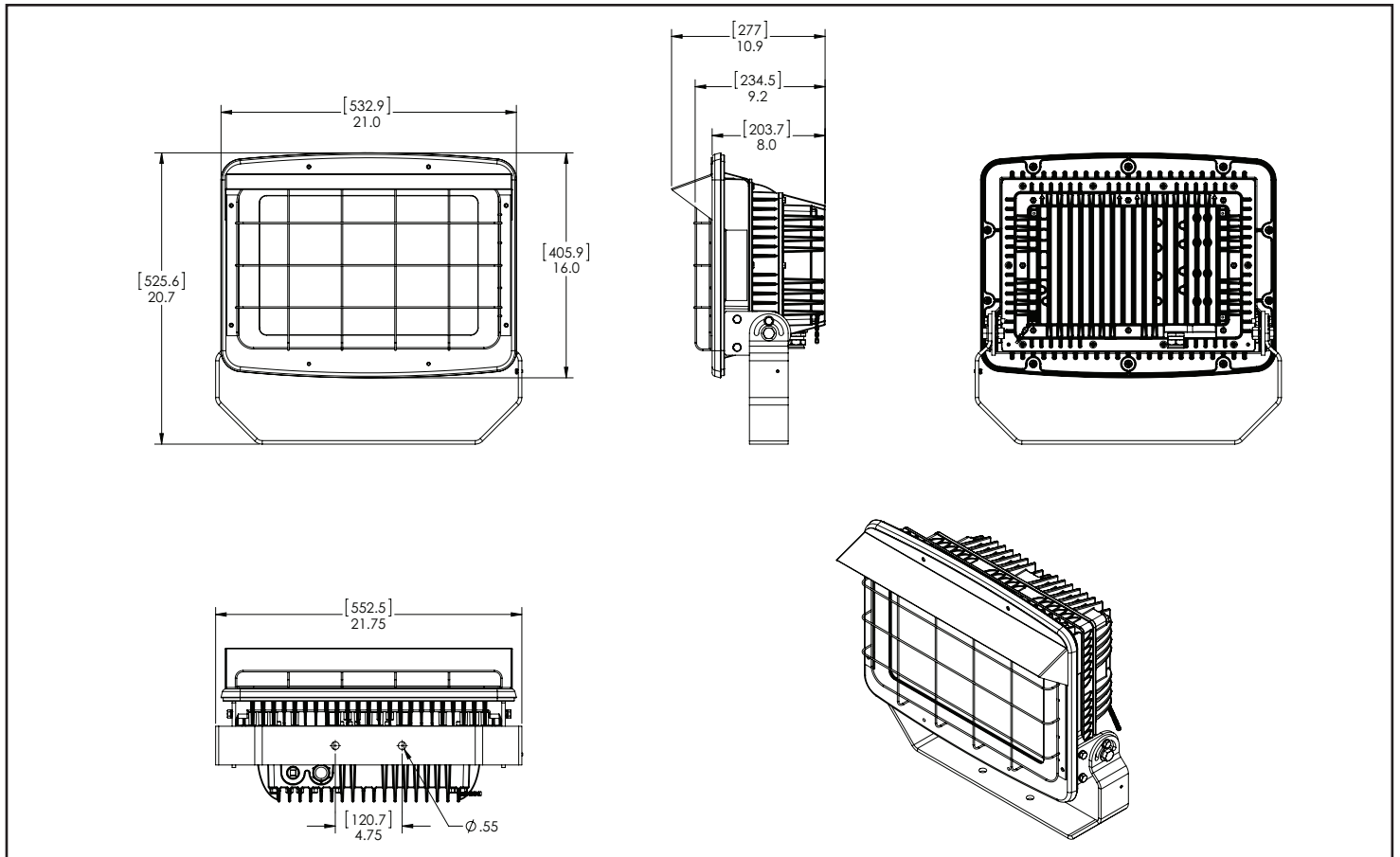
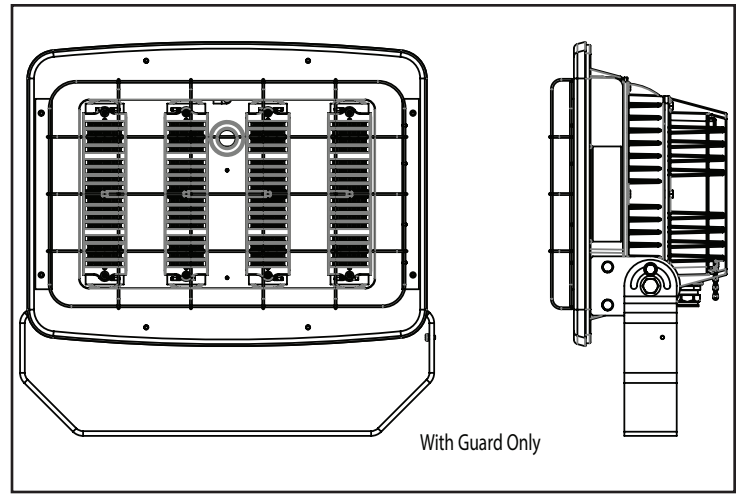
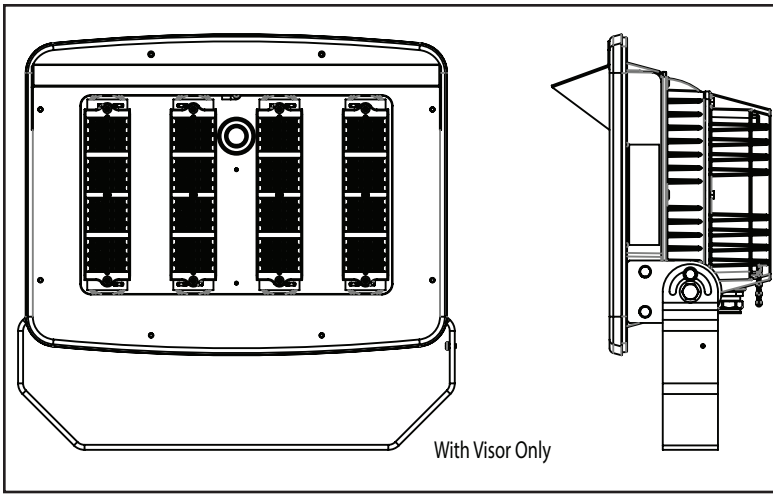

Figure 4



VISOR INSTALLATION INSTRUCTIONS

1. Remove power from floodlight.
2. Place floodlight face up.
3. Carefully align visor with two (2) screw holes at the top of the fixture shown in the image above.
4. Install screws provided with visor, taking care to not scratch the finish of the floodlight. Torque to 80 in-lbs (9.0 N-m).
5. Install floodlight per above instructions.

NOTE: Visor can be installed before or after floodlight has been in operation.

GUARD INSTALLATION INSTRUCTIONS

1. Remove power from floodlight.
2. Place floodlight face up.
3. Carefully align guard with four (4) screw holes on each side of the fixture shown in the image above.
4. Install screws provided with guard taking care to not scratch the finish of the floodlight. Torque to 80 in-lbs (9.0 N-m).
5. Install floodlight per above instructions.

NOTE: Guard can be installed before or after floodlight has been in operation.

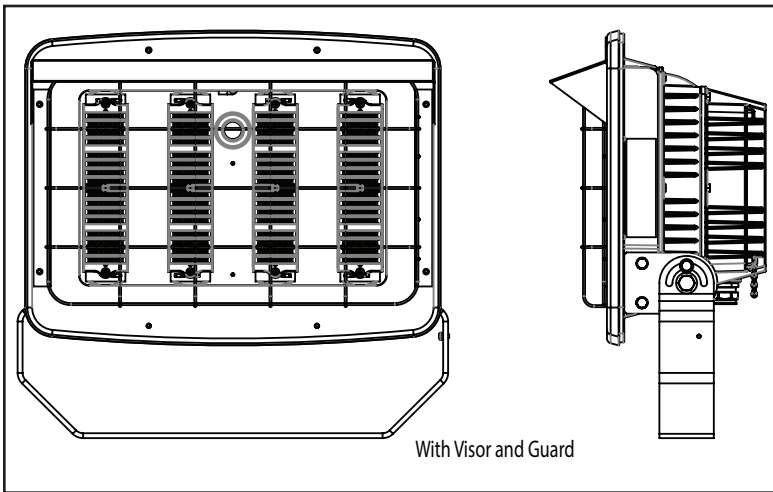

NOTE: Visor and guard can both be used on a floodlight at the same time. Visor and guard are always installed in the field and are not factory installed.

All statements, technical information and recommendations contained herein are based on information and tests we believe to be reliable. The accuracy or completeness thereof are not guaranteed. In accordance with Cooper Crouse-Hinds "Terms and Conditions of Sale," and since conditions of use are outside our control, the purchaser should determine the suitability of the product for his intended use and assumes all risk and liability whatsoever in connection therewith.