

Champ® Voyager nR Series Stainless Steel HID Floodlight 150 - 400 Watts

Installation & Maintenance Information

SAVE THESE INSTRUCTIONS FOR FUTURE REFERENCE

APPLICATION

Champ® Voyager nR Series stainless steel floodlights are suitable for use in the following hazardous (classified) locations as defined by the National Electrical Code (NEC®), Canadian Electrical Code (CEC), and International Electrotechnical Commission (IEC):

- Class I Division 2, Groups A, B, C, D; Class I Zone 2 II
- Class I Zone 2, AEx nR, (AEx nA nR with outlet box) Group IIC

The 1996 NEC included the addition of article 505 adopting the IEC "Zone method" as an alternative means of classifying Class I locations. Article 505 allows the use of IEC type explosion protection equipment in North America.

Type "n" protection is defined in IEC 60079-15 as "A type of protection applied to electrical apparatus such that, in normal operation, the electrical apparatus is not capable of igniting a surrounding explosive gas atmosphere and a fault capable of causing ignition is not likely to occur."

This luminaire is a restricted breathing product. Restricted breathing, identified by the marking "Ex nR" (AEx nR in the US) means that an enclosure is sufficiently well sealed to limit the entry of flammable gas to

below explosive concentration.

The Champ® Voyager nR Series floodlight comes standard as a "restricted breathing" luminaire. That means it restricts vapors and gases from entering inside the luminaire. Therefore, please retain and use the sealing cord connector (located on the bottom right corner of the luminaire) with 16-3 type SOW or equal cord.

Refer to the floodlight nameplate for specific classification information, maximum ambient temperature suitability and corresponding operating temperature (T-Number).

Champ® Voyager nR Series stainless steel floodlight Type 4X / IP66 construction is designed for use indoors and outdoors in Marine and Wet locations, where moisture, dirt, corrosion, vibration and rough usage may be present.

Champ® Voyager nR Series stainless steel floodlights are supplied for use with a choice of voltages (120, 208, 220, 240, 277, 480, tri-tap, multi-tap, etc.) and light sources, High Pressure Sodium (HPS), Metal Halide (MH), in ratings of 150 through 400 watts.

⚠ WARNING

To avoid the risk of fire, explosion, or electric shock, this product should be installed, inspected, and maintained by a qualified electrician only, in accordance with all applicable electrical codes.

⚠ WARNING

To avoid electric shock:

Be certain electrical power is OFF before and during installation and maintenance.

Floodlight must be supplied by a wiring system with an equipment grounding conductor.

To avoid burning hands:

Be sure line power to the ballast assembly is OFF for at least 15 minutes to allow the capacitor to discharge.

Make sure lens and lamp are cool when performing maintenance.

⚠ WARNING

To avoid explosion:

Make sure the supply voltage is the same as the floodlight voltage.

Do not install where the marked operating temperatures exceed the ignition temperature of the hazardous atmosphere.

Do not operate in ambient temperatures above those indicated on the floodlight nameplate.

Do not position the floodlight beyond the aiming range limits depicted on page 4.

Use only the lamp and wattage specified on the floodlight nameplate.

Use proper supply wiring as specified on the floodlight nameplate.

All gasket seals must be clean.

Before opening, electrical power to the floodlight must be turned off. Keep tightly closed when in operation.

To maintain restricted breathing properties, do not substitute cable fitting supplied with fixture.

INSTALLATION

Mounting

A) Pole Mount with SFA6 Slipfitter

Note: For Class I, Zone 2 refer to NEC 505.15(c).

1. Using the ½" bolts, nuts and lock washers provided, securely fasten the floodlight yoke to the flange on the SFA6 slipfitter. Refer to Figure 1 for slipfitter dimensions. Torque the bolts to 45 lbs-ft.

NOTE: Angular positioning of the floodlight will be done later.

2. Place the SFA6 slipfitter adapter with the secured floodlight onto the 2" Pole top tenon.
3. Secure by tightening the slipfitter base bolts. Torque base bolts to 19 lbs-ft.

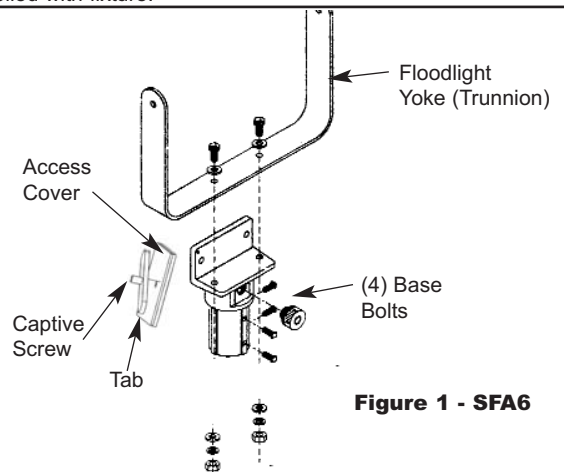

Figure 1 - SFA6

B) Wall Bracket Mount - Wall Mount Using SWB6 Wall Mount Bracket and SFA6 Slipfitter

1. Determine the mounting location of the SWB6 bracket using the bolt hole pattern shown in Figure 2.
2. Mount the SWB6 bracket (with elbow pointing up) using four (4) ½" bolts or lag screws (not provided) or by welding in position.
3. Using the ½" bolts, nuts and lock washers provided, securely fasten the floodlight yoke to the flange on the SFA6 slipfitter. Refer to Figure 1 for slipfitter dimensions. Torque the bolts to 45 lbs-ft.
4. Position the SFA6 Slipfitter onto the SWB6 bracket.
5. Secure by tightening the slipfitter base bolts. Torque base bolts to 19 lbs-ft.

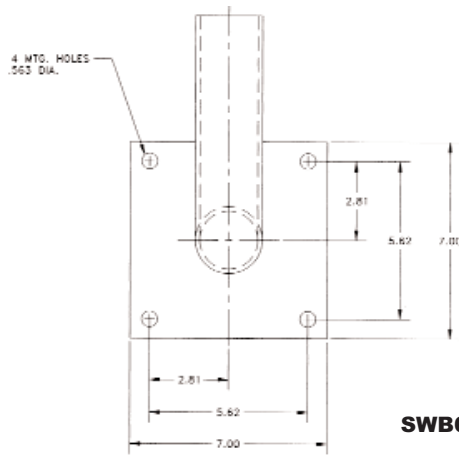

Figure 2 - SWB6 Bolt Hole Pattern

C) Yoke (Trunnion) Mount - Wall Mount Using Floodlight Yoke Only

1. Using trunnion arm as a template, mark and drill desired location on mounting surface.
2. Secure trunnion mounting arm to surface using ½" bolts or lag screws (not provided).

WIRING

A) Pole Mount with SFA6 Slipfitter

IMPORTANT !

Under no circumstances may wire splices be used in the slipfitter or pole. Use continuous length supply cord from fixture to approved customer supplied wiring chamber.

Note: For Class 1, Zone 2 refer to NEC 505.15(c) or 501.10(b). Wiring must be installed in accordance with NEC 400.14.

1. For SFA6 Slipfitter Adapter: Remove the access cover by loosening the captive screw to disengage the locking tab. Set aside for reassembly later.
2. Using access opening pull #16-3 type SO cord (or other extra hard usage portable cord) supply wire from customer supplied wire chamber through pole. Using the CGB294 cable connector provided, position a minimum overall length of 3 ft. cord for final connection to light fixture. Use a small amount of HTL thread lubricant when installing cord connector and install according to instructions supplied with connector. Securely tighten cord

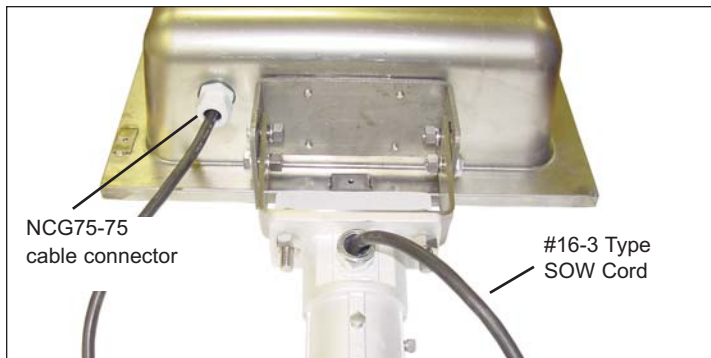

Figure 3 - Pole Mount with SFA6 Slipfitter

connector into slipfitter.

3. Strip cord insulation jacket back 3 inches and strip each conductor 3/8".
4. Secure the access cover as follows: For SFA 6 slipfitter secure cover by tightening the captive screw to engage locking tab. For SFA6 SS slipfitter attach access plate with four (4) screws and lock washers.

Proceed to C) Wiring the Floodlight on the next page.

B) Wall Mount with or Without SWB6 Wall Mount Bracket and SFA6 Slipfitter

1. When using the SWB6 wall bracket and SFA6 slipfitter, plug the ¾ NPT entry on the SFA6 slipfitter with Crouse-Hinds plug PLG2 (not supplied).
2. To make the required wiring transition to portable cord, use any UL listed outlet box and cover suitable for wet locations. See Figure 4. Wall mount the outlet box adjacent to the floodlight yoke or SWB6 wall mount bracket if used.
3. Install one end of a length of #16-3 type SOW portable cord (or

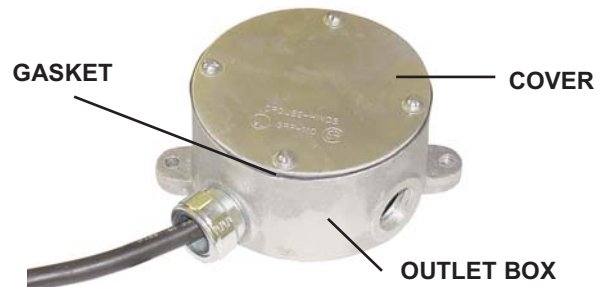

Figure 4

other extra hard usage portable cord) into the outlet box using a Crouse-Hinds NCG75-75 cable connector. See Figure 5. The cord length required will allow ample slack to adjust the aiming angle of the floodlight.

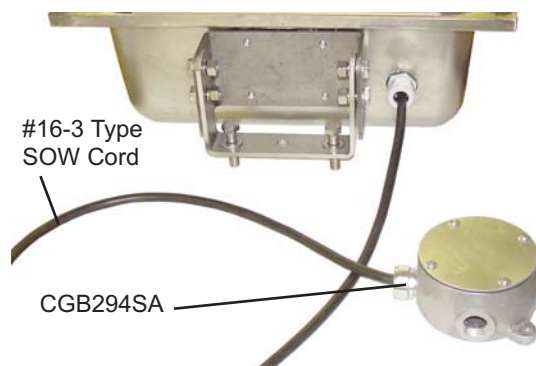

Figure 5 - Wall Mount with Outlet Box

4. Proceed to C) Wiring the Floodlight.

C) Wiring the Floodlight

1. Loosen the 7 captive floodlight cover screws on the door and completely open the cover. Remove the 3 screws that secure the cover plate over the ballast housing. Be sure to retain the screws in a safe place.
2. Ensure that line power is not connected to the SOW cord. Be sure to strip the wires of the SOW cord for termination. Notice that all components in the ballast assembly area are prewired. You will only need to wire line power to the terminal block and ground wire. See Figure 6.

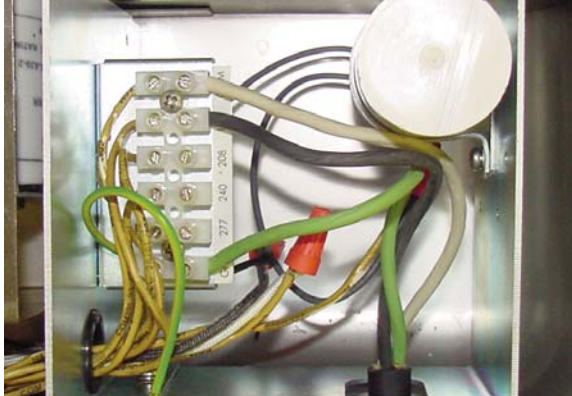

Figure 6 - Prewired Components

3. Loosen the screws on the terminal block for the appropriate line voltage, ground (GND) and common (COM) connections. Run the SOW cord through the sealing cord connector, which is the connector on the bottom right of the luminaire. Terminate the equipment grounding conductor (green) of the SOW cord first, the common (usually white) and finally the line voltage (usually black) to the marked terminal blocks.
4. Tighten the sealing cord connector around the SO cord so that the cord is held securely in place. Place the ballast assembly cover back over the ballast assembly area and fasten in place with the three screws.

⚠ WARNING

To avoid explosion: On ballasts with multiple supply voltage taps (MT, TT, MV, etc), all unused leads must terminate at the terminal block or be capped with closed end wire connectors.

5. Install the lamp as specified on the nameplate. See LAMP INSTALLATION AND REPLACEMENT section.
6. Close floodlight cover door making sure that all wires are safely inside and positioned away from the ballast area. Securely tighten all cover screws. For proper gasket seal, torque the cover screws to 14-22 lbs-in.
7. To make final vertical adjustment, loosen the two pivot bolts on the floodlight yoke to position floodlight at the desired angle (within the acceptable aiming range limits). See Figure 7. Tighten the two pivot bolts to 45 lbs-in.

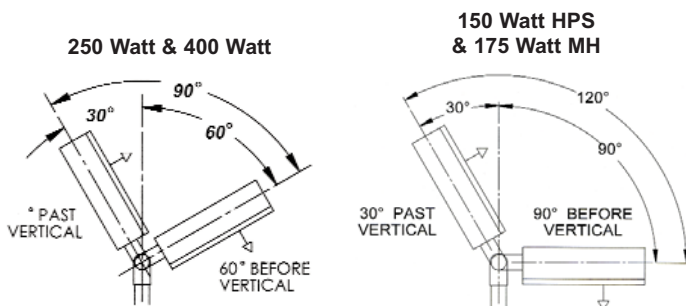

Figure 7 - Final Vertical Adjustment

⚠ WARNING

To avoid ignition of the hazardous atmospheres or overheating of the floodlight:

Do not position the floodlight beyond the aiming range limits.

8. To make the final horizontal (radial) adjustment, loosen the four (4) slipfitter base bolts.
9. Rotate the floodlight housing to the desired position.
10. Tighten the slipfitter base bolts to 19 lbs-in to lock in position.
11. Turn power on.

LAMP INSTALLATION & REPLACEMENT

1. Note both vertical and radial aiming angles. If these are disturbed during relamping they should be readjusted after relamping.
2. Disconnect power to the floodlight and allow to cool completely. Allow the capacitor to discharge for 15 minutes.
3. Completely loosen the 7 captive cover screws and swing open the cover. See Figure 8.



Figure 8 - Swing Open Cover

4. Remove lamp.
5. Perform cleaning and inspection as noted in the MAINTENANCE section.
6. Screw new lamp into lampholder and securely tighten lamp. New lamp must be identical type, size and wattage as marked on the floodlight nameplate.

⚠ CAUTION

To prevent ballast damage on high pressure sodium floodlights, replace burned out lamps as soon as possible.

To avoid shortened lamp life, lampholder failure, wiring faults or ballast failure, tighten lamp firmly and completely.

To avoid injury, guard against lamp breakage.

7. Thoroughly clean lens and cover gasket seal with a clean damp cloth. If this is not sufficient, use a mild soap or a liquid cleaner such as Collinite NCF or Duco #7. Do not use an abrasive, strong alkaline, or acid cleaner. Damage may result.
8. Close floodlight cover door making sure that all wires are safely inside and positioned away from the ballast area. Securely tighten all cover screws. For proper gasket seal, torque the cover screws to 14-22 lbs-in.

MAINTENANCE

- Perform visual, electrical and mechanical inspections on a regular basis. The environment and frequency of use should determine this. However it is recommended that checks be made at least once a year. We recommend an Electrical Preventive Maintenance Program as described in the National Fire Protection Association Bulletin NFPA 70B: Recommended Practice for Electrical Equipment Maintenance (www.nfpa.org)
- The lens should be cleaned periodically to insure continued lighting performance. To clean, wipe the reflector, then the lens with a clean damp cloth. If this is not sufficient, use a mild soap or a liquid cleaner such as Collinite NCF or Duco #7. Do not use an abrasive, strong alkaline, or acid cleaner. Damage may result.
- Visually check for undue heating evidenced by discoloration of wires or other components, damaged parts, or leakage evidenced by water or corrosion in the interior. Replace all worn, damaged or malfunctioning components and clean gasket seals before putting the luminaire back into service.

- Electrically check to make sure that all connections are clean and tight.
- Mechanically check that all parts are properly assembled.

REPLACEMENT PARTS

Cooper Crouse-Hinds Champ® Voyager nR Series stainless steel floodlights are designed to provide years of reliable lighting performance. However, should the need for replacement parts arise, they are available through your authorized Cooper Crouse-Hinds distributor. Assistance may also be obtained through your local Cooper Crouse-Hinds representative or the Cooper Crouse-Hinds Sales Service Department, P.O. Box 4999, Syracuse, New York 13221, Phone 315/477-7000.

WIRING DIAGRAMS

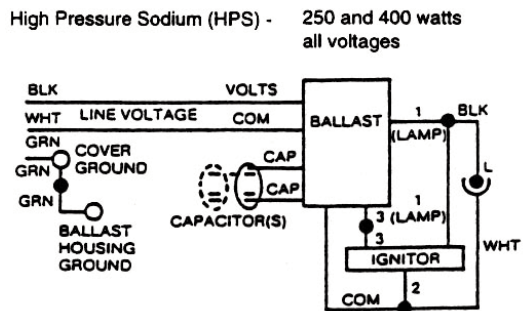
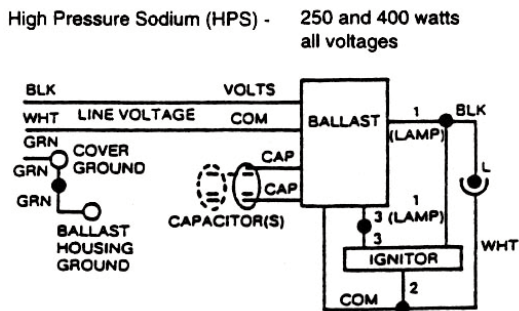
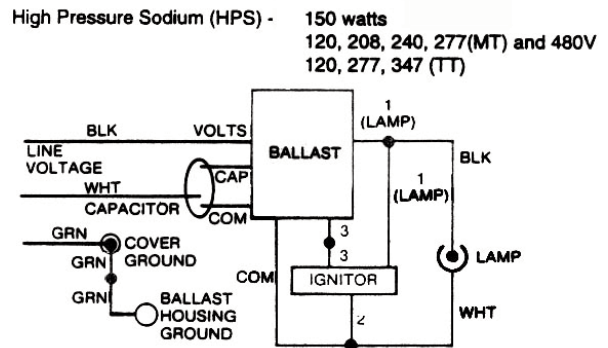
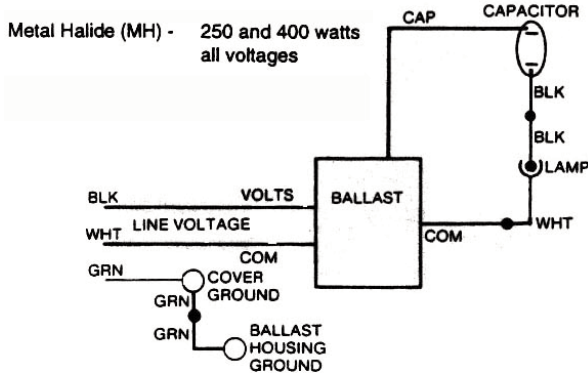

All statements, technical information and recommendations contained herein are based on information and tests we believe to be reliable. The accuracy or completeness thereof are not guaranteed. In accordance with Cooper Crouse-Hinds "Terms and Conditions of Sale", and since conditions of use are outside our control, the purchaser should determine the suitability of the product for his intended use and assumes all risk and liability whatsoever in connection therewith.