

FZD Series Floodlight 150 - 400 Watts

Installation & Maintenance Information

COOPER Crouse-Hinds
IF 1438

SAVE THESE INSTRUCTIONS FOR FUTURE REFERENCE

APPLICATION

FZD Series Floodlights are suitable for use in the following hazardous (classified) areas as defined by the National Electrical Code® (NEC) and Canadian Electrical Code (CEC):

- Class I, Division 1, Groups C and D;
- Class I, Zone 1 Group IIB

Refer to the nameplate for specific classification information, maximum ambient temperature suitability and corresponding operating temperature (T-Number).

FZD Series Floodlights have NEMA 4X / IP66 construction and are designed for use indoors and outdoors in marine and wet locations, where moisture, dirt, corrosion, vibration and rough usage may be present.



FZD Series Floodlights are supplied with a choice of voltages (120, 208, 220, 240, 277, 480, tri-tap, multi-tap, etc.) and light sources (High Pressure Sodium (HPS) or Metal Halide (MH)), in ratings of 150 through 400 watts.

WARNING

To avoid the risk of fire, explosion, or electric shock, this product should be installed, inspected, and maintained by a qualified electrician only, in accordance with all applicable electrical codes.

WARNING

To avoid electric shock:

Be certain electrical power is OFF before and during installation and maintenance.

Floodlight must be supplied by a wiring system with an equipment grounding conductor.

To avoid burning hands:

Make sure lamp tube and lamp are cool when performing maintenance.

WARNING

To avoid explosion:

Make sure the supply voltage is the same as the floodlight voltage.

Do not install where the marked operating temperatures exceed the ignition temperature of the hazardous atmosphere.

Do not operate in ambient temperatures above those indicated on the floodlight nameplate.

Seal all conduit entries within 5 feet; seal must be installed on fixture side of ECLK or ECGJH flexible coupling.

Use only the lamp and wattage specified on the floodlight nameplate.

Use proper supply wiring as specified on the floodlight nameplate.

All gasket seals must be clean.

Before opening, electrical power to the floodlight must be turned off. Keep tightly closed when in operation.

DIMENSIONS (Inches)

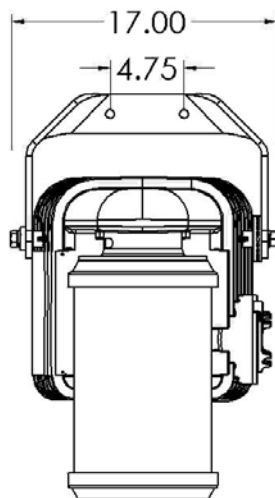

Weight: 85 lbs. max

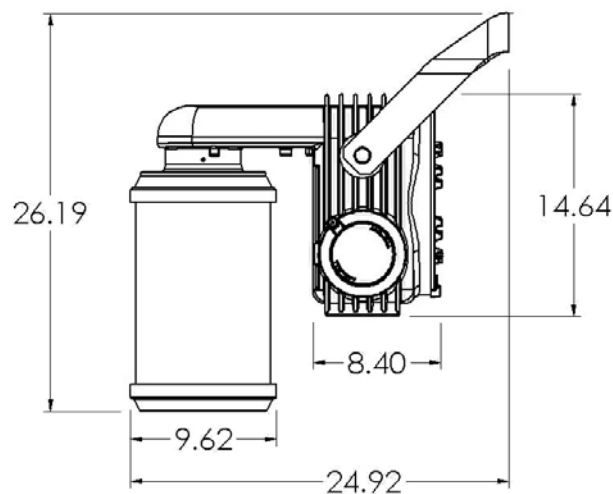

INSTALLATION

Supply Voltage

FZD floodlights with multi-tap or tri-tap ballasts are pre-wired at the factory for 277 volts (MT) or 347 volts (TT). If supply voltage is different than pre-wired value, ballast must be re-wired before mounting.

To rewire supply voltage, follow these steps:

1. Remove large ballast cover on the back of the floodlight for access to ballast.
2. Remove wire nut from 277 or 347 volt ballast line and line going through wire seal. (see wiring diagram on pg. 4).
3. Re-wire wire seal line to desired volt line.
4. Replace wire nut to cap off 277 volt or 347 volt line.
5. Reassemble ballast cover and hand tighten securely.

Mounting

Pole Mounting - SFA6-XP required. Order separately.

For pole mounting on 2" NPT conduit used as a pole, use the Cooper Crouse-Hinds pole mount adapter attachment (Cat. No. SFA6-XP).

1. Install the SFA6-XP pole mount adapter. Refer to the instructions supplied with the SFA6-XP pole mount adapter.
2. Securely fasten the floodlight trunnion (yoke) bracket to the slipfitter using the 1/2" bolts provided. Tighten bolts to 70 ft. lbs. torque.

Trunnion Mounting - Allows for vertical aiming adjustment.

1. Mark and drill the desired location on mounting surface.
2. Secure trunnion mounting arm to surface using 1/2" bolts or lag screws (not included) as appropriate for the mounting surface.

Wiring

1. For Trunnion and Wall Bracket Mounting Installations: Use a suitable junction box (Cooper Crouse-Hinds EABC26, not provided) to make the wiring transition from rigid conduit to the required Class I flexible coupling. To allow for aiming angle adjustment, mount this junction box close to the trunnion arm or wall bracket.
2. All conduit entries must be sealed within five feet of FZD housing. Sealing fitting must be installed before conduit enters junction box or slipfitter and on the fixture side of flexible coupling. Use a Cooper Crouse-Hinds EYS216 sealing fitting.
3. Attach a Cooper Crouse-Hinds 30-inch long explosionproof flexible coupling (Cooper Crouse-Hinds ECLK230) from the wall mount junction box or pole mount SFA6-XP slipfitter to an EYS and then the FZD housing. If a longer coupling is required, a 33-inch ECLK233 or 36-inch ECLK236 can be used.
4. Loosen yoke adjuster locking screw until it no longer engages the yoke adjuster. Loosen yoke bolts and position floodlight to provide access to the wiring chamber

cover. Reverse this step when wiring is complete. Tighten yoke bolts to 70 ft. lbs.

5. Remove the wiring chamber cover.
6. Connect supply wires to floodlight leads per the attached wiring diagrams using methods that comply with all applicable codes. Tighten all electrical connections.
7. Reassemble the wiring chamber cover to the housing and hand tighten securely. Once complete, make sure EYS is sealed using Crouse-Hinds CHICO.
8. All unused conduit entries must be closed up. Close with pipe plug supplied with unit. To prevent galling, lubricate pipe plugs with Cooper Crouse-Hinds HTL Lubricant before installing.

Wiring Alternative

As an alternative to the wiring method described above, MC-HL type cable may be used. Crouse-Hinds TMCX fittings are suitable to connect MC-HL cable from FZD housing to EABC type junction box. TMCX fittings must be sealed using TSC type compound.

Lamp Installation and Replacement

1. Disconnect the power to the floodlight and allow to cool completely.
2. Disengage locking set screw located on Socket Holder. See Figure 1.

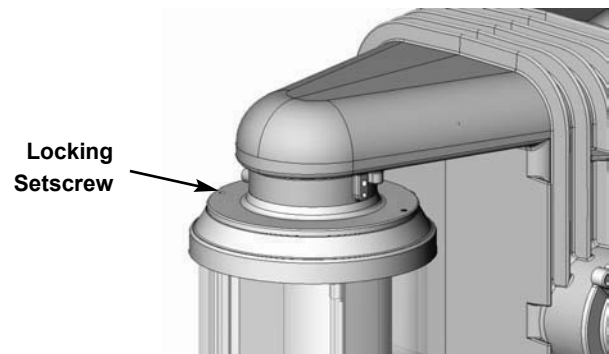

Figure 1

3. Remove the lamp tube assembly by turning counterclockwise.
4. Remove lamp.
5. Perform cleaning and inspection as noted in the MAINTENANCE section.

⚠ CAUTION

To prevent ballast damage on high pressure sodium luminaires, replace burned out lamps as soon as possible

To avoid shortened lamp life, lampholder failure, wiring faults, or ballast failure, tighten lamp firmly and completely

To avoid injury, guard against lamp breakage

6. Screw new lamp into lampholder and securely tighten lamp. New lamp must be identical type, size, and wattage as marked on the floodlight nameplate.
7. Reassemble the lamp tube assembly to the housing by turning clockwise and tighten securely.
8. Tighten locking set screw.

Final Adjustment

1. To make final vertical adjustment, loosen the yoke adjuster locking screw until it no longer engages the yoke adjuster. Loosen yoke bolts and position to desired vertical angle. Re-engage yoke adjuster lock screw into yoke adjuster. Note that the yoke adjuster hole pattern allows for 10° increment of aiming angle. Use threaded hole in yoke arm that aligns with yoke adjuster when floodlight is at desired vertical angle. Tighten yoke bolts to 70 ft. lbs.

Ballast Cover Removal and Installation

1. Remove the ballast cover on the back of the floodlight for access to the ballast. This may be required to change ballast voltage taps or during maintenance.
2. Reassemble ballast cover and hand tighten securely.

Maintenance

- Perform visual, electrical, and mechanical inspections on a regular basis. The environment and frequency of use should determine this. However, it is recommended that checks be made at least once a year. We recommend an Electrical Preventive Maintenance Program as described in the National Fire Protection Association Bulletin NFPA No. 70B: Recommended Practice For Electrical Equipment Maintenance (www.nfpa.org).
- The lamp tube assembly should be cleaned periodically to insure continued lighting performance. To clean, wipe the refractor with a clean, damp cloth. If this is not sufficient, use a mild soap or a liquid cleaner such as Collinite NCF or Duco #7. Do not use an abrasive, strong alkaline, or acid cleaner. Damage may result.
- Visually check for undue heating evidenced by discoloration of wires or other components, damaged parts, or leakage evidenced by water or corrosion in the interior. Replace all worn, damaged, or malfunctioning components and clean gasket seals before putting the fixture back into service.
- Electrically check to make sure that all connections are clean and tight.
- Mechanically check that all parts are properly assembled.

REPLACEMENT PARTS

Cooper Crouse-Hinds FZD Series Floodlight Luminaires are designed to provide years of reliable lighting performance. However, should the need for replacement parts arise, they are available through your authorized Cooper Crouse-Hinds distributor. Assistance may also be obtained through your local Cooper Crouse-Hinds representative or the Cooper Crouse-Hinds Sales Service Department, P.O. Box 4999, Syracuse, New York 13221, Phone 315/477-7000.

WIRING DIAGRAMS

Metal Halide (MH) - 175, 250 and 400 watts
all voltages

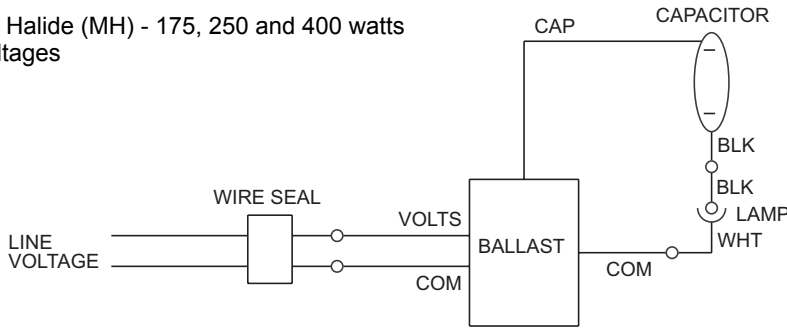

High Pressure Sodium (HPS) - 150 watts
120, 208, 240, 277 (MT) and 480V
120, 277, 347 (TT)

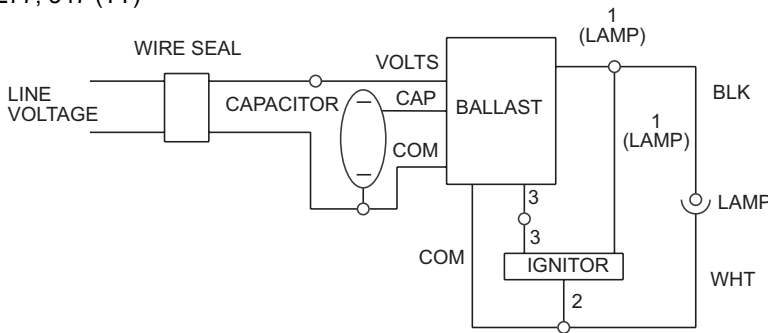

High Pressure Sodium (HPS) - 250 and 400
watts all voltages

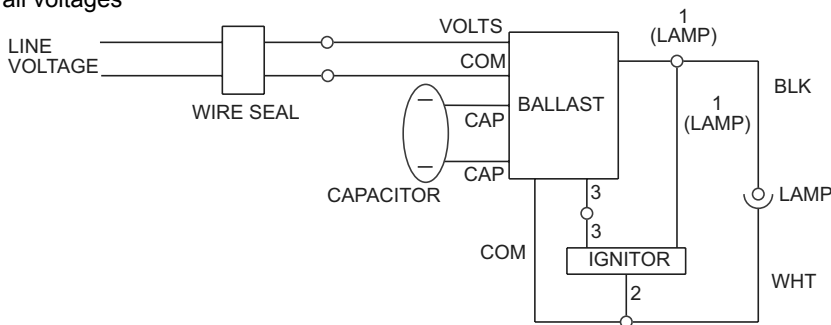

Rapid Restrike Option - 150(LX)
HPS only (Catalog Suffix IR)

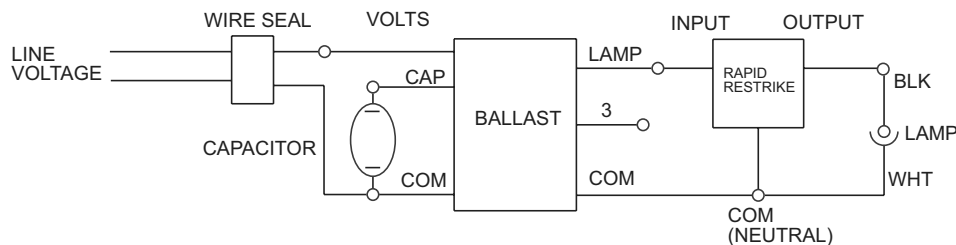

All statements, technical information and recommendations contained herein are based on information and tests we believe to be reliable. The accuracy or completeness thereof are not guaranteed. In accordance with Cooper Crouse-Hinds "Terms and Conditions of Sale", and since conditions of use are outside our control, the purchaser should determine the suitability of the product for his intended use and assumes all risk and liability whatsoever in connection therewith.