

CHAMP HID Floodlight F2MV Series 70-150 Watts

Installation & Maintenance Information

IF 1412

SAVE THESE INSTRUCTIONS FOR FUTURE REFERENCE

APPLICATION

CHAMP F2MV series floodlights are designed to use in areas classified as Class I, Division 2 or Class I, Zone 2 hazardous (classified) locations as defined by the National Electrical Code. Refer to the fixture nameplate for specific classification information and operating temperature (T) rating.

F2MV series floodlights are designed for use in wet locations, outdoor marine and industrial locations, indoors and outdoors where moisture, dirt, corrosion, vibration and rough usage may be a problem.

F2MV Series floodlights are supplied with a choice of voltage (120, 208, 240, 277, 347, and 480 volts, 60 Hz., as well as 220

and 240 volts, 50 Hz.), and light sources (Mercury Vapor [MV], Metal Halide [MH], or High Pressure Sodium [HPS]), in ratings of 70 through 175 watts.

F2MV series floodlights are suitable for operation in ambient temperatures (as measured at the mounting position) as marked on the fixture nameplate.

⚠ WARNING

To avoid the risk of fire and electric shock, this product should be installed, inspected, and maintained by a qualified electrician only.

⚠ WARNING

To avoid electric shock:

- Be certain power is OFF before and during installation and maintenance.
- Fixture must be supplied by a wiring system with an equipment grounding conductor.

To avoid explosion:

- Do not install where marked operating temperatures exceed ignition temperature of hazardous atmospheres.
- Do not operate in ambient temperatures above those indicated on fixture nameplate.
- Use only lamp type and wattage specified on nameplate of fixture.
- Disconnect the fixture from the supply circuit before opening. Keep tightly closed when in operation.
- Do not position the fixture beyond the aiming range limits.

To avoid burning hands while performing maintenance, make sure lens and lamp are cool.

INSTALLATION

MOUNTING

Slipfitter Mounting:

For a slipfitter mounting, use the Crouse-Hinds slipfitter attachment SFA6.

1. Using the 1/2" bolts provided with the slipfitter assembly, securely fasten the yoke mount bracket to the vertical flange on the SFA6. Torque bolts to 45 ft.-lbs.
2. Mount the fixture and slipfitter to the pole and make connections to the supply circuit using the installation instructions included with the SFA6.
3. Loosen two pivot bolts and two locking bolts on yoke. Position the floodlight at an angle to provide access to the wiring compartment. Securely tighten all four bolts on yoke. Proceed to wiring instruction section.

Yoke Mounting:

1. Mark and drill desired location on mounting surface.
2. Secure yoke mounting arm to surface using 1/2" bolts or lag screws (not included).
3. A suitable junction box with a cord connector, such as a Crouse-Hinds GRFX box with a CGB cord connector, is recommended to connect extra hard usage cord from the fixture to the supply circuit.
4. Loosen two pivot bolts and two locking bolts on yoke. Position floodlight at an angle to provide access to the wiring compartment. Securely tighten all four bolts on yoke.

Floodlight Dimensions

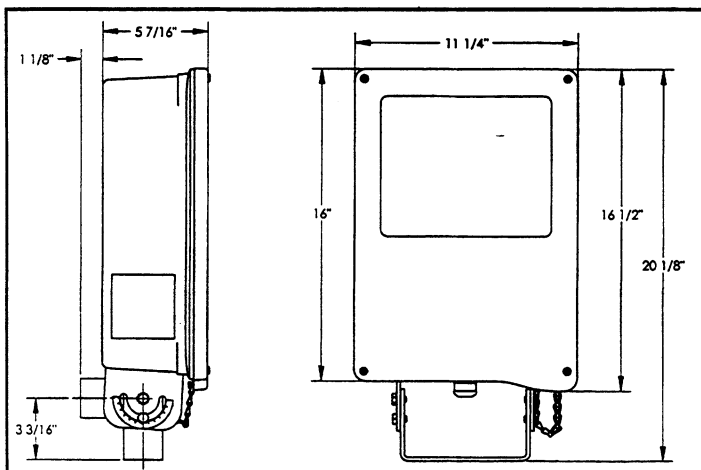

Yoke Mount Dimensions

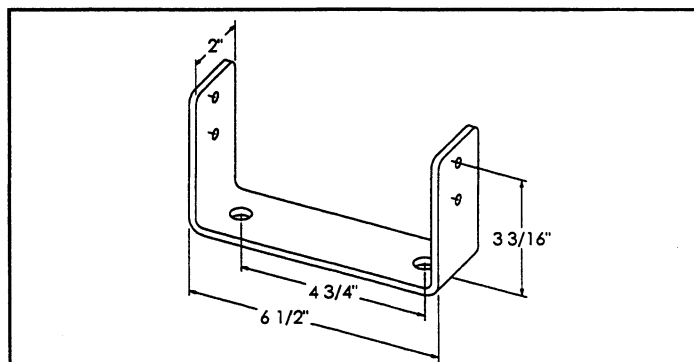

WIRING

1. Completely loosen the four captive floodlight cover screws.
2. Carefully remove floodlight cover from housing.
3. Install the body of the CGB294 cord connector (supplied with the fixture) into the open conduit entrance in the floodlight housing, using a small amount of HTL thread lubricant. Assemble the cord connector according to the instructions supplied.
4. Cut a suitable length of 3-conductor extra hard usage cord (for example type SO or type G). Install cord through the CGB cable connector into floodlight housing.
5. Connect supply wires to floodlight leads per the attached wiring diagrams using methods that comply with NEC and any local codes. Make sure that supply voltage is the same as the fixture voltage. Tighten all electrical connections.
6. Close floodlight cover door and securely tighten all cover screws. For proper gasket seal, torque the cover screws to 30-40 in.-lbs.

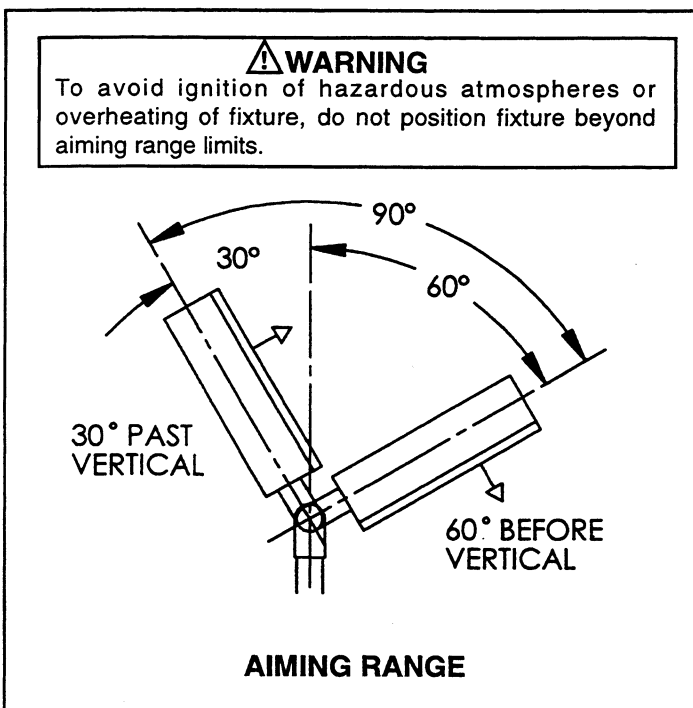

7. To make final vertical adjustment, loosen two pivot bolts and two locking bolts on floodlight yoke and position to desired vertical angle. Check to make sure the vertical angle is within the aiming range limits shown. Tighten all four bolts to 11 ft.-lbs. torque.

LAMP INSTALLATION AND REPLACEMENT

1. Note both vertical and radial aiming angles. If these are disturbed during relamping they should be readjusted after relamping.
2. Disconnect power to fixture and allow unit to cool completely.
3. Completely loosen all four captive cover screws holding floodlight cover.
4. Carefully open cover from floodlight housing. Care should be taken to prevent damage to cover gasket.
5. Remove lamp.

6. Using a clean, dry, soft cloth wipe both sides of floodlight lens and the reflector to remove dust and dirt that may have accumulated on the lens or reflector.
7. Perform visual, electrical and mechanical inspection as noted in Maintenance Section.
8. Screw new lamp into lampholder and securely tighten lamp. Always use a lamp that is the identical type, size and wattage as marked on the fixture nameplate.

⚠ CAUTION

To avoid shortened lamp life, lampholder failure, wiring faults or ballast failure, tighten lamp firmly and completely.

To avoid injury, guard against lamp breakage.

9. Close cover door and securely tighten all cover screws. For proper gasket seal, torque the cover screws to 30-40 in. lbs.

MAINTENANCE

Perform visual, electrical and mechanical inspections on a regular basis. This should be determined by the environment and frequency of use. However, it is recommended that checks be made at least once a year. We recommend an Electrical Preventive Maintenance Program as described in the National Fire Protection Association Bulletin NFPA No. 70B. The lens should be cleaned periodically to insure continued lighting performance. To clean, wipe the lens with a clean, damp, soft cloth. If this is not sufficient, use a mild soap or a liquid cleaner such as Collinite NCF or Duco #7. DO NOT use an abrasive, strong alkaline or acid cleaner.

- Relamp high pressure sodium fixtures as soon as possible after the lamp burns out to prevent damage to the ballast.
- Visually check for undue heating evidenced by discoloration of wires or other components, damaged parts, or leakage evidenced by water or corrosion in the interior. Replace all damaged or malfunctioning components before putting the fixture back into service.
- Electrically check to make sure that all connections are clean and tight.
- Mechanically check that all parts are properly assembled.

WIRING DIAGRAMS

Metal Halide (MH) - 70 and 100 watts, all voltages
 High Pressure Sodium (HPS)- 70, 100 and 150 watts
 all voltages

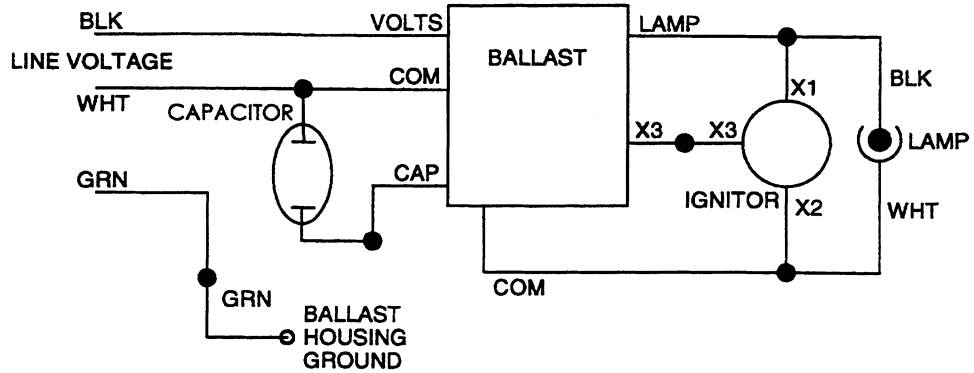

Mercury Vapor (MV) - 100 and 175 watts
 all voltages
 Metal Halide (MH) - 175 watts
 all voltages

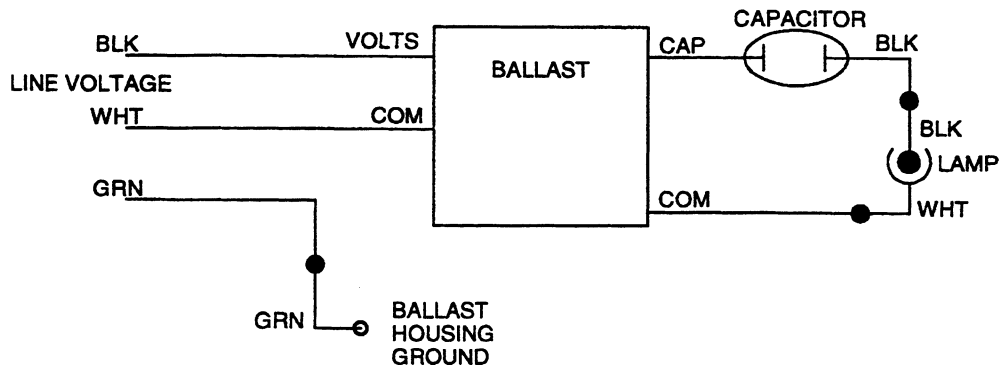

Rapid Restrike Option (catalog suffix IR) -
 High Pressure Sodium (HPS) only
 70, 100 and 150 watts, all voltages

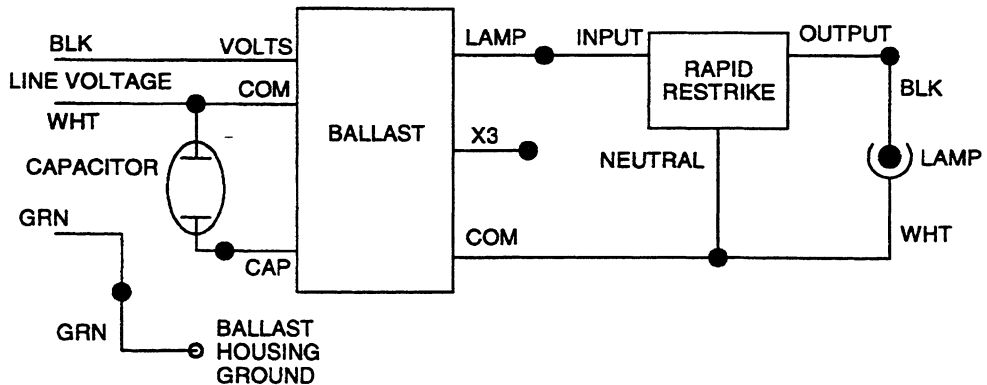



Cooper Industries Inc.
Crouse-Hinds Division
PO Box 4999, Syracuse, New York 13221 • U.S.A.
Copyright© 1999, Cooper Industries, Inc.

IF 1412
Revision 1
New 8/99

All statements, technical information and recommendations contained herein are based on information and tests we believe to be reliable. The accuracy or completeness thereof are not guaranteed. In accordance with Crouse-Hinds "Terms and Conditions of Sale", and since conditions of use are outside our control, the purchaser should determine the suitability of the product for his intended use and assumes all risk and liability whatsoever in connection therewith.
