

SAVE THESE INSTRUCTIONS FOR FUTURE REFERENCE

IMPORTANT SAFEGUARDS

READ AND FOLLOW ALL SAFETY INSTRUCTIONS

- a) Do not use emergency luminaire for other than its intended use.
- b) The use of accessory equipment not recommended by the manufacturer may cause an unsafe condition.
- c) Electrical power must be turned OFF before and during installation and maintenance.
- d) Free installation area of hazardous atmospheres before opening to reduce the risk of accidental explosion due to inadvertent shorting of the emergency ballast.
- e) Emergency luminaire should be mounted in locations and at heights where it will not readily be subjected to tampering by unauthorized personnel.
- f) Do not mount near gas or electric heaters.
- g) Emergency luminaire must be supplied by a wiring system with an equipment grounding conductor.
- h) The rechargeable battery power supply is internal to the emergency ballast and cannot be serviced.
- i) If the emergency ballast requires replacement, it must be recycled. Refer to the recycling information printed on the emergency ballast.

SAVE THESE INSTRUCTIONS



APPLICATION

Champ® DMVF(B) Series Luminaires are suitable for use in the following hazardous (classified) areas as defined by the National Electrical Code (NEC®) and Canadian Electrical Code (CEC):

- Class I, Division 2, Groups A, B, C, D; Class I, Zone 2 II
- Class I, Zone 2, AEx nR II, Ex nR II
- Class II, Groups E, F, G; Simultaneous Presence; Class III

Refer to the luminaire nameplate for specific classification information, maximum ambient temperature suitability, and corresponding operating temperature (T-Code).

DMVF(B) Series Luminaire 4X / IP66 construction is designed for use indoors and outdoors in marine and wet locations, where moisture, dirt,

corrosion, vibration, and rough usage may be present

DMVF(B) Series Luminaires are for use with a choice of voltages and require two 26 32, or 42 watt compact fluorescent lamps base type GX24q-3.

The DMVFB Series Emergency Luminaire is also supplied with an emergency ballast. When AC power is interrupted, the luminaire switches to a built-in battery power supply (integral to the emergency ballast) to light one lamp, providing emergency lighting for a minimum of 90 minutes. When AC power is restored, the luminaire automatically switches from battery power to AC power. While operating on AC power, the luminaire circuitry recharges the battery.

WARNING

To avoid the risk of fire, explosion, or electric shock, this product should be installed, inspected, and maintained by a qualified electrician only, in accordance with all applicable electrical codes.

WARNING

To avoid electric shock:

Be certain electrical power is OFF before and during installation and maintenance.

Luminaire must be supplied by a wiring system with an equipment grounding conductor.

To avoid burning hands:

Make sure refractor and lamp are cool when performing maintenance.

WARNING

To avoid explosion:

Make sure the supply voltage is the same as the luminaire voltage.

Do not install where the marked operating temperatures exceed the ignition temperature of the hazardous atmosphere.

Do not operate in ambient temperatures above those indicated on the luminaire nameplate.

Install luminaire with lamp base up within 25° of vertical position.

Use only the lamp and wattage specified on the luminaire nameplate.

Use proper supply wiring as specified on the luminaire nameplate.

All gasket seals must be clean.

Before opening, electrical power to the luminaire must be turned off. Keep tightly closed when in operation.

INSTALLATION

Mounting

1. Mount the cover module in its support position.
 - Ceiling and Wall mount: Mark and drill desired location on mounting surface. Secure with 5/16" bolts or lag screws (not provided).
 - Pendant, Stanchion and Quad mount: Securely thread onto the appropriate NPT size conduit. Tighten setscrew located in the conduit hub. See Figure 1.

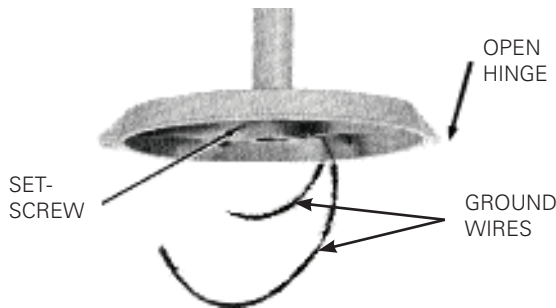

FIGURE 1

Wiring

1. Pull field wiring into cover module.
2. Close all unused conduit entries with conduit plugs provided. To prevent galling, lubricate conduit plugs with Cooper Crouse-Hinds HTL lubricant before installing. Tighten plugs securely with at least three full threads engaged.
3. Hang ballast housing on the cover module hinge hook. See Figure 2.
4. Connect supply wires to luminaire wire leads (or terminals) per the attached wiring diagrams using methods that comply with all applicable codes. Tighten all electrical connections.
5. On DMVFB Series Emergency Luminaires, connect the emergency ballast connector (white/red wires). See Figure 2. This is disconnected to avoid discharging the battery during shipment.

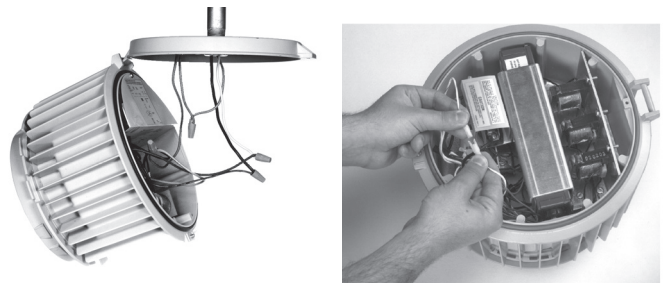

FIGURE 2

6. Close ballast housing onto cover module making sure that all wires are safely inside and positioned away from the ballast area. Tighten captive closing screw to 30 in.-lbs. (3.4 N-m).
7. Install two lamps as specified on the nameplate. See LAMP INSTALLATION AND REPLACEMENT section.
8. Apply a small amount of HTL®Lubricant to threads of globe.
9. Install globe by placing over lamp and hand tighten onto threaded luminaire housing.
10. Install reflector and wire guard (optional). See the instructions that follow.
11. Installation is now complete and power may be turned on. For proper operation in the emergency mode, allow 24 hours charge time.

DMVFB SERIES PUSH-TO-TEST SWITCH

A remote push-to-test switch (not supplied) suitable for the classified area must be wired in the supply circuit to periodically test the emergency operation feature (see wiring diagram). Cooper Crouse-Hinds recommends a Crouse-Hinds EDSC2192 for Class I, Division 2 Groups B, C, D applications.

LAMP INSTALLATION AND REPLACEMENT

1. Disconnect power to luminaire and allow to cool completely.
2. For DMVFB emergency luminaires, open the ballast housing and disconnect the emergency ballast connector (white/red wires). This will disconnect the emergency ballast charged battery from the lamp receptacle. Close the ballast housing to facilitate globe removal.
3. Unthread and remove globe for access to lamps. It is not necessary to remove the guard.
4. Remove lamp(s).
5. Perform cleaning and inspection as noted in the MAINTENANCE section.
6. Place new lamp into lampholder and push in to secure. New lamp must be identical type, size and wattage as marked on the



CAUTION

To avoid shortened lamp life, lampholder failure, wiring faults or ballast failure, secure lamp firmly and completely.

To avoid injury, guard against lamp breakage.

luminaire nameplate.

7. Thoroughly clean or replace the globe gasket seal.
8. Thread the globe into the ballast housing and hand tighten securely.
9. For DMVFB emergency luminaires, open the ballast housing and re-connect the emergency ballast connector. Close the ballast housing and tighten the captive closing screw to 30 in.-lbs (3.4 Nm).
10. Restore power.

WIRE GUARD INSTALLATION

1. To install wire guard, place over globe and press into position over retaining bosses on the luminaire housing adapter ring.
2. To remove guard, carefully pry open guard at the retaining bosses and pull off.

REFLECTOR INSTALLATION

Both dome and 30° angle reflectors incorporate an innovative design that requires no tools or attachment hardware.

To install:

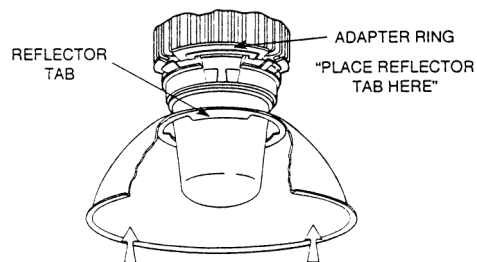

FIGURE 3

1. Place the reflector in position on the luminaire housing adapter



CAUTION

To avoid injury, do not lean on luminaire or use it as a support. Make sure that footing is secure while installing reflector.

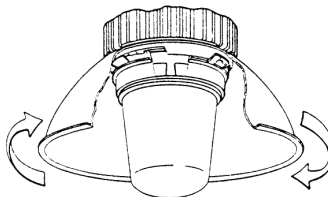

FIGURE 4

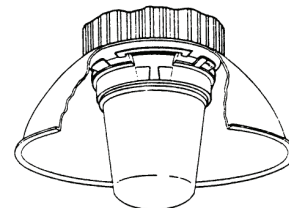

FIGURE 5

ring. When correctly placed, all three tabs of reflector will rest on areas marked "Place Reflector Tab Here" on adapter ring. See Figure 3.

2. Rotate reflector clockwise so that the three tabs slide under captivated bosses on adapter ring. See Figure 4.
3. Continue to rotate reflector clockwise until reflector tabs engage final captivated bosses and the reflector "snaps into position." See Figure 5.

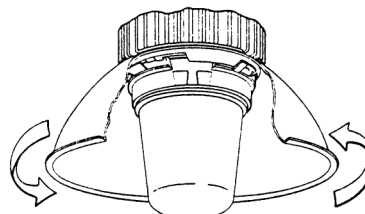

FIGURE 6

4. When correctly installed, the position labels inside the reflector will be aligned with the "STOP" indicator on adapter ring.
5. The reflector can be removed by rotating counterclockwise until the three reflector tabs are free of the captivated bosses. See Figure 6.

MAINTENANCE

- Perform visual, electrical, and mechanical inspections on a regular basis. The environment and frequency of use should determine this. However, it is recommended that checks be made at least once a year. We recommend an Electrical Preventive Maintenance Program as described in the National Fire Protection Association Bulletin NFPA No. 70B: Recommended Practice For Electrical Equipment Maintenance (www.nfpa.org).
- The globe (and guard and reflector when used) should be cleaned periodically to insure continued lighting performance. To clean, wipe the reflector, then the globe with a clean damp cloth. If this is not sufficient, use a mild soap or a liquid cleaner such as Collinite NCF or Duco #7. Do not use an abrasive, strong alkaline, or acid cleaner. Damage may result.
- Visually check for undue heating evidenced by discoloration of wires or other components, damaged parts, or leakage evidenced by water or corrosion in the interior. Replace all worn, damaged, or malfunctioning components and clean gasket seals before putting the luminaire back into service.
- Electrically check to make sure that all connections are clean and tight.
- Mechanically check that all parts are properly assembled.

FIELD ASSEMBLED LUMINAIRES

Champ DMVF and DMVFB Series Luminaires.

Complete luminaire consists of cover, ballast housing and globe with or without guard or reflector.

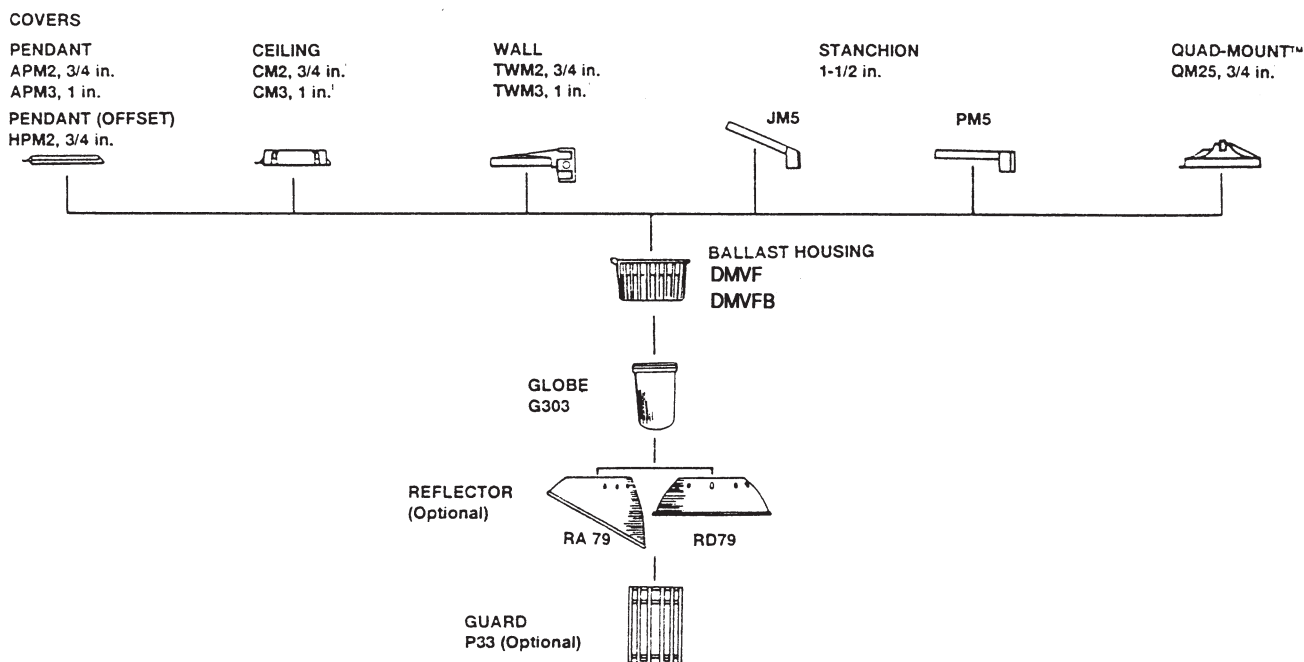

DMVFB EMERGENCY BALLAST INFORMATION

DMVFB Series Emergency Luminaires are supplied with an emergency ballast system. Disconnect the emergency ballast connector prior to performing maintenance. This will disconnect the charged battery from the lamp receptacle.

The emergency ballast must be checked periodically to insure that it is working properly.

The following schedule is recommended:

1. Visually inspect the charging indicator light monthly. It should be illuminated at all times. This indicates that the battery is being charged. Test the emergency operation of the luminaire, at this time, for a minimum of 30 seconds. This can be done disconnecting the power to the luminaire. One lamp should operate with reduced intensity.
2. Conduct a 90 minute discharge once a year. One lamp should operate at a reduced intensity for at least 90 minutes.

REPLACEMENT PARTS

Crouse-Hinds DMVF(B) Series Champ Luminaires are designed to provide years of reliable lighting performance. However, should the need for replacement parts arise, they are available through your authorized Crouse-Hinds distributor. Assistance may also be obtained through your local Crouse-Hinds representative or the Crouse-Hinds Sales Service Department, P.O. Box 4999, Syracuse, New York 13221, Phone 315-477-7000.

WIRING DIAGRAMS

DMVF052, 064, & 084 with 2 lamps

(120-277V 50-60 Hz or 347V, 60 Hz)

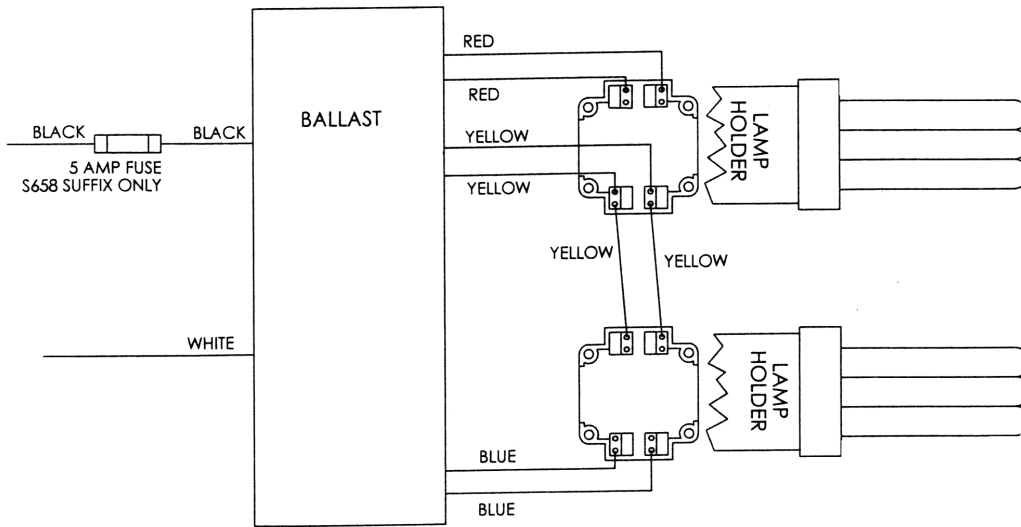

DMVFB052, 064, and 084 with 2 lamps

(120-277V 50-60 Hz or 120V, 60 Hz (Canada) or 347V, 60 Hz)

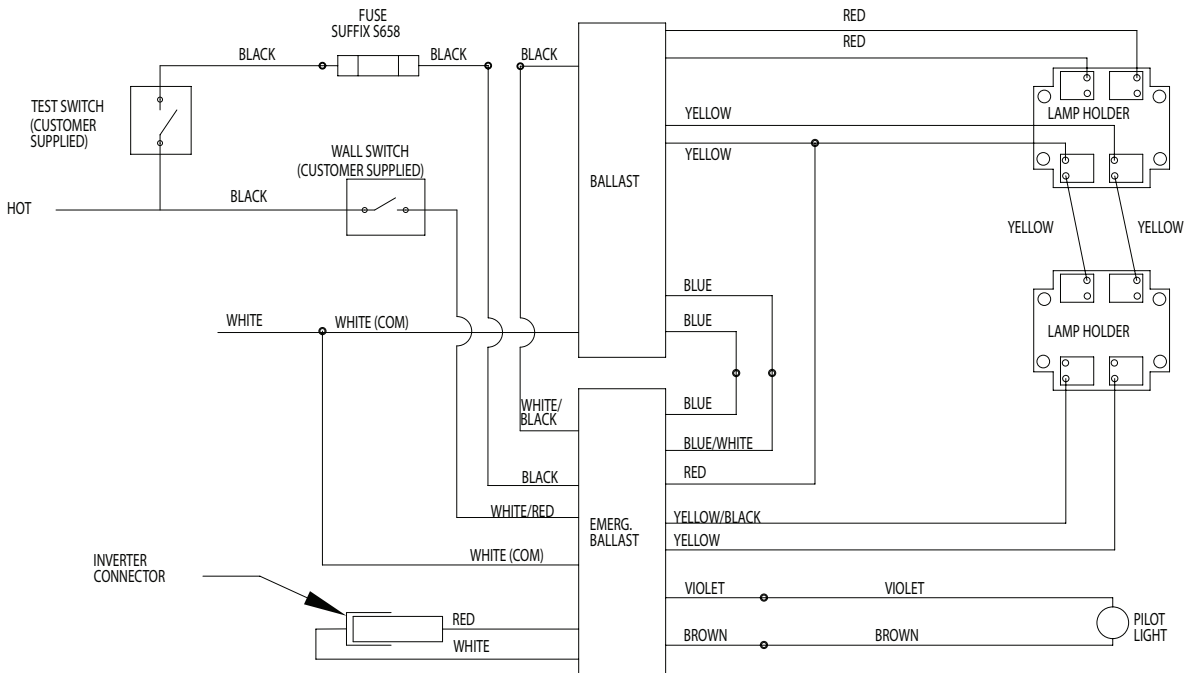

All statements, technical information and recommendations contained herein are based on information and tests we believe to be reliable. The accuracy or completeness thereof are not guaranteed. In accordance with Crouse-Hinds "Terms and Conditions of Sale," and since conditions of use are outside our control, the purchaser should determine the suitability of the product for his intended use and assumes all risk and liability whatsoever in connection therewith.