



The ILLUMINATOR™ (EVFT) Fluorescent Lighting Fixture For Class I, Group B & C Applications

SAVE THESE INSTRUCTIONS
FOR FUTURE REFERENCE

IF1194

Installation & Maintenance Information

APPLICATION

ILLUMINATOR fluorescent lighting fixtures marked with the suffix “-GB” on the fixture nameplate are suitable for Class I, Groups B, C, D; Class II, Groups E, F, G; Class III, and simultaneous presence hazardous (classified) locations as defined by the National Electrical Code®. These fixtures are factory sealed; external seals are not required. The T-Rating of the fixture must not exceed the ignition temperature of the atmosphere in which it is to be operated. Refer to the fixture nameplate for specific classification information and appropriate operating temperature (T) rating.

ILLUMINATOR fluorescent lighting fixtures are also suitable for use in marine locations and paint spray areas. They are designed for use in industrial locations where moisture, dirt, and vibration may be a problem.

ILLUMINATOR fixtures are for use with two or four “PL *36”†, “BIAx F39BX”††, or “DULUX L 36W”# single ended fluorescent lamps. The fixture ratings are 78 (2 lamp) or 156 watts (4 lamp). Fixture input voltage is 120 or 277 VAC.

Single-ended fluorescent lamps have operating characteristics similar to conventional F40 fluorescent lamps; they are intended to be used in ambient temperatures of 50° F (10° C) to 104° F (40° C).

ILLUMINATOR fixtures with the suffix “-GB” are installed in the conduit system through the pendant hub only.

Review and obtain a thorough understanding of these instructions before proceeding with installation of the fixture. It will ultimately save time and help insure proper installation.

FIXTURE INSTALLATION

NOTE: All threaded joints are “O” ring sealed for marine location suitability. Exercise care:

- during assembly, to ensure threaded components are thoroughly tightened over “O” rings.
- during disassembly to avoid accidental damage to the “O” ring.

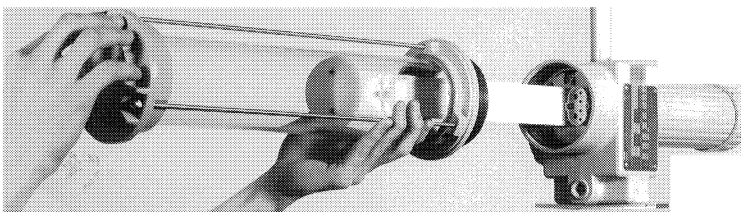
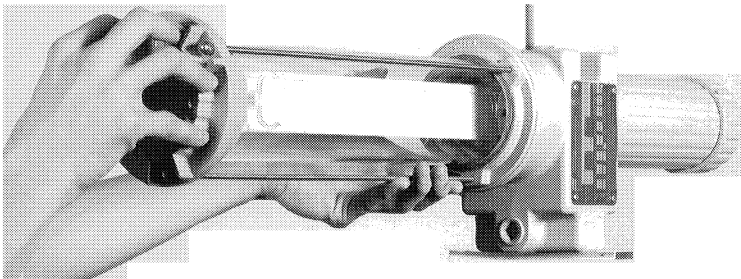

1. Loosen set screw in flange of lamp tube at main housing.
2. Position hands over lamp tube assembly. Remove lamp tube assembly by unthreading counter-clockwise until disengaged. Carefully slide off over ground plane. **DO NOT TAMPER WITH CAP NUTS AT END OF LAMP TUBE ASSEMBLY.**

NOTE: Allow the following spacing provisions for fixtures when installing into conduit system:

- Removal of lamp tube assembly - 20 inches
- Removal of ballast housing - 3 inches

† Trademark - Philips Lighting Corp.
†† Trademark - General Electric Co.
Trademark - Osram Corporation
* Registered Trademark - National Fire Protection Association

WARNING

Electrical power must be OFF before and during installation and maintenance.

WARNING

The ILLUMINATOR lighting fixtures are designed for operation only with the lamp in a horizontal to base down position. Do not install in any classified location where marked operating temperatures exceed ignition temperatures of hazardous atmospheres. Do not install fixture in any location where ambient temperature exceeds maximum ambient temperature indicated on fixture nameplate. Keep tightly closed when in operation.

PENDANT MOUNT

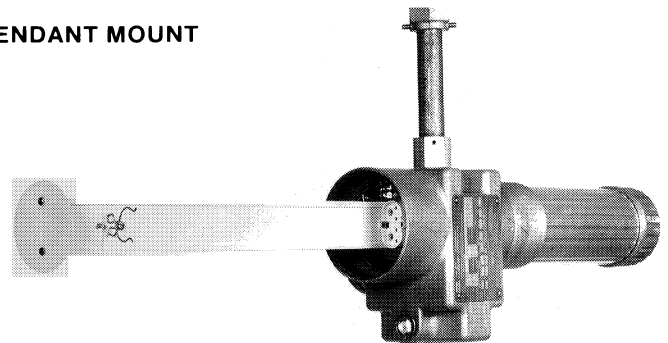

CAUTION

Hub seal assembly is permanently attached to the housing. Do not attempt to remove.

For pendant stem length of 12 inches or less:

1. Feed wires from fixture hub seal through conduit pendant.
2. Engage conduit pendant or pipe nipple to hub seal a minimum of five full threads. Tighten set screw in hub seal.
3. Feed wire leads from conduit pendant into fixture hanger/outlet body, pulling excess conductor length through access opening. (Access cover has been removed.)

NOTE: Recommended fixture hanger/outlet body is Crouse-Hinds ECM catalog number EAHC2602 fixture hanger with union hub.

WARNING

Fixture hanger/ Outlet body must be suitable for use in hazard present.

4. Install conduit stem to fixture hanger/outlet body union hub, engage a minimum of five full threads. Tighten set screws in union hub.
5. Proceed to "Fixture Wiring" instructions.

For pendant stem length greater than 12 inches:

Consult NEC Code and/or other applicable codes for additional hanging requirements.

NOTE: Depending on fixture configuration and accessories, extra support may be required to hold the fixture in a perfectly horizontal position if flexible mounting, such as a flexible coupling or flexible hanger is employed. The alternate mounting method of bracing a fixed conduit stem should be considered.

FIXTURE WIRING

NOTE: The Illuminator fixtures are factory wired. It is NOT necessary to remove the access cover to the center (main) housing, the ballast compartment end cap, or the ballast during installation.

1. Feed supply conductors into access opening of fixture hanger/outlet body.
2. Use proper temperature rated wire as indicated on the fixture nameplate. Connect fixture leads in fixture hanger/outlet body to supply leads as follows:
 - Connect black fixture lead to 120 volt or 277 volt supply lead (voltage shown on fixture nameplate).
 - Connect white fixture lead to neutral supply lead.
 - Connect fixture ground lead (green) to system ground conductor.

NOTE: Fixture is provided with 35 inch leads; cut leads as required to proper length.

IMPORTANT: Attach system ground conductor to fixture ground lead (green) inside fixture hanger/outlet body.

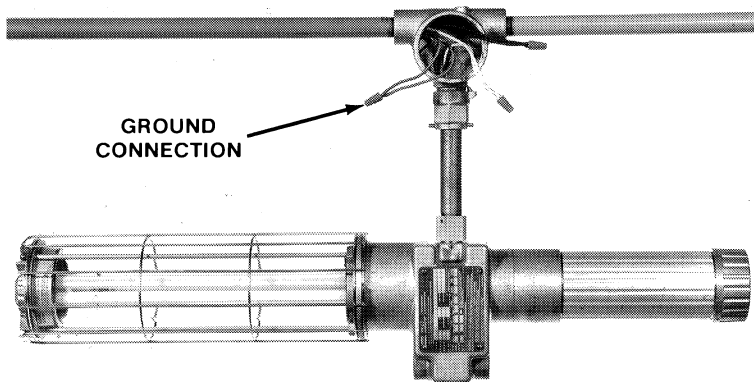

WARNING

Use fixture only on grounded system. Make sure that supply voltage is the same as marked on fixture nameplate.

3. Place all wire connections well within outlet body away from access opening area. Replace and thoroughly tighten access cover to fixture hanger/outlet body.

LAMP/LAMP TUBE INSTALLATION

1. Install lamps (2 or 4) of the proper type and wattage as specified on nameplate. Snap each lamp into support clips attached to ground plane.

CAUTION

Use only size and wattage lamps as specified on nameplate of fixture.

2. Install lamp tube assembly on fixture by placing over lamps and hand tightening into threaded main housing until thoroughly tightened over "O" ring. Tighten set screw in flange of lamp tube.

P51 STAINLESS STEEL GUARD INSTALLATION/REMOVAL

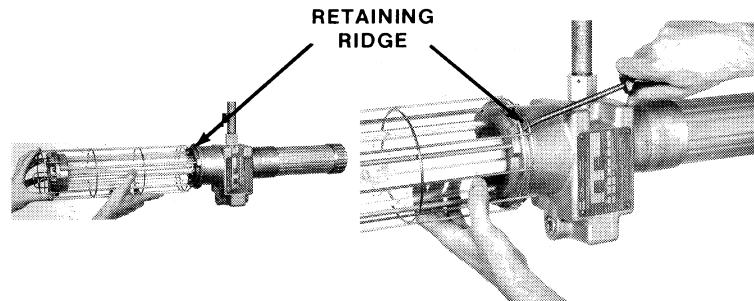

1. Place optional stainless steel guard(s) over lamp tube assembly(s) and push into place over retaining ridge.

NOTE: Guard may be installed prior to installation of lamp tube.
2. For guard removal, carefully pry open guard at retaining ridge and pull off.

PG1 - POLYCARBONATE SHIELD INSTALLATION

(In place of P51 stainless steel guard)

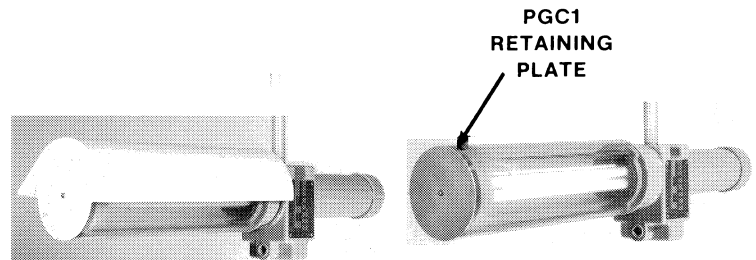

1. Install by sliding over lamp tube assembly.
2. Secure in place with reflector(s) following "Reflector Installation" instructions on following page. If reflector(s) is not used, use PG1 retaining plate(s) supplied with polycarbonate shield(s).

PTW1 - POLYESTER FILM INSTALLATION (Polyester film is used in conjunction only with PG1 polycarbonate clear shield)

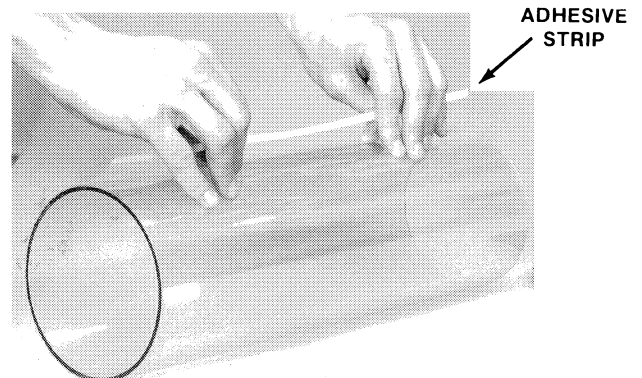

1. Wrap one sheet of polyester film around polycarbonate shield.
2. Remove adhesive strip, overlap and seal.
3. Install polycarbonate shield according to the instructions given above.

REFLECTOR INSTALLATION/REMOVAL

Either an RAR1 right reflector or an RAL1 left reflector is appropriate for two lamp fixture. Four lamp fixture uses one RAR1 and one RAL1.

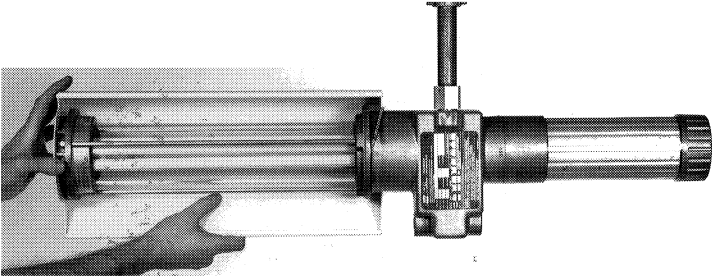

1. Place reflector in desired position (for Class II installations see warning below) on fixture using lamp tube end cap cast-in grooves and center screw hole as a locator.

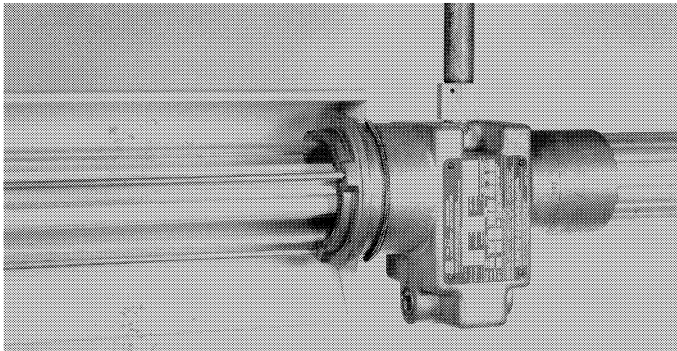

2. Wrap reflector retaining spring around center housing and connect to insert hole.

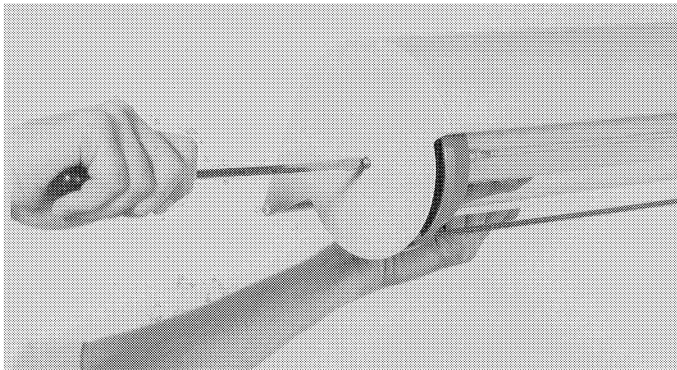

3. Tighten #10 screw screwdriver tight.

To readjust reflector, loosen #10 screw and rotate reflector until in desired position. Retighten screw.

4. To remove reflector, reverse process.

CAUTION

In Class II and Class III locations, do not aim reflector(s) up. Dust or fiber accumulation inside reflector(s) may result in fire or explosion.

RELAMPING

1. Disconnect power to fixture.
2. Remove reflector(s) and/or PG1 polycarbonate shield(s), if used. See "Reflector Installation/Removal" instructions above.
3. Loosen set screw in flange of lamp tube at main housing end (see photos under "Fixture Installation" on page 1 of these instructions). It is not necessary to remove the stainless steel guard if used. **DO NOT TAMPER WITH CAP NUTS AT END OF LAMP TUBE ASSEMBLY.**
4. Grasp lamp tube assembly. Remove lamp tube assembly by unthreading counter-clockwise until disengaged. Carefully slide off over lamps and ground plane.
5. Replace lamp with lamp type and wattage as marked on the fixture nameplate.
6. Replace fixture lamp tube assembly by placing over lamps and threading into main housing until thoroughly tightened over "O" ring.
7. Tighten set screw in flange of lamp tube.
8. Replace reflector(s).

BALLAST REPLACEMENT

WARNING

Be certain that power is OFF before opening ballast or wiring chamber housing.

1. Remove threaded wiring chamber cover from fixture center section. For four lamp fixture, remove wiring chamber cover located closest to nameplate.
2. Remove wire nuts connecting ballast leads with incoming power and lamp sockets. Detach leads. Do not disturb factory seals.
3. Loosen (do not remove) the set screw securing the adapter/ballast housing to the main housing and unthread the adapter/ballast housing.
4. Take adapter/ballast housing to suitable work location.
5. Loosen sealed union nut so as to allow center sealed nipple to rotate. Loosen (do not remove) the set screw securing the adapter and ballast housing.
6. Unthread adapter from ballast housing to expose wire connections.
7. Loosen set screw in end cap, and remove threaded end cap.

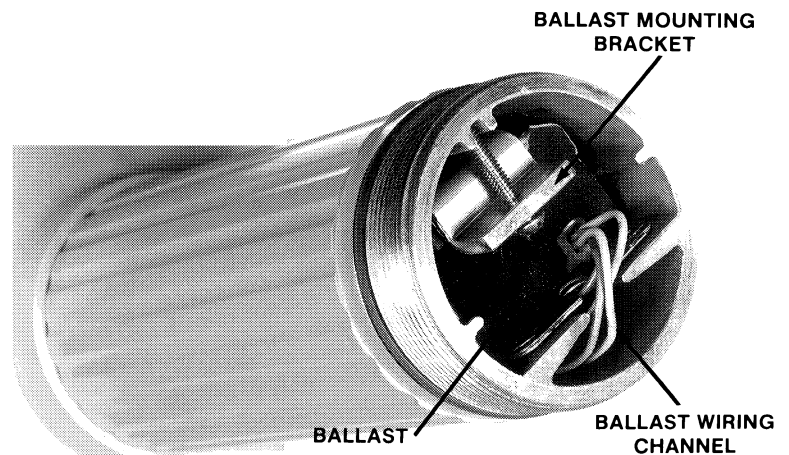

8. Using a screwdriver, loosen the screws at each end of the bracket securing the ballast.
9. Remove ballast and ballast mounting bracket by sliding entire assembly out of ballast housing.
10. Install new ballast with ballast mounting bracket positioned as shown above. With screws aligned with groove above ballast, slide ballast into housing. Feed outbound end wires to channel below ballast mounting surface assuring wires are not pinched between ballast and mounting surface. Direct all wires to end of ballast housing entering main housing. Tighten mounting bracket screws into groove with screwdriver.
11. Cut and strip ballast wires as required, and reattach to seal wires inside adapter housing (color to color) with wire nuts.
12. Reattach adapter assembly to ballast housing allowing seal to rotate within union. Tighten set screw in adapter. Assemble sealed union nut.
13. Thread entire ballast assembly into main housing and lock with set screw. Replace ballast housing end cap and lock with set screw.
14. For adapter/ballast housing installation and circuit connections, reverse steps 1 through 3 above.

MAINTENANCE

WARNING

Always disconnect primary power source before opening fixture for inspection or service.

Perform visual, electrical and mechanical inspections on a regular basis. This should be determined by the environment and frequency of use; however, it is recommended that a check should be made at least once a year. We recommend an Electrical Preventive Maintenance program as described in the National Fire Protection Association Bulletin NFPA No. 70B. The lamp tube and reflector should be cleaned periodically to insure optimum lighting performance. To clean, remove and wipe the reflector, then the lamp tube with a clean, damp, soft cloth. If this is not sufficient, use a mild soap or a liquid cleaner such as Collinite NCF or Duco #7.

REPLACEMENT PARTS

Illuminator™ lighting fixtures are designed to provide years of reliable lighting performance. However, should the need for replacement parts arise, they are available through your Crouse-Hinds Electrical Construction Materials distributor. Assistance may also be obtained through your Crouse-Hinds Sales/Service Department, P. O. Box 4999, Syracuse, New York 13221, phone (315) 477-7000.

All statements, technical information and recommendations contained herein are based on information and tests we believe to be reliable. The accuracy or completeness thereof are not guaranteed. In accordance with Crouse-Hinds "Terms and Conditions of Sale", and since conditions of use are outside our control, the purchaser should determine the suitability of the product for his intended use and assumes all risk and liability whatsoever in connection herewith.



**CROUSE-HINDS
ELECTRICAL
CONSTRUCTION
MATERIALS**