

F115 / F215 SERIES FLUORESCENT LUMINAIRES

Installation & Maintenance Information

SAVE THESE INSTRUCTIONS FOR FUTURE REFERENCE

CAUTION Read carefully before installing and wiring the luminaire. Check the ratings to insure suitability for the area. Must be installed in accordance with the NEC (National Electrical Code) and all other applicable codes. These luminaires are not suitable for hazardous locations.

All luminaires must be properly grounded. These luminaires are supplied with one 1/2" NPT and one 3/4" NPT knockouts. Disconnect the fixture from the supply circuit before opening. Do not attempt to install this luminaire unless you are familiar with warnings, cautions and procedures outlined in this information sheet.

INSTALLATION & ELECTRICAL WIRING

WARNING Risk of electrical shock hazard, only qualified personnel should conduct this procedure!
Do not make electrical connections with the power ON. Use cu or cu clad wire only, see product label for wire temperature rating. Convenience outlet is rated for 125 vac (maximum 15 amp).

1. Make (2) mounting holes for minimum #10 screws (not provided) per mounting dimensions below.

NOTE: This luminaire is for wall mount only.

2. Remove lens cover (5A) by loosening thumb screws (9A) (qty.2x).

3. Remove reflector (0C) by loosening #8 screws and lock washers (9B) (qty.4x, #8-32).

4. Remove knockout on back of housing and install fitting (not provided) to housing (0B).

5. Route supply cable (not provided) thru fitting and tighten securely.

6. Secure housing (0B) to wall with (2) minimum #10 screws (not provided).

7. Strip the supply cable(s) jacket back approximately 2".

Strip the insulation of ground and supply wires approximately 3/8".

CAUTION See product label for voltage input and amperage load per fixture.

8. Using connectors, connect the L1 (hot) wire to black wire terminal. Connect L2 (neutral) to white wire terminal. Connect ground wire to ground screw or green wire. See wiring diagram.

9. Push all wires and connections inside housing (0B) area.

10. Carefully replace reflector (0C) making sure wires are not pinch. Secure with #8 screws and lock washers (9B) (qty.4x, #8-32).

CAUTION Maximum 15 watts Type F15T8 lamp for T8 Bi-Pin G13 socket. Exceeding this can cause over heating, premature failure and be dangerous.

11. Install the proper wattage lamps (not provided) into the lampholders (4B).

12. Replace lens cover (5A) and tighten thumb screws (9A) (qty.2x).

13. Apply power and inspect for proper operation.

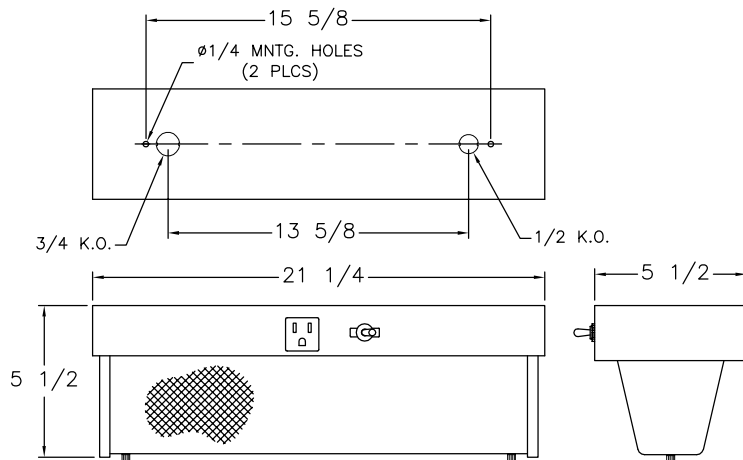
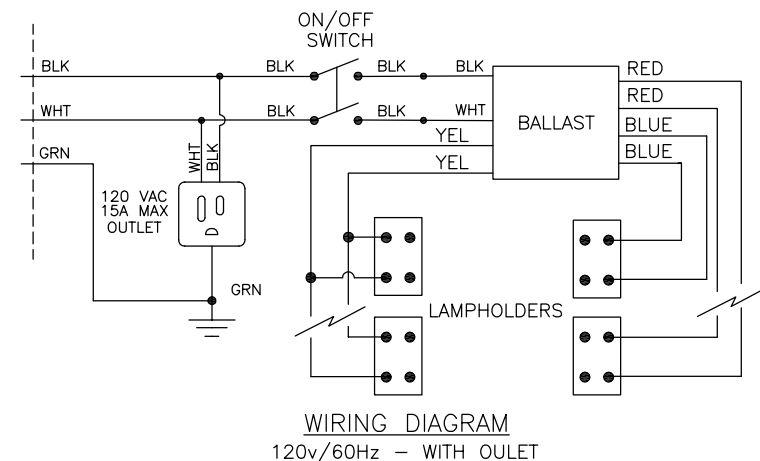
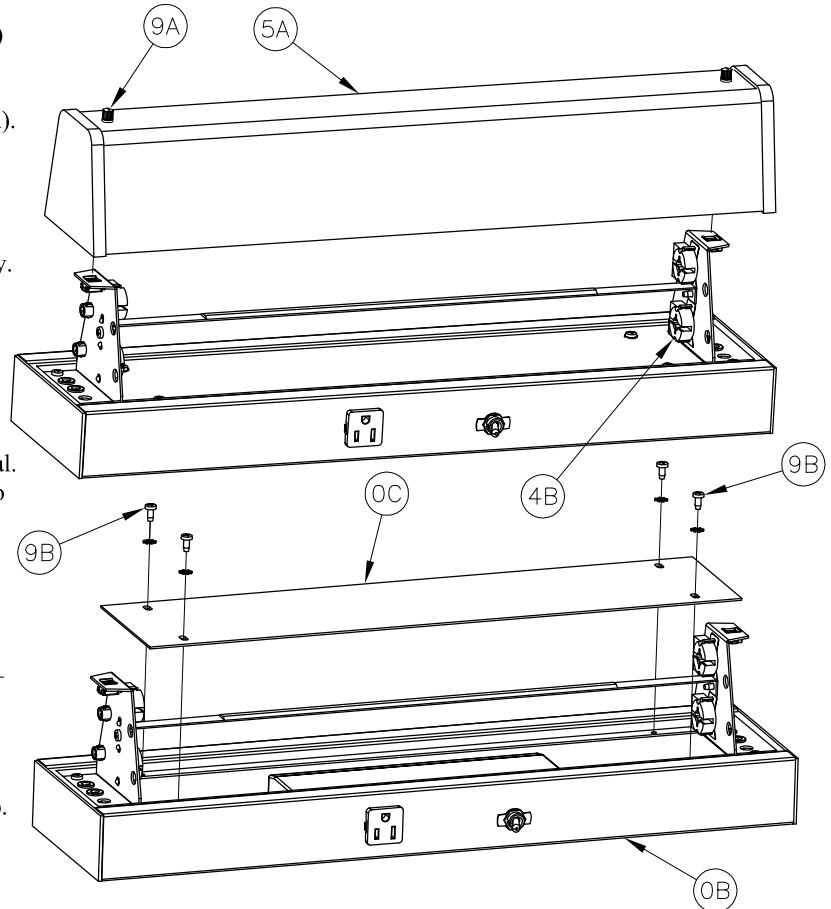

All statements, technical information and recommendations contained herein are based on information and tests we believe to be reliable. The accuracy or completeness thereof are not guaranteed. In accordance with Crouse-Hinds "Terms and Conditions of Sale", and since conditions of use are outside our control, the purchaser should determine the suitability of the product for his intended use and assumes all risk and liability whatsoever in connection therewith.