

INSTALLATION INSTRUCTIONS & PARTS LIST
L-861T, L-861E, L-861 MEDIUM INTENSITY ELEVATED EDGELIGHT
ERL MODEL 5, 6.6A BI-PIN LAMP
40938

WARNING: DE-ENERGIZE CIRCUIT BEFORE RELAMPING OR WORKING
ON FIXTURE

INSTALLATION:

- (A) Assemble the 1" EMT extension column (5) over the lead assy (2) and insert the column into the lower hub of the globe support (1). With the fixture positioned so that the extension column (5) is pointing up and fully bottomed in the four leveling ribs, tighten the three preset leveling screws (12) half a turn each until the extension column (5) is firmly secured to the globe support (1) and perpendicular to the globe mounting surface.
- (B) Assemble the frangible coupling, either (11) or (18) over the lead assy (2) and onto the extension column (5). DO NOT TIGHTEN the coupling binding screw (17).
- (C) Connect the L-823 plug (2) to isolation transformer. Thread Frangible Coupling into baseplate. Recommendation : Apply antiseize compound (Loctite Antiseize thread compound 767 or equal) to coupling threads prior to assembly to baseplate to prevent galling and seizing.
- (D) For dual color fixtures, position the fixture for proper color orientation. Level and align (as necessary) the globe support using P/N 40999 Leveling Fixture. Adjust and tighten appropriate screws to maintain levelness.

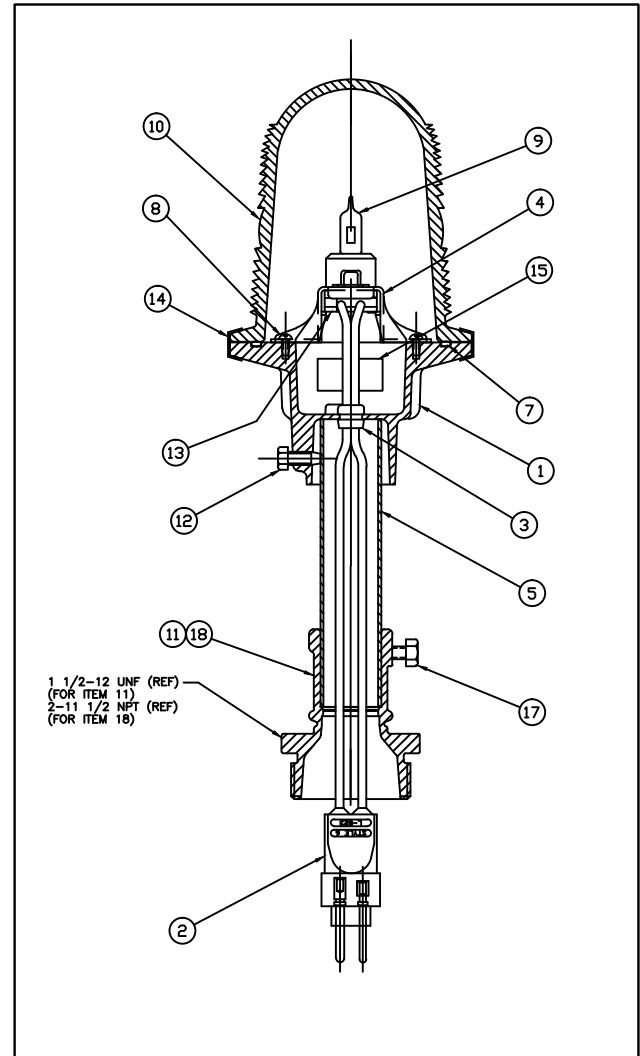

LAMP & GLOBE REPLACEMENT:

- (A) To replace the lamp (9), remove the clamp band (14) and globe (10). Inspect o-ring (7) and other internal components. Replace if necessary. Install new lamp. Reassemble globe (10) and clamp band (14).
- (B) If bulb wall is handled during installation, clean bulb with alcohol and dry with clean soft cloth prior to operating. Contamination of the bulb may result in reduced lamp performance.
(OVER FOR P/L)

WARRANTY

REFER TO EATON'S CROUSE-HINDS AIRPORT LIGHTING PRODUCTS
TERMS AND CONDITIONS PER PRODUCT SPECIFIC WARRANTY INFORMATION.

PARTS LIST
 PART NUMBER 40938 MEDIUM INTENSITY ELEVATED EDGE LIGHT

ITEM NO.	PART NO.	QTY	DESCRIPTION
1	40948	1	SUPPORT, GLOBE
2	40918	1	LEAD ASSY (STANDARD 14" FIXTURE HEIGHT)
	40918-8	1	LEAD ASSY (16" FIXTURE HEIGHT)
	40918-1	1	LEAD ASSY (18" FIXTURE HEIGHT)
	40918-2	1	LEAD ASSY (20" FIXTURE HEIGHT)
	40918-3	1	LEAD ASSY (22" FIXTURE HEIGHT)
	40918-4	1	LEAD ASSY (24" FIXTURE HEIGHT)
	40918-5	1	LEAD ASSY (26" FIXTURE HEIGHT)
	40918-6	1	LEAD ASSY (28" FIXTURE HEIGHT)
	40918-7	1	LEAD ASSY (30" FIXTURE HEIGHT)
	40918-9	1	LEAD ASSY (10" FIXTURE HEIGHT)
3	10047-621	1	STRAIN RELIEF
4	40937	1	BRACKET, SOCKET MOUNTING
5	40878-2P	1	EXTENSION 1" EMT (STANDARD 14" FIXTURE HEIGHT)
	40878-3P	1	EXTENSION 1" EMT 16" FIXTURE HEIGHT
	40878-4P	1	EXTENSION 1" EMT 18" FIXTURE HEIGHT
	40878-5P	1	EXTENSION 1" EMT 20" FIXTURE HEIGHT
	40878-6P	1	EXTENSION 1" EMT 22" FIXTURE HEIGHT
	40878-7P	1	EXTENSION 1" EMT 24" FIXTURE HEIGHT
	40878-8P	1	EXTENSION 1" EMT 26" FIXTURE HEIGHT
	40878-9P	1	EXTENSION 1" EMT 28" FIXTURE HEIGHT
	40878-10P	1	EXTENSION 1" EMT 30" FIXTURE HEIGHT
	40878-11P	1	EXTENSION 1" EMT 10" FIXTURE HEIGHT
7	10035-37	1	SEAL
8	10H27-013D10	2	SCREW, RD. HD., #6-32 x 5/16 SELF-TAP TYPE "F" SST
9	10037-1025	1	LAMP 30W, 6.6A
	40732	1	LAMP 45W, 6.6A
10	50122-C(ML5411)	1	AVIATION GLOBE, CLEAR
	50122-CY(ML5412)	1	AVIATION GLOBE, CLEAR/YELLOW
	50122-R(ML2075)	1	AVIATION GLOBE, RED
	50122-B-45(ML331)	1	AVIATION GLOBE, BLUE 45W
	50122-B-30	1	AVIATION GLOBE, BLUE 30W
	50122-RY(ML5413)	1	AVIATION GLOBE, RED/YELLOW
	50122-Y(FL6477)	1	AVIATION GLOBE, YELLOW
	50122-XG	1	AVIATION GLOBE, BLANK/GREEN
	50122-RG(ML5413)	1	AVIATION GLOBE, RED/GREEN
	50122-CR(ML5571)	1	AVIATION GLOBE, CLEAR/RED
	50122-CG(ML5570)	1	AVIATION GLOBE, CLEAR/GREEN
50122-G(ML2572)	1	AVIATION GLOBE, GREEN	
11	50186	1	BREAKABLE COUPLING
12	10H29-025D20	3	SCREW, HEX HD., 1/4-20 x 5/8 SELF-TAP TYPE "F" SST
13	40749	1	SOCKET, BI-PIN
14	50107	1	CLAMP BAND
15	50020	1	LAMP TAG (45W)
	50020-1	1	LAMP TAG (30W)
16	NOT USED		
17	10000-442M	1	SCREW, #M6 X 12MM (INCLUDED WITH ITEMS 11 & 18)
18	50184	A/R	BREAKABLE COUPLING (-MC2 OPTION)

PART NUMBER ORDERING DATA

40938 - X - XX - XX - XX

PART NUMBER _____

BEAM COLOR _____

C = CLEAR R = RED
 B = BLUE Y = YELLOW
 G = GREEN X = OPAQUE/BLANK

LAMP WATTAGE _____
 00 = LAMP NOT INCLUDED
 30 = 30 WATT (NOT ETL CERTIFIED)
 45 = 45 WATT (ETL CERTIFIED)

OPTIONS

X = WITHOUT GLOBE
 MC2 = METALLIC BREAKABLE COUPLING (2" TH'D)

HEIGHT IN INCHES

10 = 10 INCH (NOT ETL CERTIFIED)
 14 = STANDARD
 (AVAILABLE IN 2 INCH INCREMENTS TO 30 INCHES)