

Champ Pro PFMA LED floodlights

9,000 to 15,000 lumens

UL/CSA Listed
Type 4X; IP67

5L

Our Champ Pro PFMA LED floodlight is a field-proven design that helps ensure safety, reliability and performance in harsh and heavy industrial areas. Champ products are engineered to deliver more operational value and better total cost of ownership.

Applications:

- For general area illumination of locations with mounting heights from 15 to 30 feet
- Locations requiring continuous and consistent light levels in extreme ambient temperatures
- Where extremely corrosive, wet, dusty, hot and/or cold conditions exist
- IP67, Type 4X, marine, wet locations and hose down environments
- Manufacturing plants; heavy industrial, chemical, food and beverage facilities; mining; platforms; loading docks; tunnels; outdoor wall and pole mounted areas

Standard materials:

- Lamp housing – die cast aluminum with Corro-free epoxy powder coat
- Lens – heat- and impact-resistant glass (standard); diffused glass or polycarbonate (optional)
- Gaskets – silicone
- External hardware – 316 stainless steel
- Factory sealed, no external seals required

LED system:

- High intensity discrete power emitters
- Cool white (5000K, 70 CRI) (standard); deep warm (2200K, 70 CRI), warm white (3000K, 80 CRI) or neutral white (4000K, 80 CRI) (optional)
- NEMA 7x6 or 4x4 optical patterns available
- Dimmable driver 0-10V
- Rated life of 60,000 hours continuous operation at 55°C operating ambient temperature
- 5 year fixture warranty



Photometrics:

- Refer to www.eaton.com (under the Resources tab of each product family) for specific photometric IES files

Certifications and compliances:

NEC/CEC:

- Marine and wet locations, Type 4X, IP67
- ABS
- Operating ambient temperature: -40°C to 65°C

UL standards:

- UL1598 – Luminaires; UL1598A – Marine; UL50E

CSA standard:

- C22.2 No. 250

FCC:

- FCC Part 15 / ICES-005 Ver. 5
CAN ICES-005 (A) / NMB-005 (A)



Electrical ratings:

| Model | Weight Lbs. (Kg.) | Nominal lumens | Efficacy ^A | Wattage | Voltage | Amps | Power factor | THD | Surge protection |
|--------------|-------------------|----------------|-----------------------|---------|-----------------------|-------------|--------------|-------|------------------|
| PFMA-9-UNV1 | 24.92 (11.30) | 9,261 | 162 lm/W | 58.12 | 100-277 VAC, 50/60 Hz | 0.59 - 0.22 | ≥ 0.90 | ≤ 20% | 6kV |
| PFMA-11-UNV1 | 24.92 (11.30) | 11,602 | 158 lm/W | 77.35 | 100-277 VAC, 50/60 Hz | 0.79 - 0.28 | ≥ 0.90 | ≤ 20% | 6kV |
| PFMA-13-UNV1 | 24.92 (11.30) | 13,581 | 154 lm/W | 89.60 | 100-277 VAC, 50/60 Hz | 0.91 - 0.32 | ≥ 0.90 | ≤ 20% | 6kV |
| PFMA-15-UNV1 | 24.92 (11.30) | 15,845 | 154 lm/W | 106.78 | 100-277 VAC, 50/60 Hz | 1.07 - 0.38 | ≥ 0.90 | ≤ 20% | 6kV |
| PFMA-9-UNV3 | 24.95 (11.32) | 9,261 | 162 lm/W | 58.34 | 347-480 VAC, 50/60 Hz | 0.17 - 0.12 | ≥ 0.90 | ≤ 20% | 6kV |
| PFMA-11-UNV3 | 24.95 (11.32) | 11,602 | 158 lm/W | 75.01 | 347-480 VAC, 50/60 Hz | 0.22 - 0.16 | ≥ 0.90 | ≤ 20% | 6kV |
| PFMA-13-UNV3 | 24.95 (11.32) | 13,581 | 154 lm/W | 90.38 | 347-480 VAC, 50/60 Hz | 0.26 - 0.19 | ≥ 0.90 | ≤ 20% | 6kV |
| PFMA-15-UNV3 | 24.95 (11.32) | 15,845 | 154 lm/W | 105.38 | 347-480 VAC, 50/60 Hz | 0.30 - 0.22 | ≥ 0.90 | ≤ 20% | 6kV |

^AConsult IES files for exact performance data.

Champ Pro PFMA LED floodlights

9,000 to 15,000 lumens

UL/CSA Listed
Type 4X; IP67

5L

INSTALLATION EASE

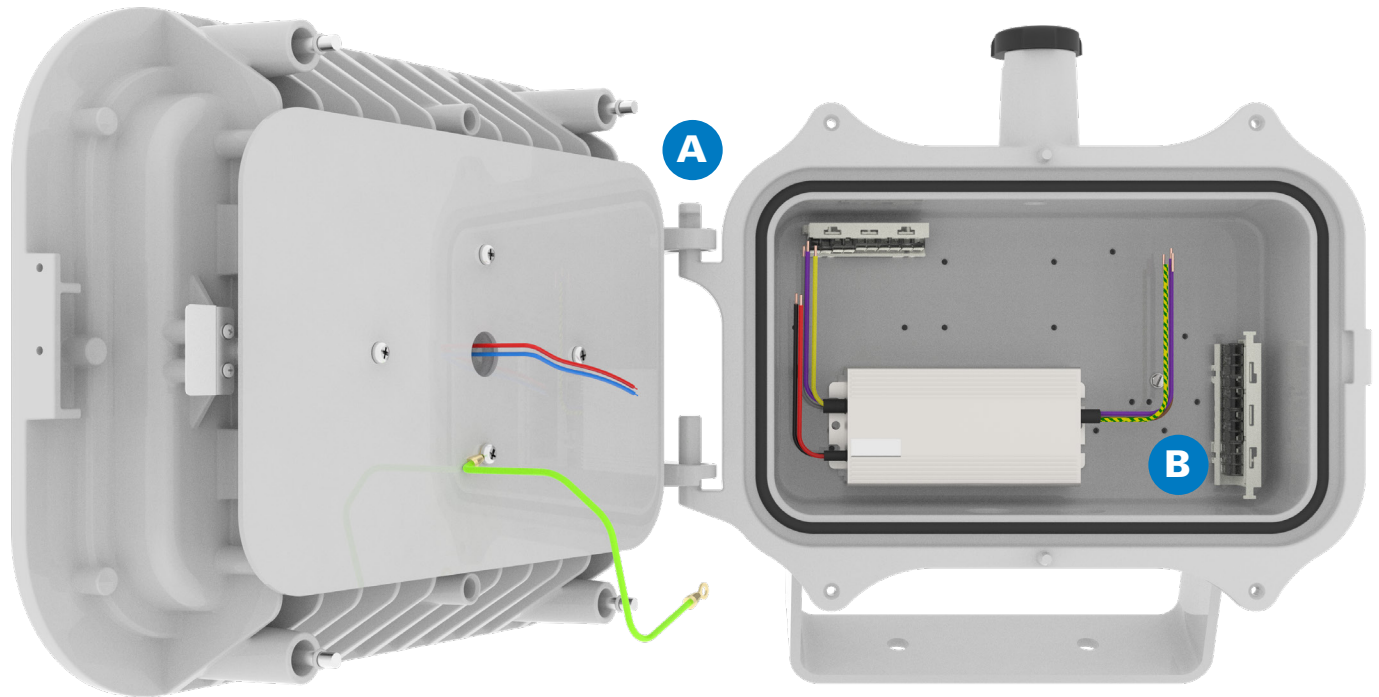

A Lightweight & easy access

- Driver and LED engine are field replaceable for extended life even beyond the warranty
- Removable cover for LED engine and hinged driver compartment enables faster installation, access to wiring and field maintenance
- 22% weight reduction from previous generation Champ floodlight models

B Now supports up to 10 AWG wire for easier, less costly retrofits!

- Customers with 10 AWG wire already running through their facility from older, higher power HID fixtures can reuse the same wiring
- Plug and play wiring helps speed installation

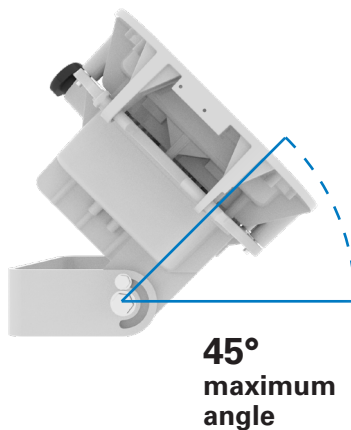
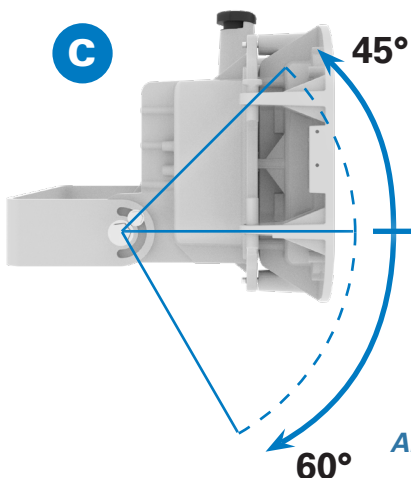
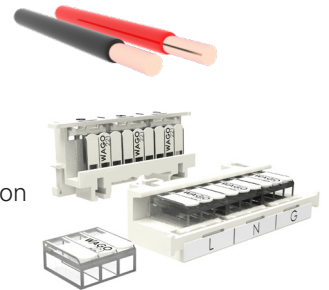

C Versatile mounting options

- Yoke mount and accessories help ensure the fixtures are installed in the correct location to properly light your facility

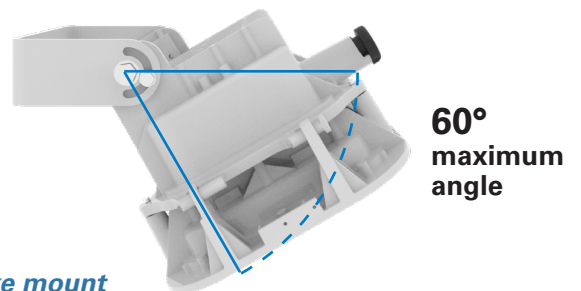

All units come standard with a yoke mount

Champ Pro PFMA LED floodlights

9,000 to 15,000 lumens

UL/CSA Listed
Type 4X; IP67

5L

RELIABLE PERFORMANCE

D Thermal management

- Heat fins help ensure proper air flow and facilitate dust shedding for effective heat dissipation and thermal management of LED engine and driver

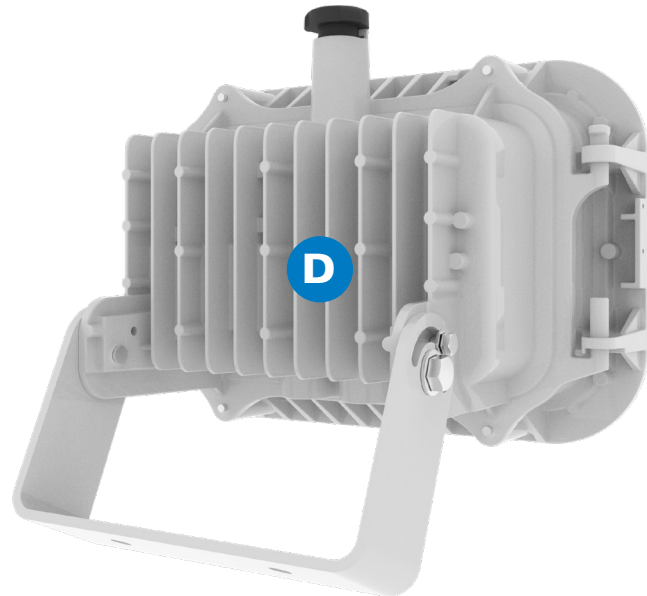

E Performance in extreme environments

- Operating ambient: -40°C to 65°C
- Type 4X, IP67
- 6kV surge protection
- Corrosion-resistant aluminum housing with Corro-free epoxy powder coating
- Vibration tested to withstand up to 3-axis 3G vibration
- Impact tested in accordance with Section 17.41 of UL1598



OPTIMIZED LIGHT & QUALITY

F Custom optics & colors

- Directs light where you need it, helping eliminate gaps and dark spots
- Can potentially reduce the number of light fixtures required in your application
- 2200K (deep warm), 3000K (warm), 4000K (neutral) and 5000K (cool) color options available



NEMA 4x4

Narrow uniform pattern for use at larger distances

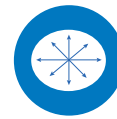

NEMA 7X6

Wide flood distribution provides a large and uniform light pattern



5000K (cool)

Crisp, bright white with a blue hue

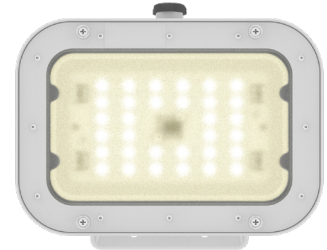

3000K (warm)

Soft, warm white with a yellow hue

G Multiple lens & epoxy powder coat options

- Clear glass lens (standard)
- Diffused glass and clear polycarbonate lenses optional
- Corro-free epoxy powder coat available in gray (standard); white or bronze optional



White



Gray



Bronze

Champ Pro PFMA LED floodlights

9,000 to 15,000 lumens

UL/CSA Listed
Type 4X; IP67

5L

Ordering information:

Part number example

PFMA-9-W-76-M20-DG-UNV1-WH-M2

PFMA - 9 - W - 76 - M20 - DG - UNV1 - WH - M2

Light source / intensity

| | |
|----|-----------------------|
| 9 | 9,261 nominal lumens |
| 11 | 11,602 nominal lumens |
| 13 | 13,581 nominal lumens |
| 15 | 15,845 nominal lumens |

Color temperature

| | |
|-----------------|-------------------------------|
| BLANK | 5000K, 70 CRI (cool white) |
| N [®] | 4000K, 80 CRI (neutral white) |
| W | 3000K, 80 CRI (warm white) |
| 22 [®] | 2200K, 70 CRI (deep warm) |

Beam pattern

| | |
|-----------------|----------|
| 76 | NEMA 7x6 |
| 44 [®] | NEMA 4x4 |

Entries

| | |
|-------|----------|
| BLANK | 3/4" NPT |
| M20 | 20mm |
| M25 | 25mm |

Lens material

| | |
|-----------------|--------------------------|
| BLANK | Clear glass lens |
| DG | Diffused glass lens |
| PC [®] | Clear polycarbonate lens |

Voltage

| | |
|------|-----------------------|
| UNV1 | 100-277 VAC, 50/60 Hz |
| UNV3 | 347-480 VAC, 50/60 Hz |

Epoxy powder coat

| | |
|-----------------|--------|
| BLANK | Gray |
| WH [®] | White |
| BZ [®] | Bronze |

Accessories (ordered separately):

Description

- Bull horn, 2 tenon, gray **BLHN2**
- Bull horn, 2 tenon, bronze **BLHN-BZ2[®]**
- Bull horn, 2 tenon, white **BLHN-WH2[®]**
- Bull horn, 3 tenon, gray **BLHN3**
- Bull horn, 3 tenon, bronze **BLHN-BZ3[®]**
- Bull horn, 3 tenon, white **BLHN-WH3[®]**

Description

- Safety cable **SC831**
- Floodlight slipfitter **SFA6**
- Slipfitter wall mount adapter **SWB6**

Replacement driver kits (ordered separately)

| | |
|-----------------------------------|--|
| FMVA-9-UNV1-M2-DRIVER KIT | UNV1 M2 replacement driver kit for PFMA-9 |
| FMVA-11-UNV1-M2-DRIVER KIT | UNV1 M2 replacement driver kit for PFMA-11 |
| FMVA-13-UNV1-M2-DRIVER KIT | UNV1 M2 replacement driver kit for PFMA-13 |
| FMVA-15-UNV1-M2-DRIVER KIT | UNV1 M2 replacement driver kit for PFMA-15 |
| FMVA-9-UNV3-M2-DRIVER KIT | UNV3 M2 replacement driver kit for PFMA-9 |
| FMVA-11-UNV3-M2-DRIVER KIT | UNV3 M2 replacement driver kit for PFMA-11 |
| FMVA-13-UNV3-M2-DRIVER KIT | UNV3 M2 replacement driver kit for PFMA-13 |
| FMVA-15-UNV3-M2-DRIVER KIT | UNV3 M2 replacement driver kit for PFMA-15 |

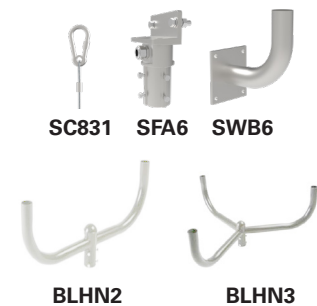

[®]Contact factory for lead time.

Champ Pro PFMA LED floodlights

9,000 to 15,000 lumens

UL/CSA Listed
Type 4X; IP67

5L

Dimensions – standard yoke mount:

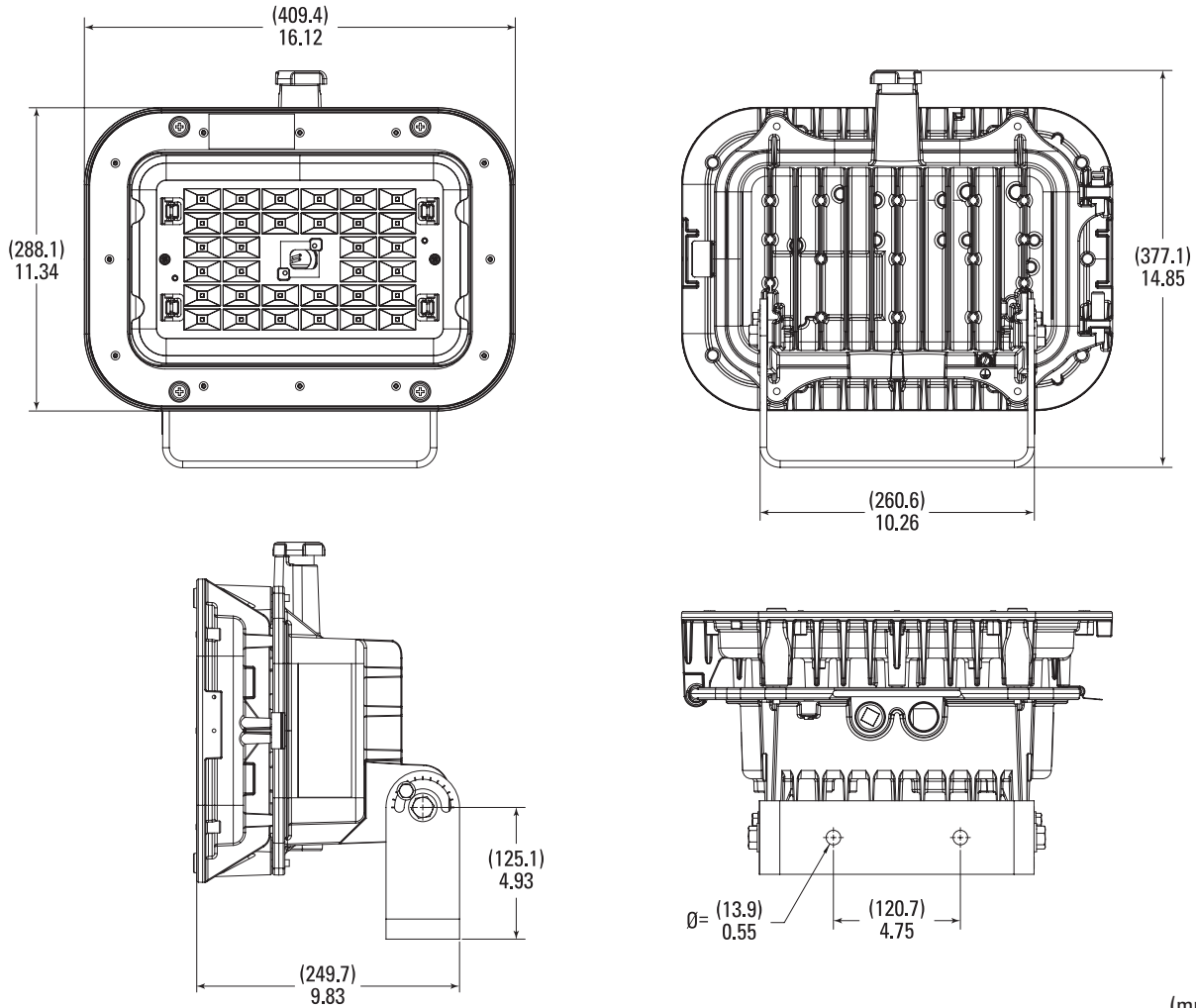

(mm)
All dimensions: inches

| Mounting method | Angle range | Mounting surface |
|-----------------|--------------|--|
| Yoke (standard) | +45° to -60° | Wall, ceiling, horizontal surface/ground |

5L