

# Pauluhn Achiever QC and QL dusttight floodlights

Type 4  
Conforms to IP66

6L

## Applications:

- Onshore drilling and exploration<sup>A</sup>
- Dusttight requirements
- Pulp and paper production<sup>A</sup>
- Emergency evacuation
- Vehicle accessory lighting
- General industrial area lighting
- Security lighting

## Features:

- 500W quartz halogen
- Heavy duty C-clamp design (QC models only); single latch design (QL models only)
- High temperature silicone gasket provides a watertight seal
- Cast aluminum finned housing for greater heat dissipation
- Separate wire connection box for ease of wiring<sup>A</sup>
- Hinged door for easy lamp replacement and maintenance
- Thermal shock-resistant, tempered ¼" thick glass lens
- Double spring loaded sockets extend lamp life in vibration areas
- Wide NEMA 6x6 beam spread
- Protective guard available

## Certifications and compliances:

- UL1598 – Luminaires
- CSA Class 3425 03
- CSA Class 3425 83
- Enclosed and gasketed
- Type 4
- Conforms to IP66
- ABS

## Standard materials and finishes:

- Housing and lens frame – cast aluminum
- Lens – tempered ¼" thick glass
- Gasket – one-piece silicone
- Optional guard – Type 18/8 stainless steel
- Mounting brackets – aluminum
- Reflector – highly specular aluminum
- Hardware – plated steel



QC

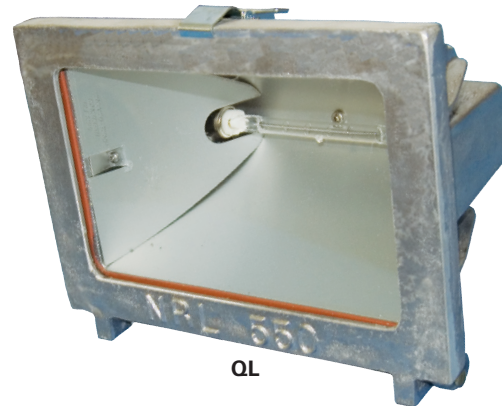

QL

## Technical specifications:

- Entries – one ½" NPT
- Wind rating – EPA: <1 at vertical
- Lamp type – T3 quartz halogen (lamps provided)
- Lamp holder – double spring loaded
- Voltage – 120V; 220V (optional)

## Mounting options:

- Trunnion mount
- Post top mount

## Photometrics:

- Complete photometrics can be found at [www.crouse-hinds.com/photometrics](http://www.crouse-hinds.com/photometrics)

<sup>A</sup>Applicable for QC models only.

# Pauluhn Achiever QC and QL dusttight floodlights

Type 4  
Conforms to IP66

6L

## Options:

- | Description                               | Suffix                |
|---|-----------------------|
| • Post top mount (replace suffix T) ..... | <b>P</b>              |
| • Stainless steel wire guard .....        | <b>WG<sup>Ⓟ</sup></b> |

## Ordering information:

Cat. #	Lamp type	Watts	Voltage	Weight (lbs.)	ANSI lamp type	Ambient temperature °C	Supply wire °C
QAC511T	Quartz halogen	500	120V	9.5	T-3 RSC	25	90
QAC512T	Quartz halogen	500	240V	9.5	T-3 RSC	25	90
QAL501T	Quartz halogen	500	120V	8.5	T-3 RSC	25	90
QAL502T	Quartz halogen	500	240V	8.5	T-3 RSC	25	90

## Dimensions (in inches):

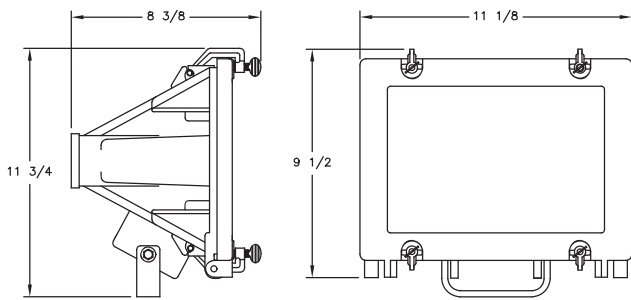

QA-C trunnion mount

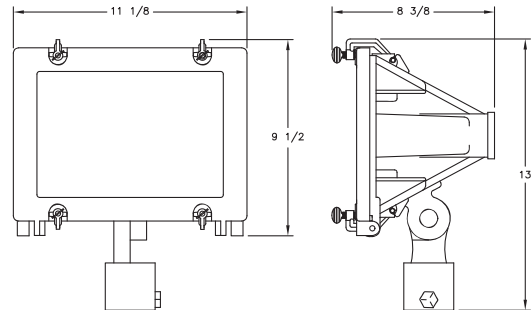

QA-C post mount

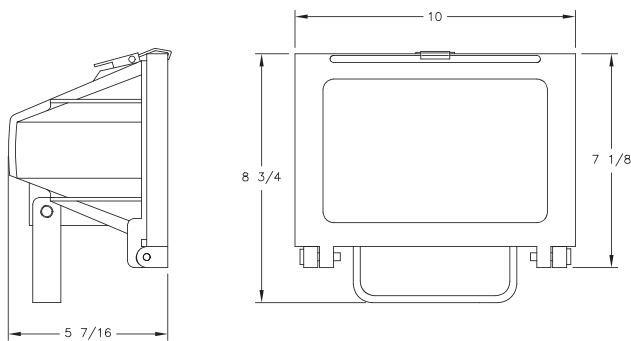

QA-L trunnion mount

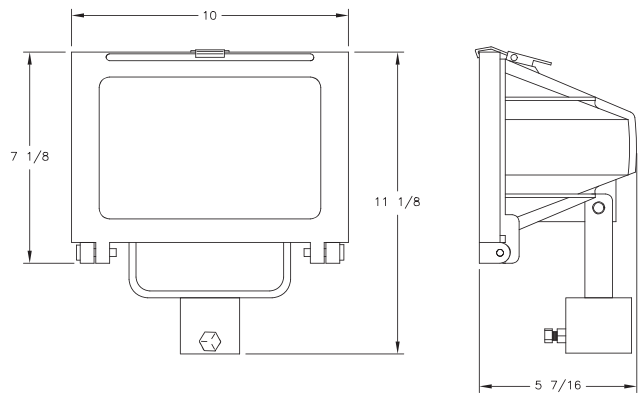

QA-L post mount

<sup>Ⓟ</sup> Cannot be field installed; specify at order placement.

6L