

XN300 switch XN-332-5ETH-UMS

Instruction manual



EATON

Powering Business Worldwide

DISCLAIMER OF WARRANTIES AND LIMITATION OF LIABILITY

The information, recommendations, descriptions and safety notations in this document are based on Eaton Corporation's ("Eaton") experience and judgment and may not cover all contingencies. If further information is required, an Eaton sales office should be consulted. Sale of the product shown in this literature is subject to the terms and conditions outlined in appropriate Eaton selling policies or other contractual agreement between Eaton and the purchaser.

THERE ARE NO UNDERSTANDINGS, AGREEMENTS, WARRANTIES, EXPRESSED OR IMPLIED, INCLUDING WARRANTIES OF FITNESS FOR A PARTICULAR PURPOSE OR MERCHANTABILITY, OTHER THAN THOSE SPECIFICALLY SET OUT IN ANY EXISTING CONTRACT BETWEEN THE PARTIES. ANY SUCH CONTRACT STATES THE ENTIRE OBLIGATION OF EATON. THE CONTENTS OF THIS DOCUMENT SHALL NOT BECOME PART OF OR MODIFY ANY CONTRACT BETWEEN THE PARTIES.

In no event will Eaton be responsible to the purchaser or user in contract, in tort (including negligence), strict liability or otherwise for any special, indirect, incidental or consequential damage or loss whatsoever, including but not limited to damage or loss of use of equipment, plant or power system, cost of capital, loss of power, additional expenses in the use of existing power facilities, or claims against the purchaser or user by its customers resulting from the use of the information, recommendations and descriptions contained herein. The information contained in this manual is subject to change without notice.

Contents

SAFETY INFORMATION	IV
Hazard statement definitions	iv
Safety instructions	iv
ABOUT THIS MANUAL	VI
List of revisions	vi
Target group	vi
Legal disclaimer	vi
Device designations and abbreviations	vi
Writing conventions	vi
XN300 SWITCH XN-332-5ETH-UMS	1
Proper use	1
Overview of functions	1
Versions	1
Ethernet connections	2
LED status indicators	2
Potential relationship between the components	2
INSTALLATION	3
Mounting XN-332-5ETH-UMS	3
Dismantling XN-332-5ETH-UMS	4
Connection terminals	5
Connecting the power supply	6
APPENDIX	7
Approvals and national approvals for XN300 system devices	7
Dimensions	7
Technical data	8
Further reading and links	8

Safety information

The instructions in this manual are not intended as a substitute for proper training or adequate experience in the safe operation of the equipment described. Only competent technicians who are familiar with this equipment should install, operate, and service it.

A competent technician has these qualifications:

- Is thoroughly familiar with these instructions
- Is trained in industry-accepted high- and low-voltage safe operating practices and procedures
- Is trained and authorized to energize, de-energize, clear, and ground power distribution equipment
- Is trained in the care and use of protective equipment such as arc flash clothing, safety glasses, face shield, hard hat, rubber gloves, clampstick, hotstick, etc.

Following is important safety information. For safe installation and operation of this equipment, be sure to read and understand all cautions and warnings.

Hazard statement definitions

This manual may contain four types of hazard statements.

⚠ DANGER
INDICATES AN IMMINENTLY HAZARDOUS SITUATION WHICH, IF NOT AVOIDED, WILL RESULT IN DEATH OR SERIOUS INJURY.

⚠ WARNING
INDICATES A POTENTIALLY HAZARDOUS SITUATION WHICH, IF NOT AVOIDED, COULD RESULT IN DEATH OR SERIOUS INJURY.

⚠ CAUTION
INDICATES A POTENTIALLY HAZARDOUS SITUATION WHICH, IF NOT AVOIDED, MAY RESULT IN MINOR OR MODERATE INJURY.

NOTICE
INDICATES A POTENTIALLY HAZARDOUS SITUATION WHICH, IF NOT AVOIDED, MAY RESULT IN EQUIPMENT DAMAGE ONLY.

Safety instructions

Following are general caution and warning statements that apply to this equipment. Additional statements, related to specific tasks and procedures, are located throughout the manual.

⚠ DANGER
HAZARDOUS VOLTAGE. CONTACT WITH HAZARDOUS VOLTAGE WILL CAUSE DEATH OR SEVERE PERSONAL INJURY. FOLLOW ALL LOCALLY APPROVED SAFETY PROCEDURES WHEN WORKING AROUND HIGH- AND LOW-VOLTAGE LINES AND EQUIPMENT.

⚠ WARNING
BEFORE INSTALLING, OPERATING, MAINTAINING, OR TESTING THIS EQUIPMENT, CAREFULLY READ AND UNDERSTAND THE CONTENTS OF THIS MANUAL. IMPROPER OPERATION, HANDLING, OR MAINTENANCE CAN RESULT IN DEATH, SEVERE PERSONAL INJURY, AND EQUIPMENT DAMAGE.

⚠ WARNING
THIS EQUIPMENT IS NOT INTENDED TO PROTECT HUMAN LIFE. FOLLOW ALL LOCALLY APPROVED PROCEDURES AND SAFETY PRACTICES WHEN INSTALLING OR OPERATING THIS EQUIPMENT. FAILURE TO COMPLY CAN RESULT IN DEATH, SEVERE PERSONAL INJURY, AND EQUIPMENT DAMAGE.

⚠ WARNING
POWER DISTRIBUTION AND TRANSMISSION EQUIPMENT MUST BE PROPERLY SELECTED FOR THE INTENDED APPLICATION. IT MUST BE INSTALLED AND SERVICED BY COMPETENT PERSONNEL WHO HAVE BEEN TRAINED AND UNDERSTAND PROPER SAFETY PROCEDURES. THESE INSTRUCTIONS ARE WRITTEN FOR SUCH PERSONNEL AND ARE NOT A SUBSTITUTE FOR ADEQUATE TRAINING AND EXPERIENCE IN SAFETY PROCEDURES. FAILURE TO PROPERLY SELECT, INSTALL, OR MAINTAIN POWER DISTRIBUTION AND TRANSMISSION EQUIPMENT CAN RESULT IN DEATH, SEVERE PERSONAL INJURY, AND EQUIPMENT DAMAGE.

⚠ WARNING
OVERLAPPING ZONES OF PROTECTION ARE REQUIRED. UPSTREAM PROTECTION DEVICE SETTINGS MUST PROVIDE ADEQUATE OVERCURRENT PROTECTION IN THE EVENT OF A SYSTEM OR PRODUCT FAILURE. FAILURE TO PROPERLY SELECT APPROPRIATE UPSTREAM COORDINATION PROTECTION CAN RESULT IN DEATH, SERIOUS INJURY, AND EQUIPMENT DAMAGE.

This manual contains important information regarding the operation and installation of the Active Voltage Conditioner. All operations on the Active Voltage Conditioner should be carried out by a trained technician familiar with the contents of this manual.

Before starting with the installation

- De-energize the device
- Secure against retriggering
- Verify isolation from the supply
- Ground and short-circuit
- Cover or enclose any neighboring live parts
- Follow the mounting instructions (AWA/IL) for the device
- Only suitably qualified personnel in accordance with EN 50 110-1/-2 (VDE 0105 Part 100) may work on this device/system
- Before installation and before touching the device, ensure that you are free of electrostatic charge
- The functional earth (FE) must be connected to the protective earth (PE) or to the equipotential bonding. The system installer is responsible for implementing this connection
- Connecting cables and signal lines should be installed in such a way that inductive and capacitive interference will not have a negative impact on the automation functions
- Install automation devices and related operating elements in such a way that they are well protected against unintentional operation
- Suitable safety hardware and software measures should be implemented for the I/O interface so that cable or wire breakage on the signal side will not result in undefined states in the automation devices
- Ensure a reliable electrical isolation of the low voltage for the 24 V supply; only use power supply units complying with IEC 60364-4-41 or HD 384.4.41 S2 (VDE 0100 Part 410)
- Deviations of the mains voltage from the nominal value must not exceed the tolerance limits given in the specifications, otherwise this may result in malfunction and hazardous states
- Emergency stop devices complying with IEC/EN 60204-1 must remain functional in all of the automation devices' operating modes; unlatching the emergency stop devices must not result in an automatic restart
- Built-in devices for enclosures or cabinets must only be run and operated in an installed state; desktop devices and portable devices only when the housing is closed
- Measures should be taken to ensure the proper restarting of programs interrupted after a voltage dip or outage. This should not result in dangerous operating states even for a short time; if necessary, emergency stop devices should be implemented
- Wherever faults in the automation system may cause damage to persons or property, external measures must be implemented to ensure a safe operating state in the event of a fault or malfunction (for example, by means of separate limit switches, mechanical interlocks, etc.)

About this manual

About this manual

This manual describes the installation and commissioning of the XN300 switch XN-332-5ETH-UMS.

Support center

The latest version of this manual can be found in other languages by visiting our support center at: <http://www.eaton.eu/documentation>.

Enter the search keyword **XN300** into the quick search or enter the document designation, e.g., MN050011.

List of revisions

This is the first version of this document, meaning there are no changes.

Target group

This manual is intended for automation technicians and engineers.

Extensive knowledge of how to work with the field bus being used will make it easier to understand the contents of this manual.

A specialist knowledge of electrical engineering is needed for commissioning and programming.

Legal disclaimer

All information in this operator manual was provided by us to the best of our knowledge and belief and in accordance with the current state-of-the-art. However, this does not exclude the possibility of inaccuracies so that we cannot accept any liability for the accuracy and completeness of the information. In particular, this information does not guarantee any particular properties.

The devices described here must only be set up and operated as specified in this manual and in the installation instructions provided with the device. Installation, commissioning, operation, maintenance, and refitting of the devices must only be carried out by qualified persons. The devices must only be used in the areas recommended and only in conjunction with third-party devices and components that have been approved by us. Only devices and components that are in technically faultless conditions are permitted. Fault-free and safe operation of the system requires proper transport, storage, installation, and commissioning, as well as careful operation and maintenance. If the following safety instructions are not observed, particularly with regard to commissioning and maintenance of the devices by insufficiently qualified personnel and/or in the event of improper use of the devices, any hazards caused by the devices cannot be excluded. We assume no liability for any injury or damages incurred.

Device designations and abbreviations

XN300 device series, including the XN-312 gateways and XN300 slice modules.

Writing conventions

Symbols used in this manual have the following meanings:

⚠ DANGER
WARNS OF HAZARDOUS SITUATIONS THAT RESULT IN SERIOUS INJURY OR DEATH.

⚠ CAUTION
WARNS OF THE POSSIBILITY OF HAZARDOUS SITUATIONS THAT COULD RESULT IN SLIGHT INJURY OR EVEN DEATH.

NOTICE
WARNS ABOUT THE POSSIBILITY OF MATERIAL DAMAGE.

XN300 switch XN-332-5ETH-UMS

Proper use

The XN300 switch XN-332-5ETH-UMS is an integral part of the XN300 system. It can be used to connect multiple network segments with its five ports and have the data packets coming into one of five Ethernet ports (X1–X5) be distributed to the other ports.

Power supply and signal terminals must be protected against accidental contact and covered.

The XN300 system may only be operated if it has been correctly fitted and connected by qualified electrical specialists. The installation must comply with regulations for electromagnetic compatibility (EMC).

⚠ DANGER

COMMISSIONING THE XN300 SYSTEM DEVICES AND SWITCHING THEM ON MUST NOT RESULT IN ANY HAZARDS BEING POSED BY THE DEVICES BEING DRIVEN, E.G., UNEXPECTED MOTOR STARTUPS AND EQUIPMENT BECOMING UNEXPECTEDLY ENERGIZED.

Overview of functions

The XN-332-5ETH-UMS XN300 switch features the same design as the other devices in the XN300 system.

The aforementioned XN300 system includes XN300 slice modules in the form of I/O modules and speciality modules, as well as gateways such as the XN-312-GW-CAN and XN-312-GW-EC.

The XN-332-5ETH-UMS is an unmanaged switch without a system bus and is accordingly snapped onto the top hat DIN rail as a standalone device.

NOTICE

DO NOT ATTEMPT TO INSTALL THE XN-332-5ETH-UMS WITHIN AN XN300 SYSTEM BLOCK.

Power is provided via a 24 Vdc power input at the top of the device.

Versions

The XN300 switch is housed in a double-width case. Power is supplied from above through a 4-pin FMC 1.5/4-ST-3.5 connector.

Figure 1. XN-332-5ETH-UMS front view

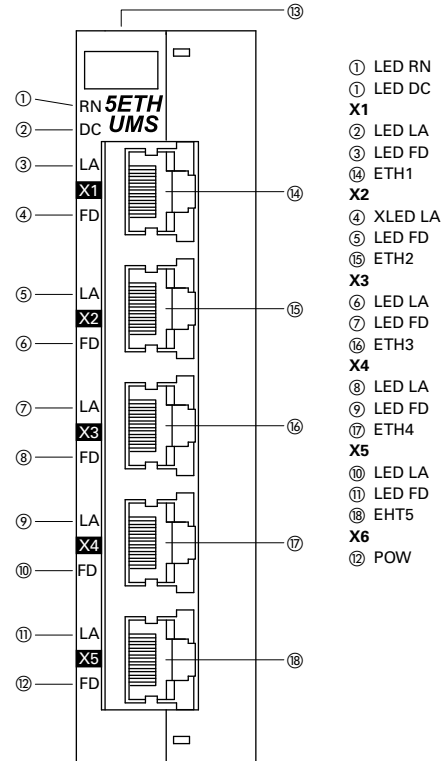

Ethernet connections

The XN-332-5ETH-UMS can be used to connect multiple network segments (ETH1–ETH5) using the five RJ45 ports (X1–X5). Each of these ports features an LA (Link Active) LED that signals the port’s connection status and an FD (Full Duplex) LED that shows which data transfer mode is currently selected. The data transfer rate for the XN300 10/100BASE-T Ethernet switch is set automatically depending on the data transfer rate required by the device with which it is currently communicating: 10 Mbit/s in half-duplex mode or 100 Mbit/s (Fast Ethernet) in full-duplex mode.

The maximum distance per network segment is 100 m.

X1...X5	Pin	Function
8	1	Tx+/Rx+
7	2	Tx-/Rx-
6	3	Rx+/Tx+
5	4, 5	—
4	6	RX-/Tx-
3	7, 8	—
2		
1		

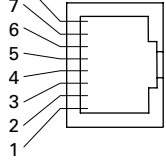

LED status indicators

The device’s status LEDs are located underneath the front cover and can be seen underneath the corresponding labels when they light up.

Table 1. LED meanings

LED	Color	EtherCAT status	Description
RN (run)	Yellow	Continuous light	The XN300 switch is in the RUN state and is ready for operation.
	AUS	–	The XN300 switch is not ready for operation.
DC (direct current)	Green	Continuous light	Power supply OK.
	AUS	–	Voltage below the permissible limit.
LA (Ethernet link active)	Green	Continuous light	Connection between two PHYs established.
		Flashes	Data is being received or transmitted through the Ethernet bus.
	AUS	–	INIT
FD (Ethernet full duplex)	Yellow	Continuous light	Port working in full-duplex mode.
	AUS	–	Port working in half-duplex mode.

Potential relationship between the components

The XN-332-5ETH-UMS features a contact point that is used to establish a functional earth connection to the DIN rail. The supply voltage’s ground connection is connected to this functional earth.

Common

- 0 V
- 

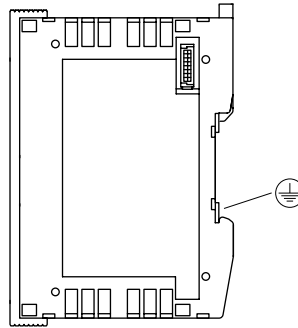

Installation

⚠ DANGER

ALL INSTALLATION WORK MUST BE CARRIED OUT WITH THE ENTIRE INSTALLATION IN A DE-ENERGIZED STATE.

ALWAYS FOLLOW THE SAFETY RULES:

- DE-ENERGIZE AND ISOLATE THE SYSTEM.
- VERIFY ISOLATION FROM THE SUPPLY.
- SECURE AGAINST RESTART.
- SHORT-CIRCUIT AND GROUND.
- COVER ADJACENT LIVE PARTS.

Mounting XN-332-5ETH-UMS

Install the XN300 switch XN-332-5ETH-UMS in a control panel, a distribution board, or an enclosure so that the power supply and terminal capacities cannot be touched accidentally during operation. Mount the XN-332-5ETH-UMS on an EN/IEC 60715 DIN rail.

The DIN rail must establish a conductive connection to the control panel's back plate. The individual modules need to be mounted side by side on the DIN rail and then secured in place by closing the locking elements. Please note that all the devices must be installed in a horizontal position (module designation on top).

In order to ensure that the maximum operating ambient temperature will not be exceeded, make sure that there is enough clearance between the system block's vents and any neighboring components, as well as between the vents and the control panel's back plate.

Figure 2. The XN300 slice modules must be installed in a horizontal position

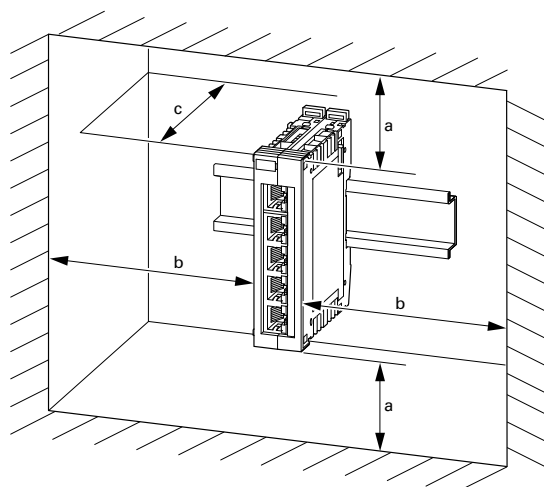

Dimensions in inches (mm)

a	b	c	ø
1.18 (30.0)	1.18 (30.0)	3.94 (100.0)	≤ 55 °C (≤ 131 °F)

The XN-332-5ETH-UMS can be mounted onto the top hat DIN rail by snapping it into place. To mount the system block, follow the steps below:

Step 1. Pull the locking elements at the back of the XN-332-5ETH-UMS upward. You can use a screwdriver to do this.

Figure 3. Securing the device on the DIN rail

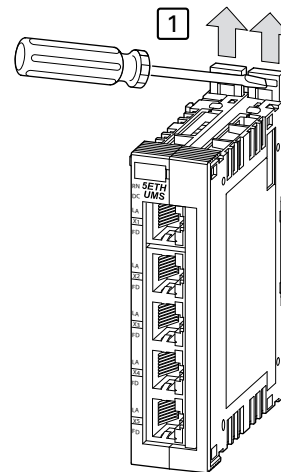

Step 2. Wire X6 connector as specified in chapter section "Connecting the power supply", page 5.

Step 3. Plug the X6 connector into the socket at the top of the device.

Figure 4. Connecting the power supply

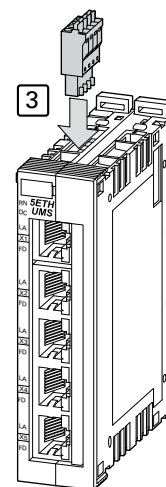

Installation

Step 4. Tilt XN-332-5ETH-UMS forward and place it against the DIN rail's bottom edge in an inclined position.

Step 5. Push the XN-332-5ETH-UMS over the DIN rail's top edge.

Figure 5. Place the XN-332-5ETH-UMS against the bottom edge of the DIN rail

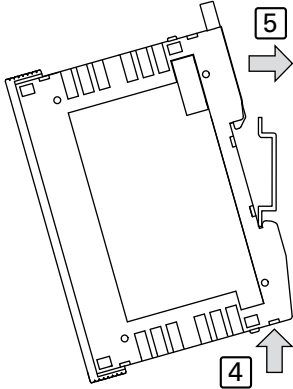

Step 6. Push the locking elements on the back of the XN-332-5ETH-UMS downward in order to secure the modules. You can use a screwdriver to do this.

Figure 6. Locking the XN-332-5ETH-UMS into place on the DIN rail

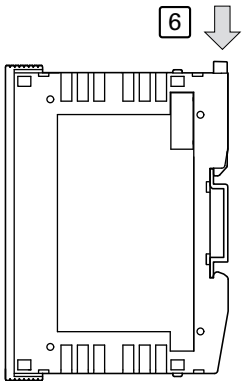

Step 7. Check to make sure that the XN-332-5ETH-UMS is solidly mounted.

Dismantling XN-332-5ETH-UMS

To remove the XN-332-5ETH-UMS, follow the steps below:

Step 1. Slide the locking elements on the back of the XN-332-5ETH-UMS upward. You can use a screwdriver to do this.

Figure 7. Disengaging the XN-332-5ETH-UMS

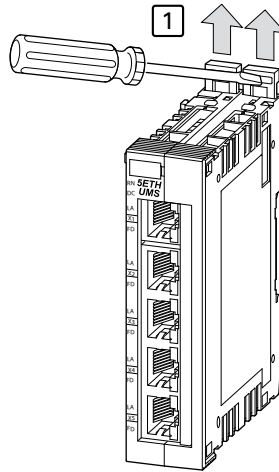

Step 2. Tilt the XN-332-5ETH-UMS forward, and then pull the block from its bottom edge, away from the DIN rail.

Figure 8. Place the XN-332-5ETH-UMS against the bottom edge of the DIN rail

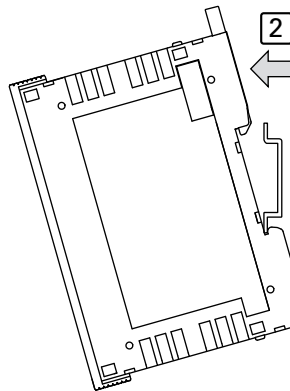

Step 3. Make sure that the device is de-energized.

Step 4. Pull connector X6 out from the female connector at the top in order to disconnect the device from the power supply.

Figure 9. Disconnecting the device from the power supply

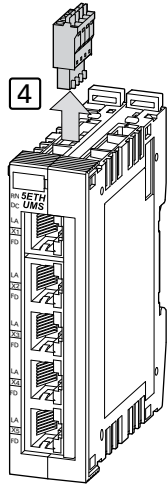

Connection terminals

Plug connector

X6: The required plug connector with push-in spring-cage terminals FMC 1.5/4-ST-3.5 is included as standard with the XN-332-5ETH-UMS. To use them, the conductor simply needs to be slid into the appropriate contact.

In order to release the conductor, simply press on the release mechanism, e.g., with a screwdriver, to pull out the conductor from the corresponding contact.

Table 2. Connection specifications



Cable cross-sectional areas		XN-332-...	
0.39 inch (10 mm)	Solid	mm ²	0.2–1.5
			
0.39 inch (10 mm)	Flexible with uninsulated ferrule	mm ²	0.2–1.5
			
0.39 inch (10 mm)	Flexible with insulated ferrule	mm ²	0.2–0.75
	Ferrule d	mm	≤ 2.8
	AWG		24–16
	Strip length	mm	10

Figure 10. Ferrule with d2 = Maximum 2.8 mm



NOTICE

THE SPRING-CAGE TERMINALS CAN BE USED TO CONNECT ULTRASONICALLY SPLICED (ULTRASONICALLY WELDED) WIRES.

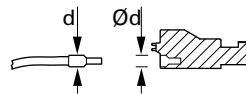
Installation

Connecting the power supply

⚠ DANGER

IN SAFETY-RELEVANT APPLICATIONS, THE POWER SUPPLY USED TO POWER THE XN300 SYSTEM MUST BE A PELV POWER SUPPLY UNIT.

The two 24 V V+ terminals are internally connected to each other (X6: ① and ②), as are the two 0 V GND terminals (X6: ③ and ④). Only one V+ and one 0 V terminal need to be connected in order to power the gateway. The internally connected terminals can be used to extend the 24 V and 0 V supply voltage connections. However, it is necessary to make sure that a total current of 4 A is not exceeded per terminal.

External 24 Vdc voltages can also be distributed using an XN-322-4PS-20 power distribution module or XN-322-18PD-P and XN-322-18PD-M field potential distributor modules.

The plug connector with push-in spring-cage terminal FMC 1.5/4-ST3.5 is included in the scope of supply.

Figure 11. Connection of power supply

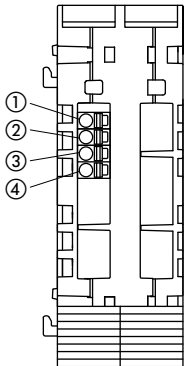

- ① 24 V V+
- ② 24 V V+
- ③ 0 V GND
- ④ 0 V GND

The device must be powered with a galvanically isolated power supply with a rated voltage of 24 Vdc. A UL® 249 fuse (maximum 4 A) must be installed between the power supply and the device.

Figure 12. Wiring the power supply

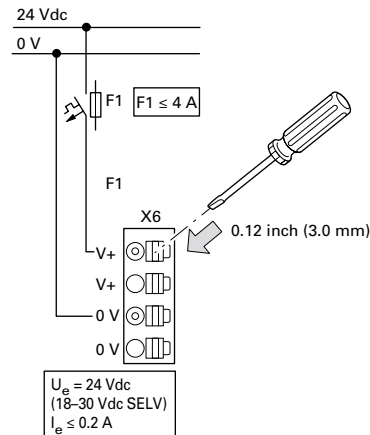

Appendix

Approvals and national approvals for XN300 system devices

XN300 system devices are approved for use in several countries and regions.

Description	Standard
Product standards	IEC/EN UL 508 (industrial control equipment) CE-mark
UL file no.	XN-332-5ETH-UMS: E135462 XN-312-..., XN-322-...: E135462
NA certification	cULus
Protection type	IEC: IP20

Dimensions

All XN300 system devices have the exact same dimensions.

Description	Specification
Dimensions W x H x D	mm 25 x 101.8 x 72
	inch 0.98 x 4.01 x 2.83
Weight	g 79
	lb 0.17
Mounting	Snapped onto IEC/EN 60715 DIN rail
Mounting position	Horizontal

Figure 13. Dimensions XN300 switch
XN-332-5ETH-UMS—dimensions in inches (mm)

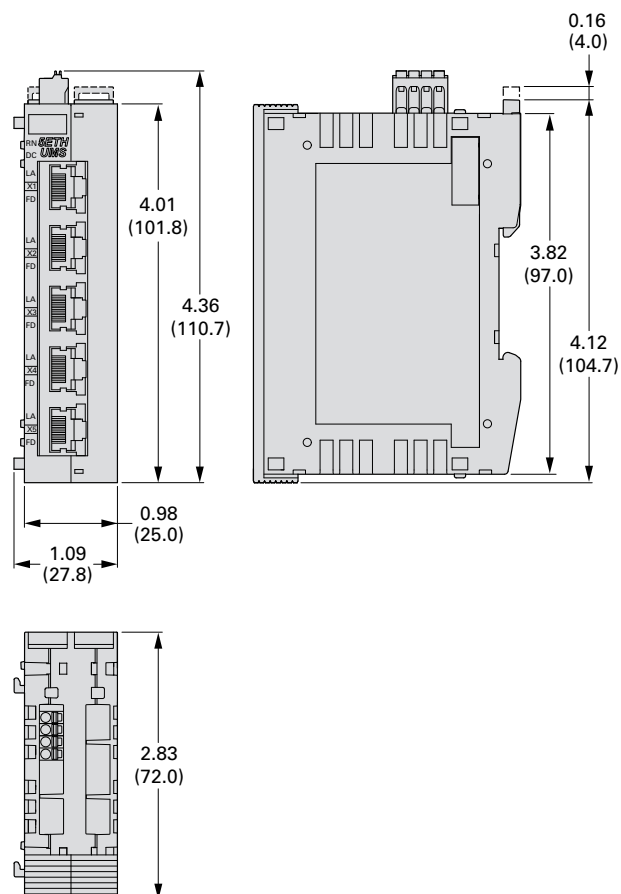

Technical data

Ambient conditions

Description	Specification
Storage temperature	-20 to +85 °C
Operating ambient temperature	0 to +55 °C
Humidity	0–95 %, noncondensing
EMC interference immunity	As per EN 61000-6-2 (industrial environment)
EMC emitted interference	As per EN 61000-6-4 (industrial environment)
Vibration resistance	EN 60068-2-6 3.5 mm of 5–8.4 Hz 1 g of 8.4–150 Hz
Mechanical shock resistance	EN 60068-2-27 15 g
Protection type	EN 60529 IP20



Power supply

Specifications for connection to supply voltage

Specifications for connection to supply voltage	Ue	V	18–30 V ⊕ DC
Residual ripple of input voltage	%	≤	5
Protection against polarity reversal		No	
Overload proof		Yes	
Supply current X6 (typ.)		200	mA

⊕ The device must be powered with a galvanically isolated power supply with a rated voltage of 24 Vdc. A UL 249 fuse (maximum 4 A) must be installed between the power supply and the end device.

Cable cross-sections

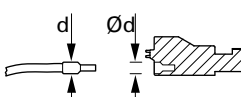
Cable cross-sectional areas	XN-332-...		
0.39 inch (10 mm) 	Solid	mm ²	0.2–1.5
0.39 inch (10 mm) 	Flexible with uninsulated ferrule	mm ²	0.2–1.5
0.39 inch (10 mm) 	Flexible with insulated ferrule	mm ²	0.2–0.75
	Ferrule d	mm	≤ 2.8
	AWG		24–16
	Strip length	mm	10

Additional information

General	XN-332-...
Imprintable label	MF 10/5 CABUR MC NE WS (Weidmüller)

Further reading and links

For more information on additional devices and modules, please visit the following links.

Product information

For up-to-date information, please consult the product page:

Eaton.de/xn300

Download Center—documentation

You can find the documents on the Download Center documentation page by entering the document name.

<http://www.eaton.eu/documentation>

File type	Title	Designation
Mounting instruction	XN-332-5ETH-UMS	IL050026ZU
Mounting instruction	XN-312-GW-CAN	IL050017ZU
Mounting instruction	XN-312-GW-EC	IL050025ZU
Mounting instruction	XC300	IL050018ZU
Manual	XN-312-GW-CAN	MN050003
Manual	XN-312-GW-EC	MN050010
Manual	XN300 slice modules	MN050002
Manual	XC300	MN050005



Eaton
1000 Eaton Boulevard
Cleveland, OH 44122
United States
Eaton.com

© 2022 Eaton
All Rights Reserved
Printed in USA
Publication No. MN050011EN / Z26444
August 2022

Eaton is a registered trademark.

All trademarks are property
of their respective owners.