

# Water-/Wastewater pumps

Application support for DG1





## Controlling water, everywhere it goes

Moving water and controlling water systems is no easy task. There are many variables involved with fluid dynamics, the addition of environmental, harmonics and energy cost concerns make system control even more difficult.

Eaton understands these problems and provides drives solutions for water/wastewater.



### Robust

- IP54 designs provide increased environmental protections
- Best-in-Class ambient temperature range from -30 °C up to +60 °C
- Conformal coated boards protect against aggressive ambient
- Multiple cooling fan operation modes designed to extend fan life and reduce maintenance

### Fast

- 18 basic parameters, quick start wizard and PC tools for simpler commissioning

### Simple

- Pre-configured applications to simplify complex parameter sets, from standard to multi-pump configurations
- Full text LCD keypad featuring copy/paste functionality and soft keys for faster navigation

### Service & support

- Standard two-year warranty with extensions available through certified commissioning
- Dedicated team of application engineers and technical resources available to provide pre-sales and after-sales support
- Aftermarket program providing spare parts, service and training classes

### Application control

- **MPC - Runtime control** – Alternating pump sequence to keep run time equal across the system.
- **MPC - Single master** – Provide precise control over a wide range of flow/pressure by bringing pumps online as needed. For systems with one or more connected DG1 devices.
- **Process variable representation in PID controller** – Makes things easier for operators by making it possible to directly show temperature and monitor them in the motor menu.
- **MPC - Multi follower** – Run a system of connected pumps with the same speed. This reduces stress on each pump and increases service intervals.
- **MPC - Multi master** - Provide precise control over a wide range of flow/pressure. Using multi master support a redundant setup is easy done. Trips the master, the slave drives takes over control without additional actions by the PLC.
- **110% overload** – Due to the lower overload requirement on chiller pumps the inverter can be dimensioned more cost effective.
- **Track changes** – The internal log helps during servicing to detect the root cause of a fault, minimizing down-time and diagnosis of accidental done changes.
- **Damper interlock** – Control a damper without external control hardware and ensure damper is in correct position before the drive begins running.
- **Multiple PID control loops** - Control your pump system with 2 built-in PID loops and eliminate the need for external control systems.

### Application protection

- **Automatic restart** – Brings chiller pumps back online after a power failure in order to minimize downtimes and potential system faults.
- **Derag function** – Utilize real time clock to run pump cleaning cycles of rapid acceleration and deceleration to prevent sediment buildup and clogging.
- **Reduce water-hammer** - Prevent unwanted water hammer and cavitation through smooth acceleration and deceleration ramps controlled by a pressure sensor.
- **Flying start** – Due to the lower overload requirement on chiller pumps the inverter can be dimensioned more cost effective.
- **Track changes** – Smoothly start spinning chiller pumps in either direction to reduce stress on the plunger.
- **Skip frequencies** - Reduce vibration and noise of the plunger by preventing operation in resonance causing speeds.

### Plant control & service

- **Cold weather mode** – Makes it possible to run machines even at extremely low temperatures inside the switch gear room without the need for external heating.
- **Improved fault troubleshooting** – Complete fault history utilizing real time clock to time stamp and record system parameters upon fault conditions for the last 8 faults. Improves fault diagnosis and reduces service and down time.

### Motor control

- **Stall protection** – Quicker response than overcurrent protection for instances of overweight and jammed conveyors or material handling systems to maintain a healthy system.
- **Motor-ID run** – Automatically determines the motor parameters required in order to maximize performance and efficiency as appropriate for the current pump configuration.

### Energy efficiency

- **Active energy saving function** – On-board algorithm to dynamically adjust the volts per hertz curve to find the lowest possible power output to maintain the required pump output. Classical static procedures are less good as load peaks will influence the speed accuracy.
- **Sleep mode** – Prevents the pump from continuing to rotate when the pressure falls below an adjustable value and no fluid is being pumped any more. By automatically stopping the pump, this mode lowers energy consumption, wear and costs.
- **Energy savings calculator** – The PC tool calculates the actual energy cost and savings compared to a conventional starter (DOL) already before buying the drive.
- **Energy savings function** – Provides 2-10% energy savings over competitors "out of box" mode without motor tuning.
- **Energysavings to DOL** – Eaton drives provide up to 50% energy savings over direct on line (DOL) starters.

### Management and communication

- **Extension slots** – Beside substantial On-Board I/O, various extension boards are available (2 slots) to directly connect all signals and sensors to DG1 for chiller pumps control, monitoring and status control.
- **Communication** – Best-in-class on-board communications includes Modbus RTU, Modbus TCP, Ethernet/IP, BACnet MS/TP with additional option boards for Profibus, CANopen, DeviceNet and SmareWire-DT to integrate into any desired network within a facility.

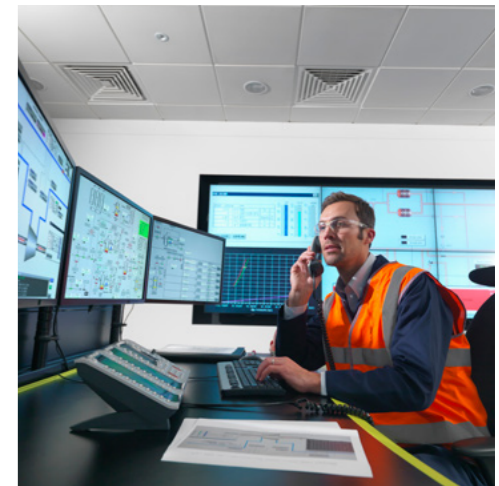

# Wiring diagram pressure control

Following a sample wiring diagram is shown for a simple pressure control. Labels of the inputs/outputs are shown for default, eventually the need to be adapted to the desired function.

Variant:

- ① Simple speed reference without control
- ② additional Feedback signal with PID control

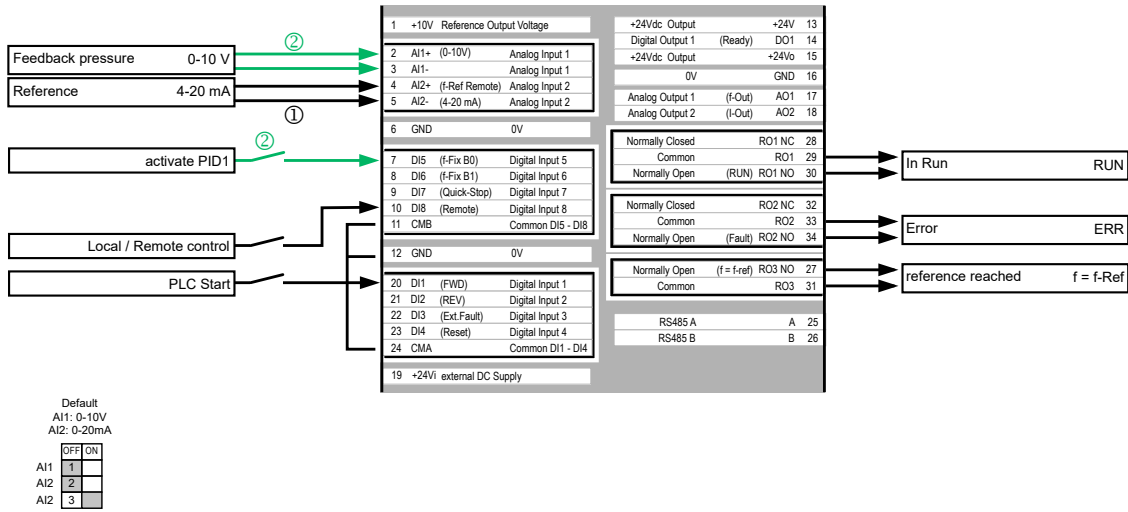

## Further documents

### Common hints

Electromagnetic compatibility (EMC)	<a href="#">AP040043EN</a>
Dual rating – What exactly does that mean?	<a href="#">AP040114EN</a>
Connecting drives to generator supplies	<a href="#">AP040169EN</a>

### DG1 specific hints

Application manual DG1	<a href="#">MN040004EN</a>
Communication manual DG1	<a href="#">MN040010EN</a>
Installation manual DG1 FR 0-6	<a href="#">MN040002EN</a>
Operating at low temperatures	<a href="#">AP040058EN</a>
DG1 in pump- and fan applications	<a href="#">AP040128EN</a>
Real time clock and use of the timers	<a href="#">AP040172EN</a>
Analog I/Os	<a href="#">AP040129EN</a>
Digital I/Os	<a href="#">AP040132EN</a>
Load balancing in multi motor applications	<a href="#">AP040168EN</a>
Motordata and V/f curves	<a href="#">AP040177EN</a>
PID controller	<a href="#">AP040164EN</a>
Smoke mode and fire mode	<a href="#">AP040065EN</a>
Starting, stopping and operation	<a href="#">AP040176EN</a>

Following link will show you the Application notes for DG1: [Eaton.com/ap/overview/drives](https://www.eaton.com/ap/overview/drives)  
 DG1-Manuals you can find at: [Eaton.com/dg1](https://www.eaton.com/dg1)

### Services

For service and support, please contact your local sales organisation.  
 Contact details: [Eaton.com/contacts](https://www.eaton.com/contacts)  
 Service page: [Eaton.com/aftersales](https://www.eaton.com/aftersales)