

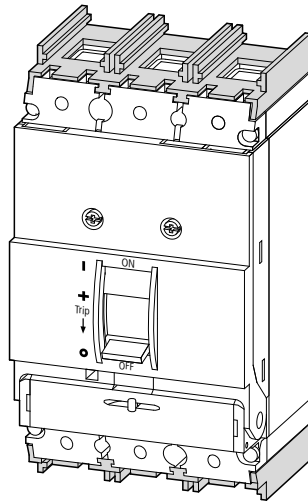

Powering Business Worldwide

11/15 IL01203004Z
(AWA1230-1913, AWA1230-2537)

NZMB(C)(N)(S)(H)1(-4)-A(M)(S)... -NA
NZMB(N)1-A(AF)... -CNA
NZMB(N)1-S... -CNA
(P)N1-...(-NA)
NS1-...-NA
 (UL/ CSA Models)

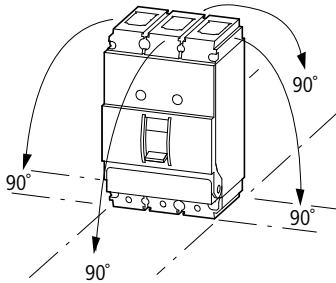

⚠️ en Electric current! Danger to life!
 Only skilled or instructed persons may carry out the following operations.

de Lebensgefahr durch elektrischen Strom!
 Nur Elektrofachkräfte und elektrotechnisch unterwiesene Personen dürfen die im Folgenden beschriebenen Arbeiten ausführen.

fr Tension électrique dangereuse !
 Seules les personnes qualifiées et averties doivent exécuter les travaux ci-après.

es ¡Corriente eléctrica! ¡Peligro de muerte!
 El trabajo a continuación descrito debe ser realizado por personas cualificadas y advertidas.

it Tensione elettrica: Pericolo di morte!
 Solo persone abilitate e qualificate possono eseguire le operazioni di seguito riportate.

zh 触电危险!
 只允许专业人员和受过专业训练的人员进行下列工作。

ru Электрический ток! Опасно для жизни!
 Только специалисты или проинструктированные лица могут выполнять следующие операции.

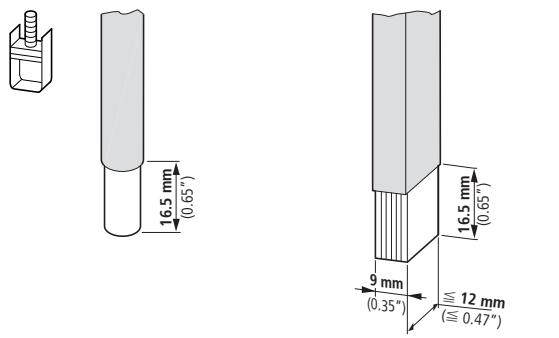

1 x 10 - 70 mm ² (95 mm ²)*	≥ 2 x 9 x 0.8 mm ≥ 2 x 0.35" x 0.03"
2 x 6 - 25 mm ²	
1 x AWG 12 - 1 x AWG 2/0	

UL/CSA = Cu only, Ampacity per 75° C Table.

* Max. 95 mm² can be connected depending on the cable manufacturer

Je nach Kabelhersteller bis zu 95 mm² anschließbar

Selon le fabricant de câble, possibilité de raccorde jusqu'à 95 mm²

Dependiendo del fabricante del cable pueden conectars hasta 95 mm²

Sezione max collegabile 95 mm² in base al produttor del cavo

根据不同的电缆制造商,可连接最大 95 mm²

В зависимости от производителя кабеля можн подключатьдо 95 мм²

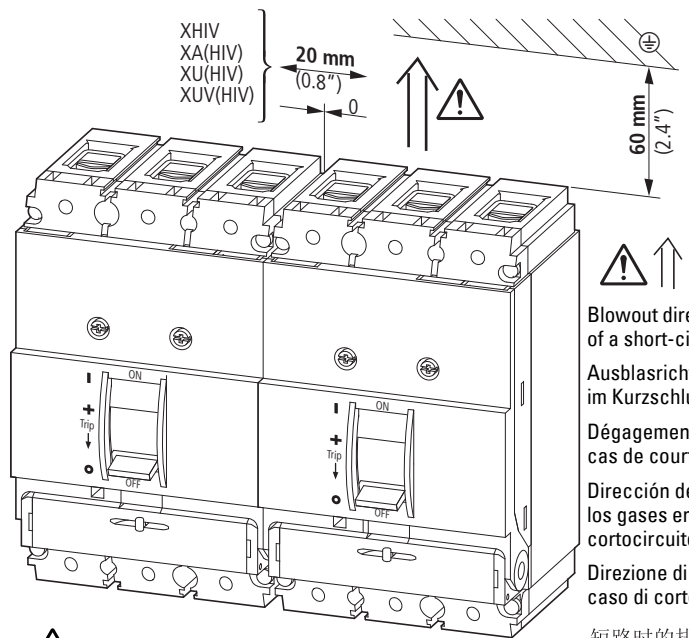

⚠️ Blowout direction in case of a short-circuit
 Ausblasrichtung im Kurzschlussfall
 Dégagement gazeux en cas de court-circuit
 Dirección de salida de los gases en caso de cortocircuito
 Direzione di estinzione in caso di corto circuito
 短路时的排空方向
 Направление продувки в случае короткого замыкания

⚠️ Minimum Clearance space for all models

⚠️ en Caution!
 The removal or exchange of parts during mounting may become necessary. Refer to installation instructions for proper assembly and to maintain electrical clearances.

de Vorsicht!
 Für die Durchführung der beschriebenen Arbeiten kann das Entfernen oder der Austausch von Teilen notwendig sein. Bitte alle Installations-Anweisungen beachten, um die erforderlichen Luft- und Kriechstrecken nach dem Zusammenbau zu gewährleisten.

fr Attention !
 L'enlèvement ou l'échange de certaines pièces pendant le montage est parfois nécessaire. Consultez l'instruction d'assemblage pour assurer une installation conforme aux normes.

es ¡Atención!
 Con el fin de llevar a cabo los trabajos descritos, puede ser necesario eliminar o cambiar alguna pieza. Le rogamos tenga en cuenta todas las instrucciones de instalación para así garantizar las líneas de fuga y efluvio necesarias tras el montaje.

it Attenzione!
 Per l'esecuzione degli interventi descritti potrebbe essere necessaria la rimozione o sostituzione di alcuni pezzi. Attenersi alle istruzioni d'installazione per garantire dopo l'assemblaggio le vie di dispersione necessarie.

zh 小心!
 执行所描述的操作时可能需要拆除或更换零部件。请遵守所有相关的安装说明,以确保在组装后能获得需要的空间距离或爬电距离。

ru Осторожно!
 При проведении описанных процедур может возникнуть необходимость демонтировать или заменить детали. Для обеспечения надлежащих зазоров и вывода тока утечки, соблюдайте все инструкции по монтажу.

NZM.1(-4)-...

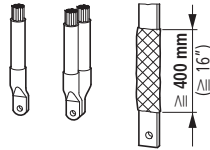
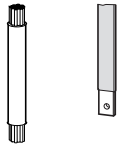
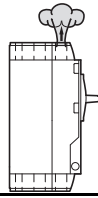

≤ 415 V

①

XKP oder* XKSA

① +

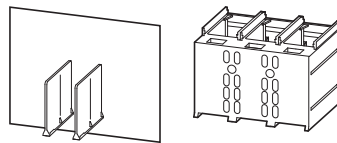

≤ 690 V

①

XKSA

① +

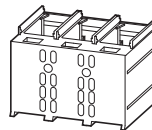

- ① Basic device – Grundgerät – Appareil de base – Aparato base – Apparecchio base – 基础设备 – Основное устройство
- + Combination options – Kombinationsmöglichkeiten – Combinaisons possibles – Combinaciones posibles – Combinazioni possibili – 组合方法 – Комбинационные возможности
- * or – oder – ou – ó – oppure – 或者 – или

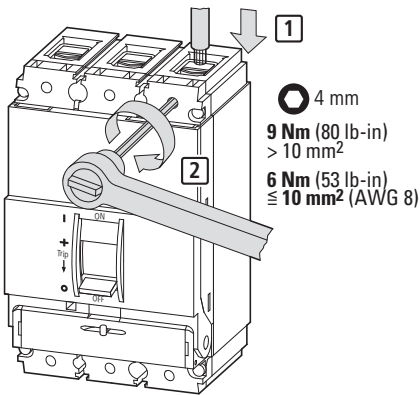

1

Settings
Einstellung
Réglages
Parámetros
Regolazione
设置
Настройка

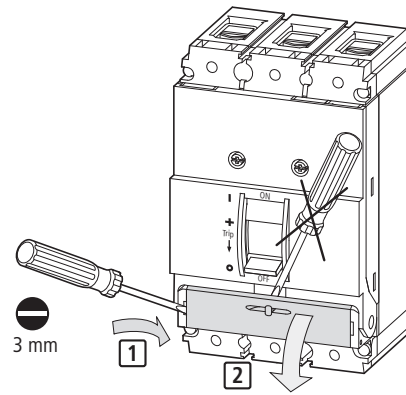

2

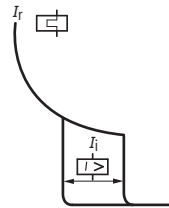
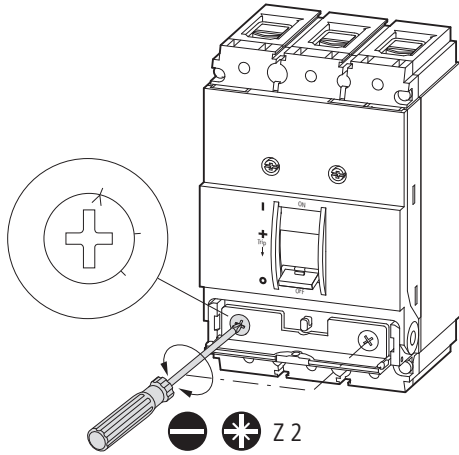

Note: On certain models with UL/CSA labeling the thermal trip setting is fixed and only the magnetic trip (instantaneous) setting is adjustable.

Setting I_i with DC = setting I_i AC/1.25
 Einstellwert I_i bei DC = Einstellwert I_i AC/1,25
 Valeur de réglage I_i avec DC = valeur de réglage I_i AC/1,25
 Valor de respuesta I_i con DC = valore de respuesta I_i AC/1,25
 Valore di regolazione I_i con DC = valore di regolazione I_i AC/1,25
 DC 的设置值 I_i = AC/1.25 的设置值 I_i
 Значение I_i при постоянном токе = I_i при переменном токе /1.25

M22-K10
M22-K01
M22-CK10
M22-CK01
Auxiliary Switches

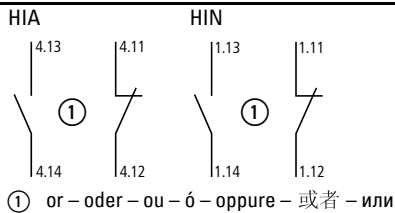

Notes on mounting and wiring Auxiliary Switches for UL/CSA labeled models:

- M22-K(10)(01) have screw terminals. M22-CK(10)(01) have clamp terminals.
- Switch modules are snapped into place at the locations shown in the diagrams that follow.
- Switches will function as either „standard“ or „trip/alarm“ contacts depending on their mounting location.
- Location „HIN“ refers to standard operation. Location „HIA“ refers to „trip/alarm“ operation.
- Follow the numbering and wiring scheme provided above depending on the contact location and function. (N.O. or N.C.)
- Permissible contact configuration: 1 HIA and/or 1 HIN.

-NA
-CNA
(UL/CSA)



I_{th} = I_e

U _e (V)	I _e (A)
600 AC	5 A
250 DC	1 A

Pilot Duty Ratings:
 B 600, Q 300
 Above 300 VAC
 Same polarity

IEC



I_{th} = I_e

	U _e (V)	I _e (A)
AC-15	115	4
	230	4
	400	2
DC-13	500	1
	24	3
	42	1.7
	60	1.2
	110	0.6
	220	0.3



Note: After mounting of the M22... switch is complete, check off the appropriate box on the auxiliary switch label provided on the side of the breaker or switch.

M22-CK11
M22-CK20
M22-CK02

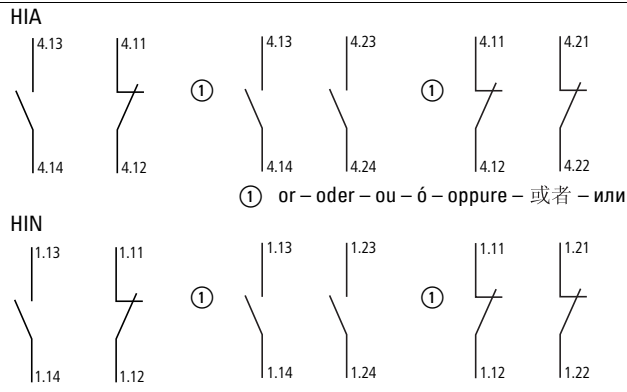

IEC



$I_{th} = I_e$

	U_e (V)	I_e (A)
AC-15	115	4
	230	4
DC-13	24	3
	42	1
	60	0.8
	110	0.5
	220	0.2

Mounting – Montage – Montage – Montaggio – Montaje – 安裝 – Монтаж

1

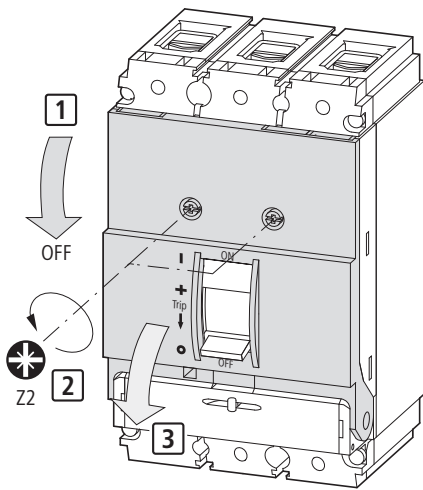

2

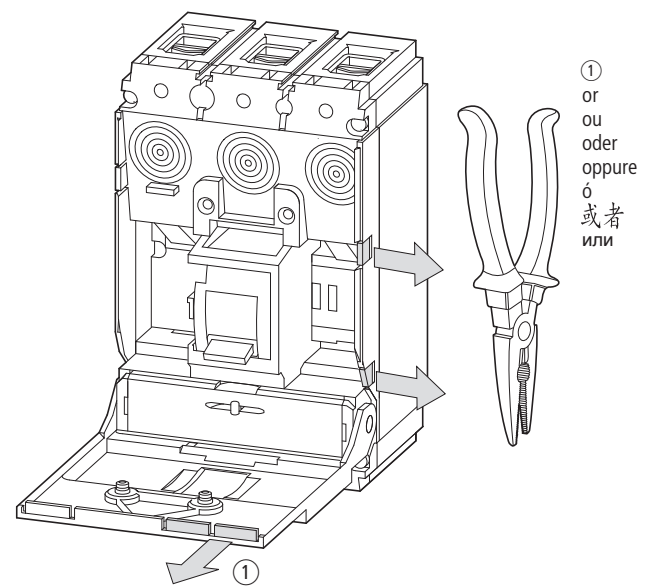

11/15 IL01203004Z

3

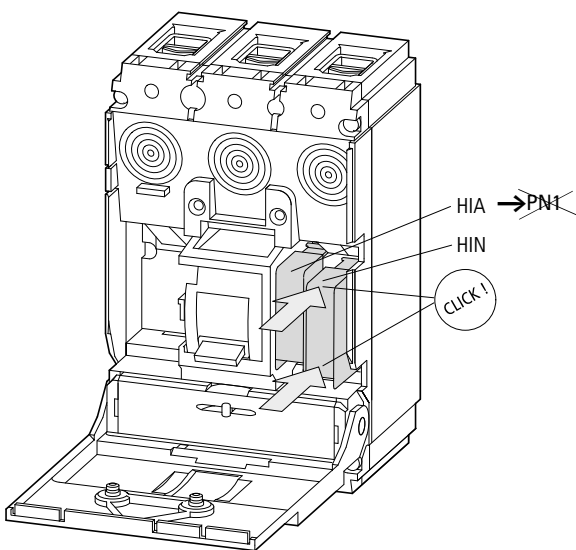

4

M22-K10
M22-K01

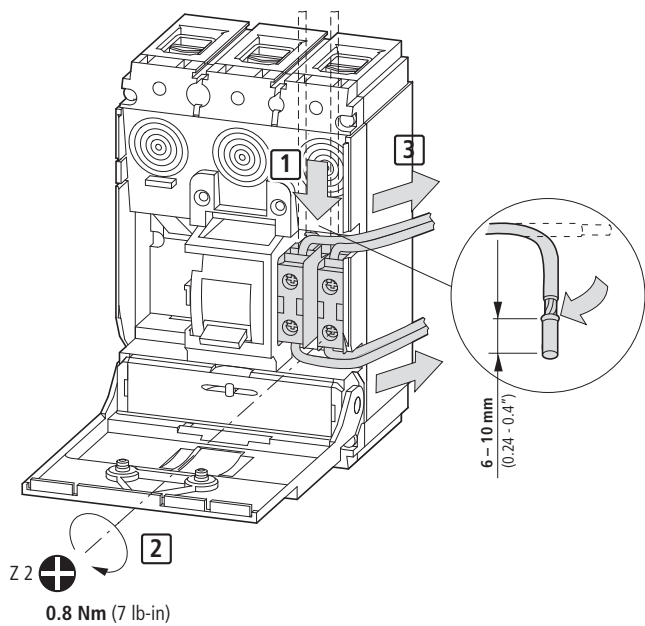

	2 x 0.75 - 2.5 mm ²
	2 x AWG18 - AWG14
	UL/CSA = Cu only

4b

**M22-CK10
M22-CK01**

	2 x 0.75 - 2.5 mm ²
	2 x AWG18 - AWG14
UL/CSA = Cu only	

4c

**M22-CK11 M22-CK02
M22-CK20**

	a = 8 mm
	a = 0.3"
	1 x 0.5 - 1.5 mm ²
	2 x 0.5 - 0.75 mm ²

5

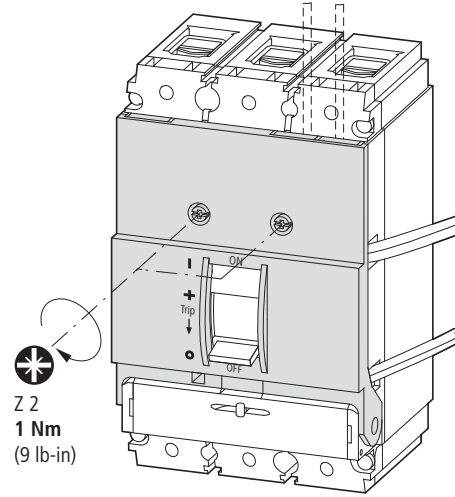
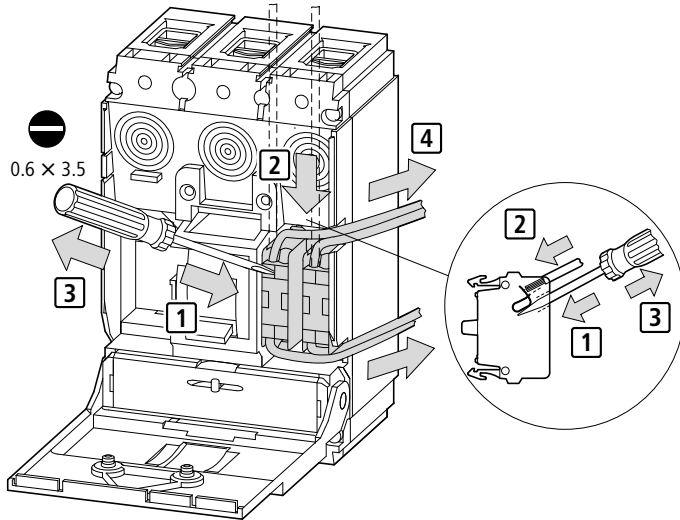

TEST 1

11/15 IL01203004Z

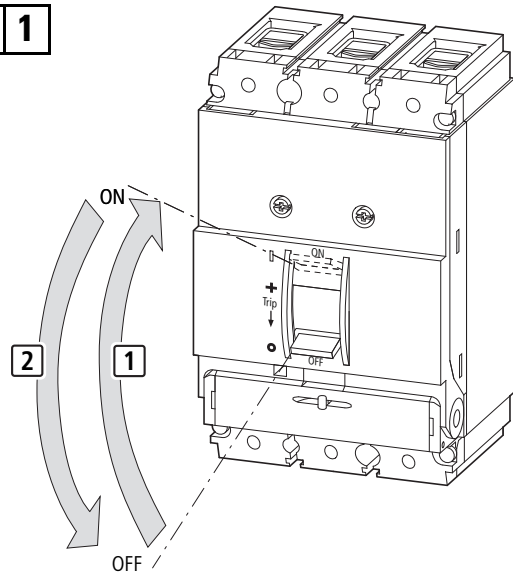

TEST 2

~~PN1 ...~~

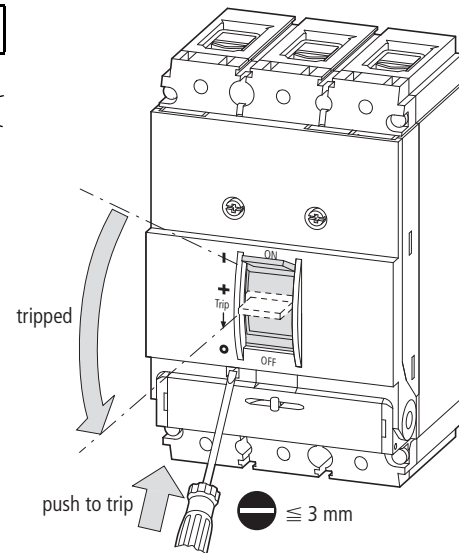

TEST 3

~~PN1 ...~~

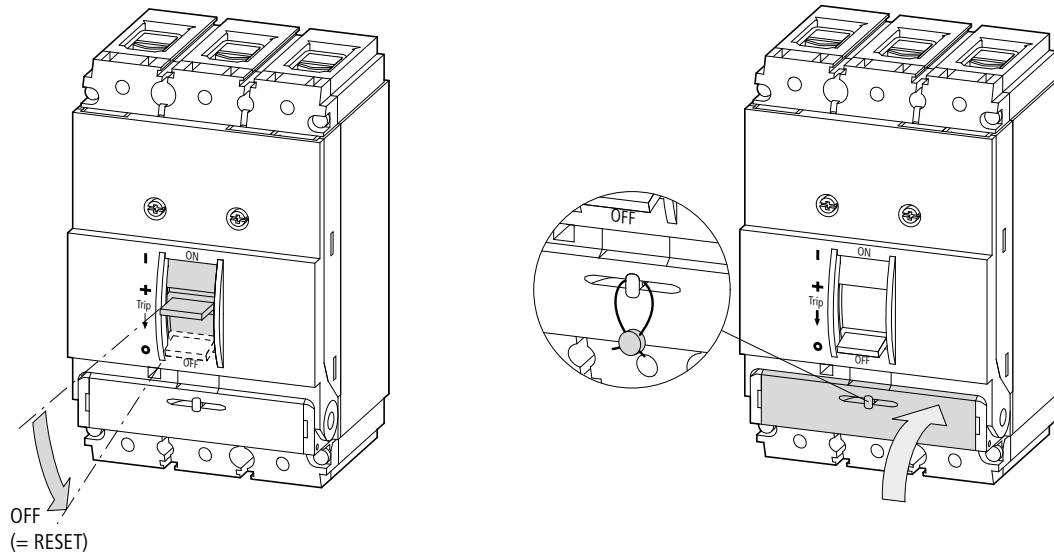

Einklappseite: 17 mm Beschnitt

Dismounting – Demontage – Démontage – Desmontaje – Smontaggio – 拆卸 – Демонтаж

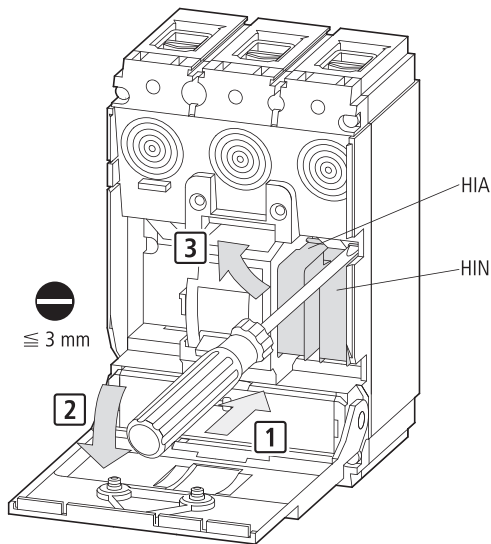

**Wiring terminations circuit breaker type NZM...1...-NA (CNA)
Wiring terminations molded case switch type N(S)1...-NA**

Connector Type	Wire size	Wire 75° C	Max. A-Rating	Tightening-Torque
1) NZM1-XKC	1 x AWG 2/0 - 12	Cu only	125	9 Nm (80 lb-in) 6 Nm (53 lb-in) (AWG 8 - 12)
NZM1-XKA	1 x AWG 3/0 - 6	Cu only	125	15 Nm (133 lb-in)
NZM1-XKS	1 x AWG 2/0 - 8	Cu only	125	9 Nm (80 lb-in)
2) Integrated Auxiliary Terminal	1 x AWG 12 - 18	Cu only		1.2 Nm (11 lb-in)

- 1) Connector Type NZM1-XKC supplied standard on all NZM1 circuit breakers and switches.
- 2) Integrated Auxiliary Terminal on Connector Type NZM1-XKA only.

Einklappseite: 17 mm Beschnitt

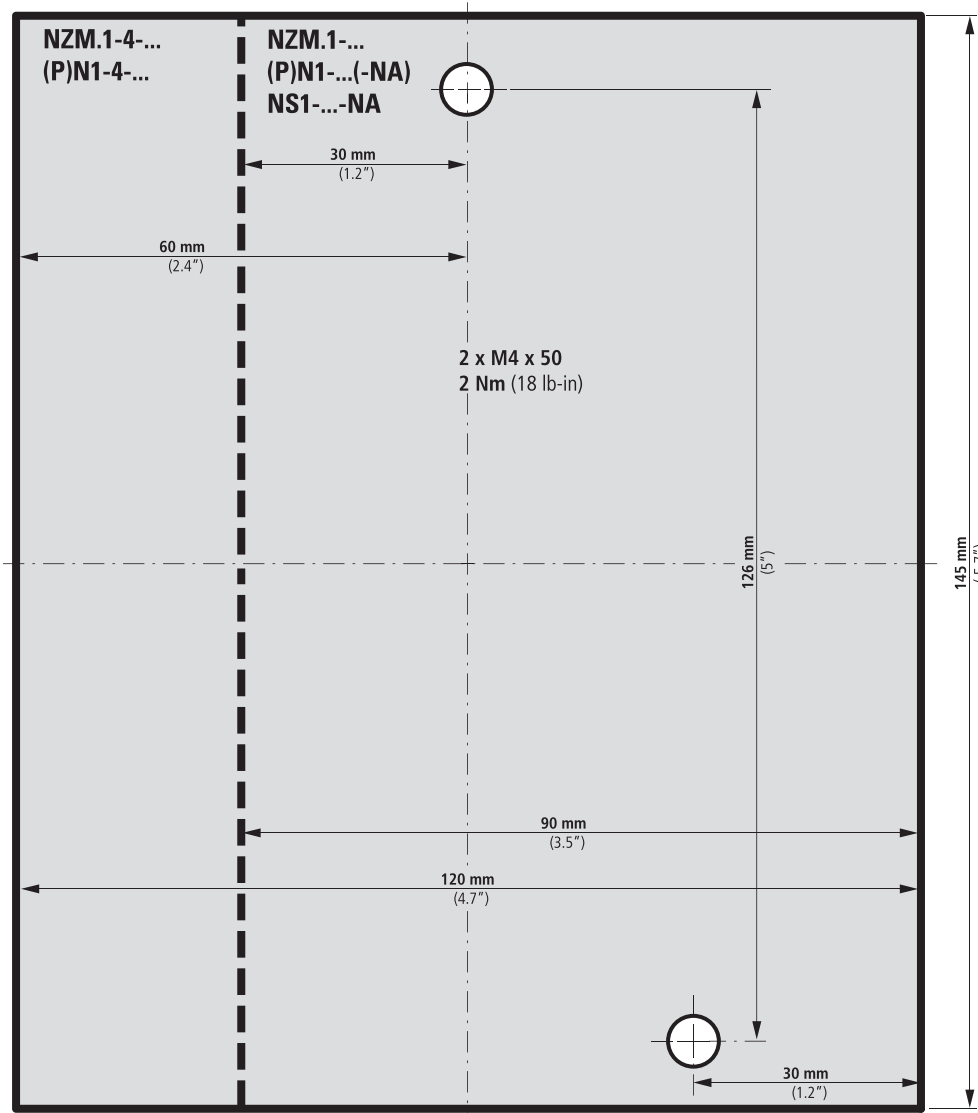

11/15 IL01203004Z

