

# Instructions for Neutral Current Sensor - IZMX40/IZM97/IZM99 with PXR

Instructions apply to:

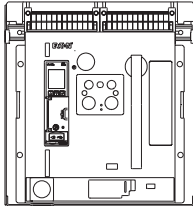

---

## **⚠ WARNING**

- (1) ONLY QUALIFIED ELECTRICAL PERSONNEL SHOULD BE PERMITTED TO WORK ON THE EQUIPMENT.
- (2) ALWAYS DE-ENERGIZE PRIMARY AND SECONDARY CIRCUITS IF A CIRCUIT BREAKER CANNOT BE REMOVED TO A SAFE WORK LOCATION.
- (3) DRAWOUT CIRCUIT BREAKERS SHOULD BE LEVERED (RACKED) OUT TO THE DISCONNECT POSITION.
- (4) ALL CIRCUIT BREAKERS SHOULD BE SWITCHED TO THE OFF POSITION AND MECHANISM SPRINGS DISCHARGED.

FAILURE TO FOLLOW THESE STEPS FOR ALL PROCEDURES DESCRIBED IN THIS INSTRUCTION LEAFLET COULD RESULT IN DEATH, BODILY INJURY, OR PROPERTY DAMAGE.

---

## **⚠ WARNING**

THE INSTRUCTIONS CONTAINED IN THIS IL AND ON PRODUCT LABELS HAVE TO BE FOLLOWED. OBSERVE THE FIVE SAFETY RULES:

- DISCONNECTING;
- ENSURE THAT DEVICES CANNOT BE ACCIDENTALLY RESTARTED;
- VERIFY ISOLATION FROM THE SUPPLY;
- EARTHING AND SHORT-CIRCUITING; AND
- COVERING OR PROVIDING BARRIERS TO ADJACENT LIVE PARTS.

DISCONNECT THE EQUIPMENT FROM THE SUPPLY. USE ONLY AUTHORIZED SPARE PARTS IN THE REPAIR OF THE EQUIPMENT. THE SPECIFIED MAINTENANCE INTERVALS AS WELL AS THE INSTRUCTIONS FOR REPAIR AND EXCHANGE MUST BE STRICTLY ADHERED TO PREVENT INJURY TO PERSONNEL AND DAMAGE TO THE SWITCHBOARD.

# **EATON**

*Powering Business Worldwide*

### Section 1: Neutral Current Sensor Installation

Ground Fault Trip Units detect ground fault currents through Residual Sensing. A different, round, toroidal sensor is required for source ground or zero sequence sensing. All further information is for residual ground fault sensing method only. If the system neutral is grounded and residual ground fault is desired, but no phase to neutral loads are used, a neutral current sensor is not necessary. In that case, a jumper wire is required between circuit breaker secondary contact positions 11 and 12 (factory installed).

If the system neutral is grounded and phase to neutral loads are used, then the neutral current sensor (see Figure 3) must be used to account for this load in the residual ground fault sensing. It has the same turns ratio as the phase current sensors in the Series Magnum circuit breaker. The neutral sensor is an air core design and can be used with all Type RF In ratings (Figure 1). **The factory installed jumper wire at secondary contact positions 11 and 12 must be removed before installing the neutral current sensor.** See Figure 2 for installation details.

### Section 2: Performance Testing For Ground Fault Circuit Breakers

#### General Test Instructions

The interconnect system shall be evaluated in accordance with the equipment assembler's detailed instruction by qualified personnel.

The polarity of the neutral sensor connection (if used) must agree with equipment assembler's detailed instructions to avoid improper operations following apparently correct simulated test operations. Where a question exists, consult the specifying engineer and/or equipment assembler.

The grounding points of the system shall be verified to determine that ground paths do not exist that would bypass the sensors. Highvoltage testers and resistance bridges may be used.

### ⚠ IMPORTANT

**THE POLARITY OF THE SENSOR CONNECTIONS IS CRITICAL. ALWAYS OBSERVE THE POLARITY MARKINGS ON THE INSTALLATION DRAWINGS. THE POLARITY MARKINGS ARE IDENTIFIED AS WHITE DOTS ON THE TRANSFORMERS. TO INSURE CORRECT GROUND FAULT EQUIPMENT PERFORMANCE, CONDUCT FIELD TESTS TO COMPLY WITH NATIONAL ELECTRIC CODE REQUIREMENTS UNDER ARTICLE 230-95-C. SEE PERFORMANCE TESTING INSTRUCTIONS ON FOLLOWING PAGES.**

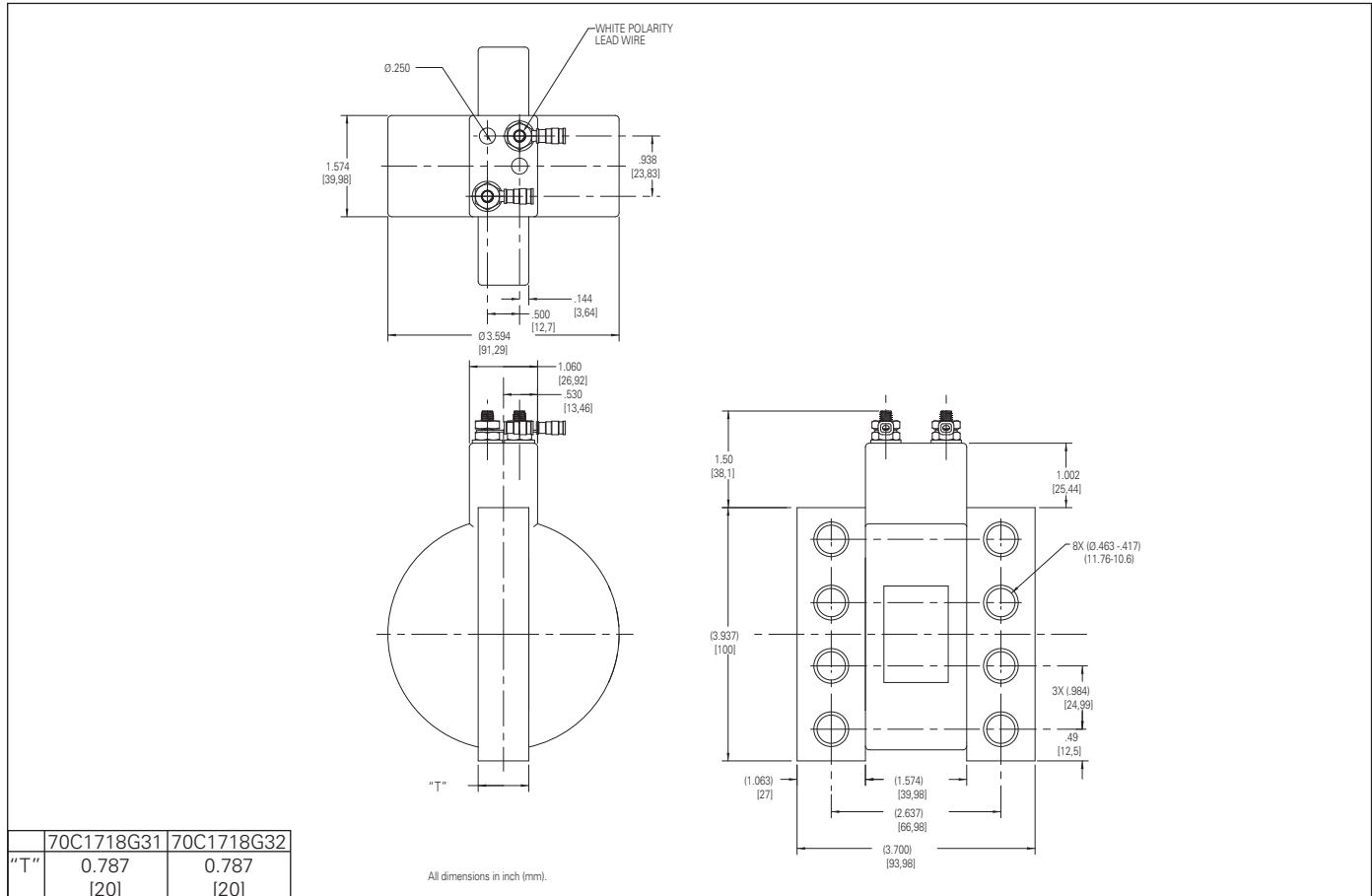
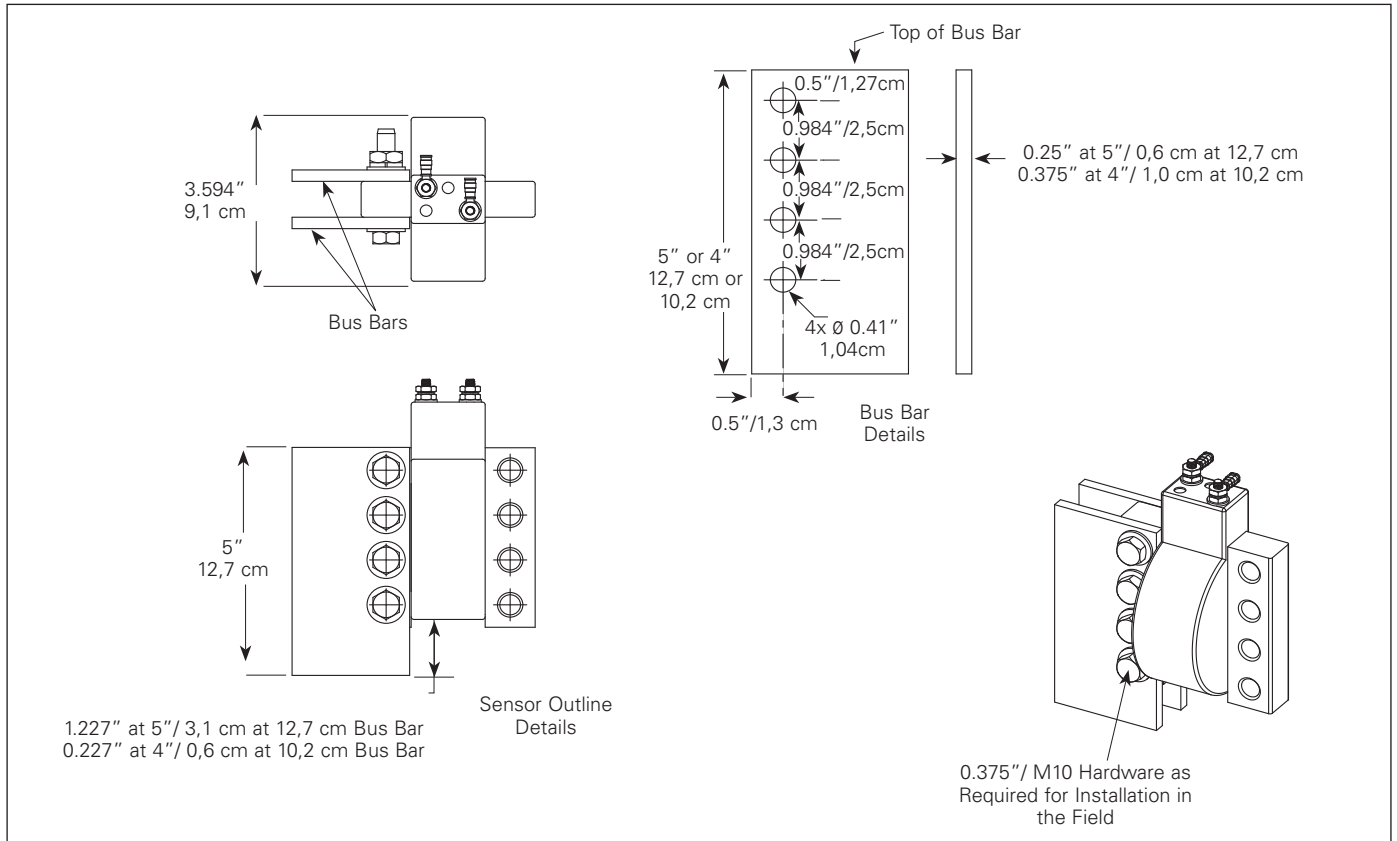
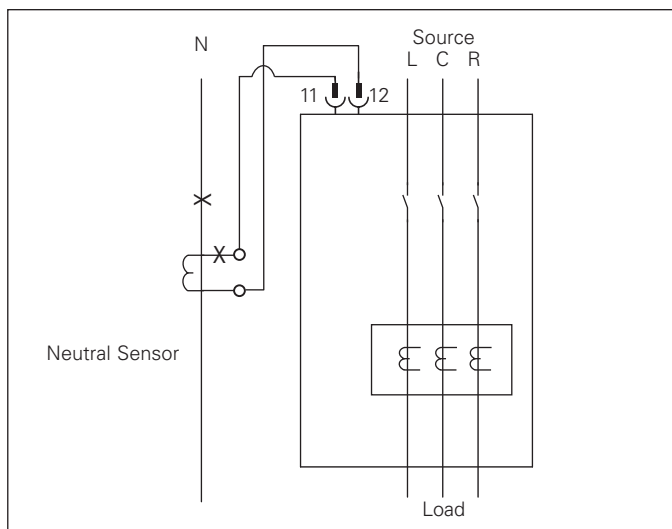

Figure 1. Dimensions.



**Figure 2. Sensor Installation Information.**



**Figure 3. Neutral Current Sensor Application (IEC).**

**Note:** Since the ground fault circuit breakers derive their operating power from the phase current and not from the neutral current, passing current through the neutral sensor only will not properly test the ground fault feature.

Using a low voltage (0 - 24 V) high current AC source, apply a test current of 125% of the ground fault pick-up setting through one phase of the circuit breaker as displayed in Figure 4. This should cause the breaker to trip in less than one second, and if an alarm indicator is supplied, it should operate. Reset the breaker and the alarm indicator. Repeat the test on the other two phases.

If the system is a 4-wire system with a neutral current sensor, apply the same current as described above through one phase of the breaker, returning through the neutral sensor, as displayed in Figure 5. The breaker should not trip and the alarm indicator, if supplied, should not operate. Repeat the test on the other two phases.

If the system is a 3-wire system with no neutral current sensor, apply the same current as described above through any two phases of the breaker with the connections as displayed in Figure 6. The breaker should not trip and the alarm indicator, if supplied, should not operate.

Repeat the test using the other two combinations of breaker phases.

Record the test results on the test form provided with the equipment.

**CAUTION**

**FIELD TESTING SHOULD BE USED FOR FUNCTIONAL TESTING, NOT FOR FIELD CALIBRATION. IF TEMPORARY CONNECTIONS WERE MADE FOR THE PURPOSE OF CONDUCTING TESTS, RESTORE TO PROPER OPERATING CONDITIONS BEFORE RETURNING THE BREAKER TO SERVICE.**

**WARNING**

**ELECTRICAL SHOCK OR BURN INJURY CAN OCCUR WHEN WORKING ON POWER SYSTEMS. ALWAYS TURN OFF POWER SUPPLYING CIRCUIT BREAKER BEFORE CONDUCTING TESTS. TEST OUT OF THE CELL, IF POSSIBLE.**

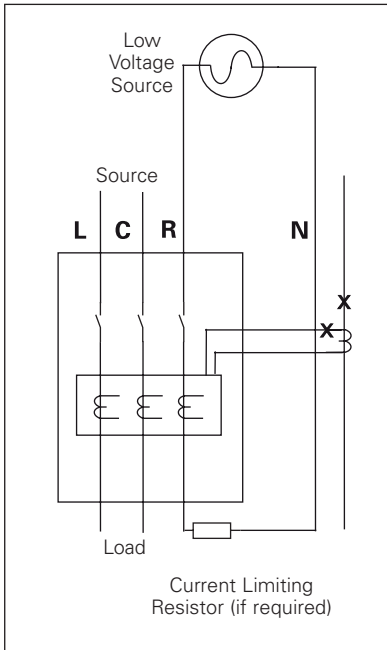

**Figure 4. Connections for Ground Fault Trip Test.**

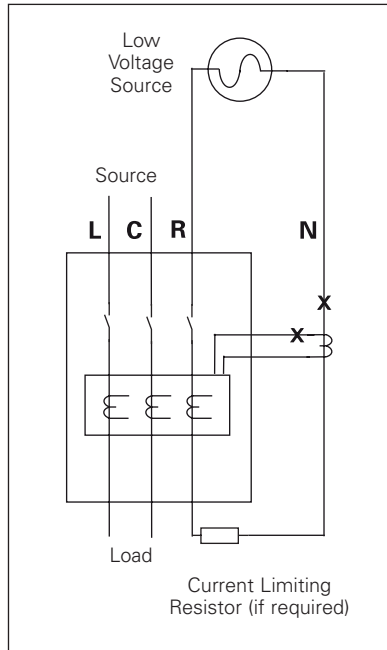

**Figure 5. Connections for Ground Fault No-Trip Test with a 4-Wire system.**

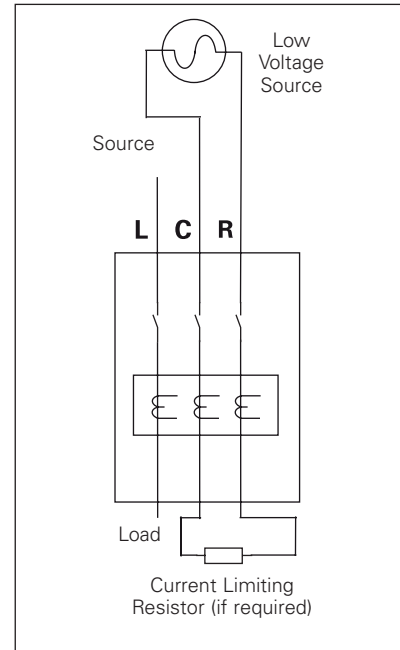

**Figure 6. Connections for Ground Fault No-Trip Test with a 3-Wire System.**

**Notes:**

## Disclaimer of warranties and limitation of liability

The information, recommendations, descriptions, and safety notations in this document are based on Eaton Corporation's ("Eaton") experience and judgment, and may not cover all contingencies. If further information is required, an Eaton sales office should be consulted.

Sale of the product shown in this literature is subject to the terms and conditions outlined in appropriate Eaton selling policies or other contractual agreement between Eaton and the purchaser.

THERE ARE NO UNDERSTANDINGS, AGREEMENTS, WARRANTIES, EXPRESSED OR IMPLIED, INCLUDING WARRANTIES OF FITNESS FOR A PARTICULAR PURPOSE OR MERCHANTABILITY, OTHER THAN THOSE SPECIFICALLY SET OUT IN ANY EXISTING CONTRACT BETWEEN THE PARTIES. ANY SUCH CONTRACT STATES THE ENTIRE OBLIGATION OF EATON. THE CONTENTS OF THIS DOCUMENT SHALL NOT BECOME PART OF OR MODIFY ANY CONTRACT BETWEEN THE PARTIES.

In no event will Eaton be responsible to the purchaser or user in contract, in tort (including negligence), strict liability, or otherwise for any special, indirect, incidental, or consequential damage or loss whatsoever, including but not limited to damage or loss of use of equipment, plant or power system, cost of capital, loss of power, additional expenses in the use of existing power facilities, or claims against the purchaser or user by its customers resulting from the use of the information, recommendations, and descriptions contained herein.

The information contained in this manual is subject to change without notice.

**Eaton**  
Electrical Sector  
1000 Eaton Boulevard  
Cleveland OH 44122  
United States  
877-ETN-CARE (877-386-2273)  
Eaton.com

© 2020 Eaton  
All Rights Reserved  
Printed in USA  
Publication No. IL0131094EN/TBG001203  
Part Number: IL0131094ENH03  
June 2020

Eaton is a registered Trademark.

All other trademarks are property of their respective owners.