

Installation and Removal Instructions for Series NRX Kirk Key Interlock Kit

Instructions apply to:

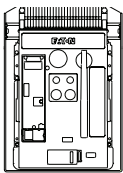

Series NRX, Type NF Frame
ANSI, UL1066, UL489 / IEC, IZMX16, IZM91

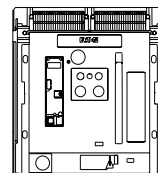

Series NRX, Type RF Frame
IEC, IZMX40

⚠ WARNING

- (1) ONLY QUALIFIED ELECTRICAL PERSONNEL SHOULD BE PERMITTED TO WORK ON THE EQUIPMENT.
 - (2) ALWAYS DE-ENERGIZE PRIMARY AND SECONDARY CIRCUITS IF A CIRCUIT BREAKER CANNOT BE REMOVED TO A SAFE WORK LOCATION.
 - (3) DRAWOUT CIRCUIT BREAKERS SHOULD BE LEVERED (RACKED) OUT TO THE DISCONNECT POSITION.
 - (4) ALL CIRCUIT BREAKERS SHOULD BE SWITCHED TO THE OFF POSITION AND MECHANISM SPRINGS DISCHARGED.
- FAILURE TO FOLLOW THESE STEPS FOR ALL PROCEDURES DESCRIBED IN THIS INSTRUCTION LEAFLET COULD RESULT IN DEATH, BODILY INJURY, OR PROPERTY DAMAGE.
-

⚠ WARNING

THE INSTRUCTIONS CONTAINED IN THIS IL AND ON PRODUCT LABELS HAVE TO BE FOLLOWED. OBSERVE THE FIVE SAFETY RULES:

- DISCONNECTING
- ENSURE THAT DEVICES CANNOT BE ACCIDENTALLY RESTARTED
- VERIFY ISOLATION FROM THE SUPPLY
- EARTHING AND SHORT-CIRCUITING
- COVERING OR PROVIDING BARRIERS TO ADJACENT LIVE PARTS

DISCONNECT THE EQUIPMENT FROM THE SUPPLY. USE ONLY AUTHORIZED SPARE PARTS IN THE REPAIR OF THE EQUIPMENT. THE SPECIFIED MAINTENANCE INTERVALS AS WELL AS THE INSTRUCTIONS FOR REPAIR AND EXCHANGE MUST BE STRICTLY ADHERED TO PREVENT INJURY TO PERSONNEL AND DAMAGE TO THE SWITCHBOARD.

EAT•N

Powering Business Worldwide

Section 1: General information

The key interlock secures the breaker in the "OFF" position. It is mounted in the upper portion of the breaker and can be viewed from the front cover. The customer supplies the keylock. The following safety features are provided:

1. With NO Key, the breaker is "OPEN" and cannot close.
2. With the Key ON (key in the cylinder) and rotated, the breaker is fully functional.
3. The key cannot be removed when the breaker is ON (closed).

Note: To remove the key, press the breaker OFF button, and rotate the key 90 degrees counterclockwise.

Kit Parts Identification

Refer to **Figure 1** for visual identification of the parts listed below:

- (A) External Protective Ring (self-adhesive) (1)
- (B) Kirk Keylock #KC40.10 (Kirk Keylock not supplied)
- (C) Support Washer (1))
- (D) Metal Mounting Bracket (1)
- (E) Fiber Retaining Washer (2)
- (F) M3 x 5mm Mounting Screw (2)
- (G) Large Locking Nut (1) (not part of kit, supplied with keylock)
- (H) Keylock Lever (1)
- (I) Machine Screw #3 (2)

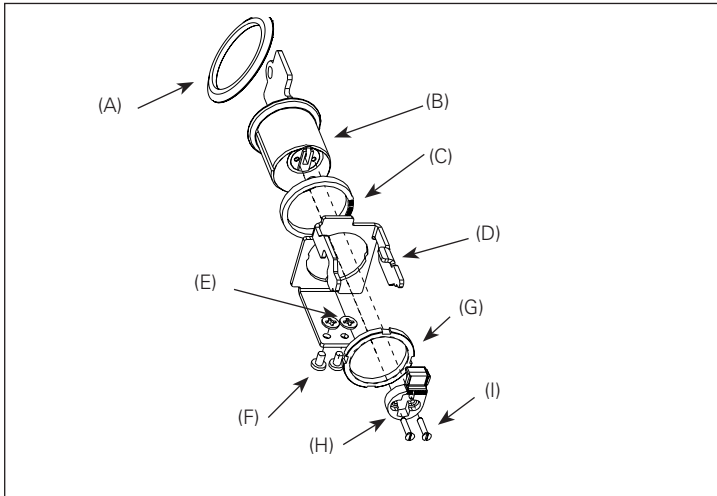

Figure 1. Contents of Kit

Section 2: Installation of Key Interlock

Proceed with the following 8 steps:

Step 1: Remove the four screws (six for 4-pole breaker) holding the front cover in place (two on each side of the cover).

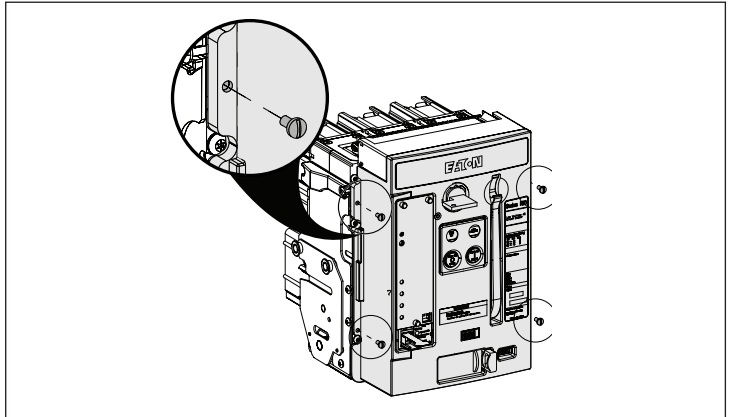

Figure 2. Step 1. NF Frame

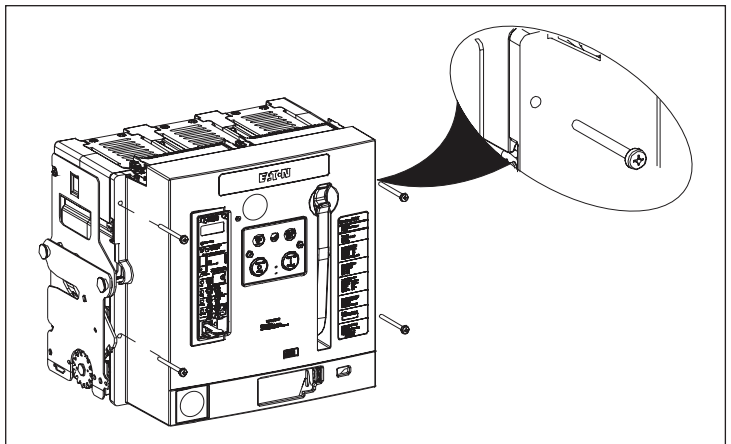

Figure 2a. Step 1. RF Frame

Step 2: Remove the front cover. Pull down on the charging handle to simplify removal.

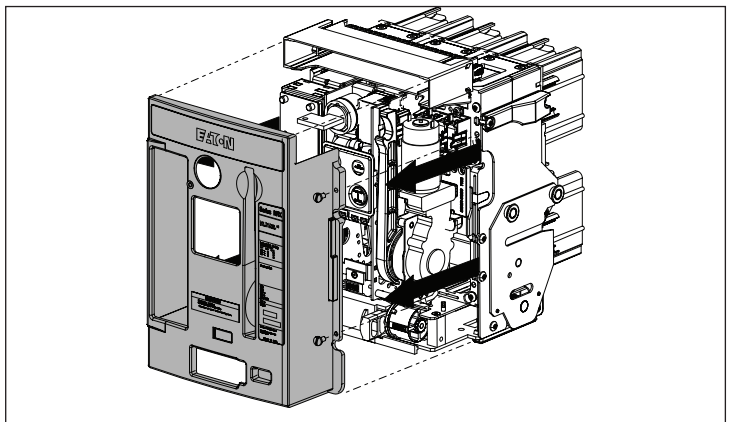

Figure 3. Step 2. NF Frame

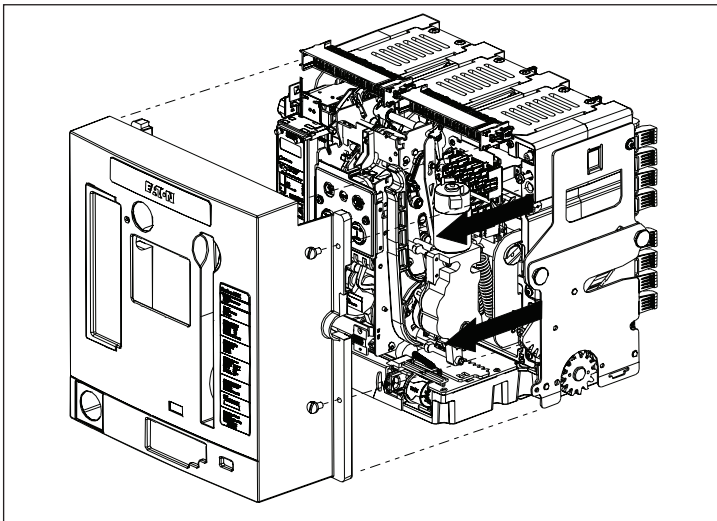

Figure 3a. Step 2. RF Frame

Step 3 (NF Frame Only): If this is a fixed circuit breaker, skip this step and proceed directly to Step 4. If this is a drawout circuit breaker, unscrew the three captive screws holding the secondary mounting bracket in place. This will permit the secondary mounting bracket to be moved down, providing access to the key interlock assembly's threaded mounting holes. No wires or connectors need to be removed or unplugged.

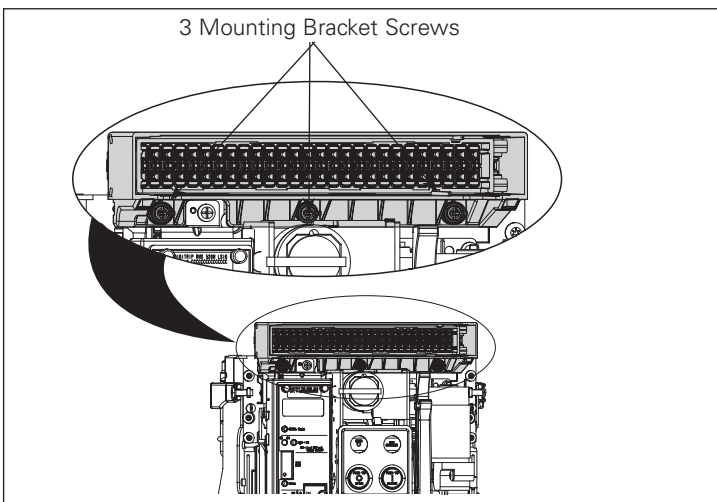

Figure 4. Step 3.

⚠ WARNING

THE KEY MUST BE REMOVED FROM LOCK (B) BEFORE PROCEEDING WITH STEP 4. THIS ENSURES THAT THE CYLINDER WILL NOT SLIDE OUT WITH KEY AND INTERNAL LOCKING PARTS. FAILURE TO FOLLOW THIS INSTRUCTION CAN RESULT IN IRREVERSIBLE EQUIPMENT DAMAGE.

Step 4: Refer to **Figure 1** for orientation purposes. Remove the key from lock (B). Remove the lever arm that came installed on the back end of the lock by removing the two small screws holding it in place. Discard the removed lever arm, two screws and one of the large locking nuts supplied with the lock.

Step 5: Refer to **Figure 1** for assembly orientation. Push the support washer (C) onto the back end of the key lock (B). Mount the key lock (B) to the mounting bracket (D) with the large locking nut (G). Ensure that the large locking nut is firmly tightened. Mount the key lock lever (H) supplied with the kit to the back end of the lock using two machine screws (I) also supplied with the kit.

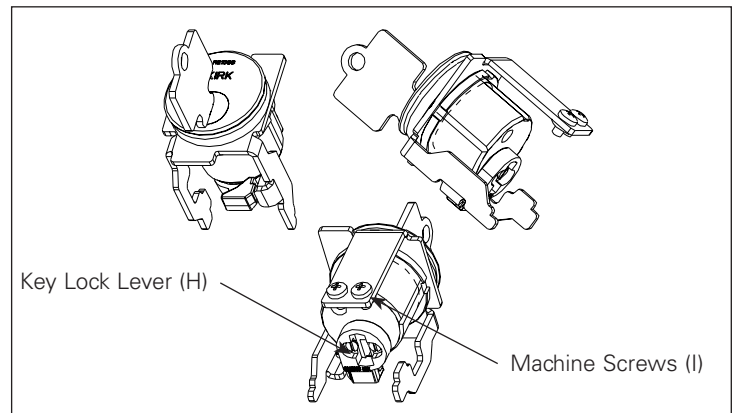

Figure 5. Steps 4 and 5

Step 6: Identify the mounting location for the key lock assembly. Two threaded mounting holes are provided in the mounting tab to accommodate the two Mounting Screws (F) and two Fiber Retaining Washers (E), which serve as spring washers when tightened. Position the key lock assembly and tighten the two mounting screws. Make sure the mounting bracket's sheet metal tab is positioned behind the plastic of the pushbutton plate. Use a small flat screwdriver to get the metal tab under the plastic.

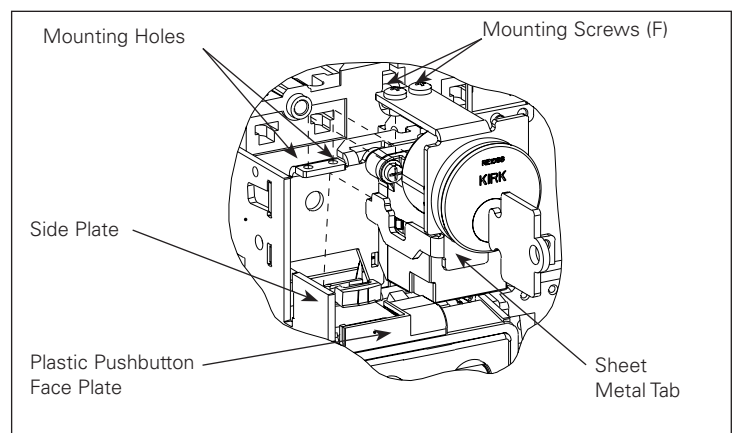

Figure 6. Step 6. NF Frame

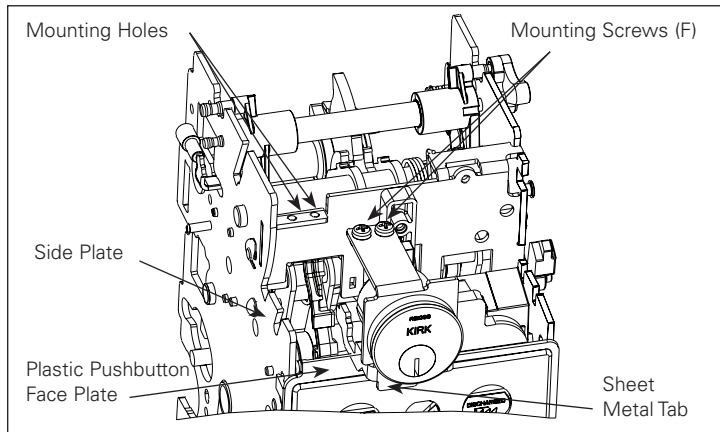

Figure 6a. Step 6. RF Frame

Step 7 (NF Frame Only): If this is a fixed circuit breaker, skip this step and proceed to Step 8. If this is a drawout circuit breaker, put back and re-tighten the three captive secondary mounting bracket screws previously removed in Step 3 of this section starting with the center screw.

Step 8: With the key lock assembly now installed, place the front cover previously removed in Step 2 on an appropriate work surface front side up. Put a rigid support under the round knockout window. Using a punch and a small hammer, carefully punch out the round window in the upper center portion of the front cover. If necessary, use a small file to remove any burrs from the window. Make certain that all pieces and/or particles are cleaned up and removed before proceeding.

Step 9: Replace the front cover, and secure it in place with the mounting screws previously removed in Step 1. Remove the adhesive backing from the External Protective Ring (A) and press it onto the front cover over the key lock.

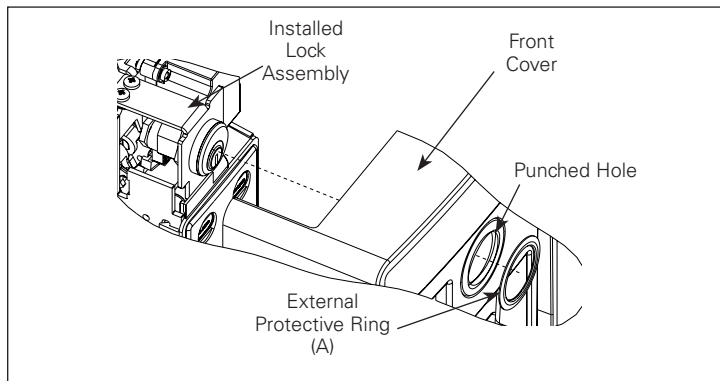

Figure 7. Step 9

Step 10: Perform a functional test:

1. With the key in the cylinder, press the red "Push to Open" button down and rotate the key counterclockwise. Remove the key. Charge the breaker.
2. Push the green "Push to Close" button. The breaker should not close.
3. Insert the key and rotate 90° clockwise. Press the green button to close. The breaker should close.

Section 3: Removal of Key Interlock

To remove the key interlock, perform Steps 1 and 2 of Section 2. Complete the removal process by reversing the process as described in Steps 3 through 7 of Section 2. Replace the front cover.

Installation and Removal Instructions
for Series NRX Kirk Key Interlock Kit

Instruction Leaflet IL01301039E
effective June 2011

Disclaimer of warranties and limitation of liability

The information, recommendations, descriptions, and safety notations in this document are based on Eaton Corporation's ("Eaton") experience and judgment, and may not cover all contingencies. If further information is required, an Eaton sales office should be consulted.

Sale of the product shown in this literature is subject to the terms and conditions outlined in appropriate Eaton selling policies or other contractual agreement between Eaton and the purchaser.

THERE ARE NO UNDERSTANDINGS, AGREEMENTS, WARRANTIES, EXPRESSED OR IMPLIED, INCLUDING WARRANTIES OF FITNESS FOR A PARTICULAR PURPOSE OR MERCHANTABILITY, OTHER THAN THOSE SPECIFICALLY SET OUT IN ANY EXISTING CONTRACT BETWEEN THE PARTIES. ANY SUCH CONTRACT STATES THE ENTIRE OBLIGATION OF EATON. THE CONTENTS OF THIS DOCUMENT SHALL NOT BECOME PART OF OR MODIFY ANY CONTRACT BETWEEN THE PARTIES.

In no event will Eaton be responsible to the purchaser or user in contract, in tort (including negligence), strict liability, or otherwise for any special, indirect, incidental, or consequential damage or loss whatsoever, including but not limited to damage or loss of use of equipment, plant or power system, cost of capital, loss of power, additional expenses in the use of existing power facilities, or claims against the purchaser or user by its customers resulting from the use of the information, recommendations, and descriptions contained herein.

The information contained in this manual is subject to change without notice.

Eaton Corporation
Electrical Group
1000 Cherrington Parkway
Moon Township, PA 15108
United States
877-ETN-CARE (877-386-2273)
Eaton.com

© 2010 Eaton Corporation
All Rights Reserved
Printed in USA
Publication No. IL01301039EH03
June 2011



Power Chain Management is a registered Trademark of Eaton Corporation

All other Trademarks are property of their respective owners.