

# IZM65/67 mechanical interlock

## WARNING

- (1) **ONLY QUALIFIED ELECTRICAL PERSONNEL SHOULD BE PERMITTED TO WORK ON THE EQUIPMENT.**
- (2) **ALWAYS DE-ENERGIZE PRIMARY AND SECONDARY CIRCUITS IF A CIRCUIT BREAKER CANNOT BE REMOVED TO A SAFE WORK LOCATION.**
- (3) **DRAWOUT CIRCUIT BREAKERS SHOULD BE LEVERED (RACKED) OUT TO THE DISCONNECT POSITION.**
- (4) **ALL CIRCUIT BREAKERS SHOULD BE SWITCHED TO THE OFF POSITION AND MECHANISM SPRINGS DISCHARGED.**

**FAILURE TO FOLLOW THESE STEPS FOR ALL PROCEDURES DESCRIBED IN THIS INSTRUCTION LEAFLET COULD RESULT IN DEATH, BODILY INJURY, OR PROPERTY DAMAGE.**

### Section 1: General information

The mechanical interlock is used to interlock between two or three circuit breakers. A mechanical interlock enables one or more circuit breakers to remain in the tripped state (to prevent from being closed).

### Tools required

- Phillips screwdriver
- Knife

### Mechanical interlock for drawout type

### Kit parts identification

- Mechanical interlock (1)
- Screw M5×12 (1)
- Screws M5×8 (4)

### Section 2: Installing the mechanical interlock

Follow below steps for installation:

Step 1: Lever out the basic device for removal, then remove the cover. Mount the pressing plate on the right side of the operating mechanism and secure it with the M5×12 screw.

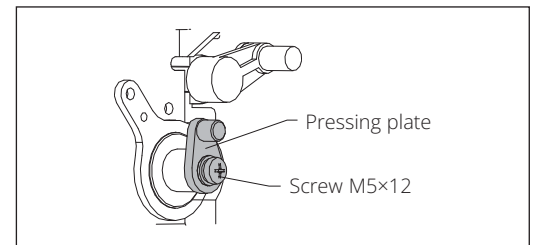

**Figure 1. Step 1**

Step 2: Remove the small square groove, as indicated in the figure, in the cover with the knife, then put the cover back.

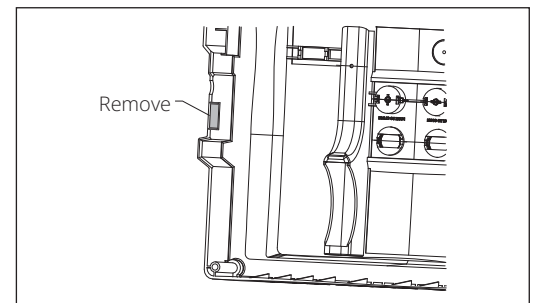

**Figure 2. Step 2**

Step 3: Mount the mechanical interlock onto the right panel and secure it with 4 screws (M5×8). Then, lever the basic device to the Connected position.

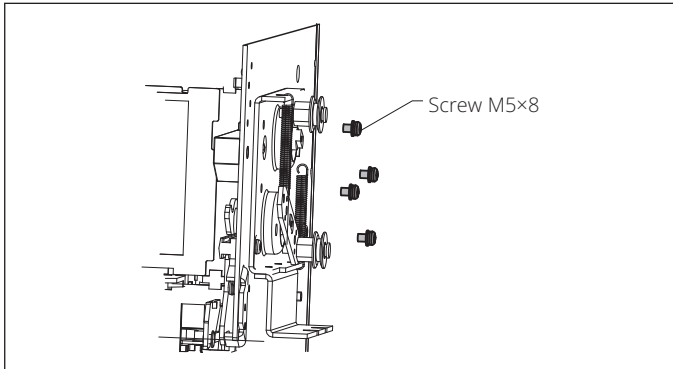

Figure 3. Step 3

Step 4: Mount the other one or two interlocks in the same manner.

### Mechanical interlock for fixed type

#### Kit parts identification

- Mechanical interlock (1)
- Mounting panel (1)
- Screws M5×12 (5)
- Screws M5×8 (4)

### Section 2: Installing the mechanical interlock

Follow below steps for installation:

Step 1: Remove the cover, mount the pressing plate on the right side of the operating mechanism with the M5×12 screw.

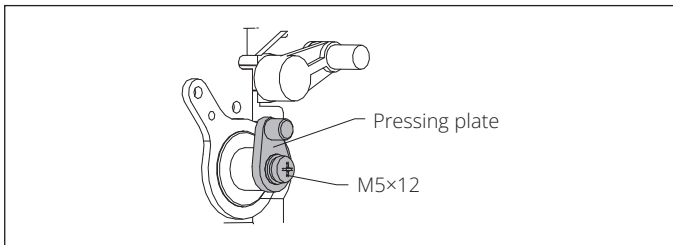

Figure 4. Step 1

Step 2: Remove the small square groove, as indicated in the figure, in the cover with the knife, then put the cover back.

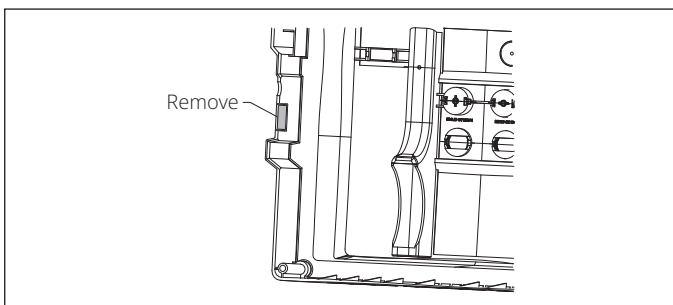

Figure 5. Step 2

Step 3: Secure the mounting panel to the right panel with 4 M5×20 screws.

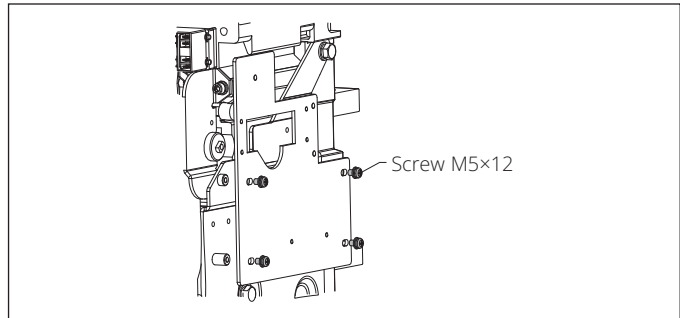

Figure 6. Step 3

Step 4: Mount the mechanical interlock onto the mounting panel with 3 screws (M5×8).

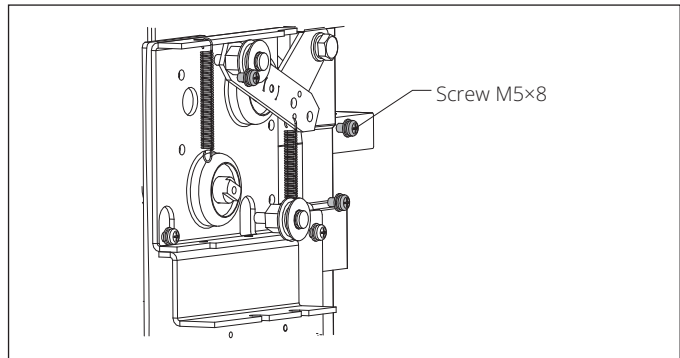

Figure 7. Step 4

Step 5: Mount the other one or two interlocks in the same manner.

### Section 3: Verifying the interlocking between circuit breakers

Interlocking between two circuit breakers:

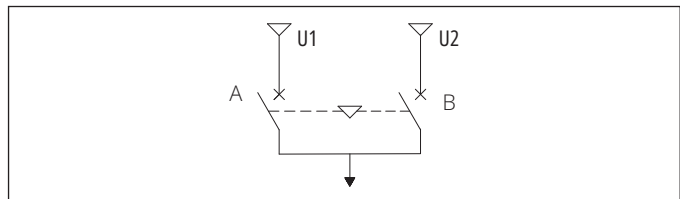
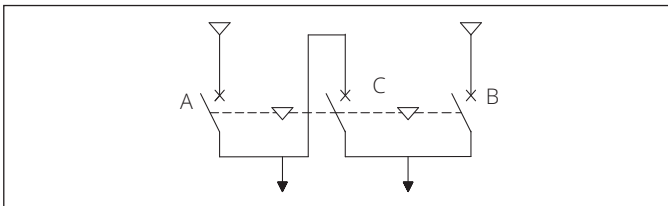

Figure 8: Schematic diagram of two interlocking devices

Both circuit breakers are in the charged status:

- When Circuit Breaker A is closed, Circuit Breaker B cannot be closed; Circuit breaker B can be closed after Circuit Breaker A is opened.
- When Circuit Breaker B is closed, Circuit Breaker A cannot be closed; Circuit breaker A can be closed after Circuit Breaker B is closed.

Interlocking between two circuit breakers:



**Figure 9: Schematic diagram of three interlocking devices**

Three circuit breakers are in the charged status:

- When Circuit Breaker A and B are closed, Circuit Breaker C cannot be closed; Circuit breaker C can be closed after Circuit Breaker A or B is opened.
- When Circuit Breaker A and C are closed, Circuit Breaker B cannot be closed; Circuit breaker B can be closed after Circuit Breaker A or C is opened.
- When Circuit Breaker B and C are closed, Circuit Breaker A cannot be closed; Circuit breaker A can be closed after Circuit Breaker B or C is opened.
- Among Circuit Breaker A, B and C, only one or two circuit breakers can be closed.

## Disclaimer of warranties and limitation of liability

The information, recommendations, descriptions, and safety notations in this document are based on Eaton Corporation's ("Eaton") experience and judgment, and may not cover all contingencies. If further information is required, an Eaton sales office should be consulted.

Sale of the product shown in this literature is subject to the terms and conditions outlined in appropriate Eaton selling policies or other contractual agreement between Eaton and the purchaser.

THERE ARE NO UNDERSTANDINGS, AGREEMENTS, WARRANTIES, EXPRESSED OR IMPLIED, INCLUDING WARRANTIES OF FITNESS FOR A PARTICULAR PURPOSE OR MERCHANTABILITY, OTHER THAN THOSE SPECIFICALLY SET OUT IN ANY EXISTING CONTRACT BETWEEN THE PARTIES. ANY SUCH CONTRACT STATES THE ENTIRE OBLIGATION OF EATON. THE CONTENTS OF THIS DOCUMENT SHALL NOT BECOME PART OF OR MODIFY ANY CONTRACT BETWEEN THE PARTIES.

In no event will Eaton be responsible to the purchaser or user in contract, in tort (including negligence), strict liability, or otherwise for any special, indirect, incidental, or consequential damage or loss whatsoever, including but not limited to damage or loss of use of equipment, plant or power system, cost of capital, loss of power, additional expenses in the use of existing power facilities, or claims against the purchaser or user by its customers resulting from the use of the information, recommendations, and descriptions contained herein.

The information contained in this manual is subject to change without notice.

**Eaton Corporation**  
**Asia Pacific Headquarter**  
No.3, Lane 280, Linhong Road,  
Changning District,  
Shanghai 200335  
Tel: 86-21-52000099  
Fax: 86-21-52000200

© 2023 Eaton  
All Rights Reserved  
Printed in China  
Publication No. IL0131223EN  
March 2023

Eaton is a registered Trademark.

All other trademarks are property of their respective owners.