

# IZM65/67 external auxiliary contact

## WARNING

- (1) **ONLY QUALIFIED ELECTRICAL PERSONNEL SHOULD BE PERMITTED TO WORK ON THE EQUIPMENT.**
- (2) **ALWAYS DE-ENERGIZE PRIMARY AND SECONDARY CIRCUITS IF A CIRCUIT BREAKER CANNOT BE REMOVED TO A SAFE WORK LOCATION.**
- (3) **DRAWOUT CIRCUIT BREAKERS SHOULD BE LEVERED (RACKED) OUT TO THE DISCONNECT POSITION.**
- (4) **ALL CIRCUIT BREAKERS SHOULD BE SWITCHED TO THE OFF POSITION AND MECHANISM SPRINGS DISCHARGED.**

**FAILURE TO FOLLOW THESE STEPS FOR ALL PROCEDURES DESCRIBED IN THIS INSTRUCTION LEAFLET COULD RESULT IN DEATH, BODILY INJURY, OR PROPERTY DAMAGE.**

### Section 1: General information

Auxiliary contacts offer remote indication of whether the circuit breaker is in OFF or ON state. External auxiliary contacts are needed if there are no sufficient internal auxiliary contacts, with a maximum number of 12 ONs and 12 OFFs. Each auxiliary contact has 1 NO contact (Contact "A") and 1 NC contact (Contact "B") with commons.

### Tools required

- Phillips screwdriver
- Plum screws T20
- Knife

### External auxiliary contact installation for drawout products

### Kit parts identification

- Auxiliary contact assembly (1)
- Rail (1)
- Label (1)
- Pressing plate (1)
- Screw M5×12 (1)
- Screw M4×8 (4)

### Section 2: Installing the external auxiliary contact

Follow below steps for installation:

Step 1: First, lever out the basic device to the Disconnected position for removal.

Step 2: Remove the basic device after it is levered out, and remove the cover. Then, mount the pressing plate on the right side of the operating mechanism shaft (with M5×12 screws).

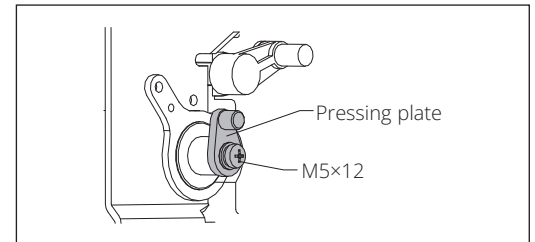

**Figure 1. Step 2**

Step 3: Remove the small square groove, as indicated below, in the cover with the knife, then put the cover back.

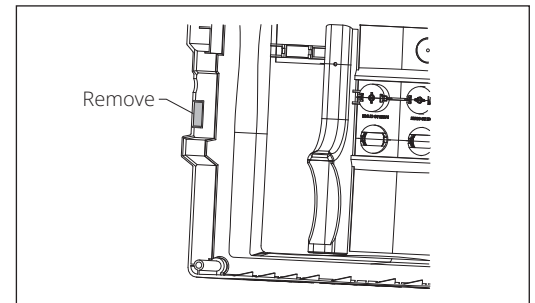

**Figure 2. Step 3**

# EATON

Powering Business Worldwide

Step 4: Mount the auxiliary contacts on the right panel of the cassette and secure them with M4×8 screws (4).

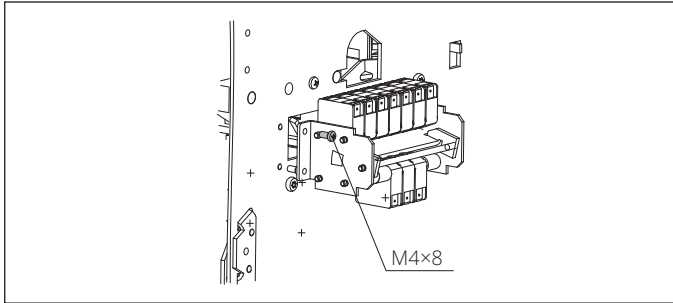

Figure 3. Step 4

Step 5: Remove the screws from the arc extinguishing cover, mount the rail and secure it with screws.

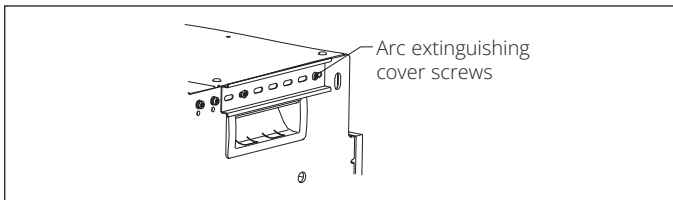

Figure 4. Step 5

Step 6: Then, snap terminals onto the rail in turn, mount the numbering plate, attach the label, and rack the basic device into the Connected position. Then, measure whether it can be switched normally according to the label instructions.

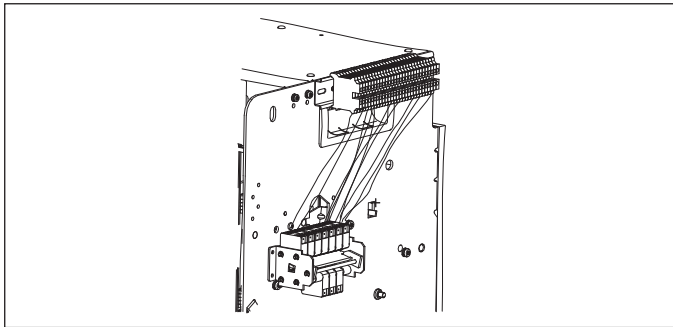

Figure 5. Step 6

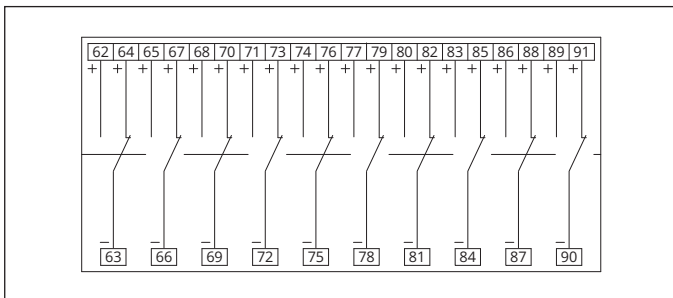

Figure 6. Auxiliary contact label

## External auxiliary contact installation for fixed products

### Kit parts identification

- Auxiliary contact assembly (1)
- Rail (1)
- Label (1)
- Pressing plate (1)
- Mounting panel (1)
- Screw M5×12 (5)
- Screw M4×8 (4)

### Section 2: Installing the external auxiliary contact

Follow below steps for installation:

Step 1: First, rack out the basic device for removal, remove the cover, and mount the pressing plate onto the right side of the operating mechanism (with M5×12 screws).

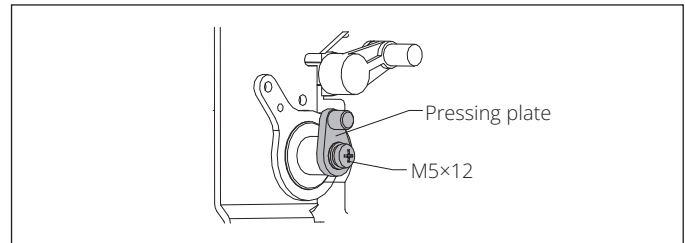

Figure 7. Step 1

Step 2: Remove the small square groove, as indicated in the figure, in the cover with the knife, then put the cover back.

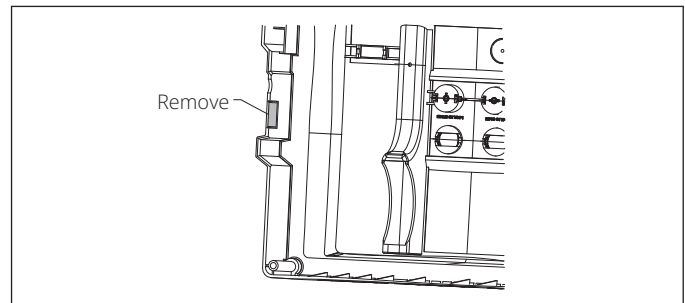

Figure 8. Step 2

Step 3: Secure the fixing plate to the right panel with 4 M5×12 screws.

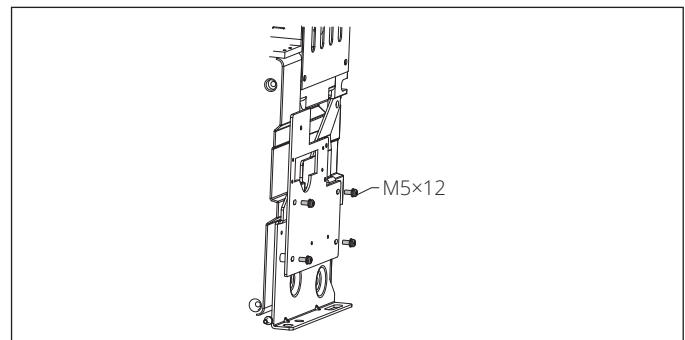

Figure 8. Step 3



## Disclaimer of warranties and limitation of liability

The information, recommendations, descriptions, and safety notations in this document are based on Eaton Corporation's ("Eaton") experience and judgment, and may not cover all contingencies. If further information is required, an Eaton sales office should be consulted.

Sale of the product shown in this literature is subject to the terms and conditions outlined in appropriate Eaton selling policies or other contractual agreement between Eaton and the purchaser.

THERE ARE NO UNDERSTANDINGS, AGREEMENTS, WARRANTIES, EXPRESSED OR IMPLIED, INCLUDING WARRANTIES OF FITNESS FOR A PARTICULAR PURPOSE OR MERCHANTABILITY, OTHER THAN THOSE SPECIFICALLY SET OUT IN ANY EXISTING CONTRACT BETWEEN THE PARTIES. ANY SUCH CONTRACT STATES THE ENTIRE OBLIGATION OF EATON. THE CONTENTS OF THIS DOCUMENT SHALL NOT BECOME PART OF OR MODIFY ANY CONTRACT BETWEEN THE PARTIES.

In no event will Eaton be responsible to the purchaser or user in contract, in tort (including negligence), strict liability, or otherwise for any special, indirect, incidental, or consequential damage or loss whatsoever, including but not limited to damage or loss of use of equipment, plant or power system, cost of capital, loss of power, additional expenses in the use of existing power facilities, or claims against the purchaser or user by its customers resulting from the use of the information, recommendations, and descriptions contained herein.

The information contained in this manual is subject to change without notice.

**Eaton Corporation**  
**Asia Pacific Headquarter**  
No.3, Lane 280, Linhong Road,  
Changning District,  
Shanghai 200335  
Tel: 86-21-52000099  
Fax: 86-21-52000200

© 2023 Eaton  
All Rights Reserved  
Printed in China  
Publication No. IL0131220EN  
March 2023

Eaton is a registered Trademark.

All other trademarks are property of their respective owners.