

IZM61 position cell switch

WARNING

- (1) **ONLY QUALIFIED ELECTRICAL PERSONNEL SHOULD BE PERMITTED TO WORK ON THE EQUIPMENT.**
- (2) **ALWAYS DE-ENERGIZE PRIMARY AND SECONDARY CIRCUITS IF A CIRCUIT BREAKER CANNOT BE REMOVED TO A SAFE WORK LOCATION.**
- (3) **DRAWOUT CIRCUIT BREAKERS SHOULD BE LEVERED (RACKED) OUT TO THE DISCONNECT POSITION.**
- (4) **ALL CIRCUIT BREAKERS SHOULD BE SWITCHED TO THE OFF POSITION AND MECHANISM SPRINGS DISCHARGED.**

FAILURE TO FOLLOW THESE STEPS FOR ALL PROCEDURES DESCRIBED IN THIS INSTRUCTION LEAFLET COULD RESULT IN DEATH, BODILY INJURY, OR PROPERTY DAMAGE.

Section 1: General information

Three sets of switches are available to indicate separately the current position of the circuit breaker (Connected, Test, Disconnected). The corresponding switch will be switched on when the circuit breaker is in a certain position.

Tools required

- Phillips screwdriver

Kit parts identification

- Position cell switch (1)
- Label (1)
- Screws M4×8 (5)
- Rail 60mm

Section 2: Installing the position cell switch

Follow below steps for installation:

Step 1: First, lever out the basic device to the Disconnected position for removal.

Step 2: Place the position cell switch onto the left side panel of the cassette, and secure it with M4×8 screws. Attach the label above the measuring position after mounting.

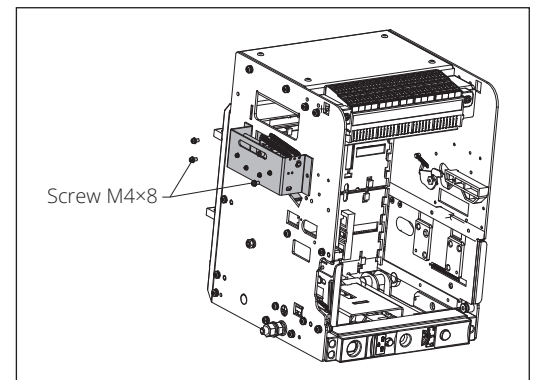

Figure 1. Step 2

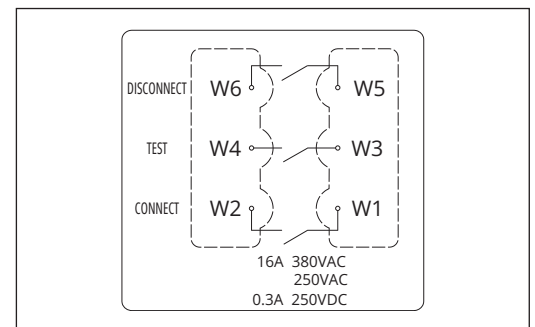

Figure 2. Step 2 label

EATON

Powering Business Worldwide

Step 3: Mount the rail and secure it with M4×8 screws.

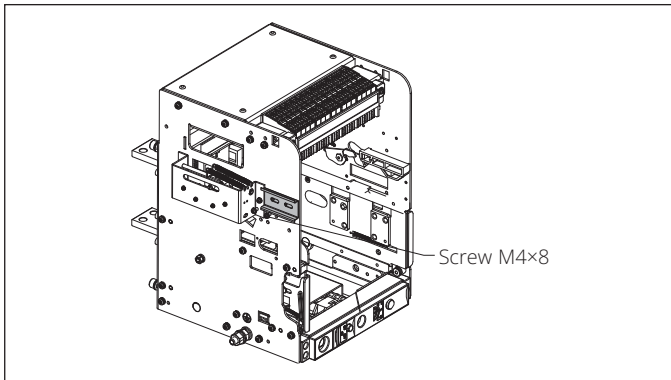

Figure 3. Step 3

Step 4: Then connect the position cell switch wires to the terminals and fasteners by number, and mount terminal number plate.

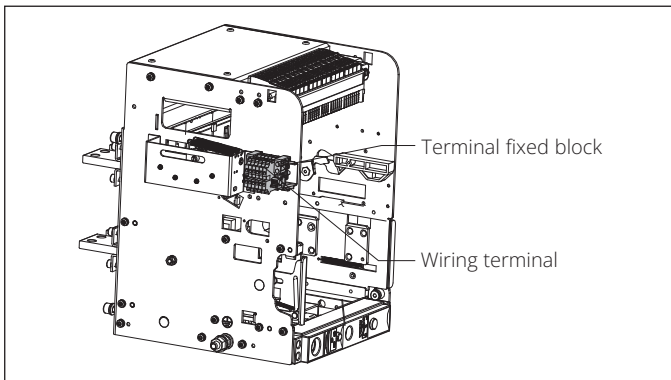

Figure 4. Step 4

Step 5: Finally, put the basic device back into the cassette, and measure whether the corresponding switch at the three positions can be properly switched on.

Disclaimer of warranties and limitation of liability

The information, recommendations, descriptions, and safety notations in this document are based on Eaton Corporation's ("Eaton") experience and judgment, and may not cover all contingencies. If further information is required, an Eaton sales office should be consulted.

Sale of the product shown in this literature is subject to the terms and conditions outlined in appropriate Eaton selling policies or other contractual agreement between Eaton and the purchaser.

THERE ARE NO UNDERSTANDINGS, AGREEMENTS, WARRANTIES, EXPRESSED OR IMPLIED, INCLUDING WARRANTIES OF FITNESS FOR A PARTICULAR PURPOSE OR MERCHANTABILITY, OTHER THAN THOSE SPECIFICALLY SET OUT IN ANY EXISTING CONTRACT BETWEEN THE PARTIES. ANY SUCH CONTRACT STATES THE ENTIRE OBLIGATION OF EATON. THE CONTENTS OF THIS DOCUMENT SHALL NOT BECOME PART OF OR MODIFY ANY CONTRACT BETWEEN THE PARTIES.

In no event will Eaton be responsible to the purchaser or user in contract, in tort (including negligence), strict liability, or otherwise for any special, indirect, incidental, or consequential damage or loss whatsoever, including but not limited to damage or loss of use of equipment, plant or power system, cost of capital, loss of power, additional expenses in the use of existing power facilities, or claims against the purchaser or user by its customers resulting from the use of the information, recommendations, and descriptions contained herein.

The information contained in this manual is subject to change without notice.

Eaton Corporation
Asia Pacific Headquarter
No.3, Lane 280, Linhong Road,
Changning District,
Shanghai 200335
Tel: 86-21-52000099
Fax: 86-21-52000200

© 2023 Eaton
All Rights Reserved
Printed in China
Publication No. IL0131208EN
March 2023

Eaton is a registered Trademark.

All other trademarks are property of their respective owners.