



Cutler-Hammer

Profibus DP Option Board for 9000X Drive

User Manual

New Information
March 2004



March 2004

Important Notice – Please Read

The product discussed in this literature is subject to terms and conditions outlined in Eaton Electrical Inc. selling policies. The sole source governing the rights and remedies of any purchaser of this equipment is the relevant Eaton Electrical Inc. selling policy.

NO WARRANTIES, EXPRESS OR IMPLIED, INCLUDING WARRANTIES OF FITNESS FOR A PARTICULAR PURPOSE OR MERCHANTABILITY, OR WARRANTIES ARISING FROM COURSE OF DEALING OR USAGE OF TRADE, ARE MADE REGARDING THE INFORMATION, RECOMMENDATIONS AND DESCRIPTIONS CONTAINED HEREIN. In no event will Eaton Electrical Inc. be responsible to the purchaser or user in contract, in tort (including negligence), strict liability or otherwise for any special, indirect, incidental or consequential damage or loss whatsoever, including but not limited to damage or loss of use of equipment, plant or power system, cost of capital, loss of power, additional expenses in the use of existing power facilities, or claims against the purchaser or user by its customers resulting from the use of the information, recommendations and descriptions contained herein.

The information contained in this manual is subject to change without notice.

Cover Photo: Cutler-Hammer® 9000X Drives.

Table of Contents

LIST OF FIGURES	iii
LIST OF TABLES	iii
CHAPTER 0 — SAFETY	iv
Definitions and Symbols	iv
Hazardous High Voltage	iv
Warnings and Cautions	v
CHAPTER 1 — GENERAL	1-1
CHAPTER 2 — PROFIBUS DP OPTION BOARD TECHNICAL DATA	2-1
General	2-1
Profibus Cable	2-1
CHAPTER 3 — PROFIBUS DP	3-1
Introduction	3-1
Profiles	3-1
CHAPTER 4 — PROFIBUS FIELDING BOARD LAYOUT AND CONNECTIONS	4-1
Profibus OPTC3 Option Board	4-1
Profibus OPTC5 Option Board	4-5
Bus Terminal Resistors	4-6
LED Indications	4-6
CHAPTER 5 — INSTALLATION OF PROFIBUS BOARD	5-1
CHAPTER 6 — COMMISSIONING	6-1
Fieldbus Board Parameters	6-1
Start-Up Test	6-3
CHAPTER 7 — PROFIBUS-9000X DRIVE INTERFACE	7-1
General	7-1
Operation Mode	7-1
PPO Types	7-2
Process Data	7-3
Parameter Data	7-8
Example Messages	7-10
CHAPTER 8 — FAULT TRACKING	8-1
CHAPTER 9 — TYPE FILES	9-1
GSD-file (“Profibus Support Disk” files: vac29500.GSD, vac29500.GSE)	9-1
APPENDIX A — PROCESS DATA	A-1
Process Data OUT (Slave → Master)	A-1
Process Data IN (Master → Slave)	A-1

March 2004

List of Figures

Figure 2-1: Cabling and Bus Termination	2-2
Figure 4-1: Profibus Option Board OPTC3	4-1
Figure 4-2: Grounding with RC Filter	4-3
Figure 4-3: Grounding by Clamping the Cable to the Drive Frame	4-4
Figure 4-4: Profibus Option Board OPTC5	4-5
Figure 4-5: Using Jumper X6 to Set the Bus Termination	4-6
Figure 4-6: LED Indications on the Profibus Board	4-6
Figure 6-1: Changing the Profibus Board Commissioning Parameter Values	6-1
Figure 6-2: Profibus Status	6-2
Figure 7-1: Data Transfer Between Profibus Master and Slaves	7-1
Figure 7-2: Control of the Drive Through Profibus	7-3
Figure 7-3: State Machine	7-6
Figure 7-4: Control of Process Data	7-8
Figure 7-5: Transfer of Parameter Data	7-8

List of Tables

Table 2-1: Profibus Technical Data	2-1
Table 2-2: Line Parameters	2-2
Table 2-3: Line Length for Different Transmission Speeds	2-2
Table 4-1: OPTC3 Bus Connector Signals	4-1
Table 4-2: Grounding the Bus Cable Shield Directly to the Drive Frame	4-2
Table 4-3: Grounding the Bus Cable Shield Using RC Filter	4-4
Table 4-4: Grounding by Clamping the Cable to the Drive Frame	4-4
Table 4-5: OPTC3 Bus Connector Signals	4-5
Table 4-6: Profibus Status LED (PS) — RED	4-7
Table 4-7: Profibus Status LED (BS) — YELLOW	4-7
Table 4-8: Profibus Status LED (FS) — GREEN	4-7
Table 5-1: Installing the Profibus Board	5-1
Table 6-1: Profibus Parameters	6-2
Table 6-2: Profibus Status Indications	6-2
Table 7-1: Control Word Bit Descriptions	7-4
Table 7-2: Commands with Control Word	7-4
Table 7-3: Status Word Bit Descriptions	7-5
Table 7-4: Grouping of ID Numbers	7-9
Table 7-5: Request/Response Types	7-9
Table 7-6: Fault Numbers (If Response = 7)	7-9
Table 8-1: Profibus Option Board Faults	8-1
Table 8-2: Drive Responses to Faults	8-1
Table A-1: Process Data OUT for All Applications	A-1
Table A-2: Process Data IN for Basic, Standard, Local/Remote, Multi-Step Applications	A-1
Table A-3: Process Data IN for Multipurpose Control Application	A-1
Table A-4: Process Data IN for PID Control and Pump and Fan Control Applications	A-2

Safety

Definitions and Symbols

 **WARNING**

This symbol indicates high voltage. It calls your attention to items or operations that could be dangerous to you and other persons operating this equipment. Read the message and follow the instructions carefully.



This symbol is the "Safety Alert Symbol." It occurs with either of two signal words: CAUTION or WARNING, as described below.

 **WARNING**

Indicates a potentially hazardous situation which, if not avoided, can result in serious injury or death.

 **CAUTION**

Indicates a potentially hazardous situation which, if not avoided, can result in minor to moderate injury, or serious damage to the product. The situation described in the CAUTION may, if not avoided, lead to serious results. Important safety measures are described in CAUTION (as well as WARNING).

Hazardous High Voltage

 **WARNING**

Motor control equipment and electronic controllers are connected to hazardous line voltages. When servicing drives and electronic controllers, there may be exposed components with housings or protrusions at or above line potential. Extreme care should be taken to protect against shock.

Stand on an insulating pad and make it a habit to use only one hand when checking components. Always work with another person in case an emergency occurs. Disconnect power before checking controllers or performing maintenance. Be sure equipment is properly grounded. Wear safety glasses whenever working on electronic controllers or rotating machinery.

March 2004

Warnings and Cautions

 WARNING

Internal components and circuit boards are at high potential when the drive is connected to the power source. This voltage is extremely dangerous and may cause death or severe injury if you come into contact with it.

 CAUTION

DO NOT add or replace option boards or fieldbus boards on a drive with the power switched ON! This may damage the boards.

March 2004

Chapter 1 — General

Cutler-Hammer® 9000X drives from Eaton Electrical® can be connected to the Profibus DP using a fieldbus board. The drive can then be controlled, monitored and programmed from the Host system.

The Profibus fieldbus board shall be installed in slot E on the control board of the drive.

 WARNING

Internal components and circuit boards are at high potential when the drive is connected to the power source. This voltage is extremely dangerous and may cause death or severe injury if you come into contact with it.

March 2004

Chapter 2 — Profibus DP Option Board Technical Data

General

Table 2-1: Profibus Technical Data

Description	Specification
Profibus DP Connections	
Interface	OPTC3: Pluggable connector (5.08 mm) OPTC5: 9-pin DSUB connector (female)
Data transfer method	RS-485, half-duplex
Transfer cable	Twisted pair (1 pair and shield)
Electrical isolation	500V DC
Communications	
Profibus DP	As described in document "Profibus Profile for variable speed drives, Profidrive"
PPO types	1, 2, 3, 4, 5
Baud rate	9.6 kbaud to 12 Mbaud
Addresses	2 to 126
Environment	
Ambient operating temperature	-10°C – 55°C
Storing temperature	-40°C – 60°C
Humidity	<95%, no condensation allowed
Altitude	Max. 1000m
Vibration	0.5G at 9 – 200 Hz
Safety	Fulfils EN 50178 standard

Profibus Cable

Profibus devices are connected in a bus structure. Up to 32 stations (master or slaves) can be connected in one segment. The bus is terminated by an active bus terminator at the beginning and end of each segment (see **Figure 2-1**). To ensure error-free operation, both bus terminations must always be powered. When more than 32 stations are used, repeaters (line amplifiers) must be used to connect the individual bus segments.

The maximum cable length depends on the transmission speed and cable type (see **Table 2-3**). The specified cable length can be increased using the repeaters. The use of more than three repeaters in series is not recommended.

Table 2-2: Line Parameters

Parameter	Line A	Line B
Impedance	135 – 165Ω (3 to 20 MHz)	100 – 130Ω (f > 100 kHz)
Capacity	< 30 pF/m	< 60 pF/m
Resistance	< 110Ω / km	—
Wire gauge	> 0.64 mm	> 0.53 mm
Conductor area	> 0.34 mm ²	> 0.22 mm ²

Table 2-3: Line Length for Different Transmission Speeds

Line	Length for Baud Rate (kbit/S)						
	9.6	19.2	93.75	187.5	500	1500	3000 – 12000
Line A in ft. (m)	3940 (1200)	3940 (1200)	3940 (1200)	3280 (1000)	1310 (400)	660 (200)	330 (100)
Line B in ft. (m)	3940 (1200)	3940 (1200)	3940 (1200)	1970 (600)	660 (200)	—	—

E.g. following cables can be used:

- Belden** Profibus Data Cable 3079A
- Olflex** Profibus Cable 21702xx
- Siemens** SINEC L2 LAN cable for Profibus 6XV1 830-0AH10

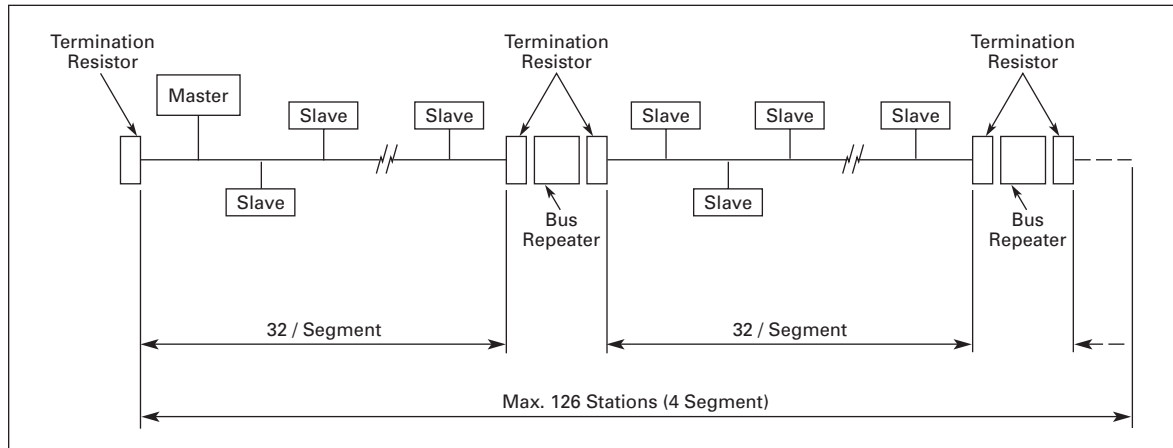

Figure 2-1: Cabling and Bus Termination

March 2004

Chapter 3 — Profibus DP

Introduction

Profibus is a vendor-independent, open fieldbus standard for a wide range of applications in manufacturing, process and building automation. Vendor independence and openness are guaranteed by the Profibus standard EN 50 170. With Profibus, devices of different manufacturers can communicate without special interface adjustments. Profibus can be used for both high-speed time critical data transmission and extensive complex communication tasks. The Profibus family consists of three compatible versions.

Profibus DP

Optimized for high speed and inexpensive hookup, this Profibus version is designed especially for communication between automation control systems and distributed I/O at the device level. Profibus DP can be used to replace parallel signal transmission with 24V or 0 to 20 mA.

Profibus PA

Profibus PA is designed especially for process automation. It permits sensors and actuators to be connected on one common bus line even in intrinsically-safe areas. Profibus PA permits data communication and power over the bus using a 2-wire technology according to the international standard IEC 1158-2.

Profibus FMS

Profibus FMS is the general-purpose solution for communication tasks at the cell level. Powerful FMS services open up a wide range of applications and provide great flexibility. Profibus FMS can also be used for extensive and complex communication tasks.

The Profibus Family

Profibus specifies the technical and functional characteristics of a serial fieldbus system with which decentralized digital controllers can be networked together from the field level to the cell level. Profibus distinguishes between master devices and slave devices.

Master devices determine the data communication on the bus. A master can send messages without an external request when it holds the bus access rights (the token). Masters are also called “active stations” in the Profibus protocol.

Slave devices are peripheral devices. Typical slave devices include input/output devices, valves, drives and measuring transmitters. They do not have bus access rights and they can only acknowledge received messages or send messages to the master when requested to do so. Slaves are also called “passive stations”.

Profiles

The Profibus DP protocol defines how user data are to be transmitted between the stations over the bus. User data are not evaluated by the Profibus DP transmission protocol. The meaning is specified in the profiles. In addition, the profiles specify how Profibus DP is to be used in the application area. The following Profibus DP profile is used in the Cutler-Hammer Profibus Fieldbus board.

Variable Speed Drive Profile (3.071)

Leading manufacturers of drive technology have jointly defined the PROFIDRIVE profile. The profile specifies how the drives are to be parameterized and how the setpoints and actual values are to be transmitted. This enables drives from different vendors to be exchanged. The profile contains necessary specifications for speed control and positioning. It specifies the basic drive functions while leaving sufficient freedom for application-specific expansions and further developments. The profile describes the mapping of the application functions for DP or FMS.

March 2004

Chapter 4 — Profibus Fielding Board Layout and Connections

The Cutler-Hammer Profibus Fieldbus Board from Eaton Electrical is connected to the fieldbus through either a 5-pin pluggable bus connector (board OPTC3) or a 9-pin female sub-D-connector (board OPTC5).

The communication with the control board takes place through the standard Interface Board Connector.

Profibus OPTC3 Option Board

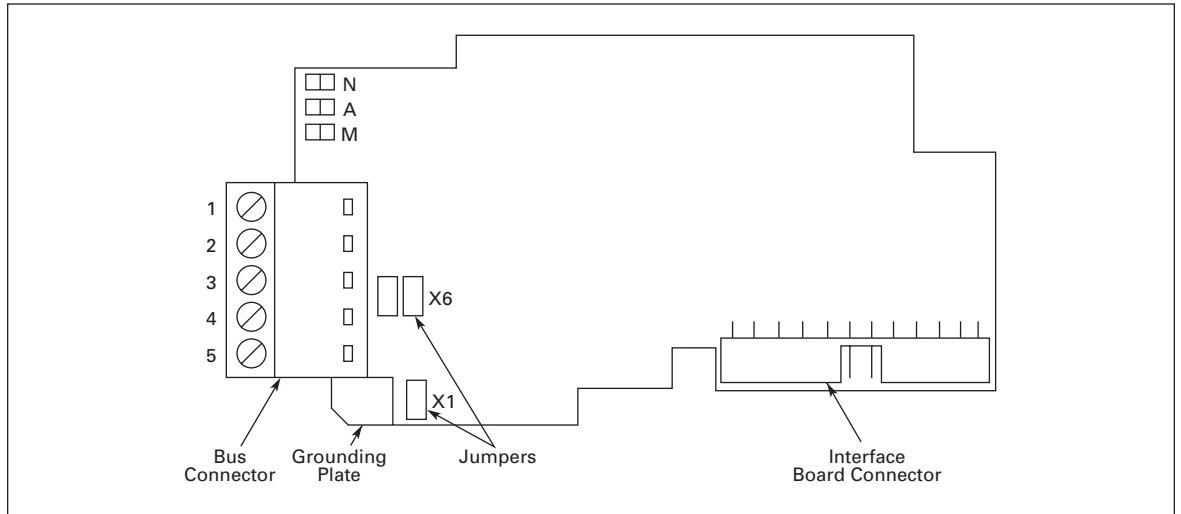

Figure 4-1: Profibus Option Board OPTC3

Table 4-1: OPTC3 Bus Connector Signals

Signal	Connector	Description
Shield	1	Cable shield
VP	2	Supply voltage – plus (5V)
RxD/TxD -P	3	Receive/Transmit data – plus (B)
RxD/TxD -N	4	Receive/Transmit data – minus (A)
DGND	5	Data ground (reference potential for VP)

Grounding of Bus Cable Shield in OPTC3



The bus cable shield can be grounded in three different ways:

1. directly to the drive frame
2. to the frame of the drive through an RC filter
3. clamping the cable to the drive frame (recommended)

Note: Normally, the option board has already been installed in slot E of the control board. It is not necessary to detach the whole board for the grounding of the bus cable shield. Just detach the terminal block.

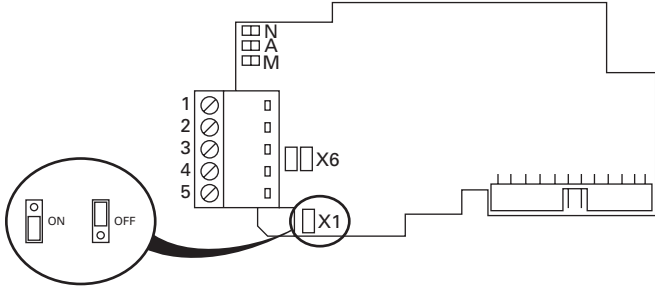

Grounding the Bus Cable Shield Directly to the Drive Frame Using Jumper X1

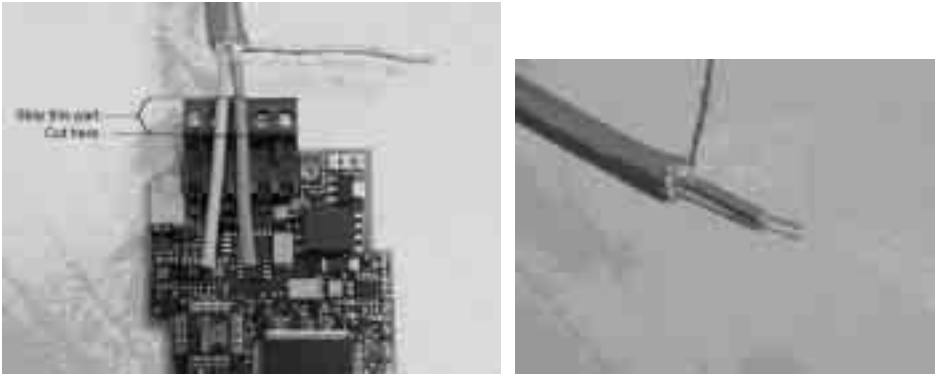
Table 4-2: Grounding the Bus Cable Shield Directly to the Drive Frame

Step	Procedure
1	<p>Set jumper X1 in ON position:</p> 
2	<p>Strip about 2 Inches (50 mm) of the Profibus cable as shown in the picture.</p> <p>Note: Do the same for both bus cables (except for the last device). However, since the grounding shall be done on one cable only, cut off the exposed part of the other grounding cable.</p> 
3	<p>Leave no more than 3/8 Inch (10 mm) of the red and green data cable outside the terminal block and strip the data cables at about 3/16 Inch (5 mm) to fit in the terminals. See pictures below.</p> <p>Note: Do this for both bus cables.</p> 

March 2004

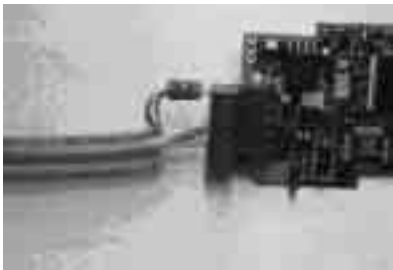
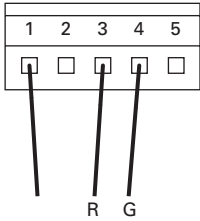
Table 4-2: Grounding the Bus Cable Shield Directly to the Drive Frame, continued

Step	Procedure
<p>4</p>	<p>We recommend that you use an Abico connector to fit the grounding cable into the grounding terminal (#1).</p> <p>Insert the red and green data cables of both Profibus cables into terminals #3 (red) and #4 (green).</p>  
<p>5</p>	<p>Place the Profibus board into slot E of the control board (see board installation on Page 5-1 and fix both the Profibus cables on the frame with the clamp.</p> 

Grounding the Bus Cable Shield Directly to the Drive Frame Using an RC Filter

We recommend you to do the grounding in this manner when the distance between the devices exceeds 55 yds. (50m). When the distance between the devices is long, disturbances (e.g. voltage spikes) are more likely to appear. In this grounding method, the disturbances are filtered out. Even if the ground planes of A, B and C are different (which is very typical e.g. in construction) there is no current between them because the points do not have a ground connection.

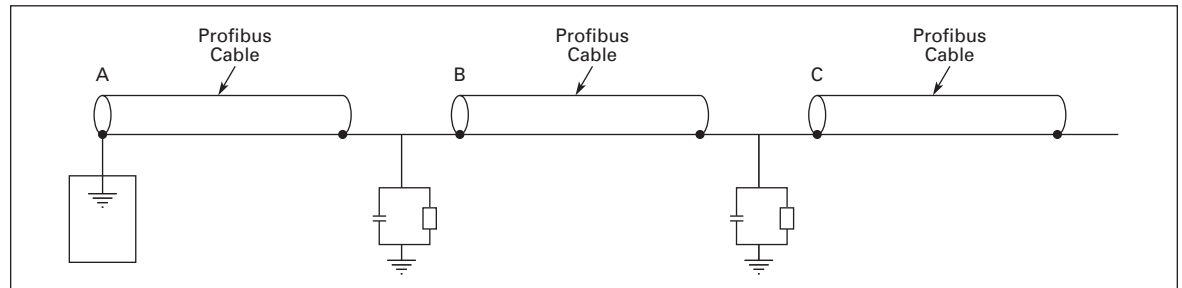
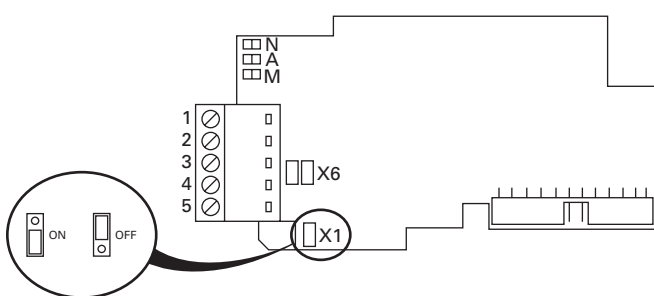

Figure 4-2: Grounding with RC Filter

Table 4-3: Grounding the Bus Cable Shield Using RC Filter

Step	Procedure
1	Set jumper X1 in OFF position: 
2	Carry out the grounding in the same way as advised in Table 4-2 .

Grounding by Clamping the Cable to the Drive Frame

This manner of grounding is the most effective and especially recommended when the distances between the devices are relatively short (see **Page 4-3**).

In this manner of grounding, the position of jumper X1 is of no importance.

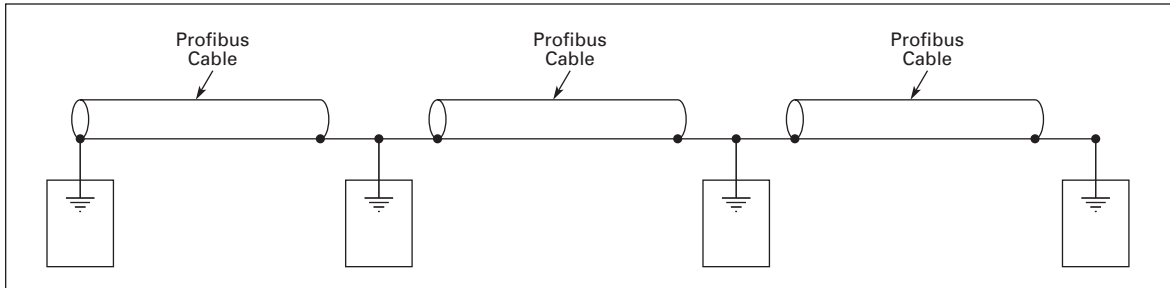

Figure 4-3: Grounding by Clamping the Cable to the Drive Frame

Table 4-4: Grounding by Clamping the Cable to the Drive Frame

Step	Procedure
1	Strip about 2 Inches (50 mm) of the Profibus cable in the same way as shown in Table 4-2 but cut off the gray cable shield . Remember to do this for both bus cables (except for the last device).
2	Leave no more than 3/8 Inch (10 mm) of the red and green data cable outside the terminal block and strip the data cables at about 3/16 Inch (5 mm) to fit in the terminals. See Table 4-2 . Note: Do this for both bus cables.
3	Insert the red and green data cables of both Profibus cables into terminals #3 (red) and #4 (green). See Table 4-2 .

March 2004

Table 4-4: Grounding by Clamping the Cable to the Drive Frame, continued

Step	Procedure
4	Strip the Profibus cable at such a distance from the terminal that you can fix it to the frame with the grounding clamp. See pictures below.

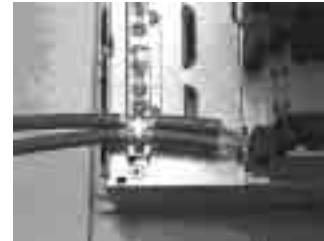

Profibus OPTC5 Option Board

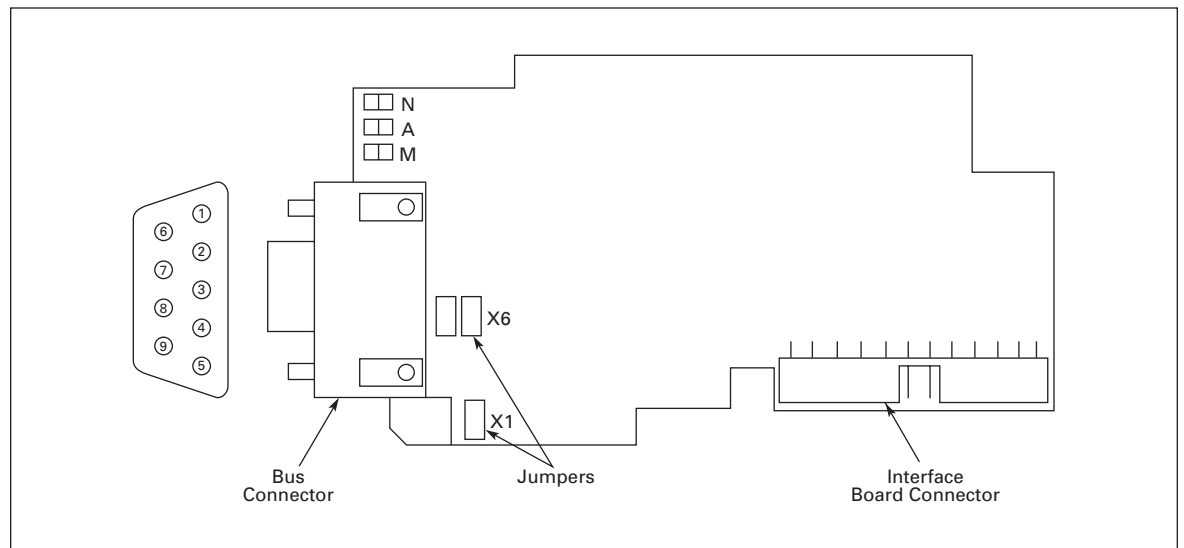

Figure 4-4: Profibus Option Board OPTC5

Table 4-5: OPTC3 Bus Connector Signals

Signal	Connector	Description
Shield	1	Cable shield
RxD/TxD -P	3	Receive/Transmit data – plus (B), RED
DGND	5	Data ground (reference potential for VP)
VP	6	Supply voltage – plus (5V)
RxD/TxD -N	8	Receive/Transmit data – minus (A), GREEN

Recommendation: Use D-sub connector type Siemens 6GK1500-0EA02 with a straight cable outlet.

Bus Terminal Resistors

If the drive is the last device of the Profibus line, the bus termination must be set. Use jumper X6 (ON position) or external termination resistors (e.g. in DSUB-9 connector). See **Figure 4-5**.

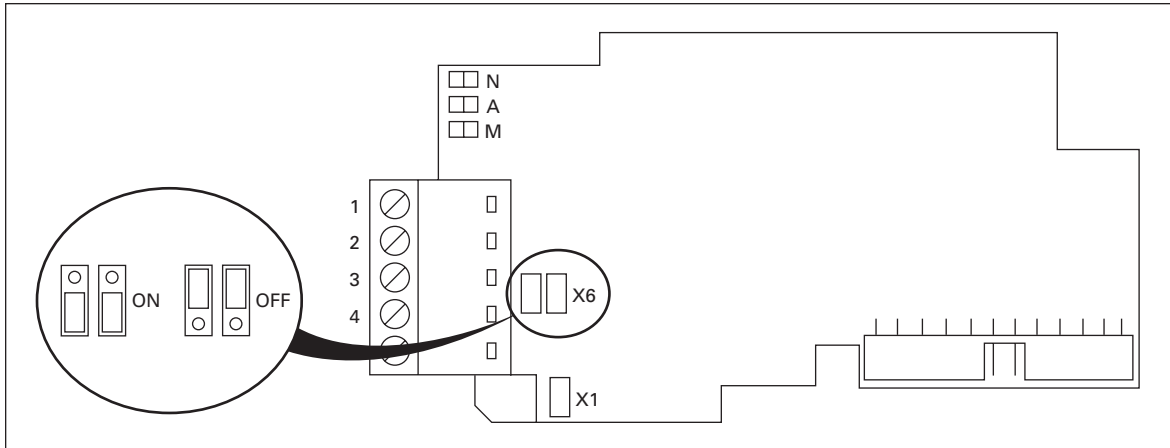

Figure 4-5: Using Jumper X6 to Set the Bus Termination

LED Indications

The three LED indications next to the connector show the present statuses of the Profibus (red), the Profibus board (yellow) and the Fieldbus Module (green). From the user's viewpoint, the first two are the most significant.

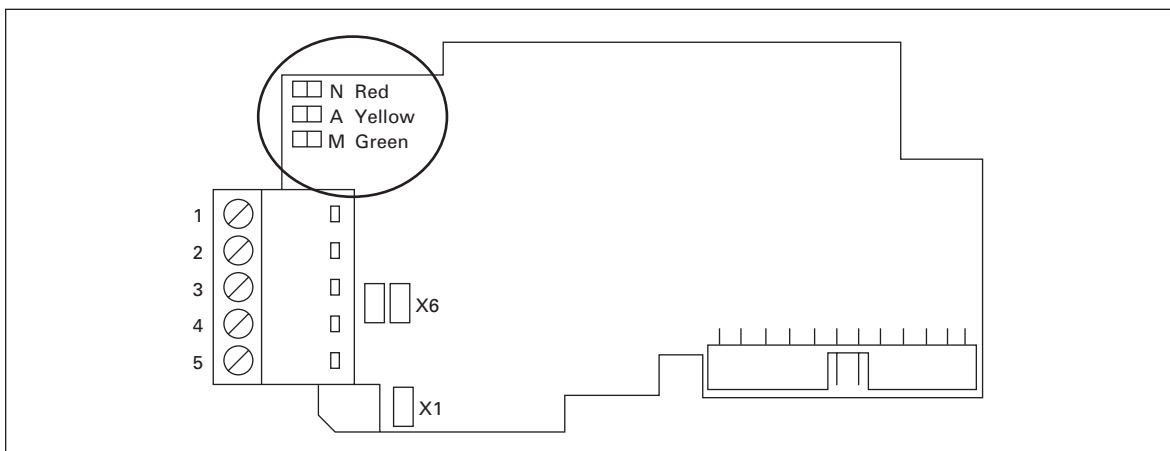

Figure 4-6: LED Indications on the Profibus Board

March 2004

Table 4-6: Profibus Status LED (PS) — RED

LED is:	Meaning:
OFF	Profibus communicates normally. <ul style="list-style-type: none"> • Data exchange between Master and Slave
ON	Profibus communication is broken or not started. <ul style="list-style-type: none"> • Bus cable broken or incorrectly connected • Wrong configuration or parametrization data of Master • Master is off line or shut down

Table 4-7: Profibus Status LED (BS) — YELLOW

LED is:	Meaning:
OFF	Option board not activated
ON	Option board in initialization state waiting for activation command from the drive
Blinking fast (once/sec)	Option board is activated and in RUN state <ul style="list-style-type: none"> • Option board is ready for external communication
Blinking slow (once/5 secs)	Option board is activated and in FAULT state <ul style="list-style-type: none"> • Internal fault of option board

Table 4-8: Profibus Status LED (FS) — GREEN

LED is:	Meaning:
OFF	Fieldbus module is waiting for parameters from the drive <ul style="list-style-type: none"> • No external communication
ON	Fieldbus module is activated <ul style="list-style-type: none"> • Parameters received and module activated • Module is waiting for messages from the bus
Blinking fast (once/sec)	Module is activated and receiving messages from the bus
Blinking slow (once/5 secs)	Module is in FAULT state <ul style="list-style-type: none"> • No messages from Master within the watchdog time • Bus broken, cable loose or Master off line

March 2004

Chapter 5 — Installation of Profibus Board

⚠ CAUTION

DO NOT add or replace option boards or fieldbus boards on a drive with the power switched ON! This may damage the boards.

Table 5-1: Installing the Profibus Board







Step	Procedure
A	9000X Adjustable Frequency Drive. 
B	Remove the cable cover. 
C	Open the cover of the control unit. 

Table 5-1: Installing the Profibus Board, continued

Step	Procedure
<p>D</p>	<p>Install Profibus DP option board in slot E on the control board of the drive. Make sure that the grounding plate (see below) fits tightly in the clamp.</p>  
<p>E</p>	<p>Make a sufficiently wide opening for your cable by cutting the grid as wide as necessary.</p> 
<p>F</p>	<p>Close the cover of the control unit and the cable cover.</p> 

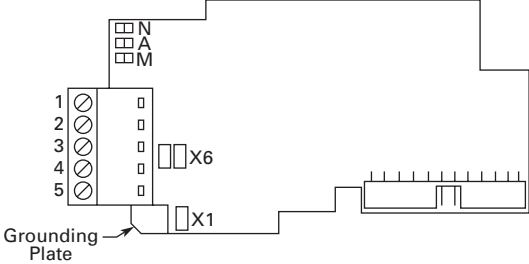
March 2004

Chapter 6 — Commissioning

Read first about Menu Navigation in the 9000X user's manual.

Fieldbus Board Parameters

The Profibus board is commissioned with the control keypad by giving values to appropriate parameters in menu **M7** (for locating the expander board menu see the 9000X user's manual).

Expander Board Menu (M7)

The Expander board menu makes it possible for the user 1) to see what expander boards are connected to the control board and 2) to reach and edit the parameters associated with the expander board.

Enter the following menu level (**G#**) with the *menu button right*. At this level, you can browse through slots A to E with the *browser buttons* to see what expander boards are connected. On the lowermost line of the display, you also see the number of parameter groups associated with the board.

If you still press the menu button right once, you will reach the parameter group level where there are two groups: Editable parameters and Monitored values. A further press on the *menu button right* takes you to either of these groups.

Profibus Parameters

To commission the Profibus board, enter the level G7.5.1.# from the Parameters group (G7.5.1). Give desired values to all Profibus parameters (see **Figure 6-1** and **Table 6-1**).

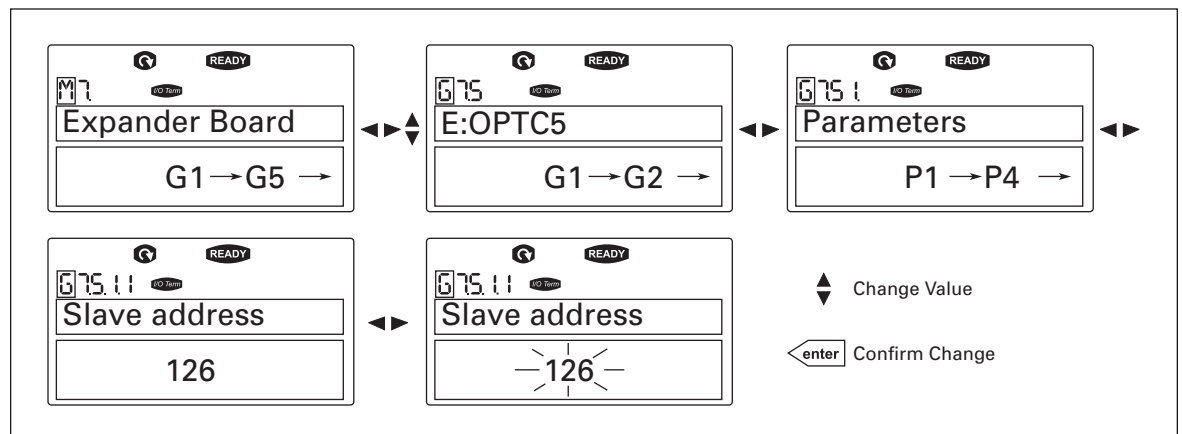

Figure 6-1: Changing the Profibus Board Commissioning Parameter Values

Table 6-1: Profibus Parameters

#	Name	Default	Range	Description
1	SLAVE ADDRESS	126	2 – 126	
2	BAUD RATE	10 (=AUTO)	1 = 9.6 kBaud 2 = 19.2 kBaud 3 = 93.75 kBaud 4 = 187.5 kBaud 5 = 500 kBaud 6 = 1.5 Mbaud 7 = 3 MBaud 8 = 6 Mbaud 9 = 12 Mbaud 10 = AUTOMATIC	Communication speed in baud
3	PPO TYPE		1 = PPO1 2 = PPO2 3 = PPO3 4 = PPO4 5 = PPO5	Parameter, CW/SW, Ref/Act Parameter, CW/SW, Ref/Act, PD1-PD4 CW/SW, Ref/Act CW/SW, Ref/Act, PD1-PD4 Parameter, CW/SW, Ref/Act, PD1-PD8
4	OPERATE MODE		1 = PROFIDRIVE 2 = BYPASS 3 = ECHO	Use mode "PROFIDRIVE" with standard applications

The parameters of every device must be set before connecting to the bus. Especially the parameters "SLAVE ADDRESS" and "PPO TYPE" must be the same as in the master configuration.

Profibus Status

To see the present status of the Profibus fieldbus, enter the Profibus status page from Monitor menu (G7.5.2). See **Figure 6-2** and **Table 6-2** below.

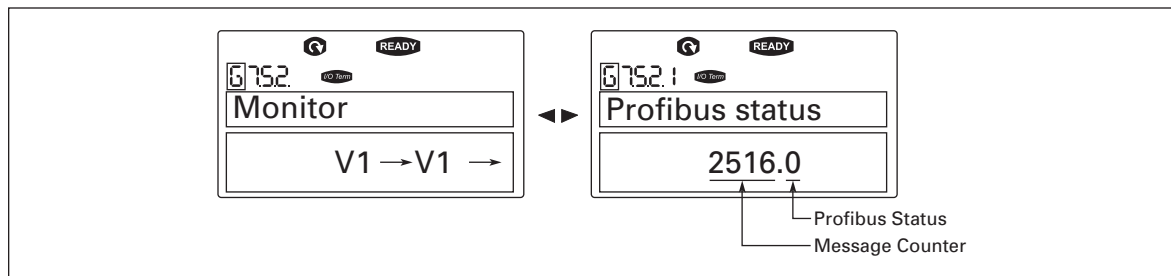

Figure 6-2: Profibus Status

Table 6-2: Profibus Status Indications

	Profibus Status
0	Waiting parameter from Master
1	Waiting configuration from Master
2	Communication established

March 2004

Start-Up Test

Adjustable Frequency Drive Application

Choose Fieldbus (Bus/Comm) as the active control place (see 9000X user's manual).

Master Software

1. Set Control Word value to 0hex.
2. Set Control Word value to 47Fhex.
3. Drive status is RUN.
4. Set Reference value to 5000 (=50.00%).
5. The Actual value is 5000 and the drive output frequency is 25.00 Hz.
6. Set Control Word value to 477hex.
7. Drive status is STOP.

If Status Word bit 3 = 1, Status of the drive is FAULT.

March 2004

Chapter 7 — Profibus-9000X Drive Interface

Features of the Profibus-9000X Drive interface:

- Direct control of drive (e.g. Run, Stop, Direction, Speed reference, Fault reset)
- Full access to all drive parameters
- Monitor drive status (e.g. Output frequency, Output current, Fault code)

General

Data transfer between Profibus DP master and slave takes place via the input/output data field. The Master writes to Slave's output data and the Slave answers by sending the contents of its input data to the Master. The contents of the input/output data is defined in the device profile. The device profile for drives is PROFIDRIVE.

The 9000X drive can be controlled by Profibus DP Master using the PPO-types defined in Profidrive (see **Page 7-2**). When fieldbus has been selected as the drive's active control place, the drive's operation can be controlled from the Profibus DP Master. Whether or not the active control place is fieldbus, the drive can be monitored and its parameters set by the Profibus DP Master.

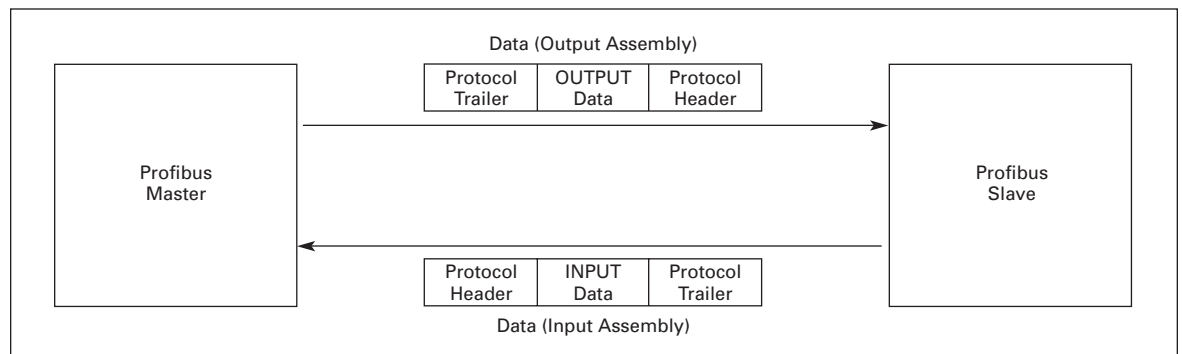

Figure 7-1: Data Transfer Between Profibus Master and Slaves

Operation Mode

The parameter Operation mode (G7.5.1.4, see above) defines how the input/output data is handled on the option board.

PROFIDRIVE

- Data transfer follows the document Profibus Profile for variable speed drives, PROFIDRIVE.

BYPASS

- The information of the Process Data field is transferred to the application interface without handling.
- Parameter setting takes place according to the Profidrive definition.

ECHO

- The OUTPUT data written by the Master is echoed back to the Master in the INPUT field.
- The data is not shown in the drive, but the echoing is carried out on the option board.
- This mode can be used when the function of the bus connection is tested.

PPO Types

PPOs (Parameter/Process Data Object) are the communication objects in PROFIBUS DP.

The PPOs for 9000X drive:

Parameter Field			Process Data Field									
ID	IND	Value	CW	REF	PD1	PD2	PD3	PD4	PD5	PD6	PD7	PD8
			SW	ACT	PD1	PD2	PD3	PD4	PD5	PD6	PD7	PD8

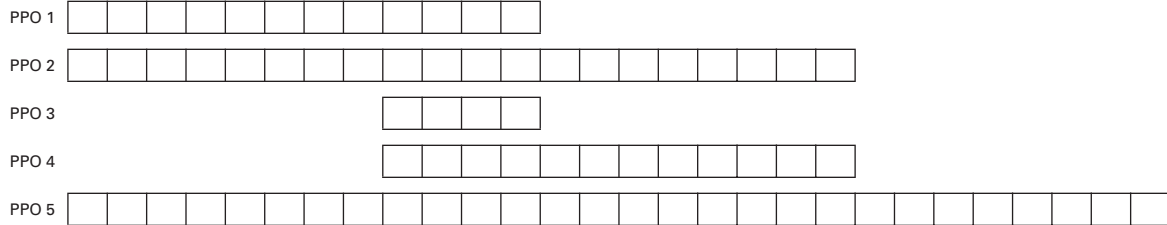

Descriptions:

- Byte
- ID Parameter type and number
- IND Parameter subindex
- VALUE Parameter value
- CW Control Word
- SW Status Word
- REF Reference Value 1
- ACT Actual Value 1
- PD Process Data

March 2004

Process Data

The process data field is used to control the device (e.g. Run, Stop, Reference, Fault Reset) and in reading quick actual values (e.g. Output frequency, Output current, Fault code). The size of the field varies between 2 – 20 bytes. The field is structured as follows:

Process Data Master → Slave (max 20 bytes)

CW		REF		PD1		PD2		PD3		PD4		PD5		PD6		PD7		PD8	

Process Data Slave → Master (max 20 bytes)

SW		ACT		PD1		PD2		PD3		PD4		PD5		PD6		PD7		PD8	

The use of process data depends on the application. In a typical situation the device is started and stopped via the ControlWord (CW) written by the Master and the Rotating speed is set with Reference (REF). Via PD1 – PD8 the device can be given other reference values (e.g. Torque reference).

With the help of the StatusWord (SW) read by the Master, the status of the device can be seen. Actual Value (ACT) and PD1 – PD8 show the other actual values. See **Figure 7-2**.

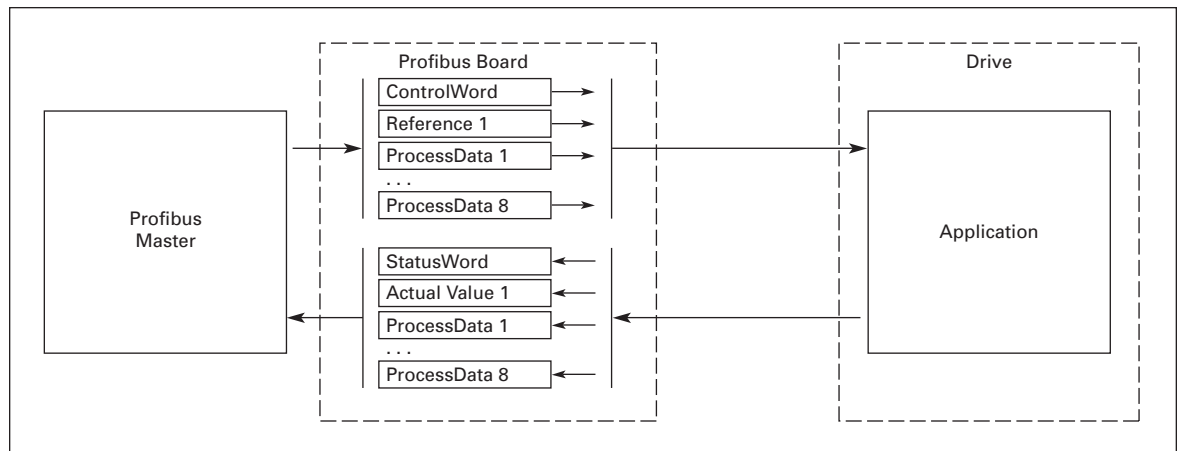

Figure 7-2: Control of the Drive Through Profibus

Control Word

CW		REF		PD1		PD2		PD3		PD4		PD5		PD6		PD7		PD8	

The Control command for the state machine (see **Figure 7-2**). The state machine describes the device status and the possible control sequence of the frequency converter.

The control word is composed of 16 bits that have the following meanings:

Table 7-1: Control Word Bit Descriptions

Bit	Description	
	Value = 0	Value = 1
0	STOP 1 (by ramp)	ON 1
1	STOP 2 (by coast)	ON 2
2	STOP 3 (by ramp)	ON 3
3	RUN DISABLE	ENABLE
4	No Action	START
5	No Action	START
6	No Action	START
7	No Action	FAULT RESET (0 → 1)
8	No Action	No Action
9	No Action	No Action
10	Disable Profibus control	Enable Profibus control
11	Fieldbus DIN1 = OFF	Fieldbus DIN1 = ON
12	Fieldbus DIN2 = OFF	Fieldbus DIN2 = ON
13	Fieldbus DIN3 = OFF	Fieldbus DIN3 = ON
14	Fieldbus DIN4 = OFF	Fieldbus DIN4 = ON
15	Fieldbus DIN5 = OFF	Fieldbus DIN5 = ON

With the help of the control word, START and STOP commands can be given to the device. Also a fault can be acknowledged.

Table 7-2: Commands with Control Word

Command	Control Word	Description
RUN	047Fhex	Start motor if "Fieldbus" is active control source
STOP 1	047Ehex	Stop by Ramp
STOP 2	047Dhex	Stop by Coast
STOP 3	047Bhex	Stop by Ramp
RUN DISABLE	0477hex	Stop by Coast
FAULT RESET (step 1)	bit 7 = 0	Rising edge to bit 7
FAULT RESET (step 2)	bit 7 = 1	

As shown above, there are several stop modes. It depends on the operating situation, which mode is selected.

Note: In the 9000X drive, STOP1 and STOP3 are identical. Also STOP2 and RUN DISABLE are identical.

Commands STOP1 and STOP3 can be used only with either one of the motor control modes (P2.6.1) Frequency control or Speed control selected and the fieldbus selected as the control place.

March 2004

Status Word

SW	ACT	PD1	PD2	PD3	PD4	PD5	PD6	PD7	PD8

Information about the status of the device and messages is indicated in the Status word.

The Status word is composed of 16 bits that have the following meanings:

Table 7-3: Status Word Bit Descriptions

Bit	Description	
	Value = 0	Value = 1
0	Not Ready (initial)	READY
1	Not Ready	READY
2	DISABLE	ENABLE
3	NO FAULT	FAULT ACTIVE
4	STOP 2	NO STOP 2
5	STOP 3	NO STOP 3
6	START ENABLE	START DISABLE
7	No Warning	Warning
8	Reference ≠ Actual value	Reference = Actual value
9	Fieldbus control OFF	Fieldbus control ON
10	Not used	Not used
11	Not used	Not used
12	Drive stopped	Running
13	Drive not ready	Drive ready
14	Not used	Not used
15	Not used	Not used

State Machine

The state machine describes the device status and the possible control sequence of the drive. The state transitions can be generated by using the "Control word". The "Status word" indicates the current status of the state machine. The modes INIT, STOP, RUN and FAULT (see **Figure 7-2**) correspond to the actual mode of the drive.

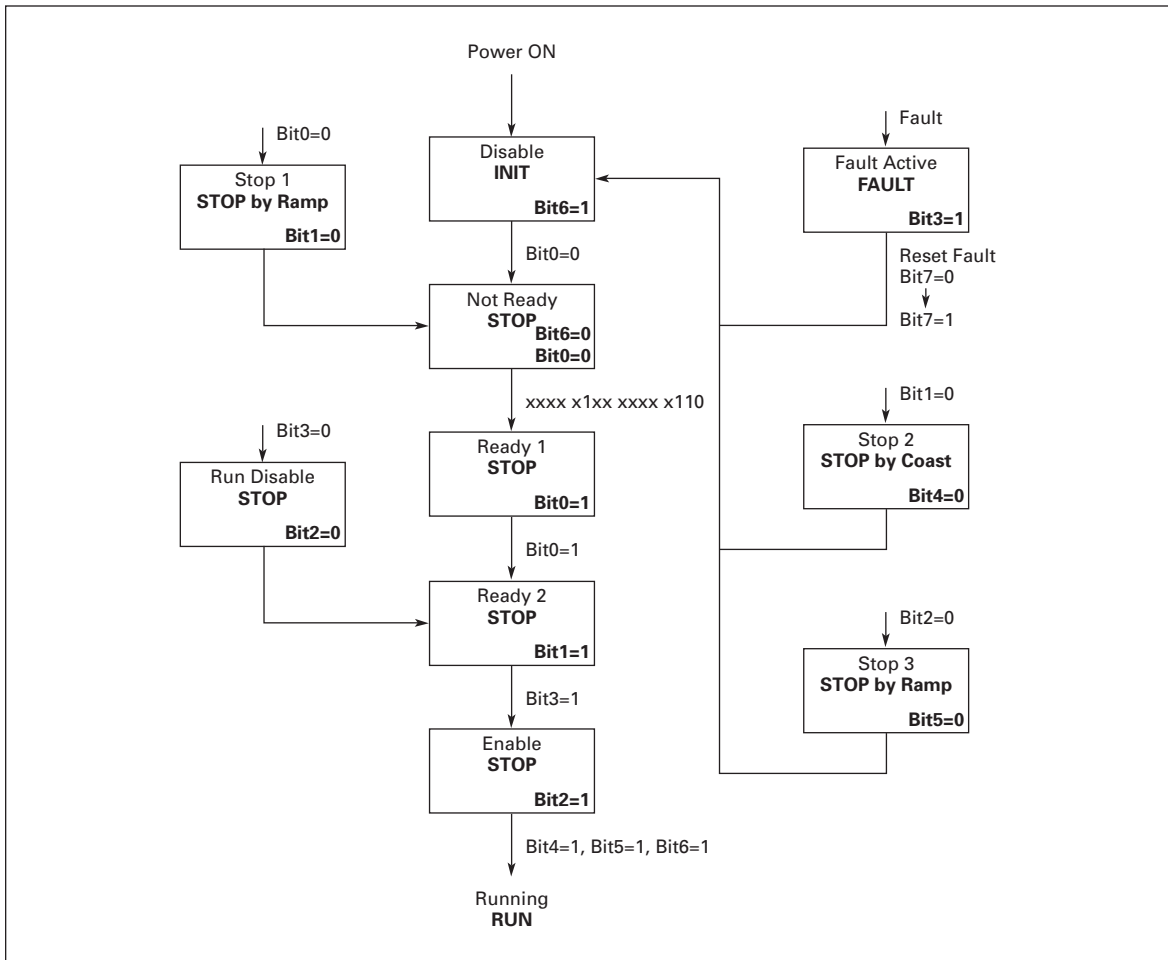

Figure 7-3: State Machine

Reference 1

CW	REF	PD1	PD2	PD3	PD4	PD5	PD6	PD7	PD8

This is the reference 1 to the drive. Used normally as Speed reference. The allowed scaling is -10000 – 10000. In the application, the value is scaled in percentage of the frequency area between set minimum and maximum frequency.

- 10000 = 100.00% (Direction reverse)
- 0 = 0.00% (Direction forward)
- 10000 = 100.00% (Direction forward)

March 2004

Actual Value 1

SW		ACT		PD1		PD2		PD3		PD4		PD5		PD6		PD7		PD8	

This is the actual value from the drive. Used normally as Speed reference, with the value between -10000 – 10000. In the application, the value is scaled in percentage of frequency area between set minimum and maximum frequency.

- 10000 = 100.00% (Direction reverse)
- 0 = 0.00% (Direction forward)
- 10000 = 100.00% (Direction forward)

PD1 — PD8

ProcessData Master → Slave

CW		REF		PD1		PD2		PD3		PD4		PD5		PD6		PD7		PD8	

The Master can write max. 8 additional setting values to the device with the help of the Process Data. How these setting values are used is totally dependent on the application in use.

ProcessData Slave → Master

SW		ACT		PD1		PD2		PD3		PD4		PD5		PD6		PD7		PD8	

The master can read the drive’s actual values using the process data variables. Depending on the used application, the contents are either standard or can be selected with a parameter.

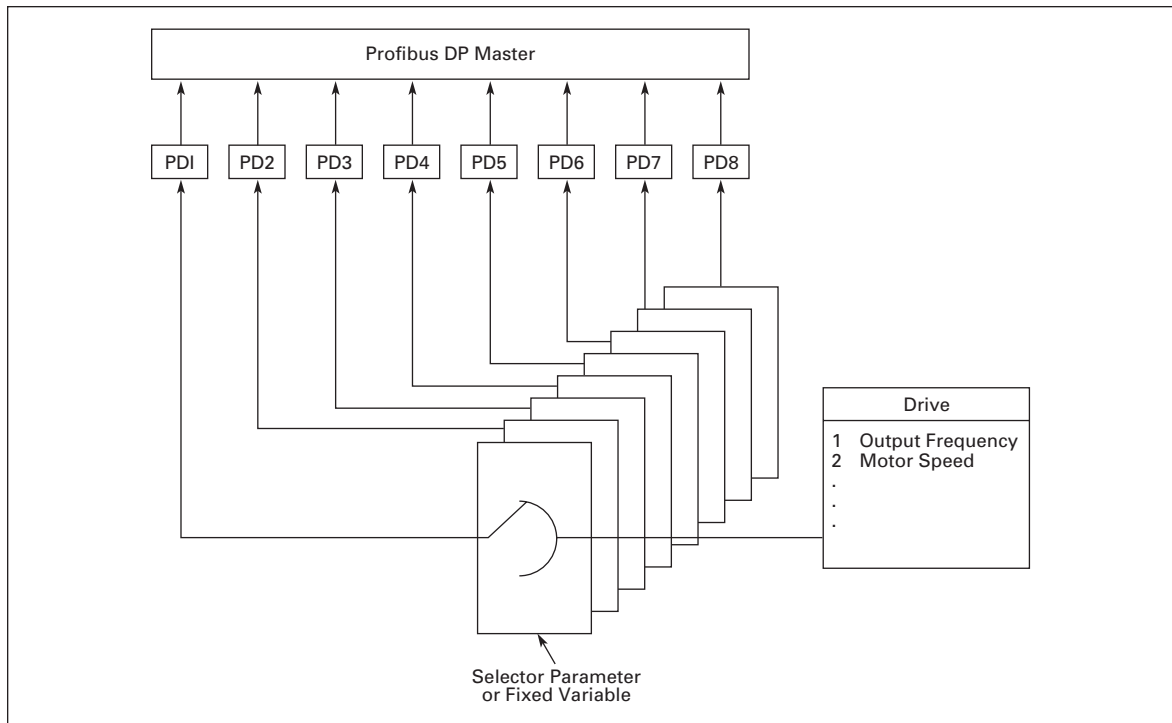

Figure 7-4: Control of Process Data
(See Appendix A)

Parameter Data

The drive’s variables and fault codes as well as the parameters can be read and written using PPO types 1, 2 and 5. The reading and writing can be done via the parameter field of the profibus message frame. The device parameters can be read and written and the actual values read with the help of the parameter field. The size of the parameter field is 8 bytes and it is divided into three parts, ID, Index and Value.

ID	IND	VALUE

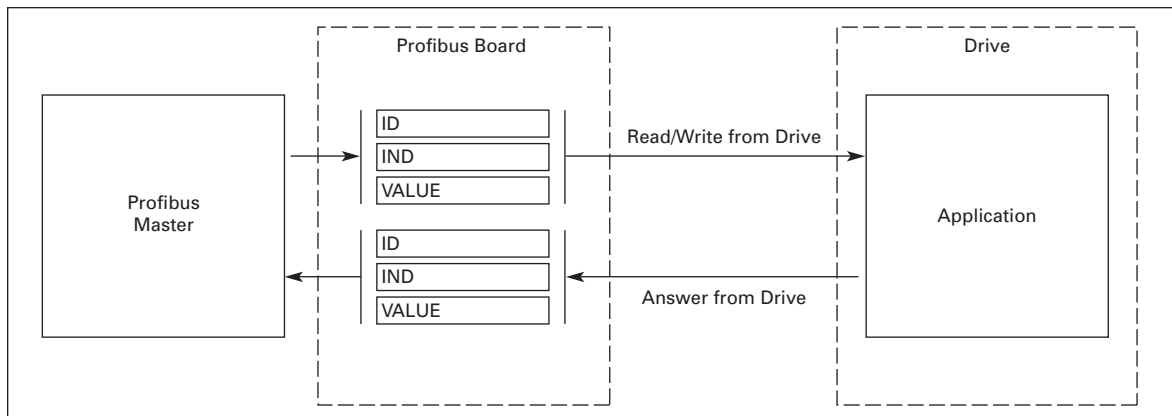

Figure 7-5: Transfer of Parameter Data

March 2004

The parameter addresses are determined in the application. Every parameter and actual value has been given an ID number in the application. The ID numbering of the parameter as well as the parameter ranges and steps can be found in the application manual in question. The parameter value shall be given without decimals. The ID numbers of each parameter/ actual value are found in the application manual. The ID numbers are grouped as follows:

Table 7-4: Grouping of ID Numbers

Parameter ID	Group	Description
0	Not used	
1 – 98	Actual Values	
99	Active Fault Code	
100	Not Used	
101 – 899	Parameter	
900 – 999	Reserved	Reserved for Profibus internal usage
1000	Not Used	
1001 – 1999	Parameter	

Parameter Field

Task and Parameter ID

ID	IND	VALUE

ID Byte 1								ID Byte 2							
15	14	13	12	11	10	9	8	7	6	5	4	3	2	1	0
Request/Response Type				SM	Parameter Number (= Drive ID number)										

SM: Spontaneous bit (not used)

Table 7-5: Request/Response Types

Request	Function	Response	Function
0	No request	0	No request
1	Read parameter value (word)	1	Parameter value ready (word)
2	Write parameter value (word)	7	Request rejected (+fault code)

Table 7-6: Fault Numbers (If Response = 7)

Fault Number	Description
0	Illegal Parameter
1	Parameter is read only (e.g. actual values)
2	Parameter value is out of limits
17	Request temporarily rejected (e.g. can be changed only for STOP state)
18	Other fault
101	Unknown request type

Index

ID	IND	VALUE

Not in use

Data Value

ID	IND	VALUE

Data word 1 (HIGH)		Data word 2 (LOW)	
Byte 0	Byte 1	Byte 2	Byte 3

In writing mode the data to be written is placed in the field "Data word 2". In reading mode the answer is in the field "Data word 2". "Data word 1" is normally zero.

Example Messages

Example1, (PPO1 mode):

Read parameter number 102 (ID=102).
Start drive and set speed reference 50.00%.

Command Master → Slave:

ID	1066 hex	1 = Read parameter value 066 = Parameter 102 (= e.g. maximum frequency)
IND	0000 hex	0000 = No meaning
VALUE	0000 0000 hex	0000 0000 = No meaning
CW	047F hex	04 7F = Start command (see Pages 7-3 and 7-6)
REF	1388 hex	Speed ref. 50.00% (= 25.00 Hz if parameter min. frequency 0 Hz and max. frequency 50 Hz)

PPO1 frame (Parameter Field as Bold text):

10	66	00	00	00	00	00	00	04	7F	13	88
-----------	-----------	-----------	-----------	-----------	-----------	-----------	-----------	----	----	----	----

Answer Slave → Master:

ID	1066 hex	1 = Parameter value ready 066 = Parameter 102 (= Maximum frequency)
IND	0000 hex	0000 = No meaning
VALUE	0000 1388 hex	0000 1388 = Parameter value = 1388hex (50.00 Hz)
SW	0000 hex	0000 = drive status (see Pages 7-5 and 7-6)
ACT	0000 hex	Current speed 0.00% (= 0.00 Hz if parameter min. frequency 0 Hz and max. frequency 50 Hz)

PPO1 frame (Parameter Field as Bold text):

10	66	00	00	00	00	13	88	00	00	00	00
-----------	-----------	-----------	-----------	-----------	-----------	-----------	-----------	----	----	----	----

March 2004

Example 2, (PPO1 Mode):

Write to parameter number 700 (par. 2.7.1) value 2.
Keep Run mode on and Send speed reference 75.00%.

Command Master → Slave:

ID	22BC hex	2 = Write parameter value 2BC = Parameter 700
IND	0000 hex	0000 = No meaning
VALUE	0000 0002 hex	000 0002 = Parameter value
CW	047F hex	04 7F = Start command (see Pages 7-3 and 7-6)
REF	1D4C hex	Speed ref. 75.00% (= 37.50 Hz if parameter min. frequency 0 Hz and max. frequency 50 Hz)

PPO1 frame (Parameter Field as Bold text):

22	BC	00	00	00	00	00	02	04	7F	1D	4C
----	-----------	----	----	----	----	----	----	----	----	----	----

Answer Slave → Master:

ID	12BC hex	1 = Parameter value ready 2BC = Parameter 700 (= Response to reference fault)
IND	0000 hex	0000 = No meaning
VALUE	0000 0032 hex	000 0000 = No meaning
SW	0337 hex	0337 = drive status (see Pages 7-5 and 7-6)
ACT	09C4 hex	Current speed 25.00% (= 12.50 Hz if parameter min. frequency 0 Hz and max. frequency 50 Hz)

PPO1 frame (Parameter Field as Bold text):

12	BD	00	00	00	00	00	00	03	37	09	C4
----	-----------	----	----	----	----	----	----	----	----	----	----

March 2004

Chapter 8 — Fault Tracking

The table below presents the faults related to the Profibus option board. For more information, see the 9000X user’s manual. The **Profibus option board status LEDs** have been described in more detail on **Page 4-6**.

Table 8-1: Profibus Option Board Faults

Fault Code	Fault	Possible Cause	Correcting Measures
37	Device change	Option board changed.	Reset.
38	Device added	Option board added.	Reset.
39	Device removed	Option board removed.	Reset.
40	Device unknown	Unknown option board.	
53	Fieldbus fault	The data connection between the Profibus Master and the Profibus option board is broken.	Check the installation. If installation is correct contact your Cutler-Hammer representative.
54	Slot fault	Defective option board or slot.	Check the board and slot. Contact your Cutler-Hammer representative.

You can define with parameters how the drive will react to certain faults:

Table 8-2: Drive Responses to Faults

Code	Parameter	Min	Max	Unit	Step	Default	ID	Note
P2.7.22	Response to fieldbus fault	0	3		1	0	733	0 = No response 1 = Warning 2 = Fault, stop acc. to 2.4.7 3 = Fault, stop by coasting
P2.7.23	Response to slot fault	0	3		1	0	734	0 = No response 1 = Warning 2 = Fault, stop acc. to 2.4.7 3 = Fault, stop by coasting

March 2004

Chapter 9 — Type Files

GSD-file (“Profibus Support Disk” files: vac29500.GSD, vac29500.GSE)

#Profibus_DP		Sync_Mode_supp	= 1
GSD_Revision	= 1	Auto_Baud_supp	= 1
Vendor_Name	= “Control”	Set_Slave_Add_supp	= 0
Model_Name	= “NX”	Min_Slave_Intervall	= 20
Revision	= “1.0”	Modular_Station	= 1
Ident_Number	= 0x9500	Max_Module	= 5
Protocol_Ident	= 0	Max_Input_Len	= 28
Station_Type	= 0	Max_Output_Len	= 28
FMS_supp	= 0	Max_Data_Len	= 56
Hardware_Release	= “HW1.0”	Modul_Offset	= 0
Software_Release	= “SW1.0”	Slave_Family	= 1
9.6_supp	= 1	Fail_Safe	= 1
19.2_supp	= 1	Max_Diag_Data_Len	= 6
93.75_supp	= 1	Module	= “PPO 1” 0xF3, 0xF1
187.5_supp	= 1	EndModule;	
500_supp	= 1	Module	= “PPO 2” 0xF3, 0xF5
1.5M_supp	= 1	EndModule;	
3M_supp	= 1	Module	= “PPO 3” 0xF1
6M_supp	= 1	EndModule;	
12M_supp	= 1	Module	= “PPO 4” 0xF5
MaxTsd_9.6	= 60	EndModule;	
MaxTsd_19.2	= 60	Module	= “PPO 5” 0xF3, 0xF9
MaxTsd_93.75	= 60	EndModule;	
MaxTsd_187.5	= 60	Module	= “_____special_____” 0x00
MaxTsd_500	= 100	EndModule	
MaxTsd_1.5M	= 150	Module	= “PPO 2” 0xF3, 0xF1, 0xF1, 0xF1
MaxTsd_3M	= 250	EndModule	
MaxTsd_6M	= 450	Module	= “PPO 4” 0xF1, 0xF1, 0xF1
MaxTsd_12M	= 800	EndModule	
Redundancy	= 0	Module	= “PPO 5” 0xF3, 0xF1, 0xF1, 0xF1, 0xF1, 0xF1
Repeater_Ctrl_Sig	= 0	EndModule	
24V_Pins	= 0	Module	
Implementation_Type	= “SPC3”	EndModule	
Freeze_Mode_supp	= 1	EndModule	

March 2004

Appendix A — Process Data

Process Data OUT (Slave → Master)

The fieldbus master can read the drive's actual values using process data variables. Basic, Standard, Local/Remote, Multi-Step, PID control and Pump and Fan Control applications use process data as follows:

Table A-1: Process Data OUT for All Applications

Data	Value	Unit	Scale
Process data OUT 1	Output Frequency	Hz	0.01 Hz
Process data OUT 2	Motor Speed	rpm	1 rpm
Process data OUT 3	Motor Current	A	0.1 A
Process data OUT 4	Motor Torque	%	0.1 %
Process data OUT 5	Motor Power	%	0.1 %
Process data OUT 6	Motor Voltage	V	0.1 V
Process data OUT 7	DC link voltage	V	1 V
Process data OUT 8	Active Fault Code	—	—

The Multipurpose application has a selector parameter for every Process Data. The monitoring values and drive parameters can be selected using the ID number (see 9000X Application Manual, Tables for monitoring values and parameters). Default selections are as in the table above.

Process Data IN (Master → Slave)

ControlWord, Reference and Process Data are used with All-in-One applications as follows:

Table A-2: Process Data IN for Basic, Standard, Local/Remote, Multi-Step Applications

Data	Value	Unit	Scale
Reference	Speed Reference	%	0.01%
ControlWord	Start/Stop Command Fault reset Command	—	—
PD1 – PD8	Not used	—	—

Table A-3: Process Data IN for Multipurpose Control Application

Data	Value	Unit	Scale
Reference	Speed Reference	%	0.01%
ControlWord	Start/Stop Command Fault reset Command	—	—
Process Data IN1	Torque Reference	%	0.1%
Process Data IN2	Free Analogue INPUT	%	0.01%
Process Data IN3	Adjust Input	%	0.01%
PD3 – PD8	Not Used	—	—

Table A-4: Process Data IN for PID Control and Pump and Fan Control Applications

Data	Value	Unit	Scale
Reference	Speed Reference	%	0.01%
ControlWord	Start/Stop Command Fault reset Command	—	—
Process Data IN1	Reference for PID controller	%	0.01%
Process Data IN2	Actual Value 1 to PID controller	%	0.01%
Process Data IN3	Actual Value 2 to PID controller	%	0.01%
PD4 – PD8	Not Used	—	—

Company Information

Eaton Electrical Inc. is a global leader in electrical control, power distribution, and industrial automation products and services. Through advanced product development, world-class manufacturing methods, and global engineering services and support, Eaton Electrical® provides customer-driven solutions under brand names such as Cutler-Hammer®, Durant®, Heinemann®, Holec® and MEM®, which globally serve the changing needs of the industrial, utility, light commercial, residential, and OEM markets. For more information, visit www.eatonelectrical.com.

Eaton Corporation is a global diversified industrial manufacturer with 2002 sales of \$7.2 billion that is a leader in fluid power systems; electrical power quality, distribution and control; automotive engine air management and fuel economy; and intelligent drivetrain systems for fuel economy and safety in trucks. Eaton has 51,000 employees and sells products in more than 50 countries. For more information, visit www.eaton.com.

Eaton Electrical
1000 Cherrington Parkway
Moon Township, PA 15108-4312
USA
tel: 1-800-525-2000
www.eatonelectrical.com

EAT•N

Cutler-Hammer

© 2004 Eaton Corporation
All Rights Reserved
Printed in USA
Publication No. MN04003006E/CPG
March 2004