



# Cutler-Hammer

## 9000X Series Drives Option Board

User Manual

October 2005  
Supersedes July 2005





October 2005

**Important Notice – Please Read**

The product discussed in this literature is subject to terms and conditions outlined in Eaton Electrical Inc. selling policies. The sole source governing the rights and remedies of any purchaser of this equipment is the relevant Eaton Electrical Inc. selling policy.

NO WARRANTIES, EXPRESS OR IMPLIED, INCLUDING WARRANTIES OF FITNESS FOR A PARTICULAR PURPOSE OR MERCHANTABILITY, OR WARRANTIES ARISING FROM COURSE OF DEALING OR USAGE OF TRADE, ARE MADE REGARDING THE INFORMATION, RECOMMENDATIONS AND DESCRIPTIONS CONTAINED HEREIN. In no event will Eaton Electrical Inc. be responsible to the purchaser or user in contract, in tort (including negligence), strict liability or otherwise for any special, indirect, incidental or consequential damage or loss whatsoever, including but not limited to damage or loss of use of equipment, plant or power system, cost of capital, loss of power, additional expenses in the use of existing power facilities, or claims against the purchaser or user by its customers resulting from the use of the information, recommendations and descriptions contained herein.

The information contained in this manual is subject to change without notice.

Cover Photo: 9000X Drives

## Table of Contents

<b>CHAPTER 1 — GENERAL INFORMATION</b> .....	1-1
Board Slots on the Control Board .....	1-1
Option Board Types .....	1-2
Technical Data .....	1-3
Hardware Protections .....	1-6
<b>CHAPTER 2 — OPTION BOARD INSTALLATION</b> .....	2-1
Control Wiring .....	2-2
EMC Directive .....	2-2
Control Cable Grounding .....	2-2
<b>CHAPTER 3 — OPTA OPTION BOARDS</b> .....	3-1
Option Board A1 .....	3-1
Option Board A2 .....	3-5
Option Board A3 .....	3-6
Option Board A4 (SPX9000 Only) .....	3-7
Option Board A5 (SPX9000 Only) .....	3-10
Option Board A7 (SPX9000 Only) .....	3-14
Option Board A8 .....	3-19
Option Board A9 .....	3-23
Option Board AE .....	3-27
<b>CHAPTER 4 — OPTB OPTION BOARDS</b> .....	4-1
Option Board B1 .....	4-1
Option Board B2 .....	4-3
Option Board B4 .....	4-5
Option Board B5 .....	4-7
Option Board B8 .....	4-8
Option Board B9 .....	4-10
Option Board BB .....	4-11
<b>CHAPTER 5 — OPTD ADAPTER BOARDS</b> .....	5-1
Option Board D1 .....	5-1
Option Board D2 .....	5-3
Option Board D3 .....	5-5
<b>CHAPTER 6 — OPTION BOARDS — DETAIL SUMMARY</b> .....	6-1

## List of Figures

Figure 1-1: Board Slots on the Control Board .....	1-1
Figure 1-2: Maximum Loads on +24V/EXT+24V Output .....	1-4
Figure 1-3: CMA Connected to GND with the Onboard Jumper .....	1-5
Figure 1-4: Positive Logic .....	1-6
Figure 1-5: Negative Logic .....	1-6
Figure 1-6: Board Slot Guide to Prevent Plugging In of Incorrect Boards .....	1-7
Figure 1-7: Example of Function/Parameter Address Code .....	1-7
Figure 1-8: Example of Function/Parameter Programming .....	1-8
Figure 1-9: Board Parameter Value Editing Example .....	1-9
Figure 2-1: Option Board Installation .....	2-1
Figure 2-2: Checking Option Board Installation .....	2-1
Figure 2-3: Control Cable Grounding .....	2-2
Figure 3-1: Option Board A1 Wiring Diagram .....	3-2
Figure 3-2: Option Board A1 Jumper Locations .....	3-2
Figure 3-3: Option Board A1 Jumper Settings .....	3-3
Figure 3-4: Option Board A2 Wiring Diagram .....	3-5
Figure 3-5: Option Board A2 Terminal Locations .....	3-6
Figure 3-6: Option Board A3 Wiring Diagram .....	3-6

October 2005

Figure 3-7: Option Board A3 Terminal Locations .....	3-7
Figure 3-8: Jumper Positions for Option Board A4 .....	3-8
Figure 3-9: Option Board A4 Terminal and Jumper Locations .....	3-9
Figure 3-10: Option Board A4 Encoder Connection Using Differential Inputs ..	3-9
Figure 3-11: Option Board A4 Encoder .....	3-9
Figure 3-12: Jumper Positions for Option Board A5 .....	3-11
Figure 3-13: Option Board A5 Terminal and Jumper Locations .....	3-11
Figure 3-14: HTL Type Encoder Connection (Open Source) Using Single-Ended Inputs .....	3-12
Figure 3-15: HTL Type Encoder Connection (Open Collector) Using Single-Ended Inputs .....	3-12
Figure 3-16: HTL Type Encoder Connection Using Differential Inputs .....	3-13
Figure 3-17: Option Board A5 Encoder .....	3-13
Figure 3-18: Option Board A7 Terminal and Jumper Locations .....	3-14
Figure 3-19: Jumper Positions for Option Board A7 .....	3-16
Figure 3-20: Connection of Encoder and Three OPTA7 Boards .....	3-17
Figure 3-21: Connection of Two Encoders to OPTA7 Board .....	3-18
Figure 3-22: Option Board A8 Wiring Diagram .....	3-19
Figure 3-23: Option Board A8 Terminal Locations .....	3-21
Figure 3-24: Option Board A8 Jumper Locations and Settings .....	3-22
Figure 3-25: Option Board A9 Wiring Diagram .....	3-23
Figure 3-26: Option Board A9 Terminal Locations .....	3-25
Figure 3-27: Option Board A9 Jumper Locations and Settings .....	3-26
Figure 3-28: Option Board AE Terminal Locations .....	3-27
Figure 3-29: Jumper Positions for Option Board AE .....	3-29
Figure 3-30: HTL Type Encoder Connection (Open Source) Using Single-Ended Inputs .....	3-29
Figure 3-31: HTL Type Encoder Connection (Open Collector) Using Single-Ended Inputs .....	3-30
Figure 3-32: HTL Type Encoder Connection Using Differential Inputs .....	3-30
Figure 4-1: Option Board B1 Terminal Locations .....	4-2
Figure 4-2: Jumper Positions for OPTB1 .....	4-3
Figure 4-3: Option Board B2 Wiring Diagram .....	4-4
Figure 4-4: Option Board B2 Terminal Locations .....	4-5
Figure 4-5: Option Board B4 Wiring Diagram .....	4-5
Figure 4-6: Option Board B4 Terminal Locations .....	4-6
Figure 4-7: Option Board B5 Wiring Diagram .....	4-7
Figure 4-8: Option Board B5 Terminal Locations .....	4-8
Figure 4-9: Option Board B8 PT-100 Connections .....	4-9
Figure 4-10: Option Board B8 Jumper Selections .....	4-9
Figure 4-11: Option Board B8 Terminal Locations .....	4-9
Figure 4-12: Option Board B9 Wiring Diagram .....	4-10
Figure 4-13: Option Board B9 Terminal Locations .....	4-11
Figure 4-14: Option Board BB Jumper Selections .....	4-13
Figure 4-15: Option Board BB Terminal Locations .....	4-13
Figure 5-1: Option Board D1 Terminal Locations .....	5-2
Figure 5-2: Basic Connection Between Drives with D1 Option Board .....	5-2
Figure 5-3: Option Board D2 Terminal Locations .....	5-3
Figure 5-4: Option Board D2 Jumper Selections .....	5-4
Figure 5-5: Connection Example for Drives with D2 Option Board .....	5-5
Figure 5-6: Option Board D3 RS-232 Sub-D Connector and LED Location .....	5-6
Figure 5-7: Option Board D3 Jumper Selections .....	5-6

## List of Tables

Table 1-1: Technical Data . . . . .	1-3
Table 2-1: Tightening Torques for Control Terminals . . . . .	2-2
Table 2-2: Control Cable Type Required to Meet the EU EMC Standards . . . . .	2-2
Table 3-1: OPTA_ Board Features . . . . .	3-1
Table 3-2: Option Board A1 Terminal Descriptions . . . . .	3-4
Table 3-3: Option Board A1 Parameters . . . . .	3-5
Table 3-4: Option Board A2 Terminal Descriptions . . . . .	3-6
Table 3-5: Option Board A3 Terminal Descriptions . . . . .	3-7
Table 3-6: Option Board A4 Terminal Descriptions . . . . .	3-8
Table 3-7: Option Board A4 Technical Data . . . . .	3-8
Table 3-8: Option Board A4 Parameters . . . . .	3-10
Table 3-9: Option Board A5 Terminal Descriptions . . . . .	3-10
Table 3-10: Option Board A5 Technical Data . . . . .	3-11
Table 3-11: Option Board A5 Parameters . . . . .	3-13
Table 3-12: Option Board A7 Terminal Descriptions . . . . .	3-15
Table 3-13: Option Board A7 Technical Data . . . . .	3-15
Table 3-14: Option Board A8 Terminal Descriptions . . . . .	3-20
Table 3-15: Option Board A8 Parameters . . . . .	3-21
Table 3-16: Option Board A9 Terminal Descriptions . . . . .	3-24
Table 3-17: Option Board A9 Parameters . . . . .	3-25
Table 3-18: Option Board AE Terminal Descriptions . . . . .	3-28
Table 3-19: Option Board AE Technical Data . . . . .	3-28
Table 3-20: Option Board AE Parameters . . . . .	3-31
Table 4-1: OPTB_ Board Features . . . . .	4-1
Table 4-2: OPTB1 I/O Terminals . . . . .	4-2
Table 4-3: Option Board B2 Terminal Descriptions . . . . .	4-4
Table 4-4: Option Board B4 I/O Terminals . . . . .	4-6
Table 4-5: Option Board B5 I/O Terminals . . . . .	4-7
Table 4-6: Option Board B8 I/O Terminals . . . . .	4-8
Table 4-7: Option Board B9 I/O Terminals . . . . .	4-10
Table 4-8: Encoder Properties . . . . .	4-11
Table 4-9: I/O Terminals on Option Board BB, Terminal Block X6 . . . . .	4-12
Table 4-10: I/O Terminals on Option Board BB, Terminal Block X7 . . . . .	4-12
Table 4-11: Option Board BB Parameters . . . . .	4-13
Table 4-12: Option Board BB Monitored Values . . . . .	4-14
Table 4-13: Option Board BB Information Pages . . . . .	4-14
Table 4-14: Option Board BB LED Status Indicators . . . . .	4-14
Table 5-1: OPTD_ Board Features . . . . .	5-1
Table 5-2: Option Board D1 I/O Terminals . . . . .	5-1
Table 5-3: Option Board D1 Device Count vs. Speed . . . . .	5-2
Table 5-4: Option Board D2 I/O Terminals . . . . .	5-3
Table 5-5: Option Board D2 Device Count vs. Speed . . . . .	5-4
Table 5-6: Option Board D3 RS-232 Sub-D Connector Wiring . . . . .	5-5
Table 5-7: Option Board D3 Status LEDs . . . . .	5-6
Table 6-1: Option Board Summary: 1 of 3 . . . . .	6-1
Table 6-2: Option Board Summary: 2 of 3 . . . . .	6-2
Table 6-3: Option Board Summary: 3 of 3 . . . . .	6-3

October 2005

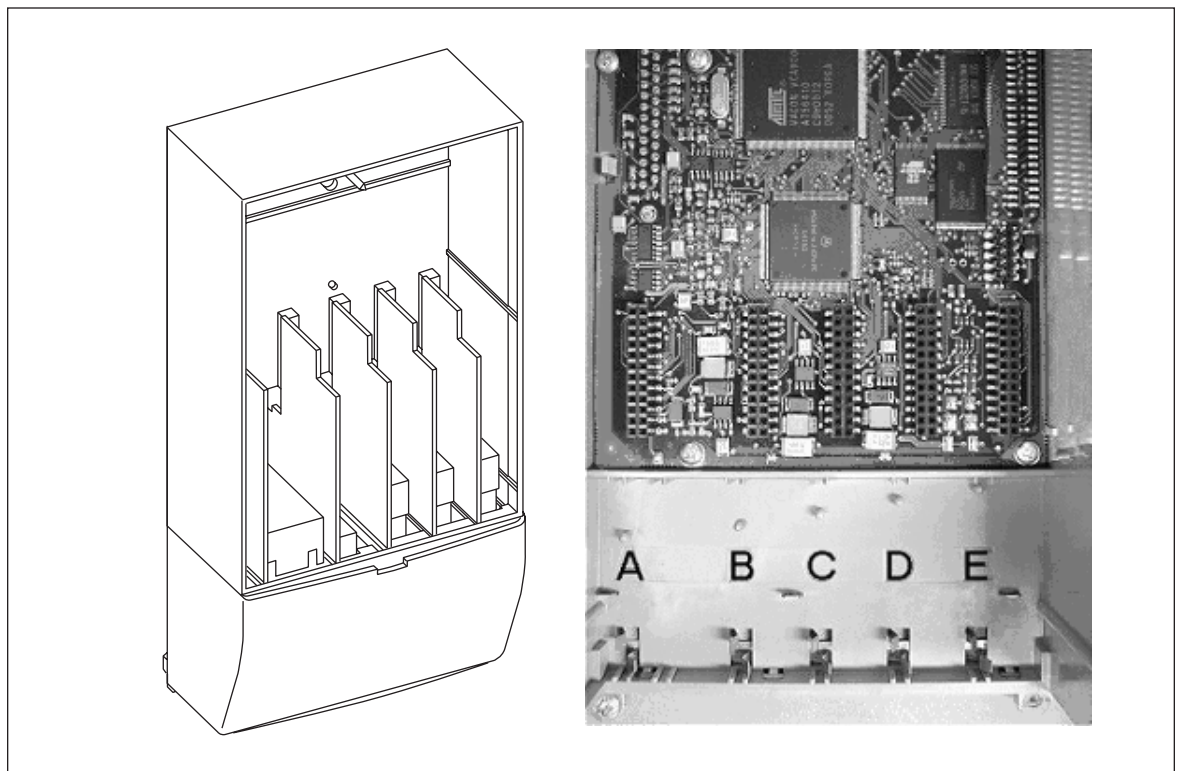
## Chapter 1 — General Information

The Cutler-Hammer® 9000X Series Drives from Eaton's electrical business embody a wide selection of *expander and adapter* boards to increase the number and type of control inputs and outputs (I/O) and communication interfaces to provide the versatility required for today's demanding applications.

The input and output capability is designed with modularity in mind, comprised of option boards, each having its own input and output configuration. The control unit is designed to accept a total of five boards. The boards provide standard analog and digital inputs and outputs, fieldbus capability, and application specific hardware.

The basic, expander and adapter boards are installed in *board slots*, which are part of the control board. The I/O boards are usually interchangeable between different members of the 9000X Series of drives. However, these types of control boards differ from each other to some extent, which may restrict their use.

### Board Slots on the Control Board



**Figure 1-1: Board Slots on the Control Board**

The control board is located inside the *control unit* of the 9000X Series Drive. There are five board slots, labeled A to E, on the control board: The usability of different option boards in the various slots depends on the type of board. For more information see "Option Board Types" on **Page 1-2** and the option board descriptions on **Pages 3-1 to 5-6**.

When the 9000X Series Drive is assembled at the factory, two standard basic boards (I/O board and relay board) are installed in slots A and B. The three additional slots, C, D and E, are available for different options, i.e. I/O expander boards, fieldbus boards and adapter boards.

## Option Board Types

The option boards are divided in four groups according to their characteristics: **A, B, C** and **D**.

### **OPTA\_**

- Boards used for basic I/O; normally pre-installed at the factory
- This board type uses slots A, B and C

See **Pages 3-1 to 3-31** for a detailed description of the available boards of this type. Also see **Tables 6-1 to 6-3** on **Pages 6-1 to 6-3**.

### **OPTB\_**

- Option boards used for I/O expansion
- Normally installed in slots B, C, D and E

See **Pages 4-1 to 4-14** for a detailed description of the available boards of this type. Also see **Tables 6-1 to 6-3** on **Pages 6-1 to 6-3**.

### **OPTC\_**

- Fieldbus boards (e.g. Profibus or Modbus)
- These boards are installed in slots D and E

The OPTC\_ boards are not covered in this manual. Refer to the specific manual for the fieldbus board of interest. Contact your Cutler-Hammer distributor for more information.

### **OPTD\_**

- Adapter boards
- Boards with fiber optic adapters, e.g. System Bus Fiber Optic Adapter Board
- These boards are installed in slots D and E

See **Pages 5-1 to 5-6** for a detailed description of the available boards of this type. Also see **Tables 6-1 to 6-3** on **Pages 6-1 to 6-3**.



October 2005

## Technical Data

The data in **Table 1-1** applies to the inputs and outputs of all the basic and expander boards.

**Table 1-1: Technical Data**

Description	Specification
<b>Safety (all boards)</b>	
Standards	Complies with EN 50178, CUL and EN 60204-1
Isolation	Inputs/outputs galvanically isolated; Isolation voltage rating 500V
<b>Input/output type</b>	
Analog inputs (AI), voltage	0 – ±10V, $R_i \geq 200 \text{ k}\Omega$ , single-ended; Resolution 10 bits/0.1%, accuracy ±1% of the full display (-10 – +10V joystick control)
Analog inputs (AI), current	0(4) – 20 mA, $R_i = 250\Omega$ , differential Resolution 10 bits/0.1%, accuracy ±1% of the full display
Digital inputs (DI), DC voltage controlled	24V: "0" ≤10V, "1" ≥18V, $R_i > 5 \text{ k}\Omega$
Digital inputs (DI), AC voltage controlled	Control voltage 42...240V AC, "0" <33V, "1" >35V
Auxiliary voltage (output) (+24V)	24V (±15%), max. 250 mA (total load from all external +24V outputs), max. 150 mA from any one board
Auxiliary voltage (input) (ext. +24V)	24V DC (±10%, max. ripple voltage 100 mV rms), max. 1A In special applications where PLC type functions are included in the control unit the input can be used as an external auxiliary power supply for control boards as well as I/O boards.
Reference voltage (output) (+10Vref)	10V -0%, +2%, max. 10 mA
Analog output (AO), current (mA)	0(4) – 20 mA, $R_L < 500\Omega$ , resolution 10 bits/0.1%, accuracy ≤±2%
Analog output (AO), voltage (V)	0(2) – 10V, $R_L \geq 1 \text{ k}\Omega$ , resolution 10 bits, accuracy ≤±2%
Relay outputs (RO)	Switching capacity: 24V DC/8A 250V AC/8A 125V DC/0.4A Min. switching load: 5V/10 mA Continuous capacity: < 2A rms
Thermistor input (TI)	$R_{\text{trip}} = 4.7 \text{ k}\Omega$ (PTC type)
Encoder control voltage (+5V/+12V/+15V/+24V)	See OPTA4, OPTA5, OPTA7 and OPTBB technical data <b>Pages 3-7 to 3-17 and 4-11 to 4-14.</b>
Encoder connections (inputs, outputs)	See OPTA4, OPTA5, OPTA7 and OPTBB technical data <b>Pages 3-7 to 3-17 and 4-11 to 4-14.</b>
<b>Environment (all boards)</b>	
Ambient operating temperature	14 – 131° F (-10 – 55°C)
Storage temperature	-40 – 140° F (-40 – 60°C)
Humidity	<95%, no condensation allowed
Altitude	Maximum 3300 feet (1000 meters)
Vibration	0.5G at 9 – 200 Hz

### Isolation

The control connections are isolated from the utility potential, and as shipped the I/O ground is connected directly to the frame of the 9000X Series Drive. Digital inputs and relay outputs are isolated from the I/O ground. For digital input arrangements, see "Digital Input Signal Conversion", **Page 1-5**.

### Analog Inputs (mA/V)

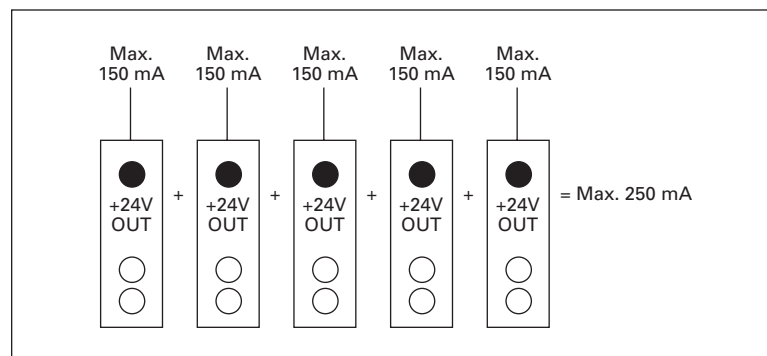
The analog inputs of the I/O boards can be used as either current inputs or voltage inputs (see the detailed description of each board). The signal type is selected with a jumper block on the board. If the voltage input is used, you will need to define the voltage range with another jumper block. The factory default value for the analog signal type is given in the description of the board. For detailed information, see the description of the board of interest.

### Analog Outputs (mA/V)

Most of the expander boards with analog outputs can be configured for a current or voltage output with a jumper. Some boards only provide an analog current output. For detailed information, see the description of the board of interest.

### Control Voltage (+24V/EXT+24V)

The control voltage output +24V/EXT+24V can be used in two ways. Typically, the +24V control voltage is wired to the digital inputs through an external switch. The control voltage can also be used to power up external equipment, such as encoders and auxiliary relays. Note that the *total combined* load on all available +24V/EXT+24V output terminals must not exceed 250 mA. The maximum load on the +24V/EXT+24V output *per board* is 150 mA. See **Figure 1-2**.



**Figure 1-2: Maximum Loads on +24V/EXT+24V Output**

October 2005

The +24V/EXT+24V outputs can be connected to an external +24V power supply to power up the control board and the basic and expander boards. If an external power supply is connected to the EXT+24V output, the control board, basic boards and expander boards remain live even if the utility power is lost to the 9000X Series Drive as long as the external +24V supply is available. This provides partial operation of the control logic (not the power section of the 9000X Series Drive) and some alarms in a major power-loss situation. In addition, the fieldbus links remain powered which enables the fieldbus, e.g. the Profibus Master, to read valuable data from the 9000X Series Drive.

**Note:** The power section of the 9000X Series Drive cannot function if the utility is lost.

Requirements for an external 24V power supply:

- output voltage +24V DC±10%, max. ripple voltage 100 mV rms
- maximum current 1A
- 1A external fuse (no internal short circuit protection is provided on the control board for the external 24V input)

**Note:** Analog outputs and inputs will not work with only external +24V supplied to the control unit.

The +24V/EXT+24V output of an option board is short circuit protected on the board. Should one of the +24V/EXT+24V outputs short, the other boards would remain powered because of the individual board output protection.

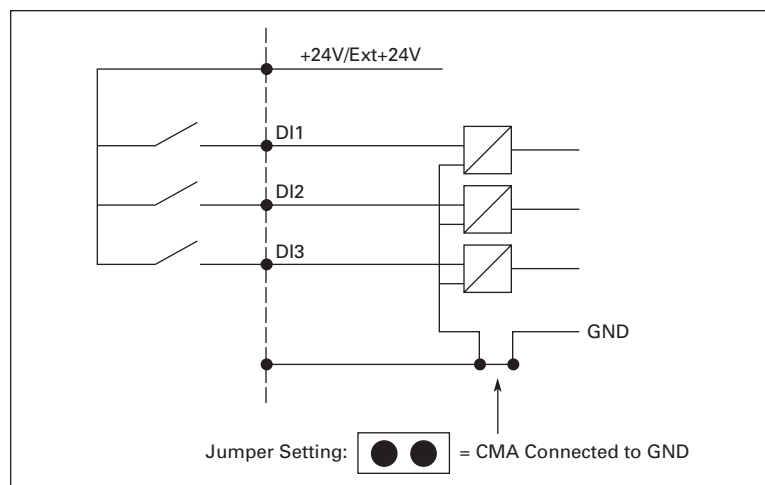
**Digital Input Signal Conversion**

The active signal level depends on which potential the common input CMA (and CMB if available) is connected to. The alternatives are +24V or Ground (0V). See **Figures 1-3, 1-4 and 1-5**.

The 24-volt control voltage and the ground for the digital inputs and the common input (CMA) can be from either the internal +24V supply or an external source.

Three typical input signal connection examples are shown below.

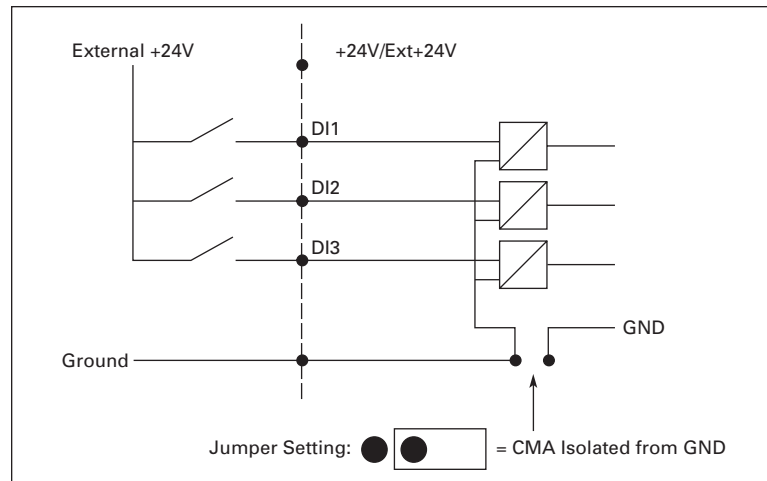
If you use the internal +24V, the following connection can be used:



**Figure 1-3: CMA Connected to GND with the Onboard Jumper**

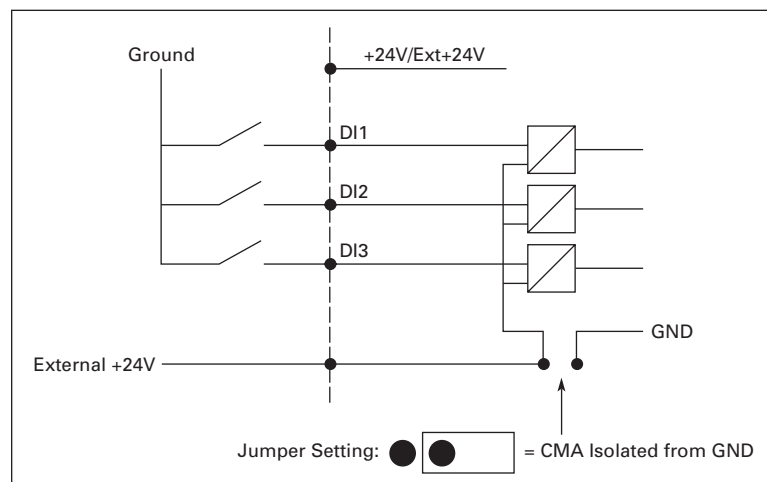
*If CMA is connected to GND with the onboard jumper, the internal +24V is used and the CMA terminal does not need to be wired externally.*

If you use an external +24V supply the following connections can be used:



**Figure 1-4: Positive Logic**

**Positive logic with the external +24V when CMA is isolated from GND with the onboard jumper. The input is active when the switch is closed.**



**Figure 1-5: Negative Logic**

**Negative logic with the external +24V when CMA is isolated from GND with the onboard jumper. The input is active when the switch is closed (0V is the active signal).**

You can also use the positive and negative logic connections with the internal +24V supply. Place the jumper block in the "CMA isolated from GND" position and wire the CMA terminal as shown in **Figures 1-4** and **1-5**.

## Hardware Protections

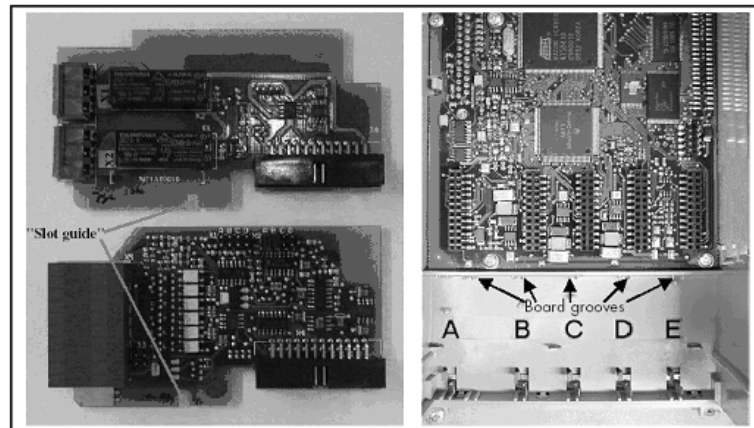
### Terminal Block Keying

In order to avoid incorrect attachment of terminal blocks to boards, some terminal blocks as well as the related terminal connectors on the board are uniquely keyed. For more information, see the description of the individual board.

October 2005

**Board Slot Guides and Allowed Slots**

You cannot plug an option board into any slot. **Tables 6-1 to 6-3 on Pages 6-1 to 6-3** show which slots are allowed for which option boards. For reasons of safety, slots A and B have guides to prevent the use of incorrect boards, as shown in **Figure 1-6**. If an incorrect board is plugged into slots C, D or E, the board will not work, but there is no danger to personnel or for equipment damage.

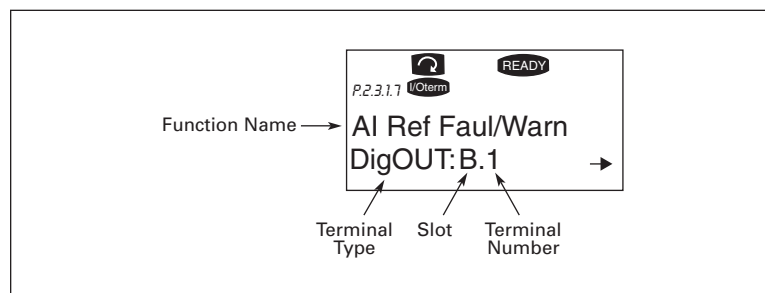


**Figure 1-6: Board Slot Guide to Prevent Plugging In of Incorrect Boards**

**Defining Functions to Inputs and Outputs**

Several of the option boards for the 9000X Series Drive provide flexibility in that a particular I/O feature can be programmed to operate as one of multiple function choices. These function choices appear as parameters in the drive application menu. The operator chooses which function the particular parameter will become.

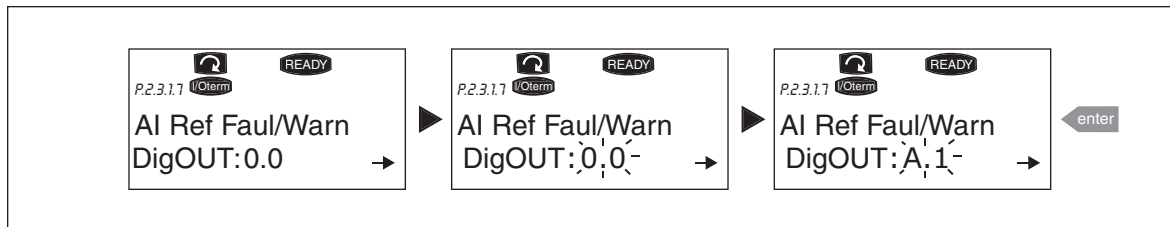
To connect a specific input or output to a certain function (parameter) an *address code* is assigned to the parameter. The code is formed from the control board *slot identification number*, into which the option board is plugged, and the respective *input/output number*. See the example below.



**Figure 1-7: Example of Function/Parameter Address Code**

**Example:** For the application you are using, you want to connect the digital output function *Reference fault/warning* to the digital output DO1 on the basic board OPTA1.

- First find the parameter associated with Reference fault/warning on the keypad. Press the *MENU button right* once to enter the edit mode. On the *value line*, you will see the I/O type on the left (DigIN, DigOUT, AnIN, AnOUT) and on the right, the present input/output the function is connected to (B.3, A.2 etc.), or if not connected, a code 0.#.
- While the value is blinking, hold down the *Browser button up* or *down* to select the desired board slot and input/output number. The program will scroll the board slots starting from **0** and proceeding from **A** to **E** and the I/O numbers from **1** to **10**.
- Once you have set the desired code, press the ENTER button once to confirm the change.



**Figure 1-8: Example of Function/Parameter Programming**

### **CAUTION**

Make certain that only one function is programmed to a given output. If multiple functions are programmed to a single output, function overruns will occur resulting in unintended operation.

**Note:** Inputs, unlike outputs, cannot be changed in the RUN state.

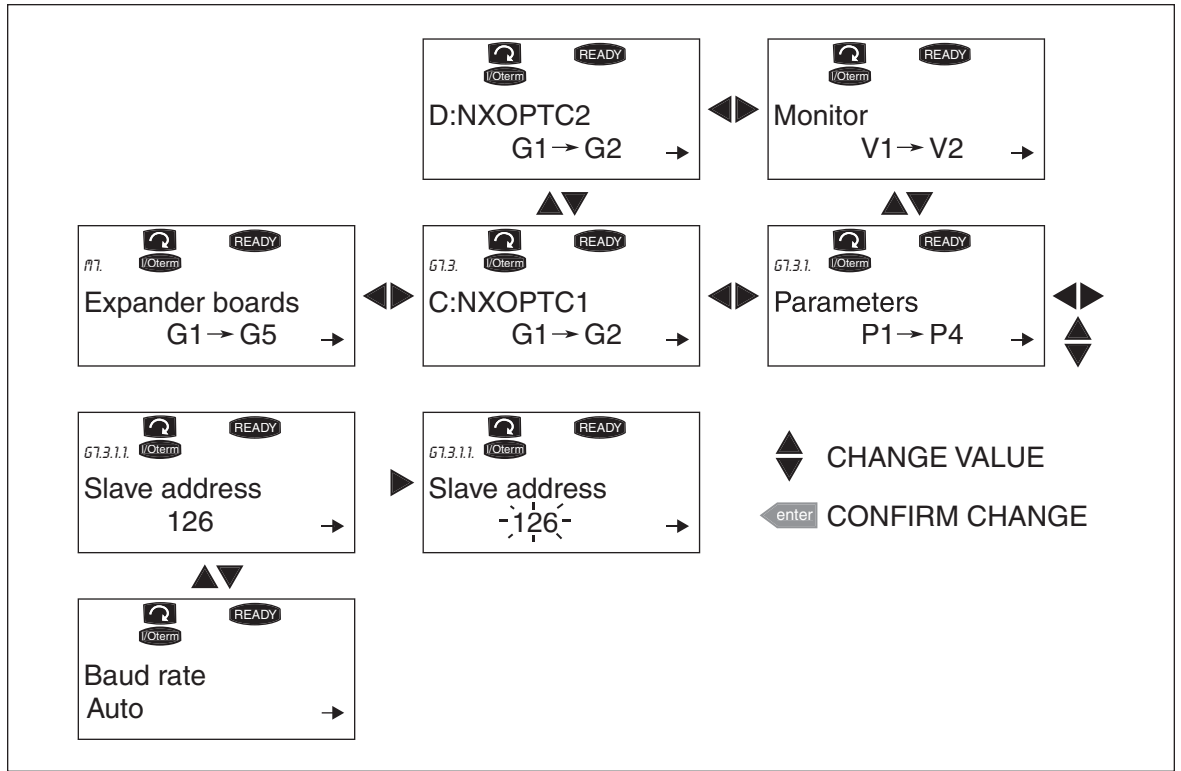
#### **Option Board Related Parameters for OPTA\_ Type Boards**

Some of the input and output functions of certain OPTA\_ type option boards are controlled with their associated parameters. The parameters are used to set the signal ranges for analog inputs and outputs, and values for the different encoder functions.

The board-related parameters can be edited in the *Expander Board Menu* of the control keypad.

By entering the next lower menu level with the *MENU button right*, you can browse through slots A to E with the *Browser button up* or *down* to see which expander boards are installed. On the lowermost line of the display you also see the number of parameters associated with the board. Edit the parameter value as shown below. For more information on the keypad operation, see your 9000X Series Drive User's Manual. **Figure 1-9** is an example of this type of menu structure.

October 2005



**Figure 1-9: Board Parameter Value Editing Example**

**Note:** Fieldbus boards (OPTC\_) also have fieldbus related parameters. These boards are described in the separate fieldbus board manuals.





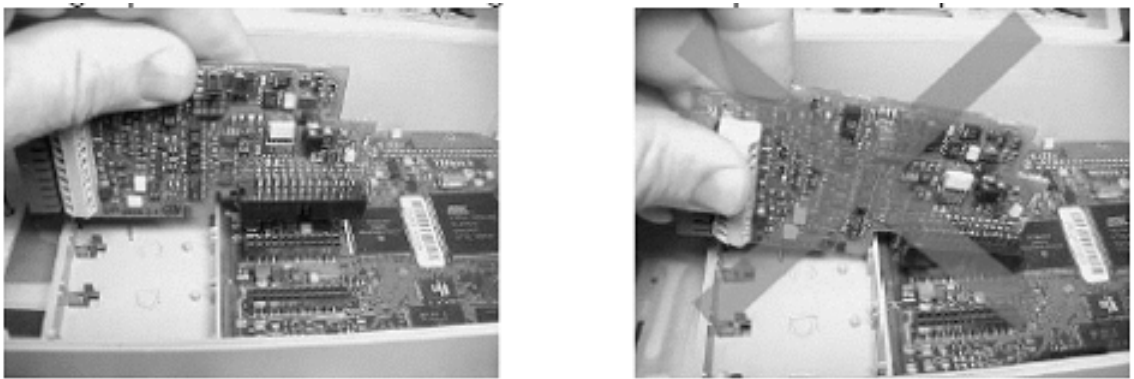
October 2005

## Chapter 2 — Option Board Installation

Remove utility line and control power from the 9000X Series Drive. Install the option board in the correct slot of the control board. To insert (and also to remove) the board, hold it in a horizontally straight position to avoid twisting the connector pins. See **Figure 2-1**.

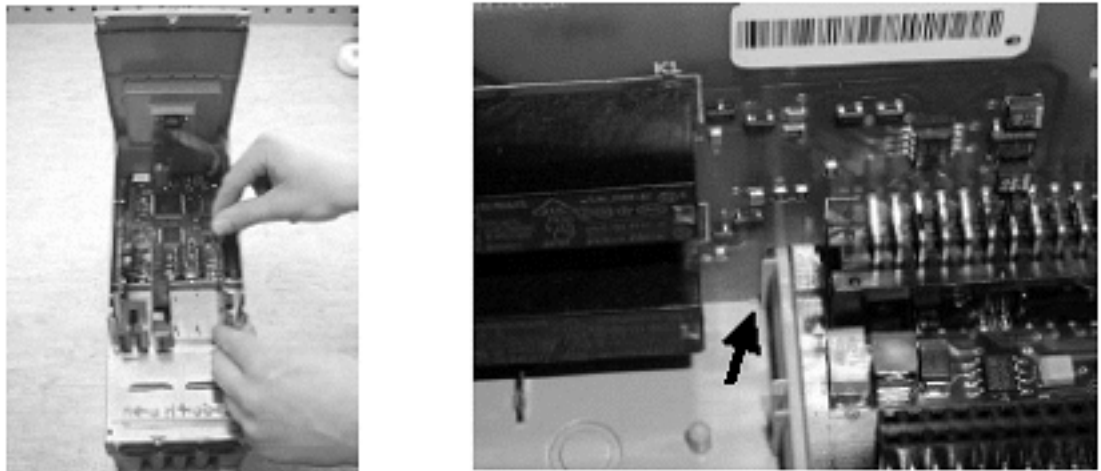
### CAUTION

Option boards and fieldbus boards must not be installed, removed or replaced while utility line or control power is applied to your 9000X Series Drive, to prevent board damage.



**Figure 2-1: Option Board Installation**

Make sure that the board (see **Figure 2-2**) fits tightly in the metal clamp and plastic groove. If the board seems to be difficult to install in the slot, you should confirm that you are using one of the allowed slots for the option board.



**Figure 2-2: Checking Option Board Installation**

**Note:** Check that the jumper settings on the board correspond to your needs. Finally, close the control unit cover of the 9000X Series Drive and any other opened covers.

## Control Wiring

The control wires shall be at least AWG 20 (0.5 mm<sup>2</sup>) shielded cables. The maximum wire size is AWG 14 (2.5 mm<sup>2</sup>) for the relay terminals and all terminals on A9 board and AWG 16 (1.5 mm<sup>2</sup>) for all other terminals.

The tightening torques for the option board terminals are listed in **Table 2-1**.

**Table 2-1: Tightening Torques for Control Terminals**

Terminal Screw	Tightening Torque	
	in./lbs.	Nm
Relay and thermistor terminals and others using an M3 screw	4.5	0.5
All other terminals using an M2.6 screw	1.8	0.2

## EMC Directive

For electrical equipment installed in the European Union (EU), the EMC directive states that the equipment must not disturb the environment and must be immune to other Electro Magnetic Disturbances in the environment. **Table 2-2** indicates the requirements for the control wiring to meet this directive.

**Table 2-2: Control Cable Type Required to Meet the EU EMC Standards**

Cable Type	Level H	Level C <sup>①</sup>
Control Cable	4 <sup>②</sup>	4 <sup>②</sup>

<sup>①</sup> Level H = EN 61800-3, 1st environment  
EN 50081-2

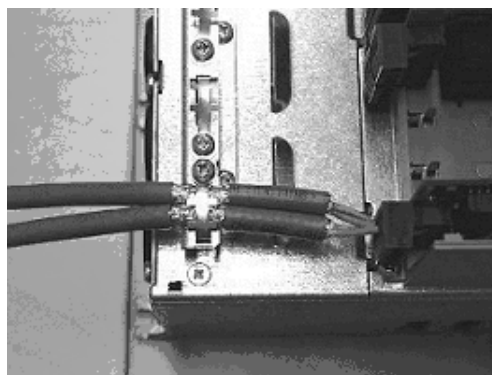
Level C = EN 50081-1

Also requires an external EMC filter between the 9000X Series Drive and the utility supply to meet the EMC requirements for the input power wiring.

<sup>②</sup> 4 = Shielded cable equipped with compact low-impedance shield.

## Control Cable Grounding

It is recommended that the control cables be grounded as shown in **Figure 2-3**. Strip the cable insulation as required to allow attachment to the frame with the grounding clamp.



**Figure 2-3: Control Cable Grounding**

October 2005

## Chapter 3 — OPTA\_ Option Boards

OPTA\_ option boards provide basic inputs and outputs (I/O) and are normally pre-installed at the factory in slots A, B and C.

The typical Eaton 9000X Series Drive contains two boards installed in slots A and B. The board in slot A (OPTA1, OPTA8 or OPTA9) has digital inputs, digital outputs, analog inputs and an analog output. The board usually in slot B (OPTA2) has two form C relay outputs. As an alternative an OPTA3 board can be used in slot B. In addition to the two relay outputs, this board has one thermistor input. **Table 3-1** illustrates the various OPTA\_ boards and their features.

**Table 3-1: OPTA\_ Board Features**

I/O Board	Allowed Slots	Digital Input (DI)	Digital Output (DO)	Analog Input (AI)	Analog Output (AO)	Relay Output (RO)	Thermistor Input (TI)	Other
OPTA1	A	6	1	2 (mA/V), incl. -10 – +10V	1 (mA/V)			+10V <sub>ref</sub> +24V/ EXT+24V
OPTA2	B					2 (NO/NC)		
OPTA3	B					1 (NO/NC) + 1 NO	1	
OPTA4	C	3 DI encoder (RS-422) + 2 DI (qualifier & fast input)						+5V/+15V/ +24V (progr.)
OPTA5	C	3 DI encoder (wide range) + 2 DI (qualifier & fast input)						+5V/+24V (progr.)
OPTA7	C	6 (enc.)	2 (enc.)					+15V/+24V (progr.)
OPTA8	A	6	1	2 (mA/V), incl. -10 – +10V (decoupled from GND)	1 (mA/V) (decoupled from GND)			+10V <sub>ref</sub> (decoupled from GND) +24V/ EXT+24V
OPTA9	A	6	1	2 (mA/V), incl. -10 – +10V	1 (mA/V)			+10V <sub>ref</sub> +24V/ EXT+24V
OPTAE	C	3 DI encoder (wide range)	2 (enc.)					+15V/+24V (progr.)

### Option Board A1

#### OPTA1

**Description:** Standard I/O board with digital inputs/outputs and analog inputs/outputs

**Allowed slots:** A

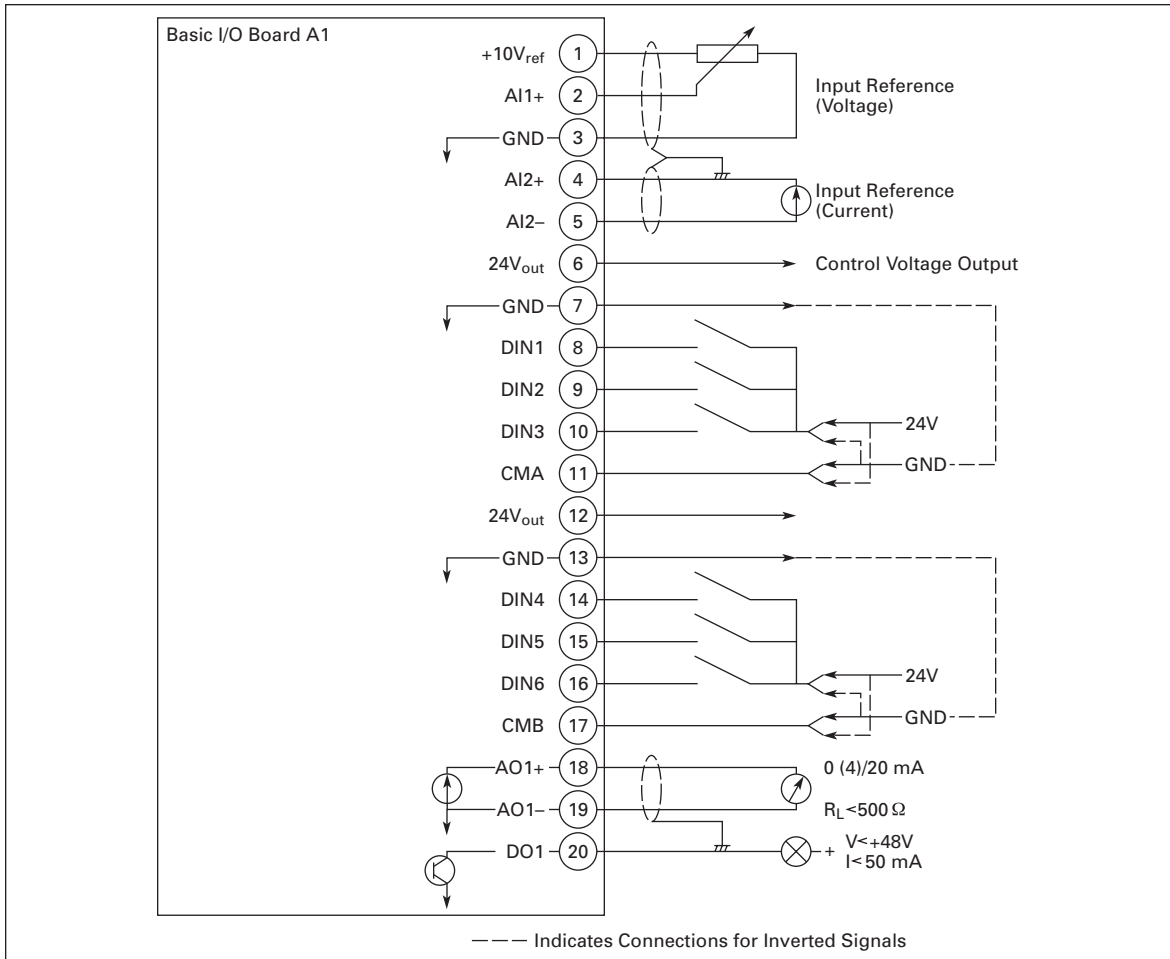
**Type ID:** 16689

**Terminals:** Two terminal blocks; Screw terminals (M2.6) (see **Figure 3-2**)

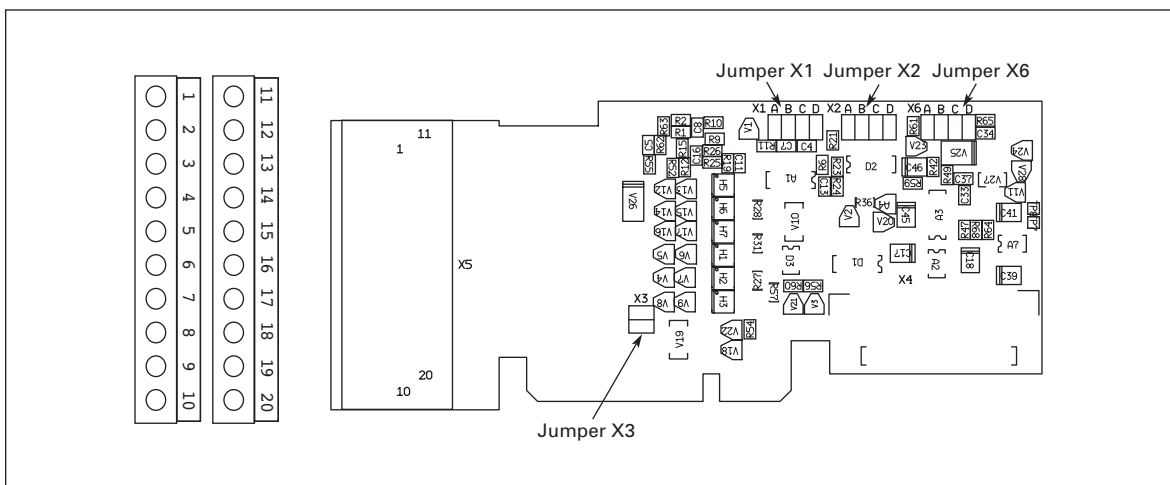
**Keying:** Terminals #1 and #12

**Jumpers:** 4; X1, X2, X3 and X6 (see **Figure 3-3**)

**Board parameters:** Yes (see **Table 3-3**)

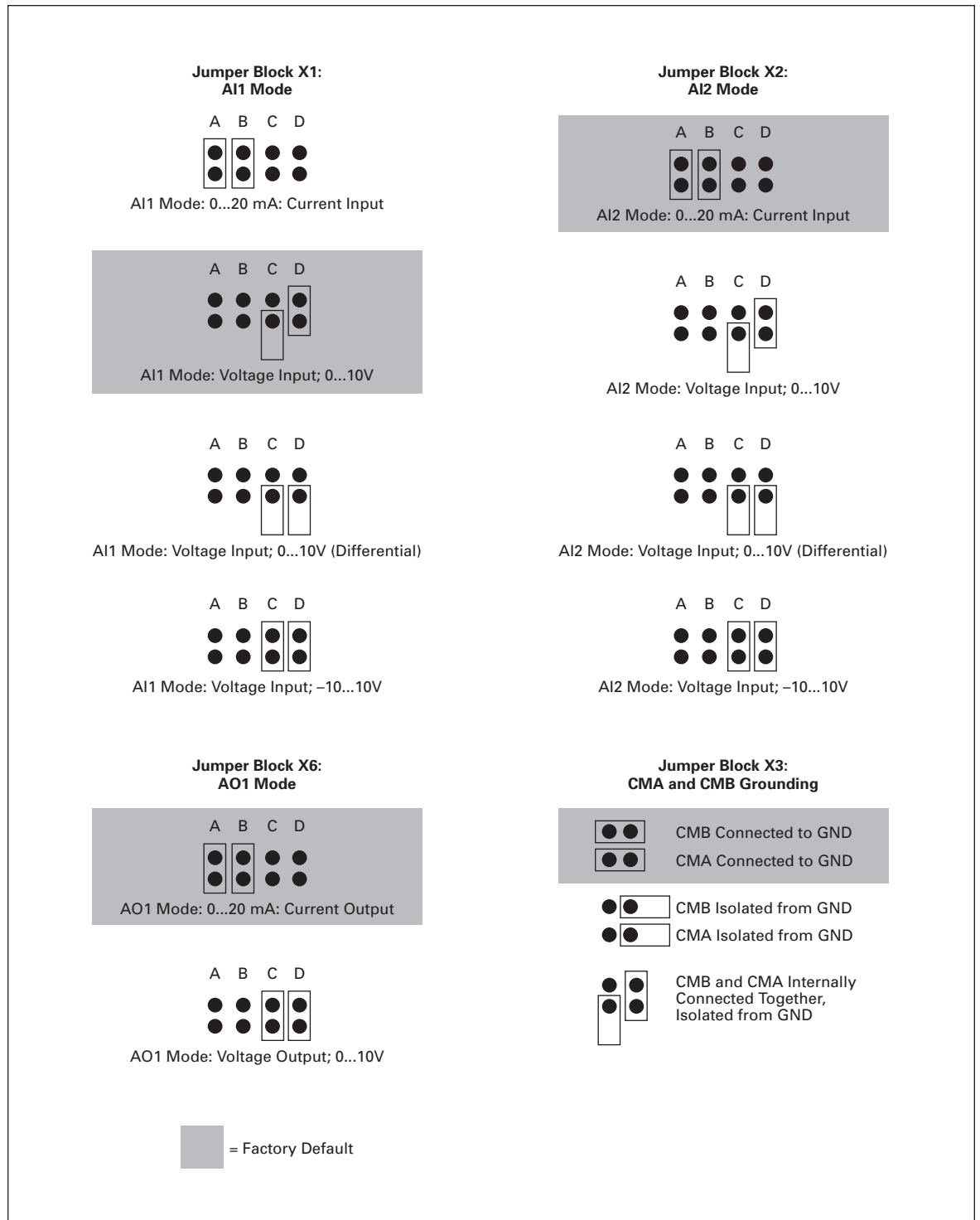


**Figure 3-1: Option Board A1 Wiring Diagram**



**Figure 3-2: Option Board A1 Jumper Locations**

October 2005



**Figure 3-3: Option Board A1 Jumper Settings**

**Table 3-2: Option Board A1 Terminal Descriptions**

Terminal	Signal (Keypad Parameter Reference)	Description and Parameter Reference
1	+10V <sub>ref</sub>	Reference voltage Maximum current 10 mA
2	AI1+	Analog input, voltage (An.IN:A.1) Default: 0 – +10V (R <sub>i</sub> = 200 kΩ); (-10V to +10V joystick control) 0 – 20 mA (R <sub>i</sub> = 250Ω) Select V or mA with jumper block X1 ( <b>Figure 3-3</b> ) Resolution 0.1%; Accuracy ±1%
3	GND/AI1-	Analog input common Differential input if not connected to ground; allows ±20V differential mode voltage to GND
4	AI2+	Analog input (An.IN:A.2) Default: 0 – 20 mA (R <sub>i</sub> = 250Ω) 0 – +10V (R <sub>i</sub> = 200 kΩ); (-10V to +10V joystick control) Select V or mA with jumper block X2 ( <b>Figure 3-3</b> ) Resolution 0.1%; Accuracy ±1%
5	GND/AI2-	Analog input common Differential input if not connected to ground; allows ±20V differential mode voltage to GND
6	24V <sub>out</sub>	24V control voltage (bi-directional) ±15%, 250 mA (all boards total); 150 mA (max. current from single board); short circuit protected; Can be used as external power backup for the control (and fieldbus); Galvanically connected to terminal #12
7	GND	I/O ground Ground for reference and controls; Galvanically connected to terminals #13, 19
8	DIN1	Digital input 1 (Dig.IN:A.1) R <sub>i</sub> = min. 5 kΩ
9	DIN2	Digital input 2 (Dig.IN:A.2) R <sub>i</sub> = min. 5 kΩ
10	DIN3	Digital input 3 (Dig.IN:A.3) R <sub>i</sub> = min. 5 kΩ
11	CMA	Digital input common A for DIN1, DIN2 and DIN3 Must be connected to GND or 24V of I/O terminals or external 24V or GND. Default connected to GND. Selection with jumper block X3. ( <b>Figure 3-3</b> ).
12	24V <sub>out</sub>	24V control voltage (bi-directional) Same as terminal #6; Galvanically connected to terminal #6
13	GND	I/O ground Same as terminal #7; Galvanically connected to terminals #7 & 19
14	DIN4	Digital input 4 (Dig.IN:A.4) R <sub>i</sub> = min. 5 kΩ
15	DIN5	Digital input 5 (Dig.IN:A.5) R <sub>i</sub> = min. 5 kΩ
16	DIN6	Digital input 6 (Dig.IN:A.6) R <sub>i</sub> = min. 5 kΩ
17	CMB	Digital input common B for DIN4, DIN5 and DIN6 Must be connected to GND or 24V of I/O terminals or external 24V or GND. Default connected to GND. Select with jumper block X3. ( <b>Figure 3-3</b> ).
18	AO1+	Analog signal (+output) (An.OUT:A.1) Output signal range: Current: 0(4) – 20 mA, R <sub>L</sub> max. 500Ω or Voltage: 0 – 10V, R <sub>L</sub> >1 kΩ (default setting) Selection with jumper block X6. ( <b>Figure 3-3</b> ) Resolution: 0.1% (10 bits); Accuracy ±2%
19	AO1-	Analog output common Galvanically connected to terminals #7, 13
20	DO1	Digital output 1 (Dig.OUT:A.1) Open collector output, maximum current = 50 mA, maximum voltage = 48V DC

October 2005

**Table 3-3: Option Board A1 Parameters**

Number	Parameter	Min.	Max.	Default	Note
1	AI1 mode	1	5	3	1 = 0 – 20 mA 2 = 4 – 20 mA 3 = 0 – 10V 4 = 2 – 10V 5 = -10 – +10V
2	AI2 mode	1	5	1	1 = 0 – 20 mA 2 = 4 – 20 mA 3 = 0 – 10V 4 = 2 – 10V 5 = -10 – +10V
3	AO1 mode	1	4	1	1 = 0 – 20 mA 2 = 4 – 20 mA 3 = 0 – 10V 4 = 2 – 10V

**Option Board A2**

**OPTA2**

**Description:** Standard relay board with two relay outputs

**Allowed slots:** B

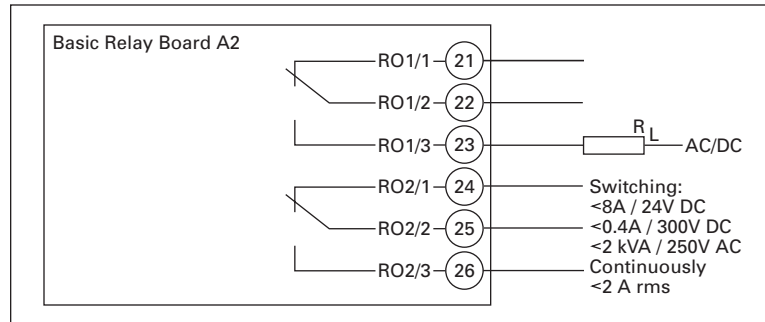
**Type ID:** 16690

**Terminals:** Two terminal blocks; Screw terminals (M3) (see **Figure 3-5**)

**Keying:** None

**Jumpers:** None

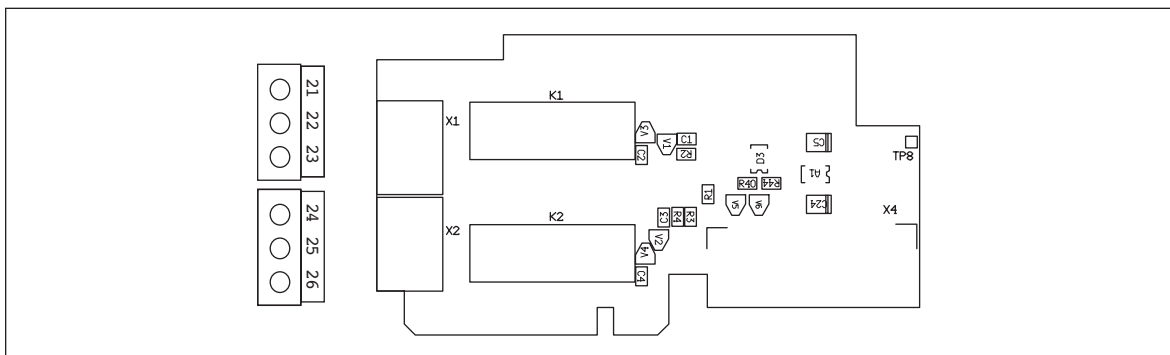
**Board parameters:** None



**Figure 3-4: Option Board A2 Wiring Diagram**

**Table 3-4: Option Board A2 Terminal Descriptions**

Terminal	Signal	Keypad Parameter Reference	Technical Information
21	RO1/1 Normally Closed (NC)	DigOUT:B.1	Switching capacity: 24V DC/8A 250V AC/8A 125V DC/0.4A Min. switching load: 5V/10 mA Continuous capacity: < 2A rms
22	RO1/2 Common		
23	RO1/3 Normally Open (NO)		
24	RO2/1 Normally Closed (NC)	DigOUT:B.2	Switching capacity: 24V DC/8A 250V AC/8A 125V DC/0.4A Min. switching load: 5V/10 mA Continuous capacity: < 2A rms
25	RO2/2 Common		
26	RO2/3 Normally Open (NO)		



**Figure 3-5: Option Board A2 Terminal Locations**

**Option Board A3**

*OPTA3*

**Description:** Relay board with two relay outputs and one thermistor input

**Allowed slots:** B

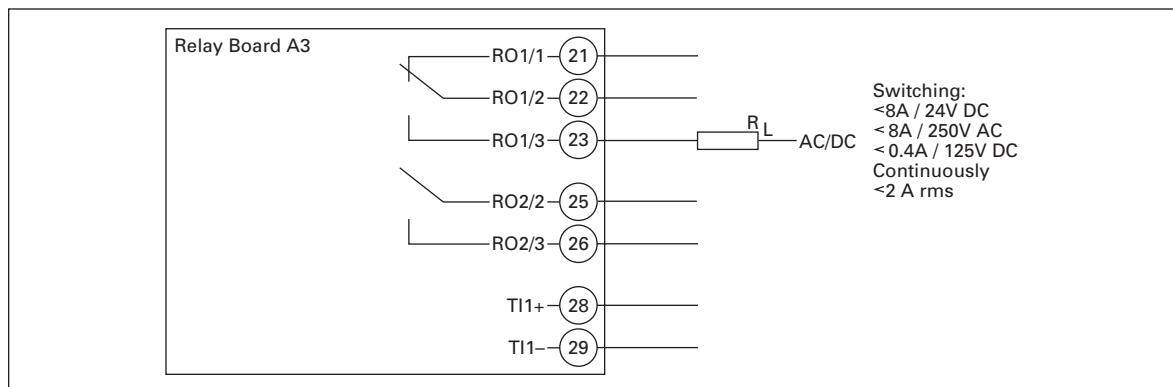
**Type ID:** 16691

**Terminals:** Three terminal blocks; Screw terminals (M3) (see **Figure 3-7**)

**Keying:** None

**Jumpers:** None

**Board parameters:** None



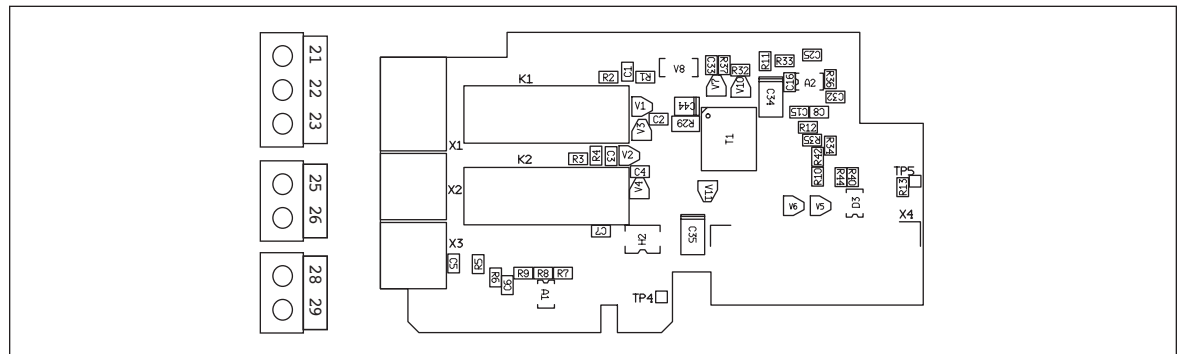
**Figure 3-6: Option Board A3 Wiring Diagram**



October 2005

**Table 3-5: Option Board A3 Terminal Descriptions**

Terminal	Function	Keypad Parameter Reference	Technical Information
21	RO1/1 Normally Closed (NC)	DigOUT:B.1	Switching capacity: 24V DC/8A 250V AC/8A 125V DC/0.4A Min. switching load: 5V/10 mA Continuous capacity: < 2A rms
22	RO1/2 Common		
23	RO1/3 Normally Open (NO)		
25	RO2/2 Common	DigOUT:B.2	Switching capacity: 24V DC/8A 250V AC/8A 125V DC/0.4A Min. switching load: 5V/10 mA Continuous capacity: < 2A rms
26	RO2/3 Normally Open (NO)		
28	TI1+	DigIN:B.1	Thermistor input; $R_{trip} = 4.7\text{ k}\Omega$ (PTC)
29	TI1-		



**Figure 3-7: Option Board A3 Terminal Locations**

**Option Board A4 (SPX9000 Only)**

**OPTA4**

**Description:** Encoder input board with a programmable control voltage for the encoder.

This board is for TTL type encoders (TTL, TTL(R)) providing input signal levels that meet the RS-422 interface standard. Encoder inputs A, B and Z are *not* galvanically isolated. This board also includes the qualifier input ENC1Q (meant to trace the Z-pulse in certain situations) and a special/fast digital input DIC4 (used to trace very short pulses). These two inputs are used in special applications.

TTL type encoders do not have an internal regulator and must use a supply voltage of +5V±5%, whereas the TTL(R) type encoders have an internal regulator and can have a supply voltage of +15V±10% (depending on the encoder manufacturer).

**Allowed slots:** C

**Type ID:** 16692

**Terminals:** One terminal block; Screw terminals (M2.6) (see **Figure 3-9**)

**Keying:** Terminal #3

**Jumpers:** 1; X4 (see **Figure 3-8**)

**Board parameters:** Yes (see **Table 3-8**)

**Table 3-6: Option Board A4 Terminal Descriptions**

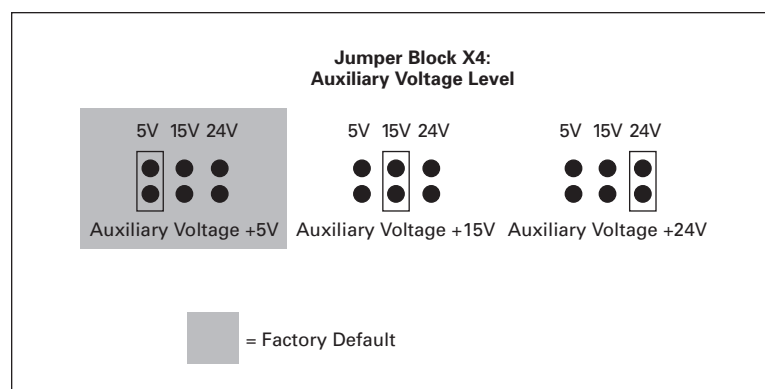
Terminal	Description and Parameter Reference
1	DIC1A+
2	DIC1A-
3	DIC2B+
4	DIC2B-
5	DIC3Z+
6	DIC3Z-
7	ENC1Q
8	DIC4
9	GND
10	+5V/+15V/ +24V

**Table 3-7: Option Board A4 Technical Data**

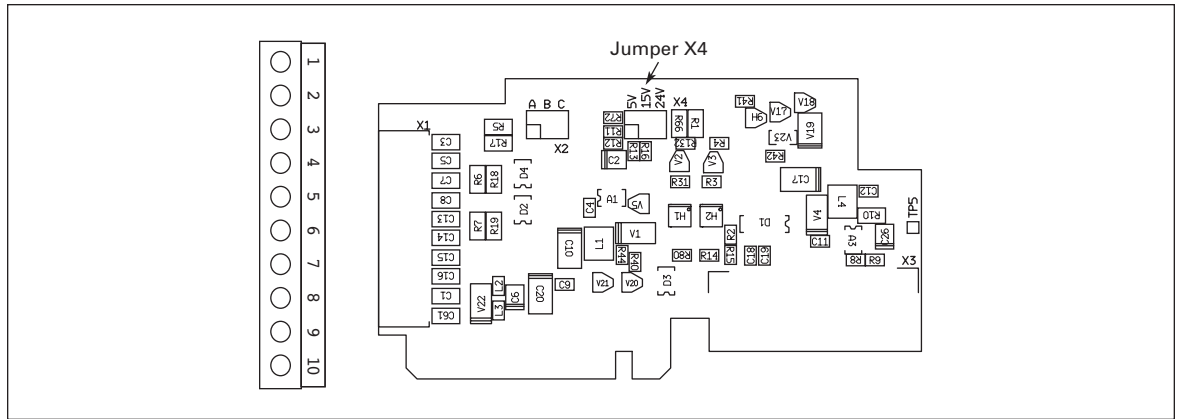
Function	Technical Information
Encoder control voltage, +5V/+15V/+24V	Control voltage selectable with jumper X4
Encoder input connections Inputs A+, A-, B+, B-, Z+, Z-	Maximum input frequency $\leq 300$ kHz Inputs A, B and Z are differential Encoder inputs are RS-422 interface compatible Maximum load per encoder input $I_{low} = I_{high} \approx 25$ mA
Qualifier input ENC1Q	Maximum input frequency $\leq 10$ kHz
Fast digital input DIC1	Minimum pulse length $50 \mu\text{s}$ Digital input 24V; $R_i > 5$ k $\Omega$ Digital input is single ended, connected to GND

**Jumper Selections**

There is one jumper block on the OPTA4 board. Jumper block **X4** is used to program the control (auxiliary) voltage. **Figure 3-8** shows the jumper selections and the default position.

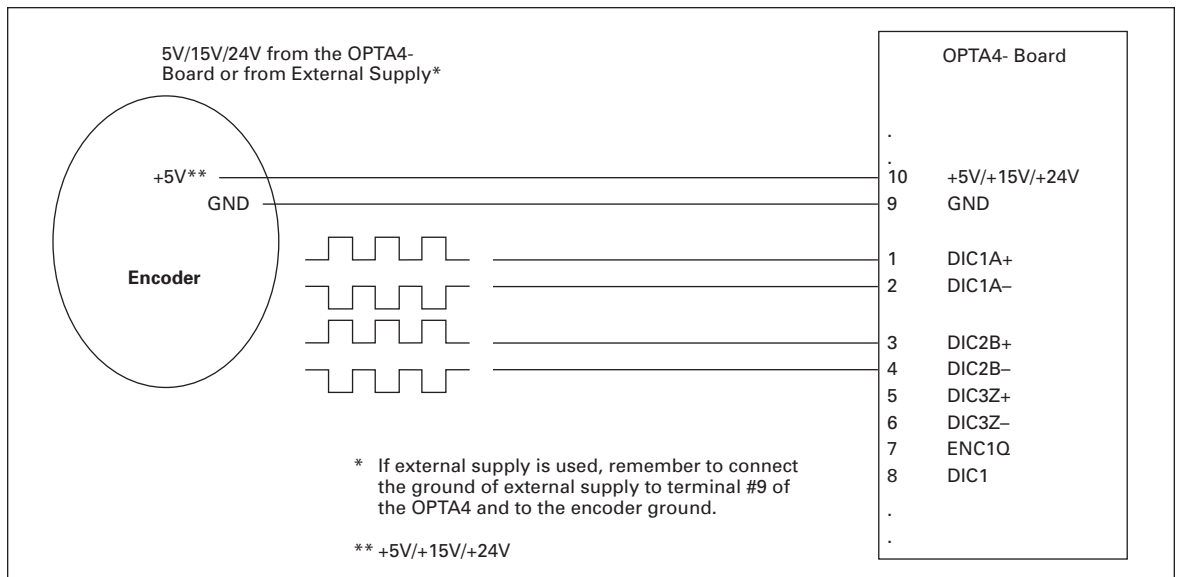
**Figure 3-8: Jumper Positions for Option Board A4**

October 2005



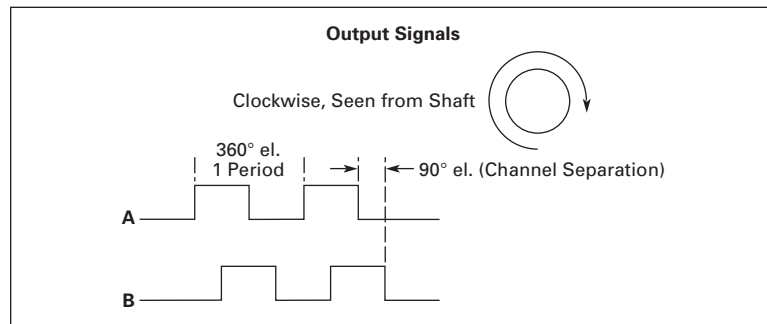
**Figure 3-9: Option Board A4 Terminal and Jumper Locations**

**Encoder Connection — Differential Inputs**



**Figure 3-10: Option Board A4 Encoder Connection Using Differential Inputs**

**Note:** The encoder pulses are processed by the 9000X Series Drive as indicated in **Figure 3-11**.



**Figure 3-11: Option Board A4 Encoder**

**Table 3-8: Option Board A4 Parameters**

Parameter	Minimum	Maximum	Default	Note
Pulse/revolution	1	65535	1024	
Invert direction	0	1	0	0 = Yes 1 = No
Reading rate <sup>①</sup>	0	4	1	0 = No 1 = 1 mS 2 = 5 mS 3 = 10 mS 4 = 50 mS

<sup>①</sup> Time used to calculate the actual value of speed. Use the value 1 when in Closed Loop mode.

## Option Board A5 (SPX9000 Only)

### OPTA5

**Description:** Encoder input board with a programmable control voltage for an encoder.

This board is for HTL (High voltage Transistor Logic) type encoders (voltage output type push-pull HTL, open collector output type HTL) providing input signal levels which are dependent upon the supply voltage of the encoder. Encoder inputs A, B and Z are galvanically isolated. This board also includes the qualifier input ENC1Q (meant to trace the Z-pulse in certain situations) and a special/fast digital input DIC4 (used to trace very short pulses). These two inputs are used in special applications.

The OPTA5 connections are similar to the OPTA4, but the encoder inputs A, B and Z have different signal levels (voltage). The input levels are general wide range inputs, not compatible with RS-422 levels. Inputs ENC1Q and DIC4 are identical for both boards.

**Allowed slots:** C

**Type ID:** 16693

**Terminals:** One terminal block; Screw terminals (M2.6) (see **Figure 3-13**)

**Keying:** Terminal #3

**Jumpers:** 1; X4 (see **Figure 3-12**)

**Board parameters:** Yes (see **Table 3-11**)

**Table 3-9: Option Board A5 Terminal Descriptions**

Terminal	Description and Parameter Reference
1	DIC1A+
2	DIC1A-
3	DIC2B+
4	DIC2B-
5	DIC3Z+
6	DIC3Z-
7	ENC1Q
8	DIC4
9	GND
10	+15V/+24V

**NOTE:** The encoder inputs are wide range inputs that can be used with encoders rated for +15V or +24V.

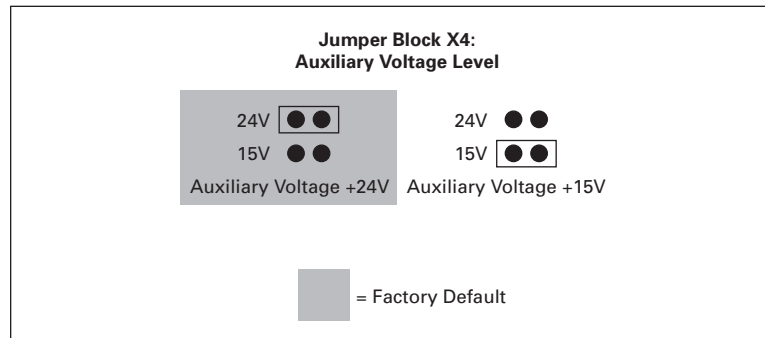
October 2005

**Table 3-10: Option Board A5 Technical Data**

Function	Technical Information
Encoder control voltage, +15V/+24V	Control voltage selectable with jumper X4
Encoder input connections Inputs A+, A-, B+, B-, Z+, Z-	Maximum input frequency $\leq 300$ kHz Inputs A, B and Z are differential
Qualifier input ENC1Q	Maximum input frequency $\leq 10$ kHz Minimum pulse length $50 \mu$ S
Fast digital input DIC1	Digital input 24V; $R_i > 5$ k $\Omega$ Digital input is single ended, connected to GND

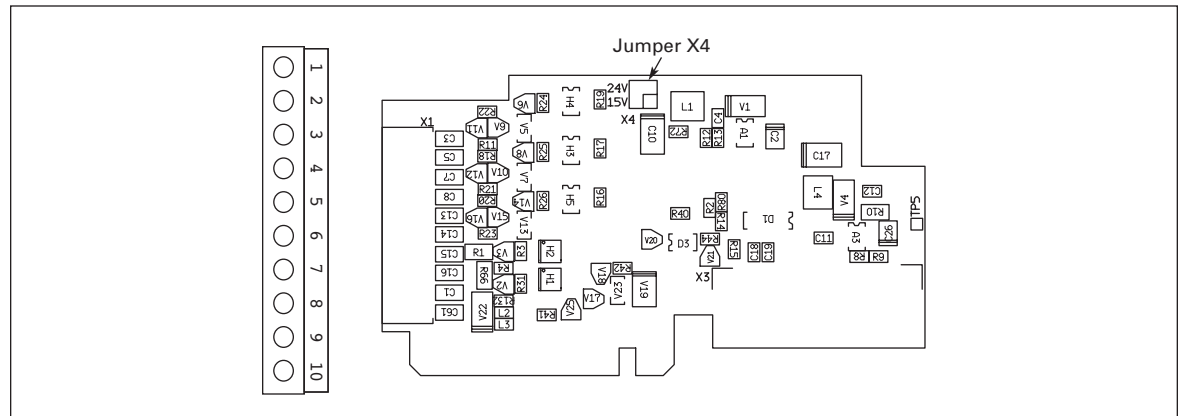
**Jumper Selections**

There is one jumper block on the OPTA5 board. Jumper block X4 is used to program the control (auxiliary) voltage. **Figure 3-12** shows the jumper selections and the default position.



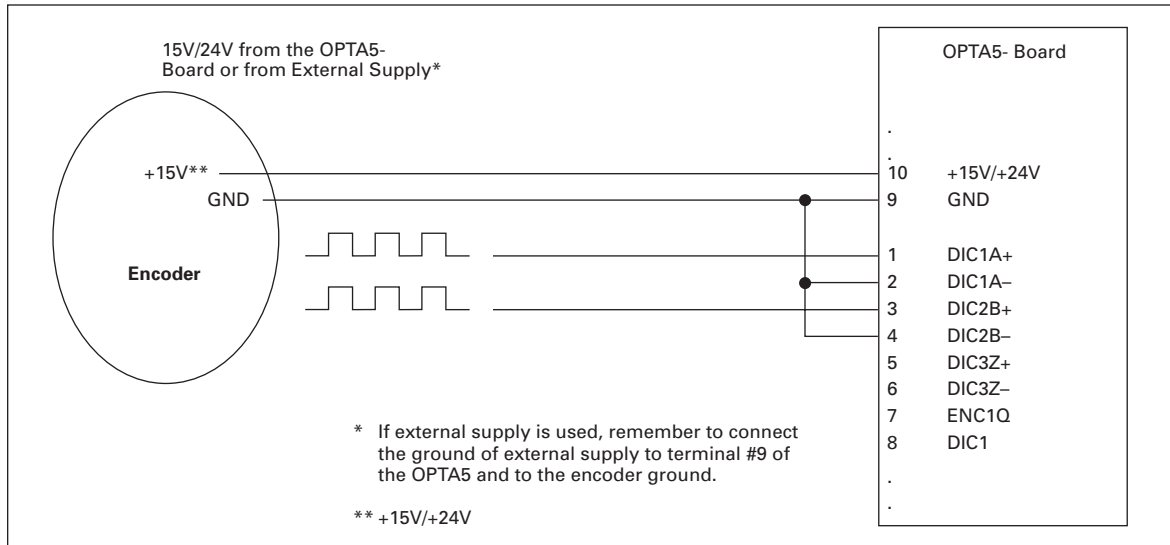
**Figure 3-12: Jumper Positions for Option Board A5**

The typical usage for this board is for closed loop vector control. The OPTA5 is used in conventional industrial applications where the cable lengths between the 9000X Series Drive and the connected encoder are relatively long.

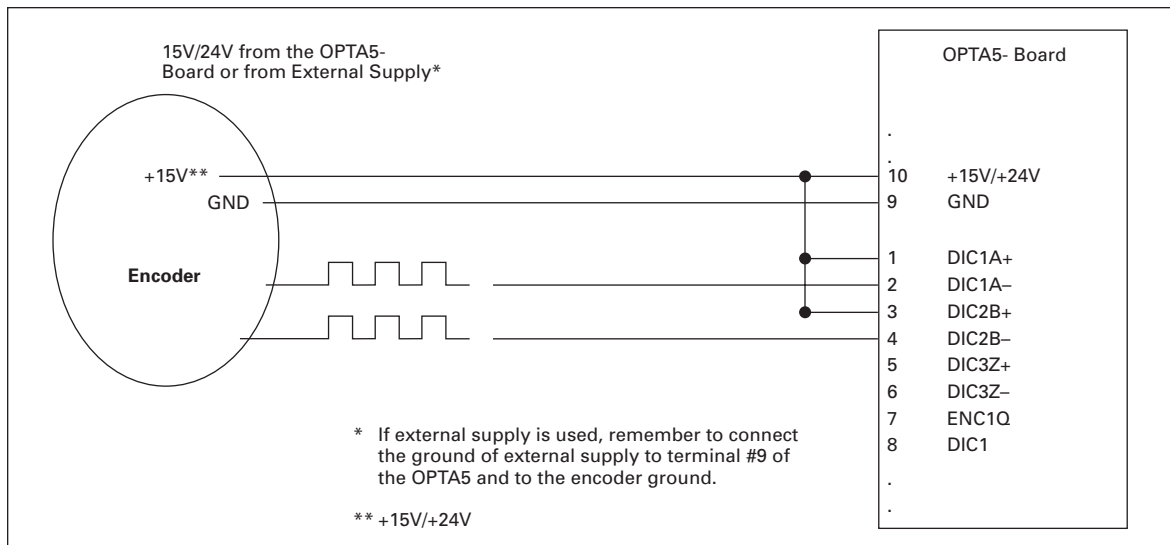


**Figure 3-13: Option Board A5 Terminal and Jumper Locations**

**Encoder Connection — Single Ended**

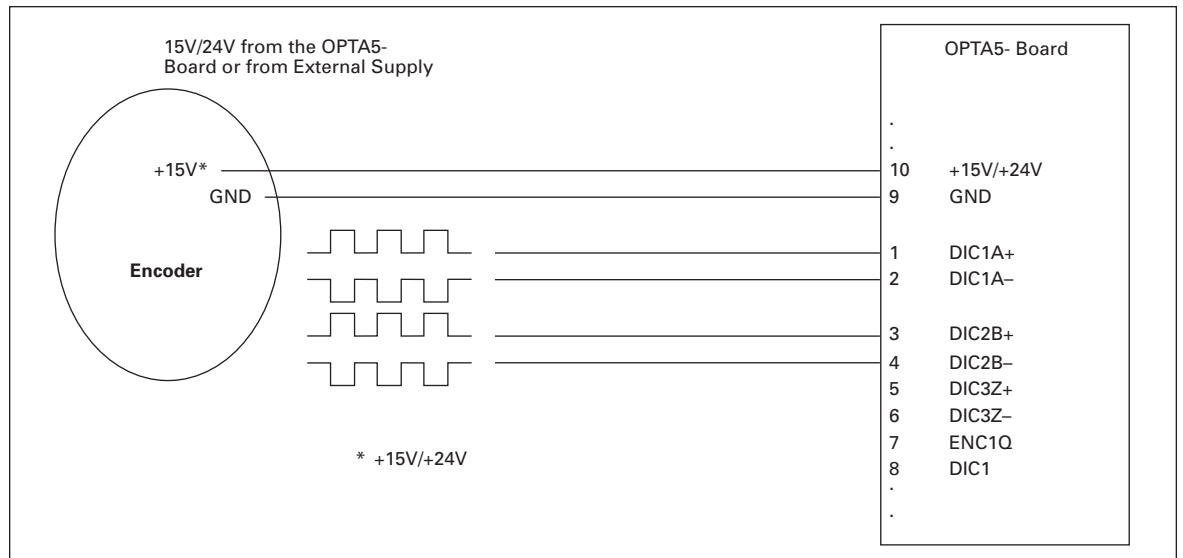


**Figure 3-14: HTL Type Encoder Connection (Open Source) Using Single-Ended Inputs**



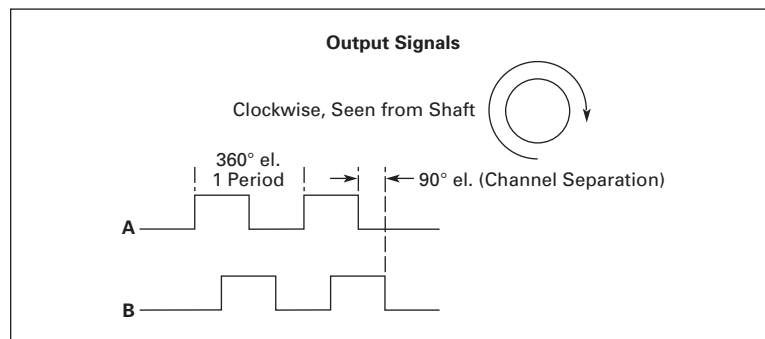
**Figure 3-15: HTL Type Encoder Connection (Open Collector) Using Single-Ended Inputs**

October 2005



**Figure 3-16: HTL Type Encoder Connection Using Differential Inputs**

**Note:** The encoder pulses are processed by the 9000X Series Drive as indicated in **Figure 3-17**.



**Figure 3-17: Option Board A5 Encoder**

**Table 3-11: Option Board A5 Parameters**

Parameter	Minimum	Maximum	Default	Note
Pulse/revolution	1	65535	1024	
Invert direction	0	1	0	0 = Yes 1 = No
Reading rate <sup>①</sup>	0	4	1	0 = No 1 = 1 mS 2 = 5 mS 3 = 10 mS 4 = 50 mS

<sup>①</sup> Time used to calculate the actual value of speed. Use the value 1 when in Closed Loop mode.

## Option Board A7 (SPX9000 Only)

### OPTA7

**Description:** Duplicate encoder board for 9000X drives. Encoder input board with programmable control voltage for the encoder.

The OPTA7 board is designed for HTL (High voltage Transistor Logic) type encoders (voltage output type push-pull HTL, open collector output type HTL) which provide input signal levels dependent on the supply voltage of the encoder. The encoder inputs A, B and Z are galvanically isolated. The OPTA7 board also includes the qualifier inputs ENC1Q and ENC2Q meant to trace positions in positioning applications.

The board can be used as both *Master* and *Slave* device. The encoder input signal is repeated on the board and carried to the next device through the digital output.

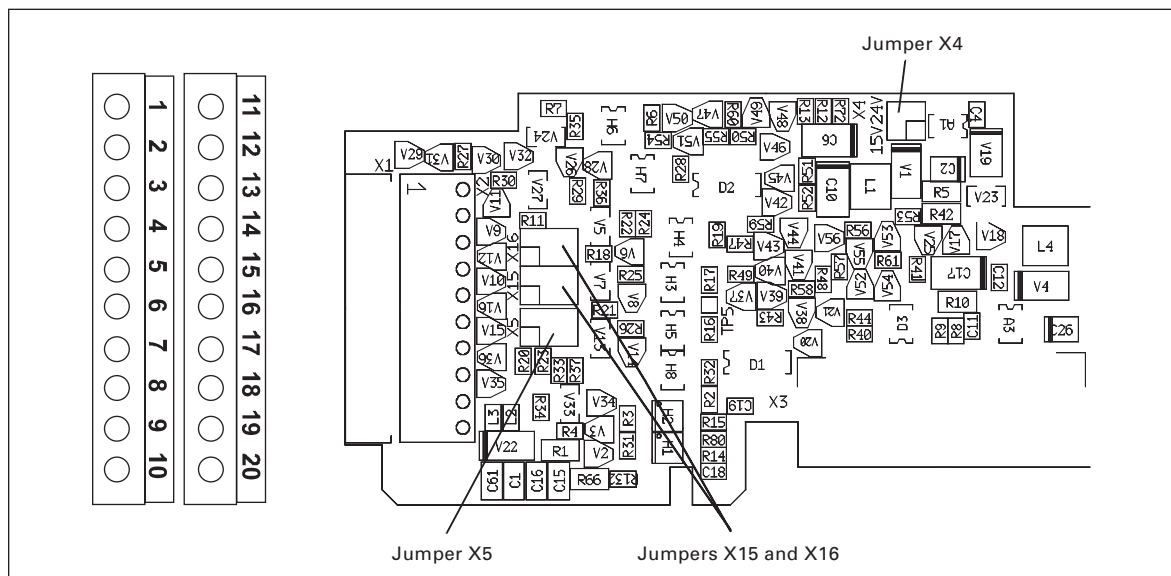
**Allowed slots:** C

**Type ID:** 16695

**Terminals:** Two terminal blocks; Screw terminals (M2.6); Coding in terminals #3 and #14

**Jumpers:** 4; X4, X5, X15 and X16 (see **Page 3-16**)

**Board parameters:** None



**Figure 3-18: Option Board A7 Terminal and Jumper Locations**



October 2005

**Table 3-12: Option Board A7 Terminal Descriptions**

Terminal	Description and Parameter Reference
1	DIC1A+
2	DIC1A-
3	DIC2B+
4	DIC2B-
5	DIC3Z+
6	DIC3Z-
7	ENC1Q
8	ENC2Q
9	GND
10	+15V/+24V
11	DID1A+
12	DID1A-
13	DID2B+
14	DID2B-
15	DID3Z+
16	DID3Z-
17	DOD1A+
18	DOD1A-
19	DOD2B+
20	DOD2B-

**Note:** Encoder inputs are wide range inputs that can be used with encoders using +15V or +24V.

**Table 3-13: Option Board A7 Technical Data**

Function	Technical Information
Encoder control voltage, +15V/+24V	Control voltage selectable with jumper X4.
Encoder input connections, inputs A+, A-, B+, B-, Z+, Z-	Max. input frequency $\leq 150$ kHz Inputs A, B and Z are differential
Qualifier input ENC1Q	Max. input frequency $\leq 10$ kHz Min. pulse length $50\mu\text{S}$
Fast digital input DIC1	Digital input 24V; $R_i > 5$ k $\Omega$ Digital input is single-ended; connected to GND

**Note:** A high pulse frequency combined with a great cable capacitance places a considerable load on the encoder. Apply therefore as low a voltage as possible for the encoder supply, rather lower than 24V. The manufacturer also recommends to place jumper X4 to position +15V, if allowed in the voltage range specification of the encoder.

### Jumper Selections

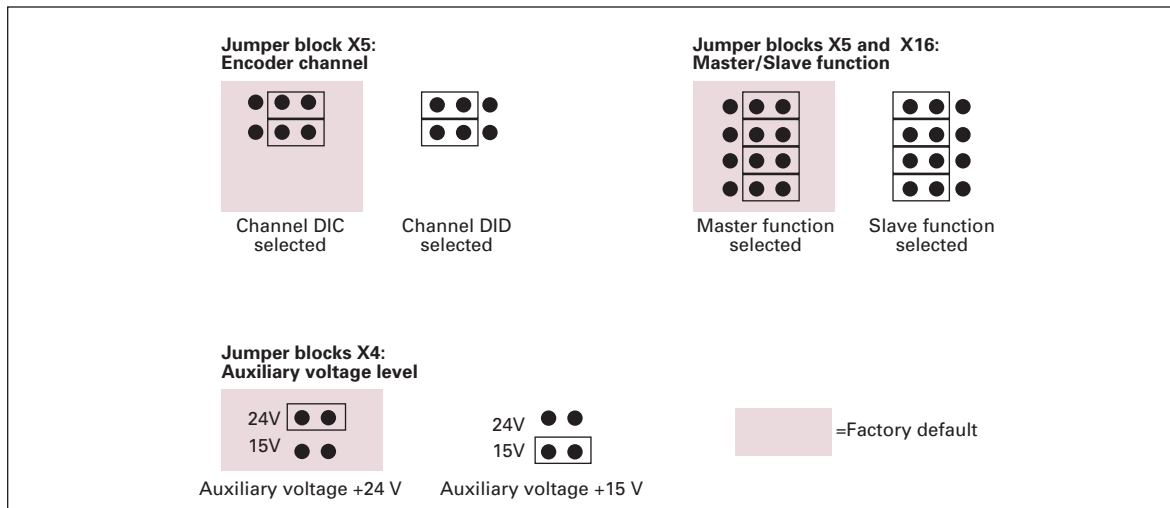
On the OPTA7 board, there are four jumper blocks.

Jumper **X4** is used to program the control voltage (auxiliary voltage).

The setting of jumper **X5** defines the encoder channel (DIC/DID) used to carry the signal to the repeater.

The setting of jumpers **X15** and **X16** is changed according to whether the board is used as a *Master* or *Slave* device.

The factory default and other available jumper selections are presented below.



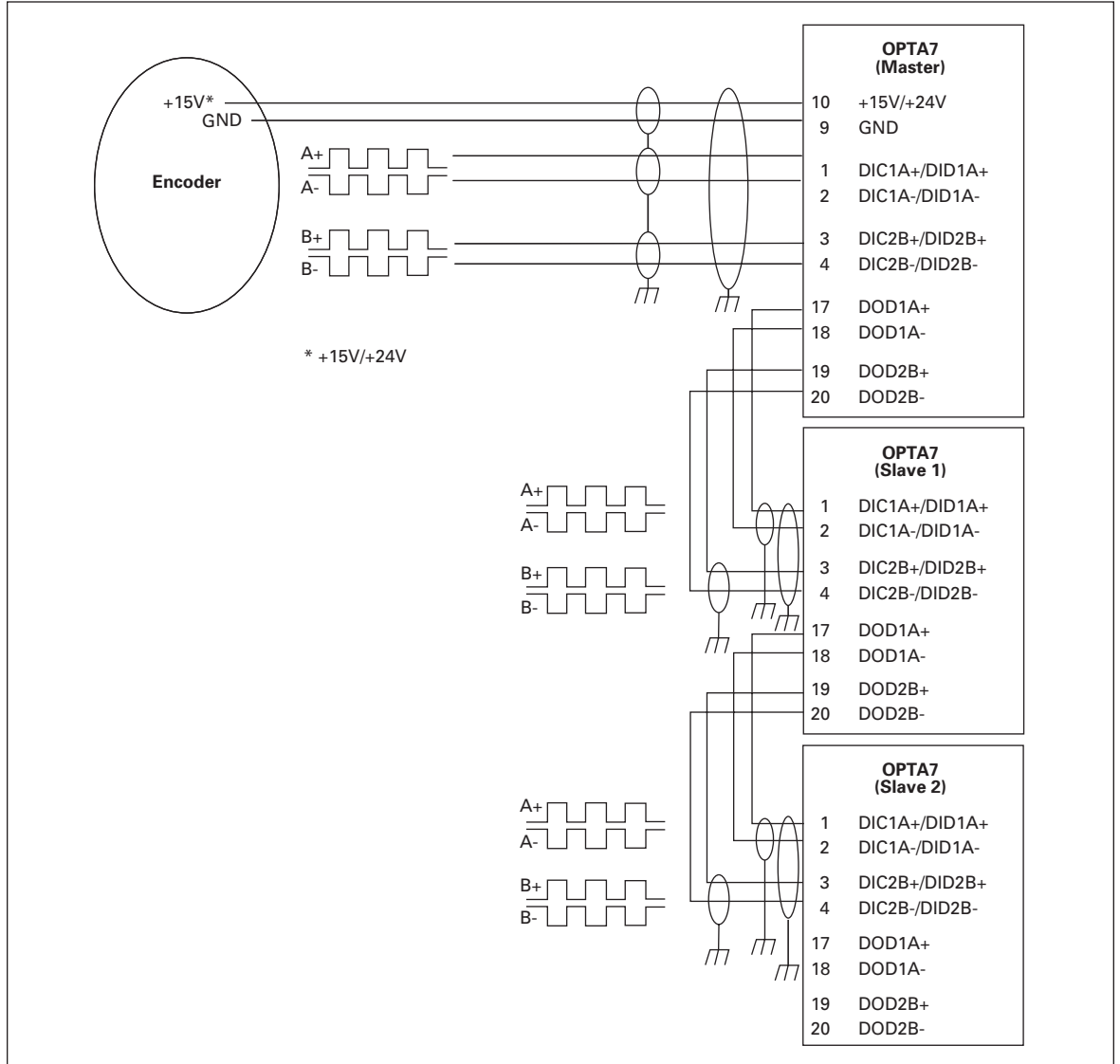
**Figure 3-19: Jumper Positions for Option Board A7**

**Usage:** Closed Loop Vector Control, positioning applications. The OPTA7 encoder board is mainly used in demanding system applications, e.g. when measuring the motor speed with two encoders.

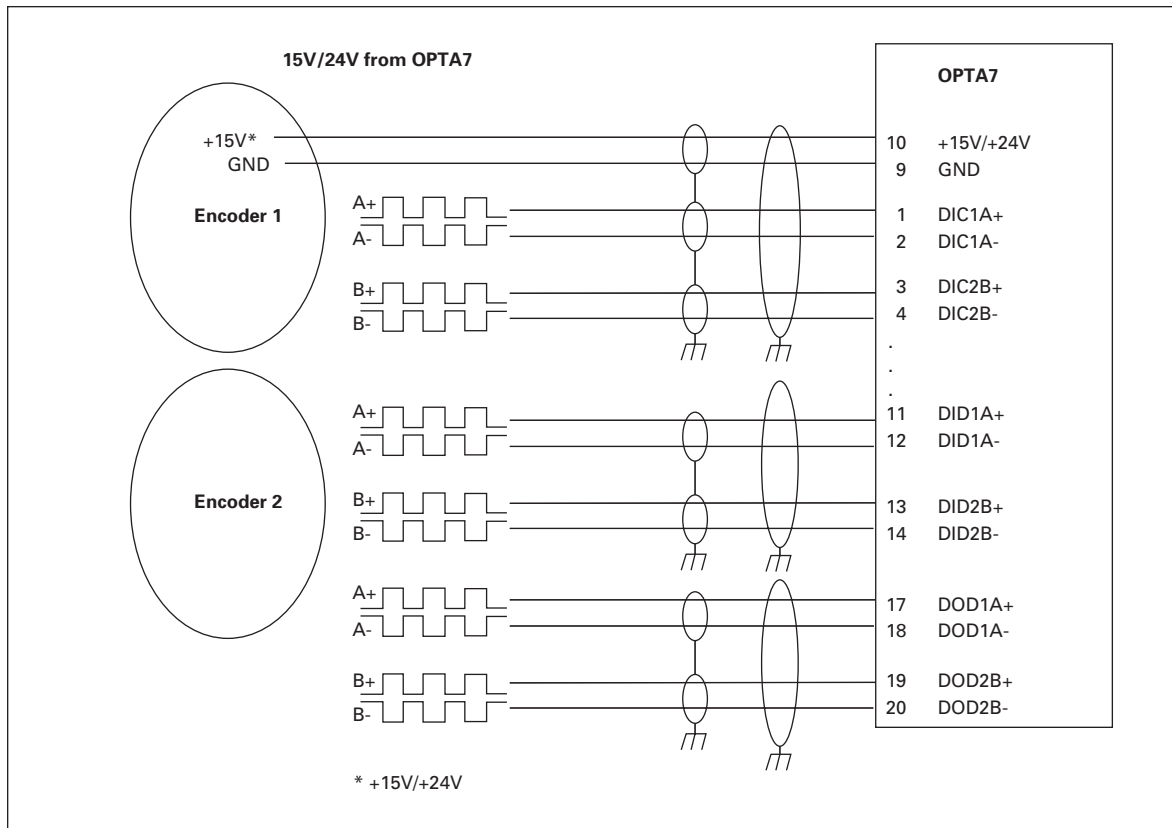
October 2005

**Encoder Connection**

The figures below present examples of a chain connection of several OPTA7 boards (**Figure 3-20**) and a connection of two encoders to the OPTA7 option board (**Figure 3-21**).



**Figure 3-20: Connection of Encoder and Three OPTA7 Boards**



**Figure 3-21: Connection of Two Encoders to OPTA7 Board**

October 2005

## Option Board A8

### OPTA8

**Description:** I/O board similar to OPTA1 except that the analog inputs/outputs are galvanically isolated.

**Allowed slots:** A

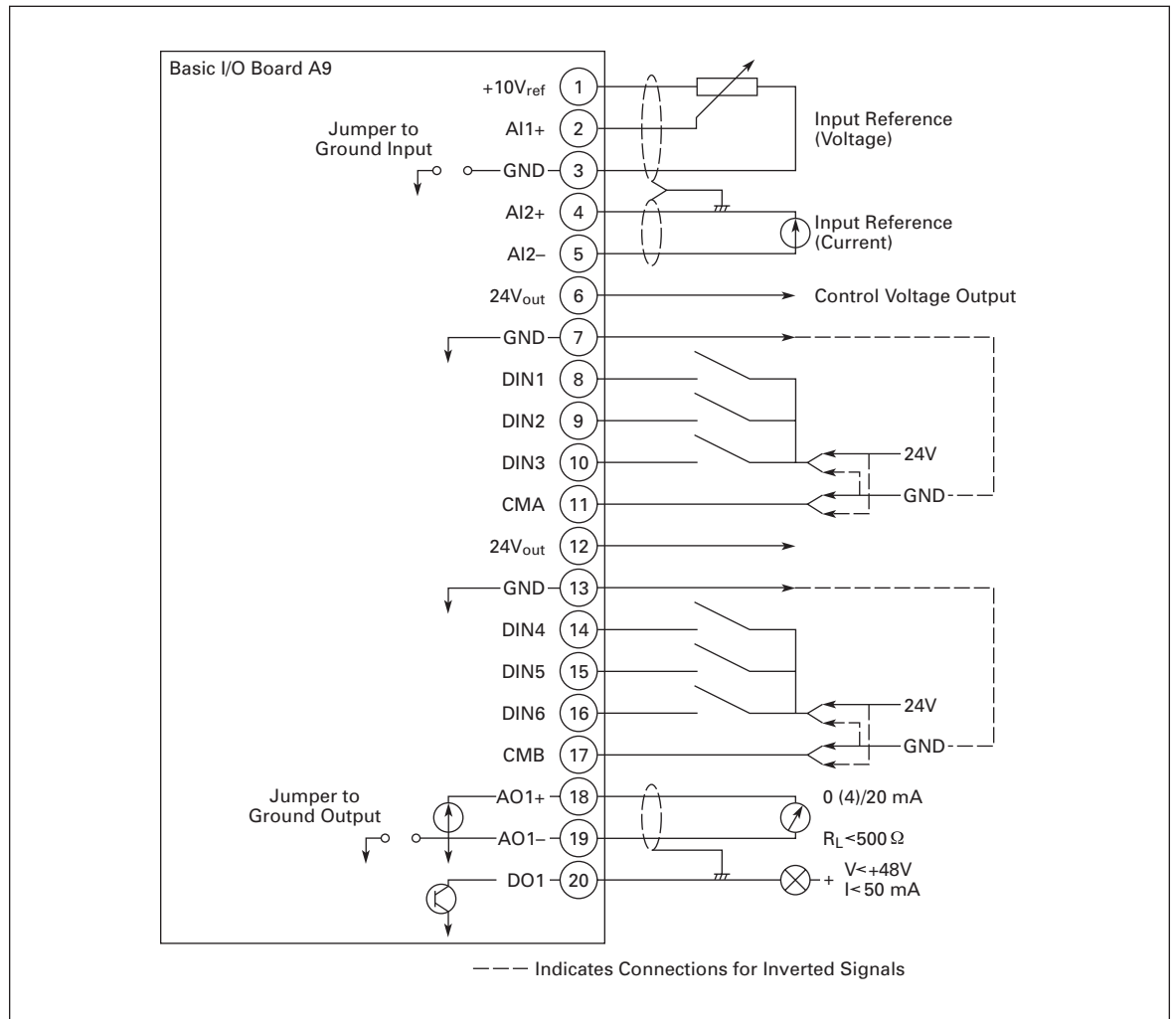
**Type ID:** 16696

**Terminals:** Two terminal blocks; Screw terminals (M2.6) (see **Figure 3-23**)

**Keying:** Terminals #1 and #12

**Jumpers:** 4; X1, X2, X3 and X6 (see **Figure 3-24**)

**Board parameters:** Yes (see **Table 3-15**)



**Figure 3-22: Option Board A8 Wiring Diagram**

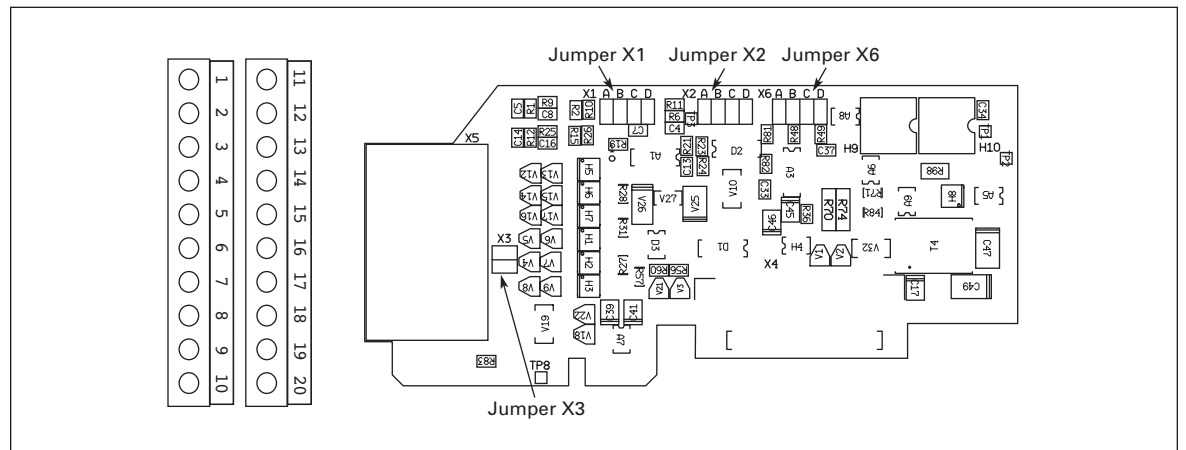
**Table 3-14: Option Board A8 Terminal Descriptions**

Terminal	Signal (Keypad Parameter Reference)	Description and Parameter Reference
1	+10V <sub>ref</sub>	Reference voltage Maximum current 10 mA; Decoupled from the 9000X Series Drive GND
2	AI1+	Analog input, voltage (An.IN:A.1) Default: 0 – +10V (R <sub>i</sub> = 200 kΩ); (-10V to +10V joystick control) 0 – 20 mA (R <sub>i</sub> = 250Ω) Select V or mA with jumper block X1 (Figure 3-24) Resolution 0.1%; Accuracy ±1%
3	AI1- (GND ISOL)	Analog input common GND ISOL/Voltage input; Connected to GND ISOL (selected with jumper)
4	AI2+	Analog input (An.IN:A.2) Default: 0 – 20 mA (R <sub>i</sub> = 250Ω) 0 – +10V (R <sub>i</sub> = 200 kΩ); (-10V to +10V joystick control) Select V or mA with jumper block X2 (Figure 3-24) Resolution 0.1%; Accuracy ±1%
5	AI2- (GND ISOL)	Analog input common GND ISOL/Voltage input; Connected to GND ISOL (selected with jumper)
6	24V <sub>out</sub>	24V control voltage (bi-directional) ±15%, 250 mA (all boards total); 150 mA (max. current from single board); short circuit protected; Can be used as external power backup for the control (and fieldbus); Galvanically connected to terminal #12; Ext +24V DC supply can connect here
7	GND	I/O ground Ground for reference and controls; Galvanically connected to terminal #13
8	DIN1	Digital input 1 (Dig.IN:A.1) R <sub>i</sub> = min. 5 kΩ
9	DIN2	Digital input 2 (Dig.IN:A.2) R <sub>i</sub> = min. 5 kΩ
10	DIN3	Digital input 3 (Dig.IN:A.3) R <sub>i</sub> = min. 5 kΩ
11	CMA	Digital input common A for DIN1, DIN2 and DIN3 Must be connected to GND or 24V of I/O terminals or external 24V or GND. Selection with jumper block X3. (Figure 3-24). Default connected to GND.
12	24V <sub>out</sub>	24V control voltage (bi-directional) Same as terminal #6; Galvanically connected to terminal #6
13	GND	I/O ground Same as terminal #7; Galvanically connected to terminals #7
14	DIN4	Digital input 4 (Dig.IN:A.4) R <sub>i</sub> = min. 5 kΩ
15	DIN5	Digital input 5 (Dig.IN:A.5) R <sub>i</sub> = min. 5 kΩ
16	DIN6	Digital input 6 (Dig.IN:A.6) R <sub>i</sub> = min. 5 kΩ
17	CMB	Digital input common B for DIN4, DIN5 and DIN6 Must be connected to GND or 24V of I/O terminals or external 24V or GND. Selection with jumper block X3. (Figure 3-24). Default connected to GND.
18	A01+	Analog signal (+output) (An.OUT:A.1) Output signal range: Current: 0(4) – 20 mA, R <sub>L</sub> max. 500Ω or Voltage: 0 – 10V, R <sub>L</sub> >1 kΩ – default Selection with jumper block X6. (Figure 3-24) Resolution: 0.1% (10 bits); Accuracy ±2%
19	A01-	Analog output common
20	DO1	Digital output 1 (Dig.OUT:A.1) Open collector, maximum current = 50 mA, maximum voltage = 48V DC

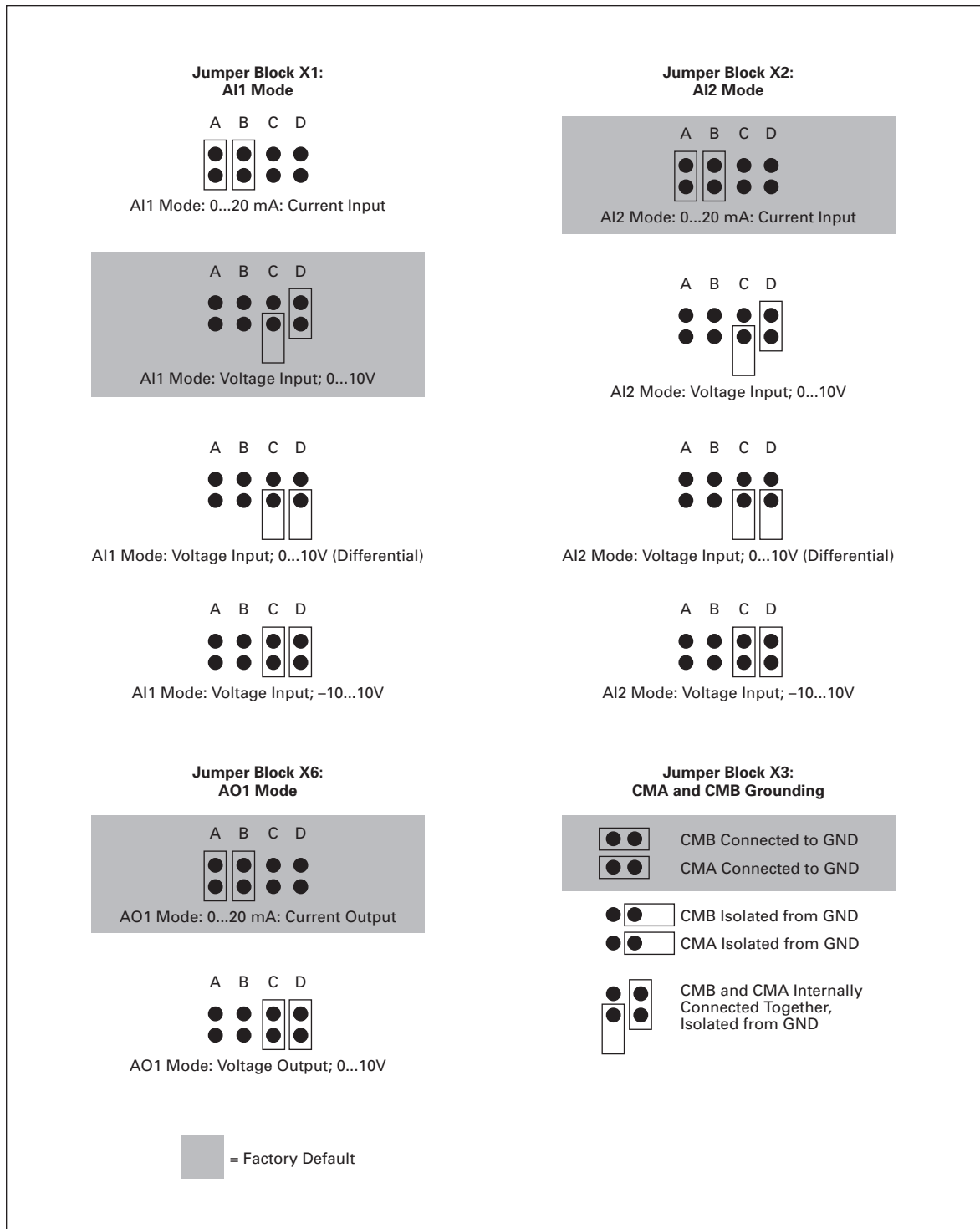
October 2005

**Table 3-15: Option Board A8 Parameters**

Number	Parameter	Min.	Max.	Default	Note
1	AI1 mode	1	5	3	1 = 0 – 20 mA 2 = 4 – 20 mA 3 = 0 – 10V 4 = 2 – 10V 5 = -10 – +10V
2	AI2 mode	1	5	1	1 = 0 – 20 mA 2 = 4 – 20 mA 3 = 0 – 10V 4 = 2 – 10V 5 = -10 – +10V
3	AO1 mode	1	4	1	1 = 0 – 20 mA 2 = 4 – 20 mA 3 = 0 – 10V 4 = 2 – 10V



**Figure 3-23: Option Board A8 Terminal Locations**



**Figure 3-24: Option Board A8 Jumper Locations and Settings**



October 2005

## Option Board A9

### OPTA9

**Description:** Basic I/O board similar to the OPTA1 except that the I/O terminals are larger for Size 14 wires using M3 screws.

**Allowed slots:** A

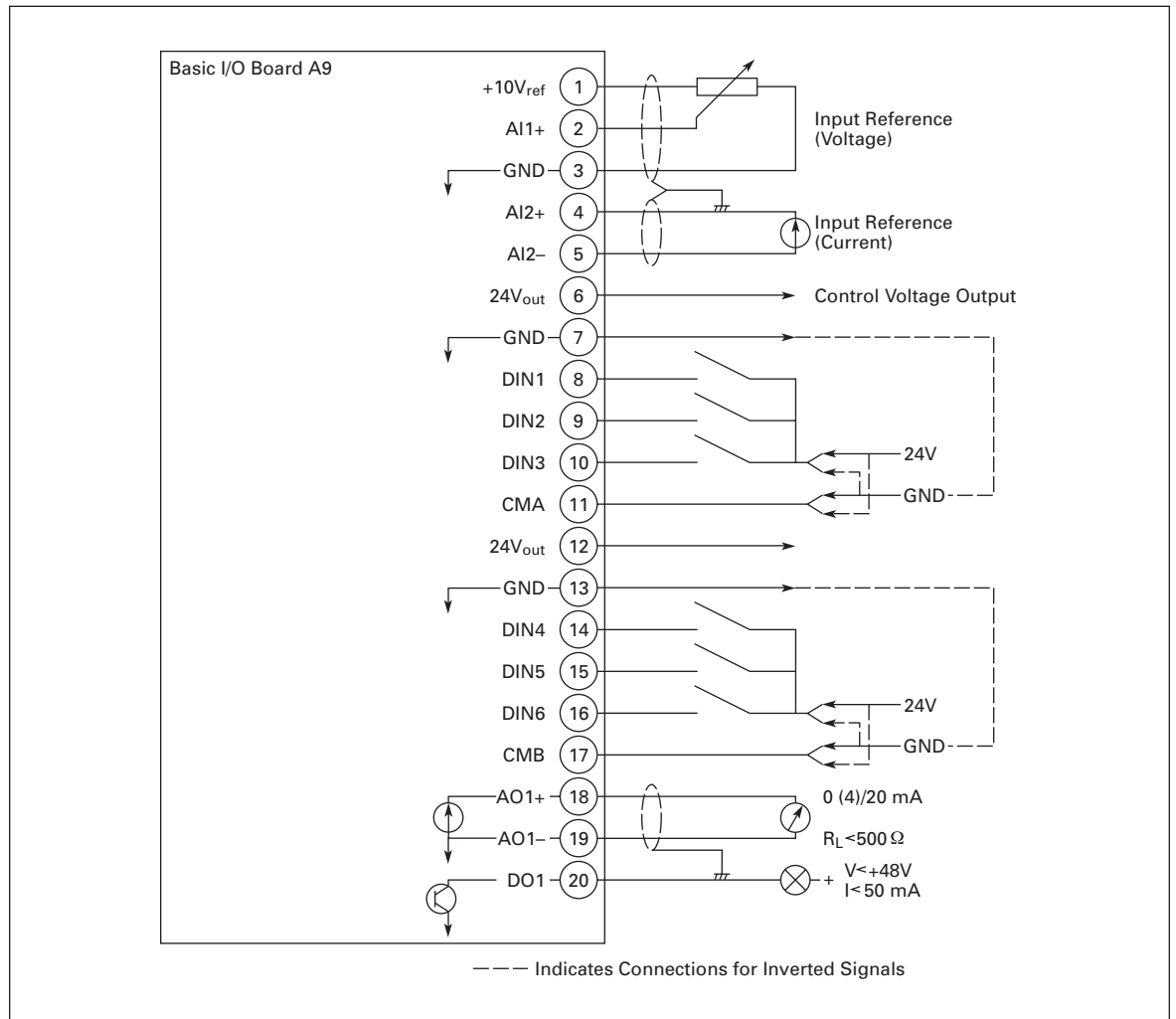
**Type ID:** 16697

**Terminals:** Two terminal blocks; Screw terminals (M3) (see **Figure 3-26**)

**Keying:** Terminals #1 and #12

**Jumpers:** 4; X1, X2, X3 and X6 (see **Figure 3-27**)

**Board parameters:** Yes (see **Table 3-17**)



**Figure 3-25: Option Board A9 Wiring Diagram**

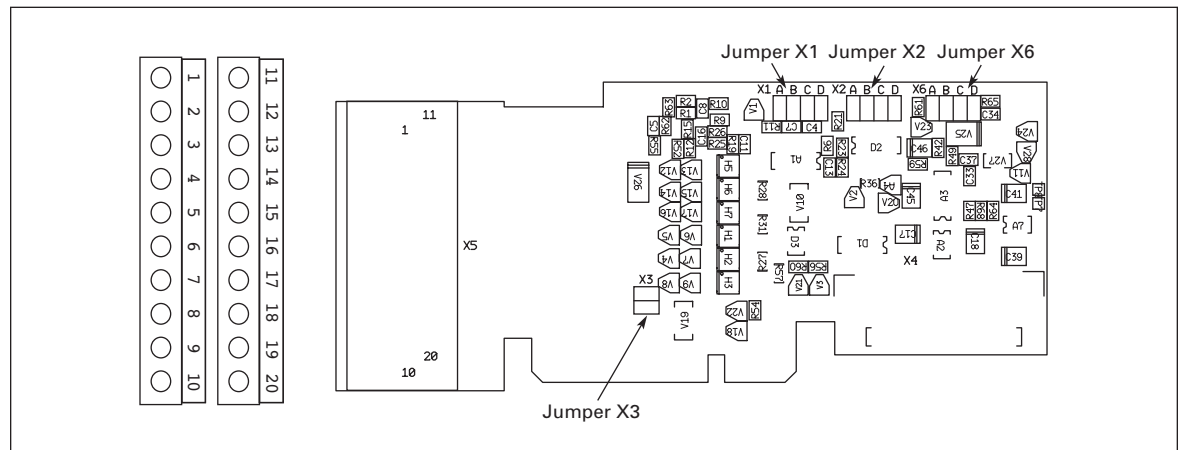
**Table 3-16: Option Board A9 Terminal Descriptions**

Terminal	Signal (Keypad Parameter Reference)	Description and Parameter Reference
1	+10V <sub>ref</sub>	Reference voltage Maximum current 10 mA
2	AI1+	Analog input, voltage (An.IN:A.1) Default: 0 – +10V (R <sub>i</sub> = 200 kΩ); (-10V to +10V joystick control) 0 – 20 mA (R <sub>i</sub> = 250Ω) Select V or mA with jumper block X1 ( <b>Figure 3-27</b> ) Resolution 0.1%; Accuracy ±1%
3	GND	Analog input common Differential input if not connected to ground allows ±20V differential mode voltage to GND
4	AI2+	Analog input (An.IN:A.2) Default: 0 – 20 mA (R <sub>i</sub> = 250Ω) 0 – +10V (R <sub>i</sub> = 200 kΩ); (-10V to +10V joystick control) Select V or mA with jumper block X2 ( <b>Figure 3-27</b> ) Resolution 0.1%; Accuracy ±1%
5	GND/ AI2-	Analog input common Differential input if not connected to ground; allows ±20V differential mode voltage to GND
6	24V <sub>out</sub>	24V control voltage (bi-directional) ±15%, 250 mA (all boards total); 150 mA (max. current from single board); short circuit protected; Can be used as external power backup for the control (and fieldbus); Galvanically connected to terminal #12
7	GND	I/O ground Ground for reference and controls; Galvanically connected to terminals #13, 19
8	DIN1	Digital input 1 (Dig.IN:A.1) R <sub>i</sub> = min. 5 kΩ
9	DIN2	Digital input 2 (Dig.IN:A.2) R <sub>i</sub> = min. 5 kΩ
10	DIN3	Digital input 3 (Dig.IN:A.3) R <sub>i</sub> = min. 5 kΩ
11	CMA	Digital input common A for DIN1, DIN2 and DIN3 Must be connected to GND or 24V of I/O terminal or to external 24V or GND. Default connect to GND. Select with jumper block X3. ( <b>Figure 3-27</b> )
12	24V <sub>out</sub>	24V control voltage (bi-directional) Same as terminal #6; Galvanically connected to terminal #6
13	GND	I/O ground Same as terminal #7; Galvanically connected to terminals #7 & 19
14	DIN4	Digital input 4 (Dig.IN:A.4) R <sub>i</sub> = min. 5 kΩ
15	DIN5	Digital input 5 (Dig.IN:A.5) R <sub>i</sub> = min. 5 kΩ
16	DIN6	Digital input 6 (Dig.IN:A.6) R <sub>i</sub> = min. 5 kΩ
17	CMB	Digital input common B for DIN4, DIN5 and DIN6 Must be connected to GND or 24V of I/O terminal or external 24V or GND. Default connect to GND. Select with jumper block X3. ( <b>Figure 3-27</b> )
18	A01+	Analog signal (+output) (An.OUT:A.1) Output signal range: Current: 0(4) – 20 mA, R <sub>L</sub> max. 500Ω or Voltage: 0 – 10V, R <sub>L</sub> >1 kΩ – default Selection with jumper block X6. ( <b>Figure 3-27</b> ) Resolution: 0.1% (10 bits); Accuracy ±2%
19	A01-	Analog output common Galvanically connected to terminals #7, 13
20	DO1	Digital output 1 (Dig.OUT:A.1) Open collector, maximum current = 50 mA, maximum voltage = 48V DC

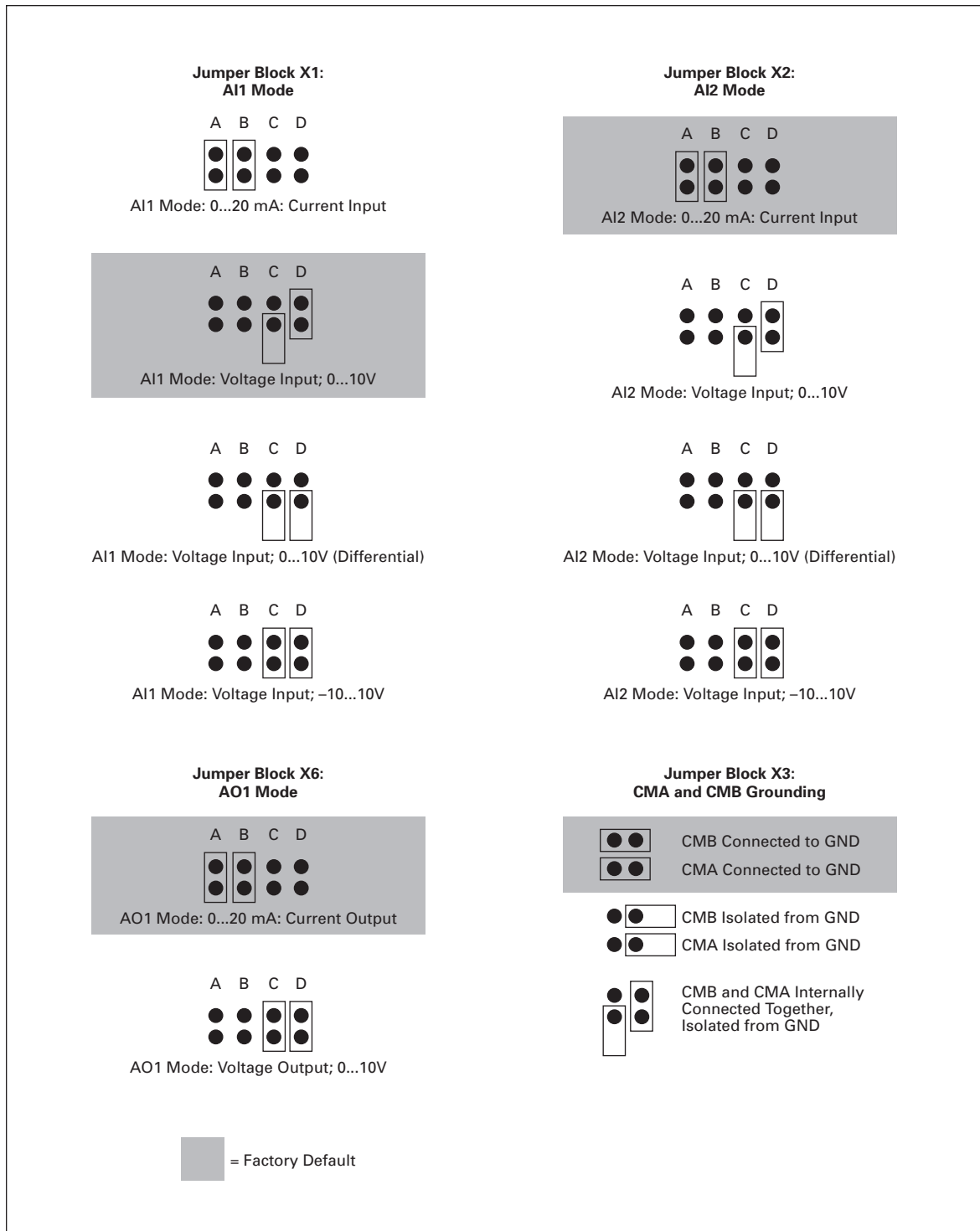
October 2005

**Table 3-17: Option Board A9 Parameters**

Number	Parameter	Min.	Max.	Default	Note
1	AI1 mode	1	5	3	1 = 0 – 20 mA 2 = 4 – 20 mA 3 = 0 – 10V 4 = 2 – 10V 5 = -10 – +10V
2	AI2 mode	1	5	1	1 = 0 – 20 mA 2 = 4 – 20 mA 3 = 0 – 10V 4 = 2 – 10V 5 = -10 – +10V
3	AO1 mode	1	4	1	1 = 0 – 20 mA 2 = 4 – 20 mA 3 = 0 – 10V 4 = 2 – 10V



**Figure 3-26: Option Board A9 Terminal Locations**



**Figure 3-27: Option Board A9 Jumper Locations and Settings**

October 2005

## Option Board AE

### OPTAE

**Description:** Encoder input board with programmable control voltage for an encoder.

The OPTAE board is designed for HTL (High voltage Transistor Logic) type encoders (voltage output type push-pull HTL, open collector output type HTL) which provide input signal levels dependent on the supply voltage of the encoder. The encoder inputs A, B and Z are galvanically isolated.

In addition, the board includes an Encoder Direction Signal and an Encoder Pulse Output Signal. The Encoder Direction Signal value "1" indicates a backward motor direction and "0" indicates a forward motor direction. The Encoder Pulse Output signal is produced from the Encoder input signals (channel A) divided by the divider parameter (see **Page 3-29**).

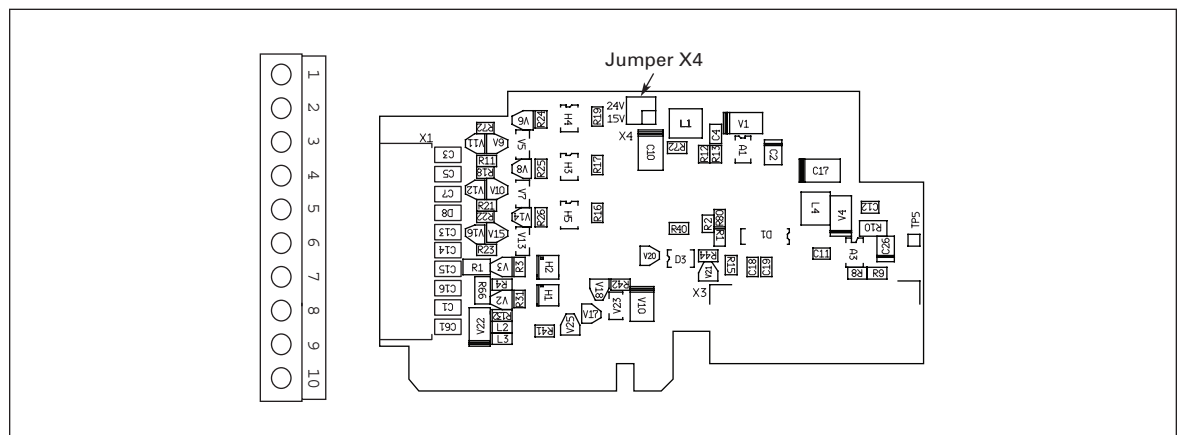
**Allowed slots:** C

**Type ID:** 16709

**Terminals:** One terminal block; Screw terminals (M2.6); Coding in terminal #3

**Jumpers:** 1; X4 (see **Page 3-29**)

**Board parameters:** Yes



**Figure 3-28: Option Board AE Terminal Locations**

**Table 3-18: Option Board AE Terminal Descriptions**

Terminal	Description and Parameter Reference
1	DIC1A+
2	DIC1A-
3	DIC2B+
4	DIC2B-
5	DIC3Z+
6	DIC3Z-
7	DO1
8	DO2
9	GND
10	+15V/+24V

**Note:** Encoder inputs are wide range inputs that can be used with encoders using +15V or +24V.

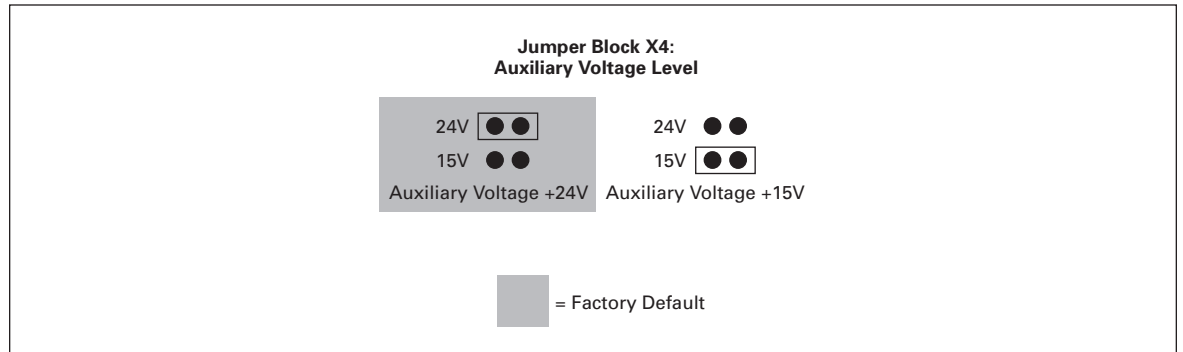
**Table 3-19: Option Board AE Technical Data**

Function	Technical Information
Encoder control voltage, +15V/+24V	Control voltage selectable with jumper X4.
Encoder input connections, inputs A+, A-, B+, B-, Z+, Z-	Max. input frequency $\leq 150$ kHz Inputs A, B and Z are differential
Encoder divider output DO1 Encoder direction output DO2	Max. load voltage       60V DC Max. load current       50 mA Max. output frequency $\leq 300$ kHz

October 2005

**Jumper Selections**

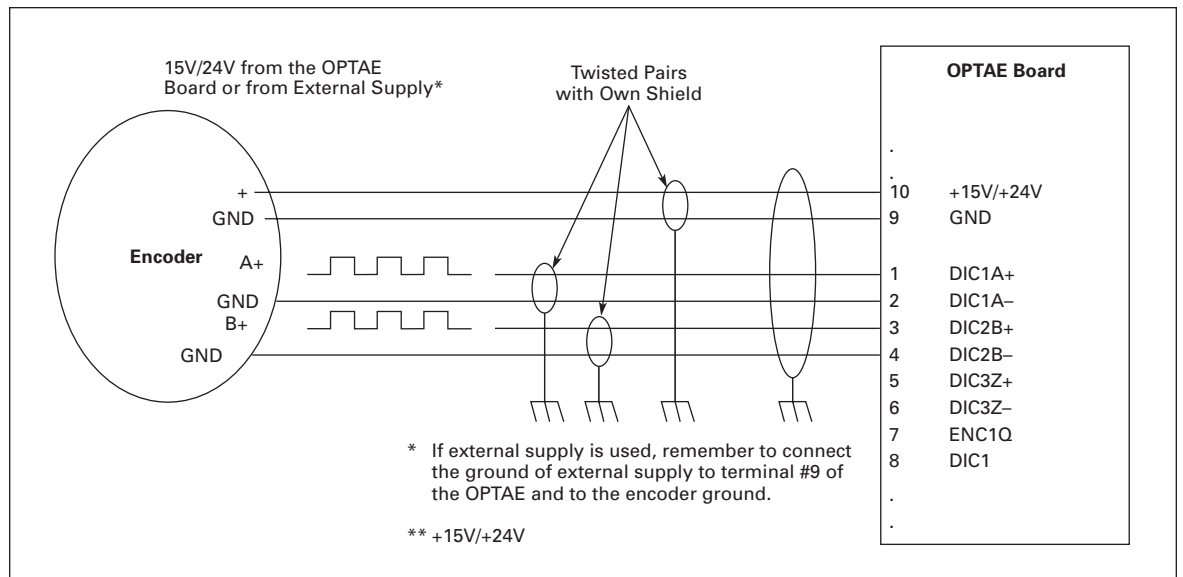
On the OPTAE board, there is one jumper block used to program the control voltage (auxiliary voltage). The factory default and other available jumper selections are presented below.



**Figure 3-29: Jumper Positions for Option Board AE**

**Usage:** Closed Loop Vector Control. The OPTAE board is mainly used in conventional industrial applications where encoder cable lengths are relatively long.

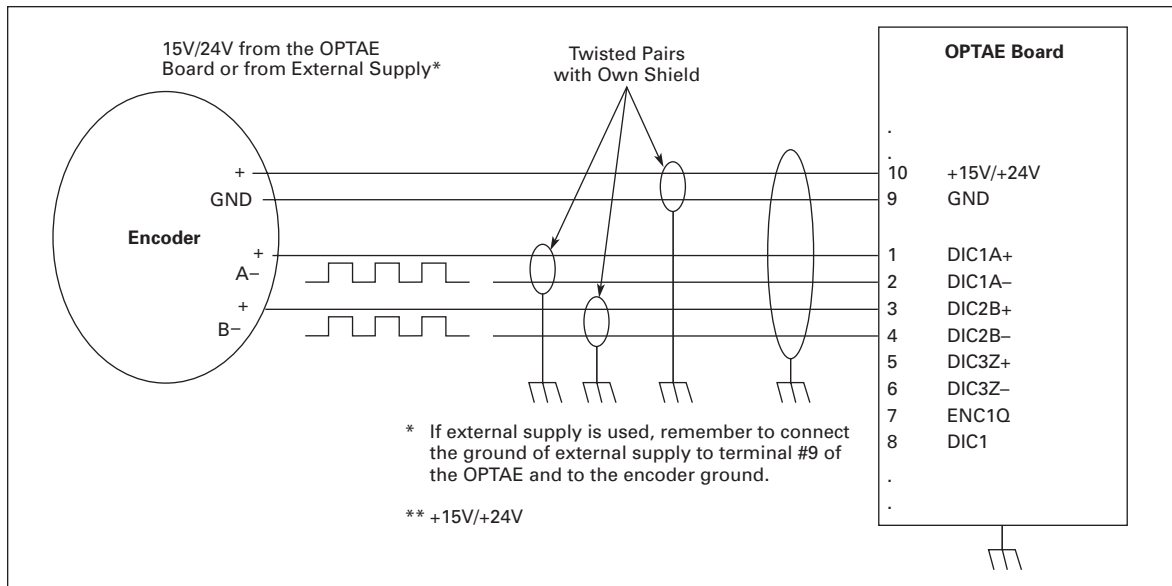
**Encoder Connection — Single-Ended**



**Figure 3-30: HTL Type Encoder Connection (Open Source) Using Single-Ended Inputs**

**Note:** Grounding is to be connected only at the drive to avoid circulating current in the shield. Isolate shield at the encoder.

Double shielded cable is recommended for encoder connection.

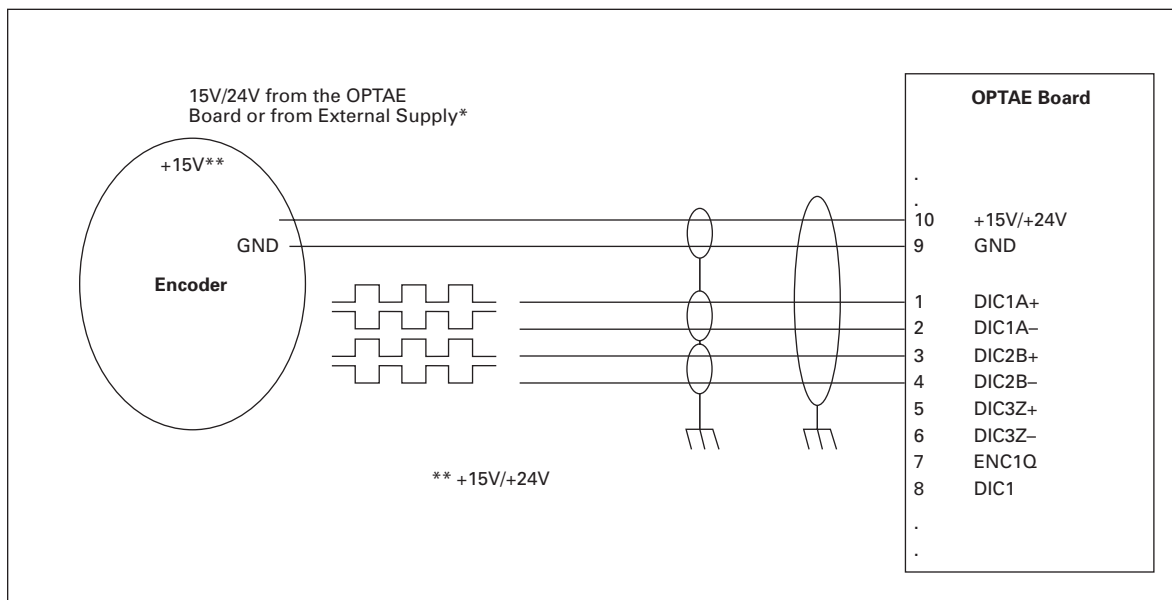


**Figure 3-31: HTL Type Encoder Connection (Open Collector) Using Single-Ended Inputs**

**Note:** Grounding is to be connected only at the drive to avoid circulating current in the shield. Isolate shield at the encoder.

Double shielded cable is recommended for encoder connection.

**Encoder Connection — Differential**



**Figure 3-32: HTL Type Encoder Connection Using Differential Inputs**



October 2005

**Table 3-20: Option Board AE Parameters**

Number	Parameter	Min.	Max.	Default	Note
7.3.1.1	Pulse/ Revolution	1	65535	1024	
7.3.1.2	Invert Direction	0	1	0	<b>0</b> = No <b>1</b> = Yes
7.3.1.3	Reading Rate	0	4	1	Time used to calculate speed actual value. <b>Note:</b> Use value 1 in Closed Loop mode. <b>0</b> = No calculation <b>1</b> = 1 mS <b>2</b> = 5 mS <b>3</b> = 10 mS <b>4</b> = 50 mS
7.3.1.4	Divider Value	1	2048	64	Input pulses/ Divider = Divider Output
7.3.1.5	Hysteresis for Direction Out	0	511	8	Number of pulses before direction signal change state



October 2005

## Chapter 4 — OPTB\_ Option Boards

OPTB\_ option boards are installed in slots B, C, D or E. These boards are used to increase the number of control inputs and outputs. These boards may not be installed in slot A.

There are no board-related parameters for OPTB\_ I/O expander boards, except for board OPTBB.

**Table 4-1: OPTB\_ Board Features**

I/O Board	Allowed Slots	Digital Input (DI)	Digital Output (DO)	Analog Input (AI)	Analog Output (AO)	Relay Output (RO)	Thermistor Input		42 – 240V AC Input	Other
							(TI)	(PT-100)		
OPTB1	B, C, D, E	6 <sup>①</sup>	6 <sup>①</sup>							
OPTB2	B, C, D, E					2	1			
OPTB4	B, C, D, E			1 (Isolated mA)	2 (Isolated mA)					+24V/ EXT+24V
OPTB5	B, C, D, E					3				
OPTB8	B, C, D, E							3		
OPTB9	B, C, D, E					1			5	
OPTBB	C	2 encoder								

<sup>①</sup> 6 total selectable as an input or output.

### Option Board B1

#### *OPTB1*

**Description:** I/O board with six bidirectional terminals, jumper selectable as either digital inputs or digital outputs.

**Allowed slots:** B, C, D, E

**Type ID:** 16945

**Terminals:** One terminal block; Screw terminals (M2.6) (see **Figure 4-1**)

**Keying:** None

**Jumpers:** 2; X2 and X4 (see **Figure 4-2**)

**Board parameters:** None

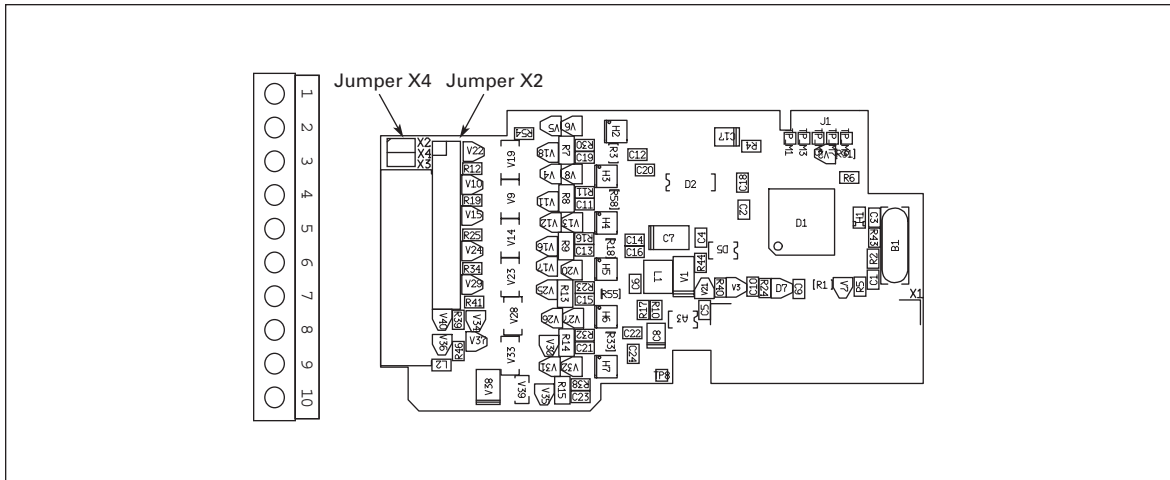


Figure 4-1: Option Board B1 Terminal Locations

Table 4-2: OPTB1 I/O Terminals

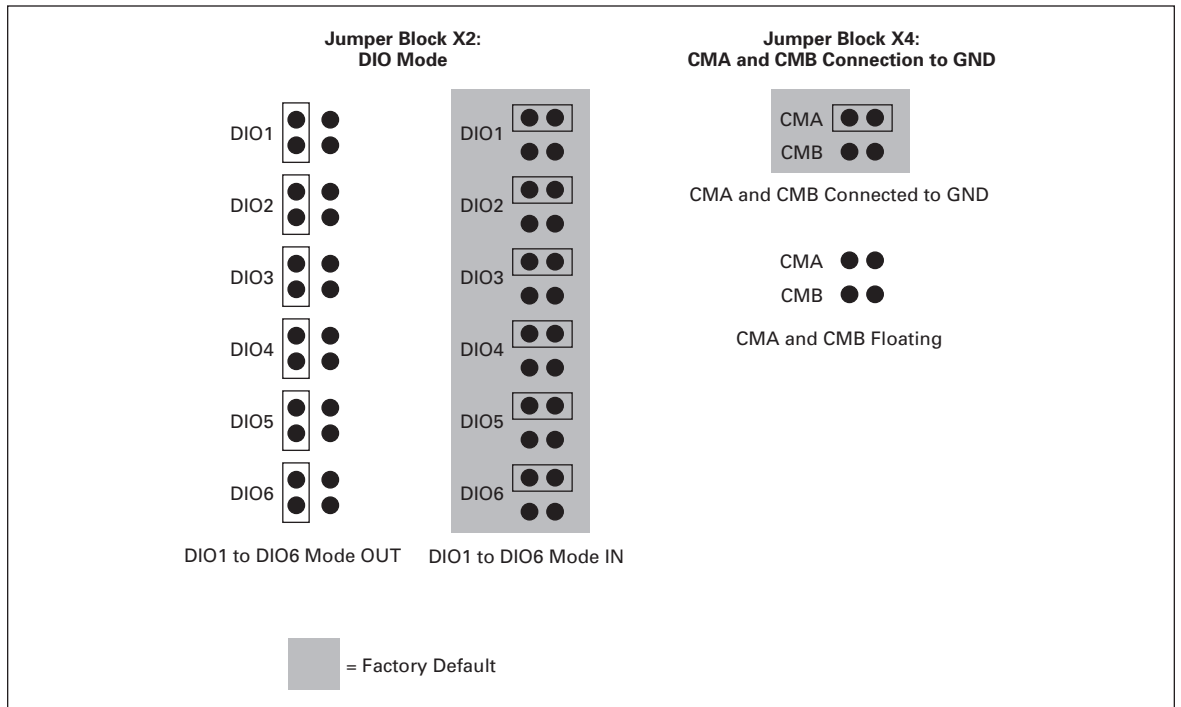
Terminal	Function	Keypad Parameter Reference	Technical Information
1	DIO1	DigIN: X.1 DigOUT: X.1	Digital input: 24V; R <sub>i</sub> > 5 kΩ Digital output: Open collector, <50 mA/48V
2	DIO2	DigIN: X.2 DigOUT: X.2	
3	DIO3	DigIN: X.3 DigOUT: X.3	
4	CMA		Common for DIO1 – DIO3. <b>Note:</b> CMA is internally connected to GND with a jumper by default.
5	DIO4	DigIN: X.4 DigOUT: X.4	Digital input: 24V; R <sub>i</sub> > 5 kΩ Digital output: Open collector, <50 mA/48V
6	DIO5	DigIN: X.5 DigOUT: X.5	
7	DIO6	DigIN: X.6 DigOUT: X.6	
8	CMB		Common for DIO4 – DIO6. <b>Note:</b> CMA is internally connected to GND with a jumper by default.
9	GND		I/O ground; Ground for reference and controls
10	+24V		Control voltage output; Voltage for switches etc.; max. current 150 mA; Short circuit protected.

**Note:** This board can be installed in four different slots. The “X”: in the Keypad Parameter Reference shall be replaced by the slot letter (B, C, D, or E) of the slot in which it is installed. See “Defining Functions to Inputs and Outputs” on **Page 1-7**.

October 2005

**Jumper Selections**

There are two jumper blocks on the OPTB1 board. Jumper block **X2** is used to define the bidirectional terminal as either an input or an output. Jumper block **X4** is used to connect the common terminals CMA and CMB to GND. The factory default and the available jumper selections are illustrated in **Figure 4-2**.



**Figure 4-2: Jumper Positions for OPTB1**

**Option Board B2**

**OPTB2**

**Description:** I/O expander board with a thermistor input and two relay outputs.

**Allowed slots:** B, C, D, E

**Type ID:** 16946

**Terminals:** Three terminal blocks; Screw terminals (M3) (see **Figure 4-4**)

**Keying:** None

**Jumpers:** None

**Board parameters:** None

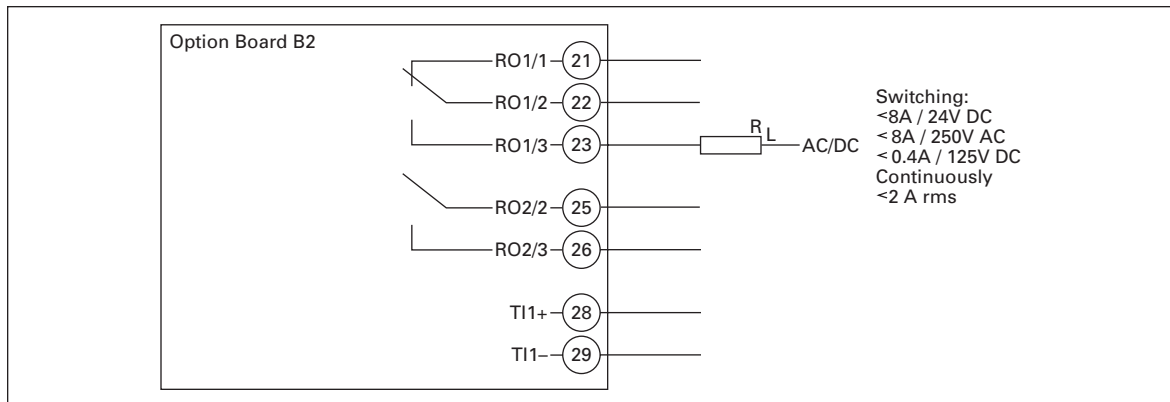


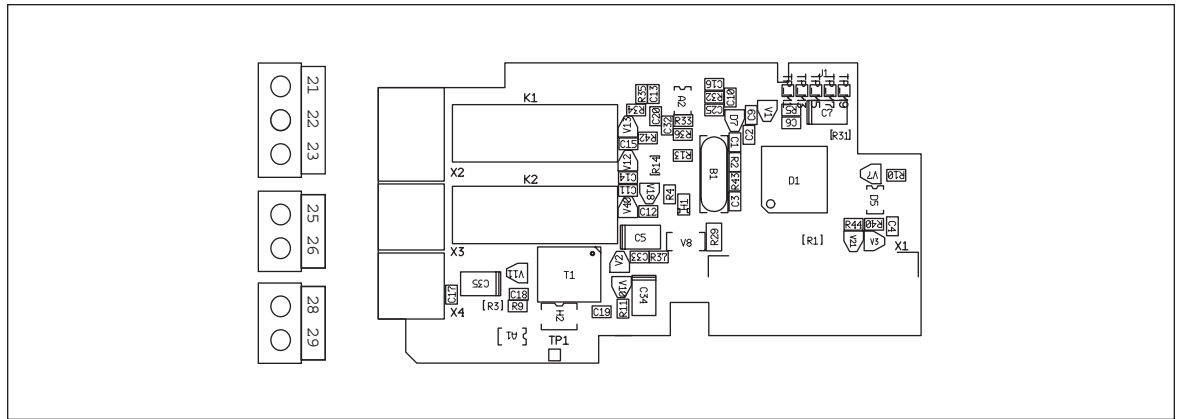
Figure 4-3: Option Board B2 Wiring Diagram

Table 4-3: Option Board B2 Terminal Descriptions

Terminal	Function	Keypad Parameter Reference	Technical Information
21	RO1/1 Normally Closed (NC)	DigOUT: X.1	Switching capacity: 24V DC/8A 250V AC/8A 125V DC/0.4A Min. switching load: 5V/10 mA Continuous capacity: < 2A rms
22	RO1/2 Common		
23	RO1/3 Normally Open (NO)		
25	RO2/2 Common	DigOUT: X.2	Switching capacity: 24V DC/8A 250V AC/8A 125V DC/0.4A Min. switching load: 5V/10 mA Continuous capacity: < 2A rms
26	RO2/3 Normally Open (NO)		
28	TI1+	DigIN: X.1	Thermistor input; $R_{trip} = 4.7 \text{ k}\Omega$ (PTC)
29	TI1-		

**Note:** This board can be installed in four different slots. The “X” in the Keypad Parameter Reference shall be replaced by the slot letter (B, C, D, or E) of the slot in which it is installed. See “Defining Functions to Inputs and Outputs” on **Page 1-7**.

October 2005



**Figure 4-4: Option Board B2 Terminal Locations**

**Option Board B4**

**OPTB4**

**Description:** I/O expander board with one *galvanically* isolated analog input and two *galvanically* isolated analog outputs (standard signals are 0(4)...20 mA).

**Allowed slots:** B, C, D, E

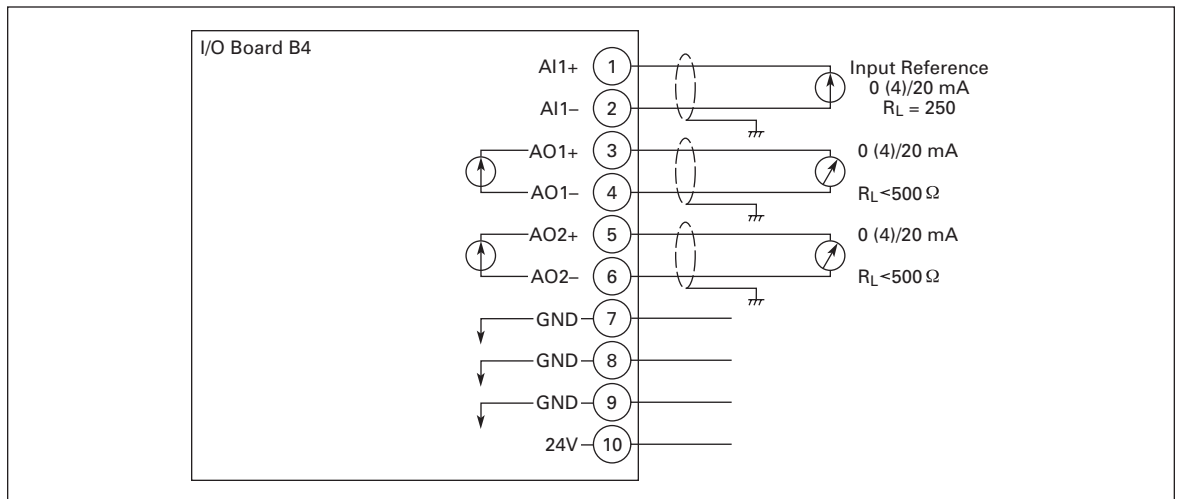
**Type ID:** 16948

**Terminals:** One terminal block; Screw terminals (M2.6) (see **Figure 4-6**)

**Keying:** None

**Jumpers:** None

**Board parameters:** None

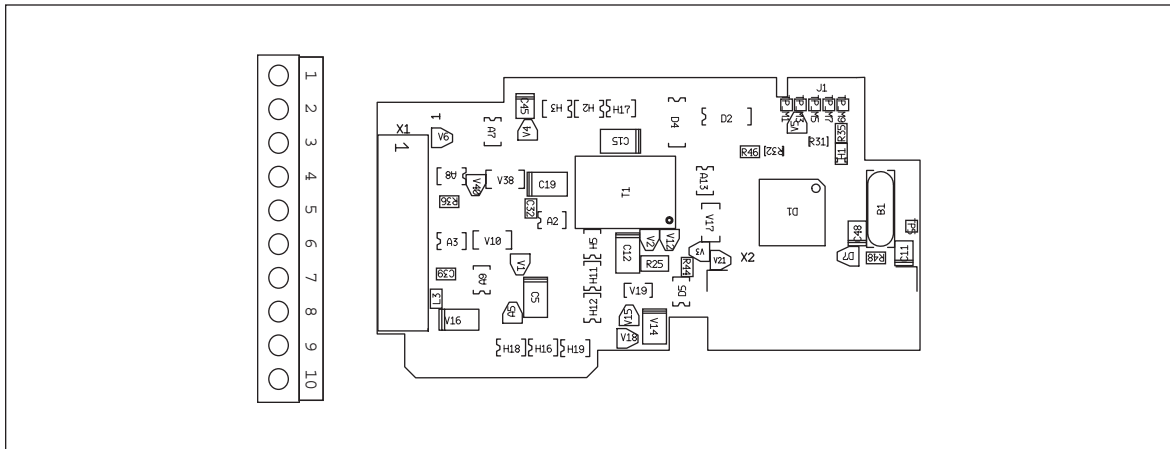


**Figure 4-5: Option Board B4 Wiring Diagram**

**Table 4-4: Option Board B4 I/O Terminals**

Terminal	Function	Keypad Parameter Reference	Technical Information
1	AI1+	AnIN: X.1	0(4) —20 mA; $R_i = 250\Omega$ ; galvanically isolated Resolution 10 bits/0.1%; Accuracy $\pm 1\%$ of the full display
2	AI1-		
3	AO1+	AnOUT: X.1	0(4) —20 mA; $R_L < 500\Omega$ ; Resolution 10 bits/0.1%; Accuracy $\leq \pm 2\%$ (galvanically isolated)
4	AO1-		
5	AO2+	AnOUT: X.2	0(4) —20 mA; $R_L < 500\Omega$ ; Resolution 10 bits/0.1%; Accuracy $\leq \pm 2\%$ (galvanically isolated)  24V ( $\pm 15\%$ ); Max. load 250 mA (total load from EXT+24V outputs), max. 150 mA from one board. See <b>Figure 1-2</b> on <b>Page 1-4</b> .  In special applications where PLC type functions are included in the control module, this output can be used as an external auxiliary power supply for control boards and I/O boards.
6	AO2-		
7	GND		
8	GND		
9	GND		
10	+24V		

**Note:** This board can be installed in four different slots. The “X” in the Keypad Parameter Reference shall be replaced by the slot letter (B, C, D, or E) of the slot in which it is installed. See “Defining Functions to Inputs and Outputs” on **Page 1-7**.



**Figure 4-6: Option Board B4 Terminal Locations**



October 2005

## Option Board B5

### OPTB5

**Description:** Relay board with three relay outputs.

**Allowed slots:** B, C, D, E

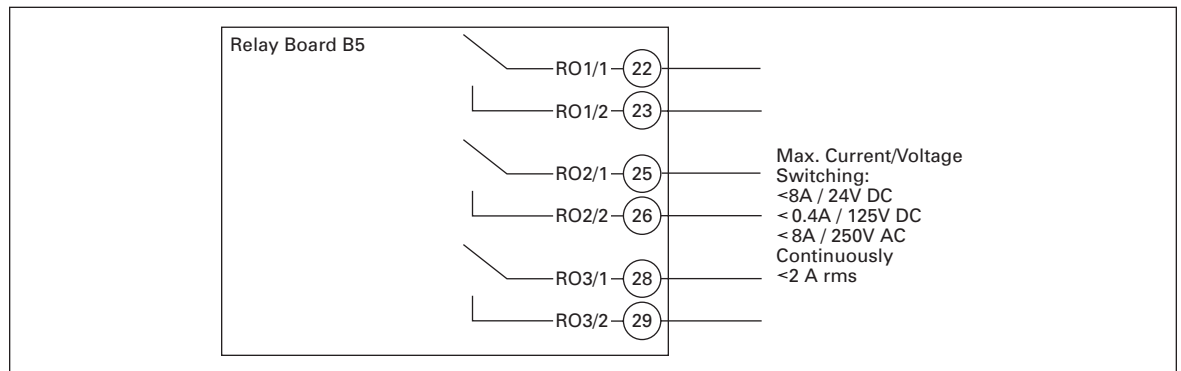
**Type ID:** 16949

**Terminals:** Three terminal blocks; Screw terminals (M3) (see **Figure 4-8**)

**Keying:** None

**Jumpers:** None

**Board parameters:** None



**Figure 4-7: Option Board B5 Wiring Diagram**

**Table 4-5: Option Board B5 I/O Terminals**

Terminal	Signal	Keypad Parameter Reference	Technical Information
22	RO1/1	Common	Switching capacity: 24V DC/8A 250V AC/8A 125V DC/0.4A Min. switching load: 5V/10 mA Continuous capacity: < 2A rms
23	RO1/2	Normally Open	
25	RO2/1	Common	
26	RO2/2	Normally Open	
28	RO3/1	Common	
29	RO3/2	Normally Open	

**Note:** This board can be installed in four different slots. The "X" in the Keypad Parameter Reference shall be replaced by the slot letter (B, C, D, or E) of the slot in which it is installed. See "Defining Functions to Inputs and Outputs" on **Page 1-7**.

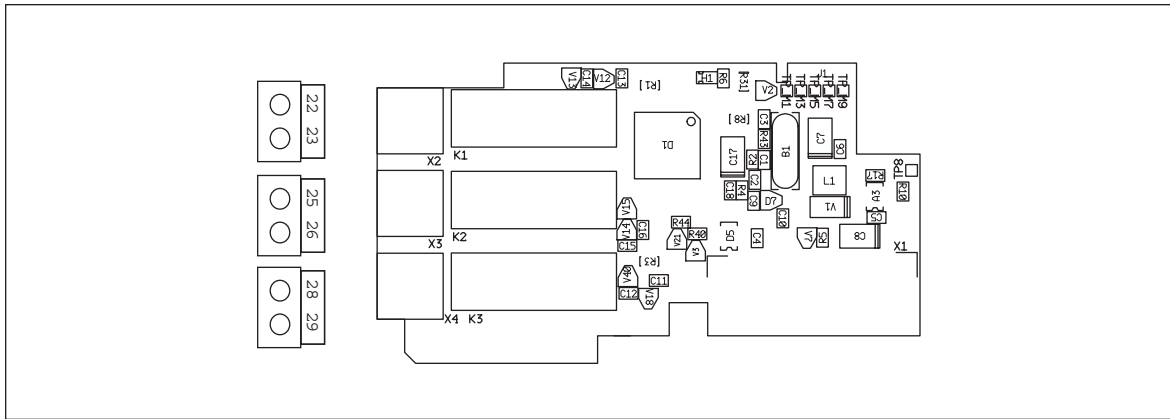


Figure 4-8: Option Board B5 Terminal Locations

## Option Board B8

### OPTB8

**Description:** Temperature measuring board with three PT-100 sensor (3-wire) inputs. The measurable temperature range is -22 – 392°F (-30 – 200°C). Both 3-wire and 2-wire elements can be used.

**Allowed slots:** B, C, D, E

**Type ID:** 16952

**Terminals:** One terminal block; Screw terminals (M2.6) (see Figure 4-11)

**Keying:** None

**Jumpers:** 1; X2 (see Figure 4-10)

**Board parameters:** None

Table 4-6: Option Board B8 I/O Terminals

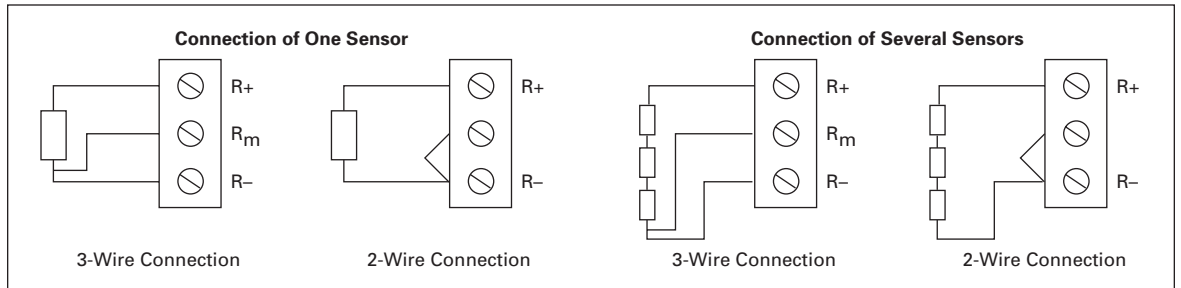
Terminal	Function	Keypad Parameter Reference	Technical Information
1	R1 +	AnIN: X1	PT-100 Input, -30 — 200°C, one sensor. Accuracy $\leq 1$ °C. Sensor current 10 mA
2	R <sub>m</sub> 1		
3	R1 –		
4	R2 +	AnIN: X2	PT-100 Input, -30 — 200°C, one sensor. Accuracy $\leq 1$ °C. Sensor current 10 mA
5	R <sub>m</sub> 2		
6	R2 –		
7	R3 +	AnIN: X3	PT-100 Input, -30 — 200°C, 1 — 3 sensors (see X2 jumper selections). Accuracy $\leq 1$ °C. Sensor current 10 mA
8	R <sub>m</sub> 3		
9	R3 –		
10			Not connected

**Note:** This board can be installed in four different slots. The “X” in the Keypad Parameter Reference shall be replaced by the slot letter (B, C, D, or E) of the slot in which it is installed. See “Defining Functions to Inputs and Outputs” on Page 1-7. Insulation level 4 kV/ $\sqrt{2}$  (DIN VDE 01 10-1). 2 kV in sensor and 2k V in option board.

October 2005

**Connection of PT-100 sensors**

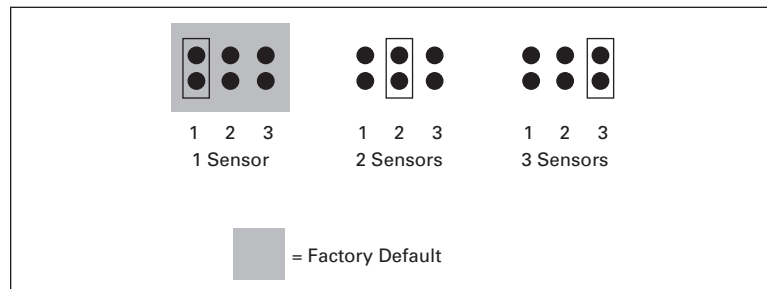
One PT-100 sensor can be connected to each of the first two inputs (terminals 1 to 3 and 4 to 6) and up to three sensors to the third input (terminals 7 to 9). The sensors must be connected in *series* with a two- or three-wire connection.



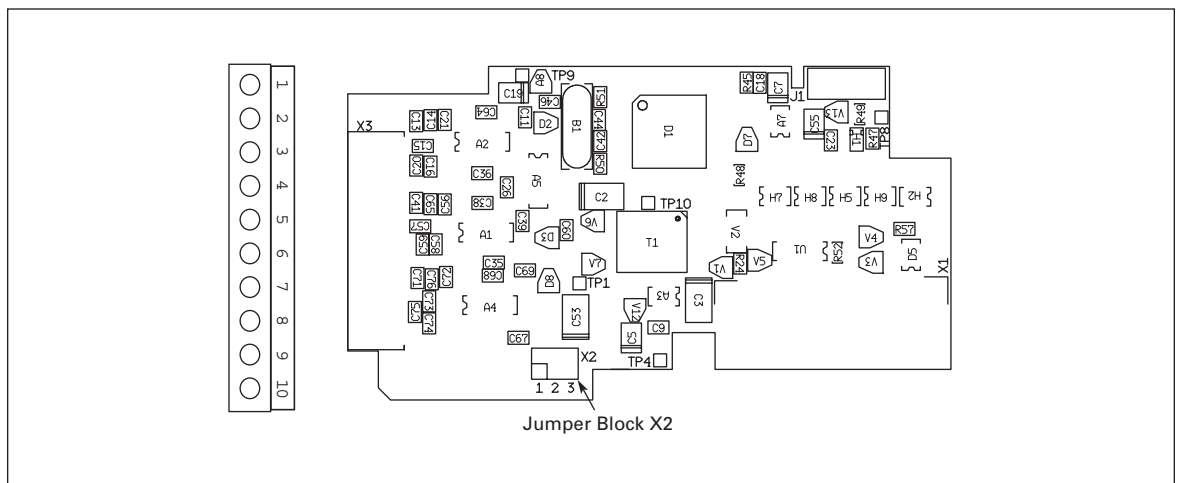
**Figure 4-9: Option Board B8 PT-100 Connections**

**Jumper Selections**

Up to three PT-100 sensors can be connected to the third PT-100 input. Select the number of sensors in use with jumper block X2:



**Figure 4-10: Option Board B8 Jumper Selections**



**Figure 4-11: Option Board B8 Terminal Locations**

## Option Board B9

### OPTB9

**Description:** I/O board with five 42 – 240V AC digital inputs and one relay output.

**Allowed slots:** B, C, D, E

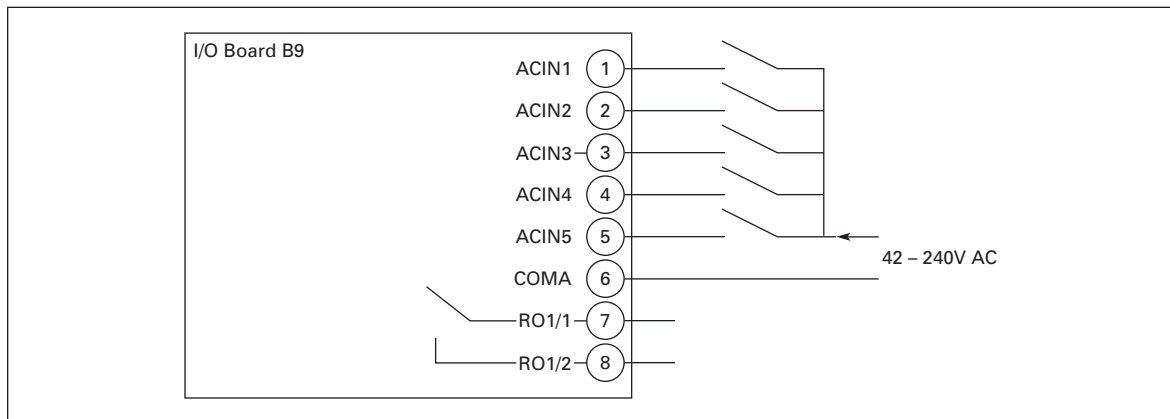
**Type ID:** 16953

**Terminals:** One terminal block; Screw terminals (M2.6) (see **Figure 4-13**)

**Keying:** None

**Jumpers:** None

**Board parameters:** None



**Figure 4-12: Option Board B9 Wiring Diagram**

**Table 4-7: Option Board B9 I/O Terminals**

Terminal	Function	Keypad Parameter Reference	Technical Information
1	ACIN1	DigIN: X1	Digital input, 42 – 240V AC (threshold 35V) Control voltage: "0"<33V, "1">35V
2	ACIN2	DigIN: X2	Digital input, 42 – 240V AC (threshold 35V) Control voltage: "0"<33V, "1">35V
3	ACIN3	DigIN: X3	Digital input, 42 – 240V AC (threshold 35V) Control voltage: "0"<33V, "1">35V
4	ACIN4	DigIN: X4	Digital input, 42 – 240V AC (threshold 35V) Control voltage: "0"<33V, "1">35V
5	ACIN5	DigIN: X5	Digital input, 42 – 240V AC (threshold 35V) Control voltage: "0"<33V, "1">35V
6	COMA		Digital input X1, X2, X3, X4, X5 common
7	RO1 Common	DigOUT: X1	Switching capacity: 24V DC/8A 250V AC/8A 125V DC/0.4A Min. switching load: 5V/10 mA Continuous capacity: < 2A rms
8	RO1 Normally Open		

**Note:** This board can be installed in four different slots. The "X" in the Keypad Parameter Reference shall be replaced by the slot letter (B, C, D, or E) of the slot in which it is installed. See "Defining Functions to Inputs and Outputs" on **Page 1-7**.

October 2005

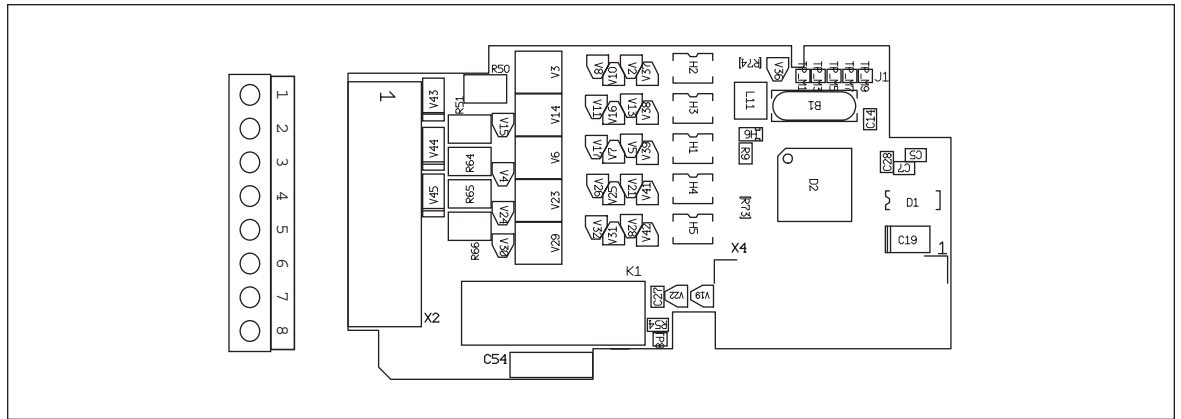


Figure 4-13: Option Board B9 Terminal Locations

## Option Board BB

### OPTBB

**Description:** Absolute encoder board with inputs for an ENDAT type encoder, programmable control voltage, fast digital inputs and simulation pulse output.

The output pulse is produced from sinusoidal input signals.

The galvanically isolated fast digital inputs are used to trace very short pulses.

**Allowed slots:** C

**Type ID:** 16962 – Main board

16963 – Secondary board mounted on the main board

**Terminals:** Two terminal blocks; Screw terminals (M2.6) (see **Figure 4-15**)

**Keying:** None

**Jumpers:** 1; X11 (see **Figure 4-14**)

**Board parameters:** Yes (see **Table 4-11**)

An *absolute encoder* is a type of encoder capable of specifying its absolute position. The position data is retained even during a power failure or breakdown. The position data carried by the absolute encoder can be used by the 9000X Series Drive for the control of a synchronous motor.

**Table 4-8: Encoder Properties**

Property	Technical Information
Encoder cable	Maximum length 330 feet (100 meters) — type equivalent to Heidenhain cable
Encoder voltage	5V, 12V, 15V Maximum current consumption 300 mA
Measuring steps per revolution	4.2 billion (maximum 32 bit)
Distinguishable revolutions	0 – 65535 (maximum 16 bit)
Signal periods per revolution	1 – 65535

ENDAT is a bi-directional synchronic serial interface for absolute encoders. For example, the encoder position data can be read and encoder parameters can be set via the ENDAT connection. It also forwards the messages related to the encoder functions. All ENDAT connections are made on terminal block X6. This board uses ENDAT version 2.

**Table 4-9: I/O Terminals on Option Board BB, Terminal Block X6**

Terminal		Heidenhain Color Code	Technical Data
1	DATA +	Gray	Data line 120 $\Omega$ /RS-485
2	DATA –	Pink	
3	CLOCK +	Violet	Clock line 120 $\Omega$ /RS-485 (200 — 400 kHz)
4	CLOCK –	Yellow	
5	A +	Green/black	1Vpp ( $\pm 0.5$ V); impedance 120 $\Omega$ ; max. input 350 kHz
6	A –	Yellow/black	
7	B +	Blue/black	1Vpp ( $\pm 0.5$ V); impedance 120 $\Omega$ ; max. input 350 kHz
8	B –	Red/black	
9	GND	White/green	Input ground
10	Encoder voltage	Brown/green	Selectable encoder voltage: 5V, 12V and 15V Maximum current consumption 300 mA

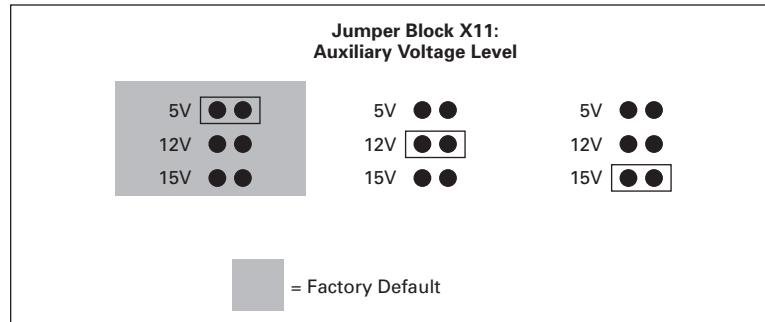
**Table 4-10: I/O Terminals on Option Board BB, Terminal Block X7**

Terminal		Technical Data
1	SimA+	Incremental pulse output A (differential), 0° (square wave, signal level RS-422); Impedance 120 $\Omega$ ; Input hysteresis –5 mV
2	SimA–	
3	SimB+	Incremental pulse output B (differential), 0° (square wave, signal level RS-422); Impedance 120 $\Omega$ ; Input hysteresis –5 mV
4	SimB–	
5	Not used	
6	Not used	
7	FDIN1	Fast digital input 1; HTL; Minimum pulse length 50 $\mu$ S
8	CMA	Common FDIN1
9	FDIN2	Fast digital input 2; HTL; Minimum pulse length 50 $\mu$ S
10	CMB	Common FDIN2

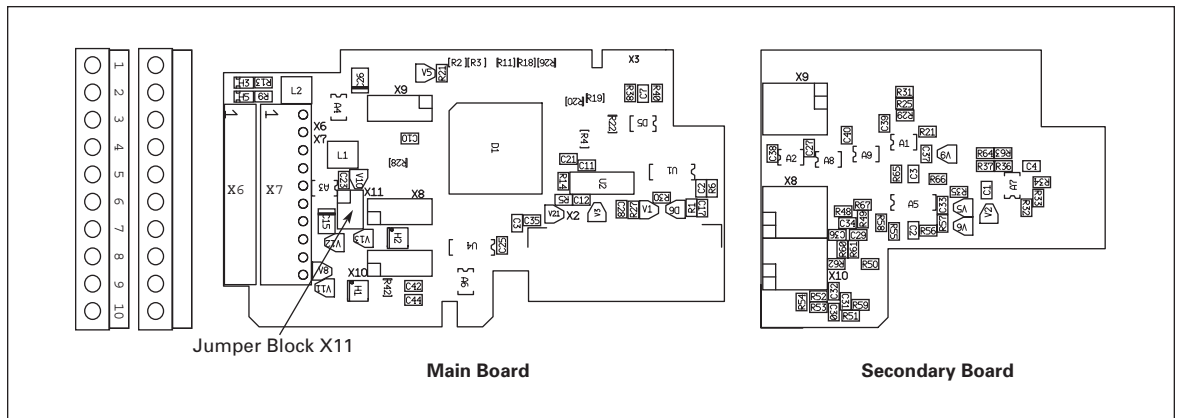
October 2005

**Jumper Selections**

The OPTBB board has one jumper block which is used to program the control voltage (auxiliary voltage). The factory default and the other jumper selections are shown in Figure 4-14.



**Figure 4-14: Option Board BB Jumper Selections**



**Figure 4-15: Option Board BB Terminal Locations**

**Table 4-11: Option Board BB Parameters**

Parameter		Min.	Max.	Default	Selections	Description
Code ①	Name					
7.3.1.1	Reverse	0	1	0	0=No 1=Yes	Manually selectable rotation direction
7.3.1.2	Reading rate	0	4	1	0=Not used 1=1 mS 2=5 mS 3=10 mS 4=50 mS	Incremental pulse reading rate. <b>Note:</b> Use value 1 in Closed Loop mode.
7.3.1.3	Interpolation	0	1	0	0=No 1=Yes	If activated, the sinusoidal incremental pulses are used to calculate the polar angle in order to optimize the encoder accuracy

① This is an example of Code for these parameters. The actual value of Code is application dependent.

**Table 4-12: Option Board BB Monitored Values**

Parameter		Unit	Description
Code <sup>①</sup>	Monitored value		
7.3.2.1	Reverse	Hz	Motor speed in Hz calculated from encoder pulses
7.3.2.2	Encoder speed	rpm	Motor speed in rpm calculated from encoder pulses
7.3.2.3	Encoder position		Absolute position of encoder read from ENDAT
7.3.2.4	Encoder revolution		
7.3.2.5	Encoder fault		
7.3.2.6	Encoder warning		
7.3.2.7	Encoder messages		Number of messages between encoder and OPTBB

<sup>①</sup> This is an example of Code for these parameters. The actual value of Code is application dependent.

**Table 4-13: Option Board BB Information Pages**

Parameter		Unit	Description
Code <sup>②</sup>	Information		
7.3.3.1	Encoder type		0 = No encoder connected 1 – 4 = Incremental linear encoder 5 = Linear absolute encoder 6 = Unknown 7 = Linear absolute encoder 8 = Unknown 9 – 12 = Rotational incremental/angular encoder 13 = Absolute encoder (single turn) 14 = Unknown 15 = Absolute encoder (multi turn) 16 = Unknown
7.3.3.2	Pulses/Revolution		Sinusoidal pulses/revolution
7.3.3.3	Position bits	bit	Accurate position 1 – 1024 (10bit = $2^{10}$ = 1024)
7.3.3.4	Revolution bits	bit	Accurate number of revolutions 1 – 1024 (10bit = $2^{10}$ = 1024)

<sup>②</sup> This is an example of Code for these parameters. The actual value of Code is application dependent.

**Table 4-14: Option Board BB LED Status Indicators**

LED	Indication	Meaning
Yellow	OFF	Option board not activated
	ON	Option board in initialization state waiting for activation command from the 9000X Series Drive
	Blinking fast (once/sec)	Option board is activated and in the RUN state indicating that it is ready for external communication
	Blinking slow (once/5 sec)	Option board is activated and in the FAULT state indicating an internal fault of option board
Green	OFF	Option board not activated
	ON	Encoder is being initialized Board is reading encoder parameters
	Blinking fast (once/sec)	Encoder detected by option board Board is receiving data from encoder
	Blinking slow (once/5 sec)	Encoder detected by option board Board cannot read encoder data or data is invalid (CRC error, broken cable, etc.)



October 2005

## Chapter 5 — OPTD\_ Adapter Boards

The OPTD\_ adapter boards do not provide any additional I/O but are used to connect the 9000X Series Drive to a communication bus (System Bus, SPI, CAN). Note that if you use any of the major fieldbuses (Profibus, Modbus, etc.) for communication, you will need a corresponding *fieldbus board*. For more information, see the specific fieldbus board manual.

**Table 5-1: OPTD\_ Board Features**

I/O Board	Allowed Slots	Description
OPTD1	D, E	System Bus adapter board
OPTD2 <sup>①</sup>	(B), D, E	System Bus adapter board with interface to fast monitoring bus
OPTD3	D, E	RS-232 serial interface board

<sup>①</sup> If this board is installed in slot B the System Bus is not available; only the Monitor Bus can be used.

**Note:** Do not plug two system bus adapter boards into the same control board in order to avoid compatibility problems.

### Option Board D1

#### OPTD1

**Description:** System Bus adapter board

**Allowed slots:** D, E

**Type ID:** 17457

**Terminals:** Double optical input and output terminals (see **Figure 5-1**)

**Keying:** None

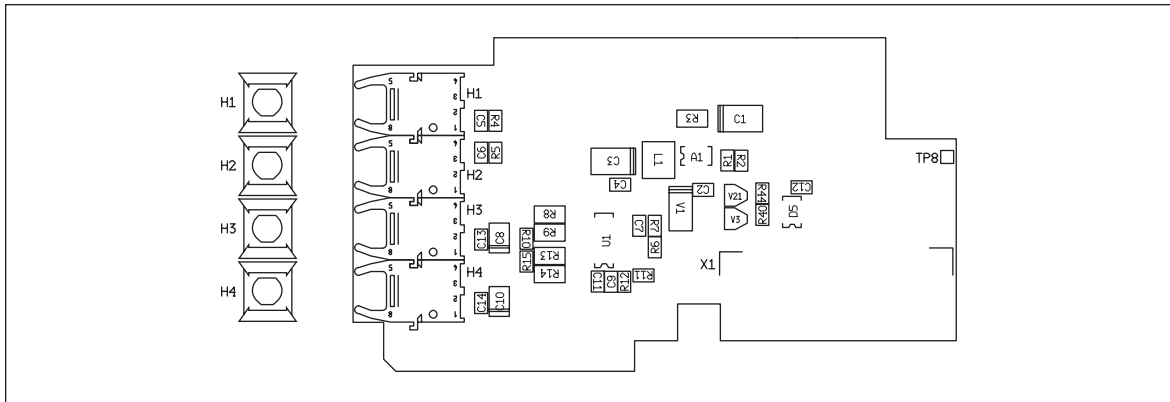
**Jumpers:** None

**Board parameters:** None

**Table 5-2: Option Board D1 I/O Terminals**

Terminal	Technical Data
1	H1 System Bus optical input 1 (RX1) Use 1-mm optical cable (e.g. Agilent HFBR-RUS500)
2	H2 System Bus optical input 2 (RX2) Use 1-mm optical cable (e.g. Agilent HFBR-RUS500)
3	H3 System Bus optical output 1 (TX1) Use 1-mm optical cable (e.g. Agilent HFBR-RUS500)
4	H4 System Bus optical output 2 (TX2) Use 1-mm optical cable (e.g. Agilent HFBR-RUS500)

**Note:** When shipped, these board terminals are protected with a rubber pin. Make sure that the pin remains inserted in any unused terminals to prevent misoperation.



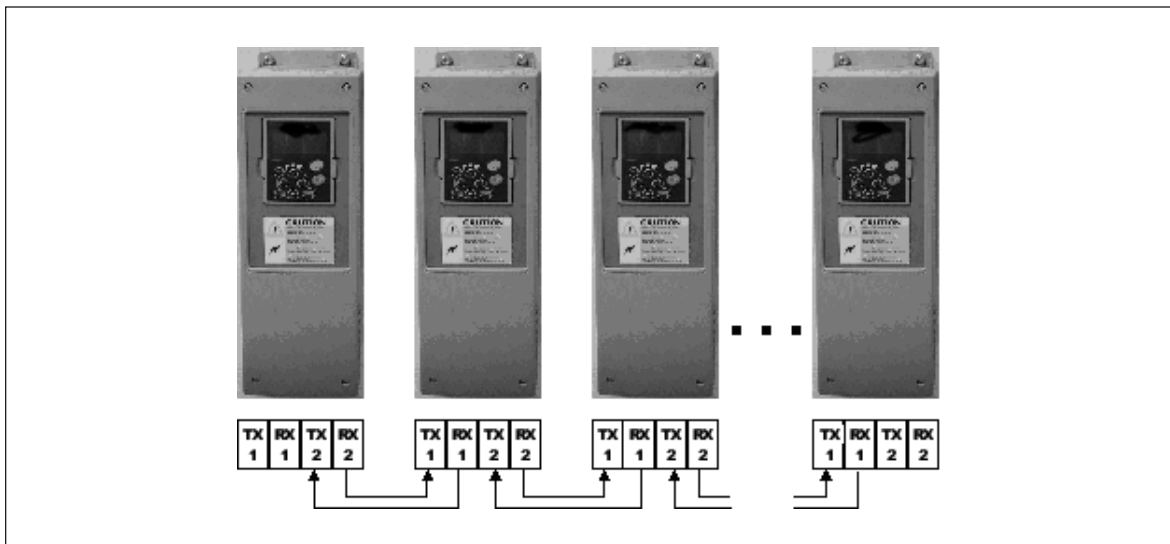
**Figure 5-1: Option Board D1 Terminal Locations**

**Basic Connection between 9000X Series Drives with the D1 Option Board**

Connect the output 1 of Device 1 to the input 2 of Device 2 and the input of Device 1 to the output 2 of Device 2. Note that in the end devices one terminal pair remains unused. See **Figure 5-2** for an example.

**Table 5-3: Option Board D1 Device Count vs. Speed**

Maximum number of devices in line	Maximum speed achieved (Mbit/sec)
3	12
6	6
12	3
24	1.5



**Figure 5-2: Basic Connection Between Drives with D1 Option Board**

October 2005

## Option Board D2

### OPTD2

**Description:** System Bus adapter board for 9000X Series Drives with single optical input and output; Interface to fast monitor bus used by the NCSYSDRIVE PC software tool.

**Allowed slots:** (B), D, E; **Note:** If only the Monitor Bus (terminals 21 to 23) will be used, this board can also be installed in slot B. The System Bus is then unavailable. In this situation remove jumpers X5 and X6.

**Type ID:** 17458

**Terminals:** Single optical input and output; one screw (M3) terminal block (see **Figure 5-3**)

**Keying:** None

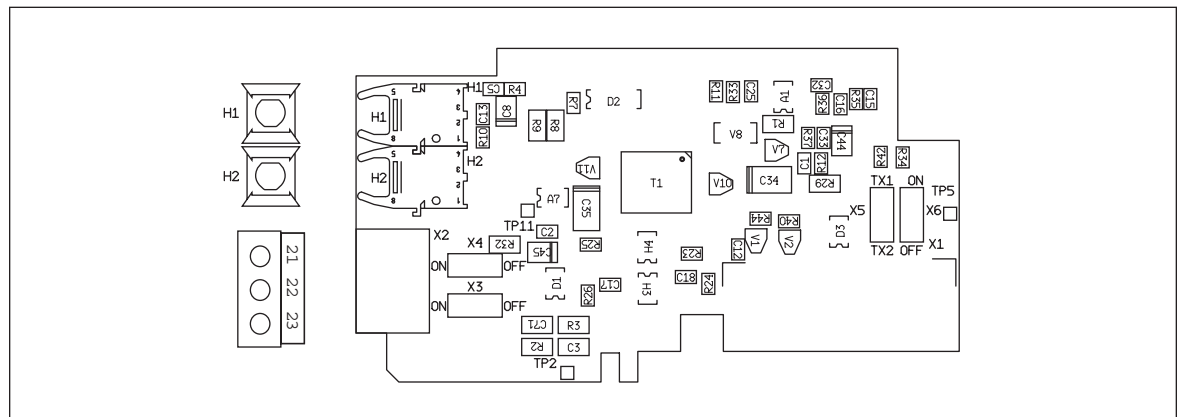
**Jumpers:** 4; X3, X4, X5 and X6 (see **Figure 5-4**)

**Board parameters:** None

**Table 5-4: Option Board D2 I/O Terminals**

Terminal		Technical Data
1	H1	System Bus optical input 1 (RX1) Use 1-mm optical cable (e.g. Agilent HFBR-RUS500) ①
2	H2	System Bus optical output 1/2 (TX1/TX2); Selected with jumper X5 Use 1-mm optical cable (e.g. Agilent HFBR-RUS500) ①
21	CAN_L	Monitor Bus negative data
22	CAN_H	Monitor Bus positive data
23	CAN_GND	Monitor Bus ground

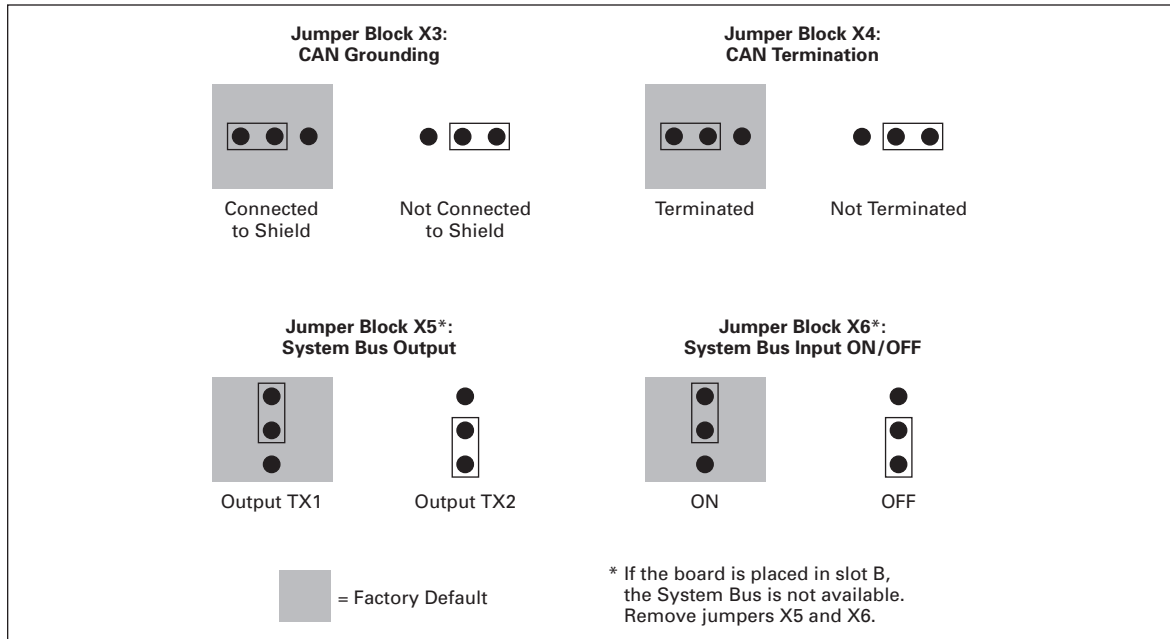
① Not available if this board is installed in slot B.



**Figure 5-3: Option Board D2 Terminal Locations**

**Jumper Selections**

There are four jumper blocks on the OPTD2 board. The factory defaults and the other jumper selections are shown in **Figure 5-4**.



**Figure 5-4: Option Board D2 Jumper Selections**

**Special Connection between 9000X Series Drives with the D2 Option Board**

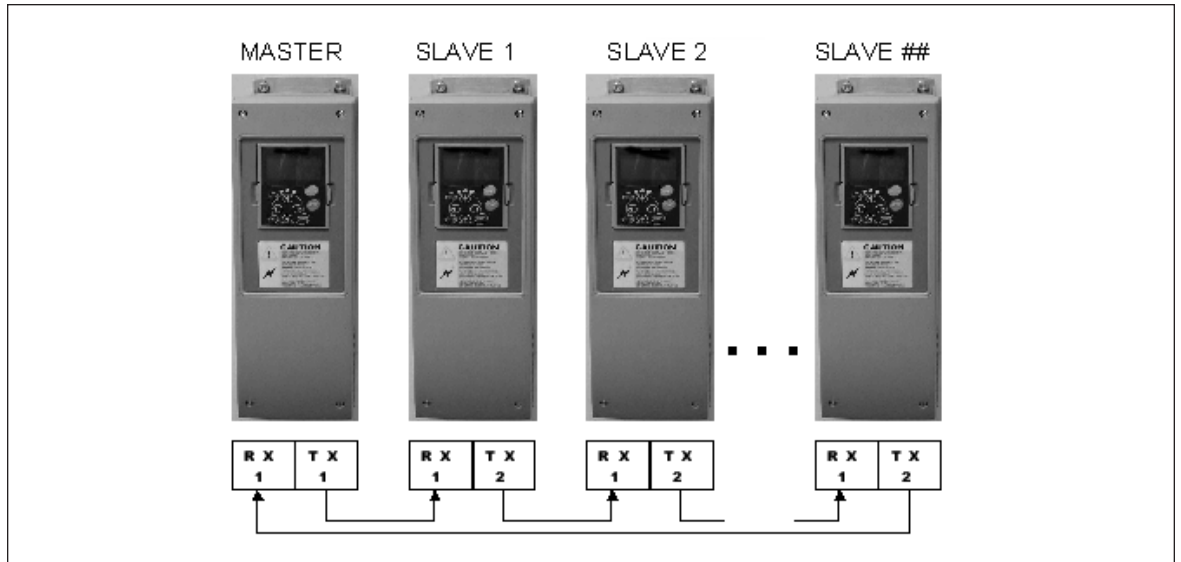
In this connection example, the leftmost device is the Master and the others are slaves. The Master can send and receive data from the slaves. The slaves cannot communicate with each other. Changing the Master is not possible, the first device is always the Master. See **Figure 5-5** for this example.

The OPTD2 board in the Master uses the default jumper selections, i.e. X6: 1-2, X5: 1-2. The jumper positions for the slaves have to be changed from the default value to X6: 1-2, X5: 2-3.

**Table 5-5: Option Board D2 Device Count vs. Speed**

Maximum number of devices in line	Maximum speed achieved (Mbit/sec)
3	12
6	6
12	3
24	1.5

October 2005



**Figure 5-5: Connection Example for Drives with D2 Option Board**

**Option Board D3**

**OPTD3**

**Description:** RS-232 serial interface board. Galvanically decoupled.

**Allowed slots:** D, E

**Type ID:** 17459

**Terminals:** 9 pin female sub-D connector (see **Figure 5-6**)

**Keying:** None

**Jumpers:** 1; X3 (see **Figure 5-7**)

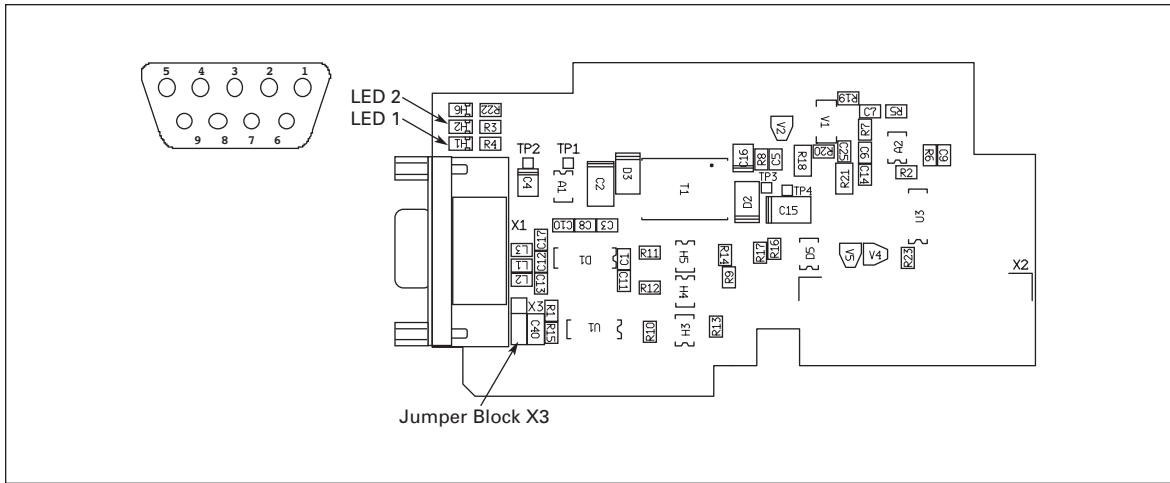
**Board parameters:** None

**D3 Board Function**

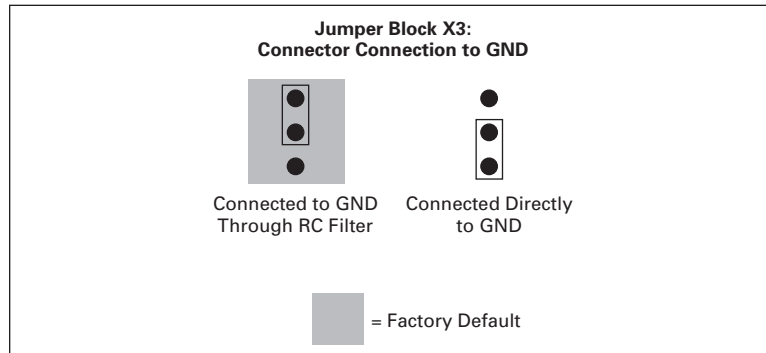
This board provides an alternate RS-232 port for the use of a second keypad or to connect a PC when it is desired to keep the keypad installed in the control panel. The functions available at this port are identical to those available from the control panel RS-232 port.

**Table 5-6: Option Board D3 RS-232 Sub-D Connector Wiring**

Terminal	Technical Data	
1		
2	TxD	Transmit data
3	RxD	Receive data
4		
5	GND	Ground isolated
6	+9V	+9V isolated
7		
8		
9		



**Figure 5-6: Option Board D3 RS-232 Sub-D Connector and LED Location**



**Figure 5-7: Option Board D3 Jumper Selections**

**Table 5-7: Option Board D3 Status LEDs**

LED		Meaning When Lit
Green	LED 1	Receiving data
Red	LED 2	Transmitting data

October 2005

## Chapter 6 — Option Boards — Detail Summary

**Table 6-1: Option Board Summary: 1 of 3**

Board Type	Allowed Slots <sup>①</sup>	ID	Digital Input (DI)	Digital Output (DO)	Analog Input (AI) (mA/V)	Analog Input (AI) (mA), isol.	Analog Output (AO) (mA/V)	Analog Output (AO) (mA), isol.
------------	----------------------------	----	--------------------	---------------------	--------------------------	-------------------------------	---------------------------	--------------------------------

**Basic Boards OPTA\_**

OPTA1	A	16689	6	1	2		1	
OPTA2	B	16690						
OPTA3	B	16691						
OPTA4 <sup>②</sup>	C	16692						
OPTA5 <sup>②</sup>	C	16693						
OPTA7	C	16695		2				
OPTA8	A	16696	6	1	2 <sup>⑤</sup>		1 <sup>⑤</sup>	
OPTA9 <sup>③</sup>	A	16697	6	1	2		1	
OPTAE <sup>②</sup>	A	16709		2				

**I/O Expander Boards OPTB\_**

OPTB1	BCDE	16945	6 <sup>⑥</sup>	6 <sup>⑥</sup>				
OPTB4	BCDE	16948				1 <sup>⑦</sup>		2 <sup>⑦</sup>
OPTB5	BCDE	16949						
OPTB8	BCDE	16952						
OPTB9	BCDE	16953						
OPTBB	C	16962 16963						

**I/O Expander Boards OPTD\_**

OPTD1	<b>DE</b>	17457	System Bus adapter board: 2 x fiber optic pairs					
OPTD2 <sup>④</sup>	(B) <b>DE</b>	17458	System Bus adapter board: 1 x fiber optic pair and CAN bus adapter (galvanically decoupled)					
OPTD3	<b>DE</b>	17459	RS-232 serial interface board (galvanically decoupled)					

- ① If a board can be inserted in more than one option slot, the bold letter indicates the default slot. This is not applicable if several boards are installed which have the same default slot.
- ② A special application is required for use in some 9000X Series Drives.
- ③ Similar to OPTA1 except has larger terminals for 2.5 mm<sup>2</sup> wires.
- ④ If this board is installed in slot B the System Bus is not available; only the Monitor Bus can be used. In this situation, remove jumpers X5 and X6.
- ⑤ Analog inputs AI1 and AI2, analog output AO1 and voltage reference +10V<sub>ref</sub> are galvanically decoupled (all are at the same potential).
- ⑥ Bidirectional terminals which can be either digital inputs or outputs.
- ⑦ Analog input AI1 and analog outputs AO1 and AO2 are galvanically decoupled from each other and the other electronics.

Table 6-2: Option Board Summary: 2 of 3

Board Type	Allowed Slots <sup>①</sup>	ID	Relay Output (no/nc)	Relay Output (no)	+10V <sub>ref</sub>	Thermistor Input (TI)	+24V/EXT+24V	42 – 240V AC
------------	----------------------------	----	----------------------	-------------------	---------------------	-----------------------	--------------	--------------

**Basic Boards OPTA\_**

OPTA1	A	16689			1		2	
OPTA2	B	16690	2					
OPTA3	B	16691	1	1		1		
OPTA4 <sup>②</sup>	C	16692						
OPTA5 <sup>②</sup>	C	16693						
OPTA7	C	16695						
OPTA8	A	16696			1 <sup>③</sup>		2	
OPTA9 <sup>③</sup>	A	16697			1		2	
OPTAE <sup>②</sup>	A	16709						

**I/O Expander Boards OPTB\_**

OPTB1	BCDE	16945						
OPTB4	BCDE	16948					1	
OPTB5	BCDE	16949		3				
OPTB8	BCDE	16952						
OPTB9	BCDE	16953		1				5
OPTBB	C	16962 16963						

**I/O Expander Boards OPTD\_**

OPTD1	DE	17457	System Bus adapter board: 2 x fiber optic pairs					
OPTD2 <sup>④</sup>	(B)DE	17458	System Bus adapter board: 1 x fiber optic pair and CAN bus adapter (galvanically decoupled)					
OPTD3	DE	17459	RS-232 serial interface board (galvanically decoupled)					

<sup>①</sup> If a board can be inserted in more than one option slot, the bold letter indicates the default slot. This is not applicable if several boards are installed which have the same default slot.

<sup>②</sup> A special application is required for use in some 9000X Series Drives.

<sup>③</sup> Similar to OPTA1 except has larger terminals for 2.5 mm<sup>2</sup> wires.

<sup>④</sup> If this board is installed in slot B the System Bus is not available; only the Monitor Bus can be used. In this situation, remove jumpers X5 and X6.

<sup>⑤</sup> Analog inputs AI1 and AI2, analog output AO1 and voltage reference +10V<sub>ref</sub> are galvanically decoupled (all are at the same potential).



October 2005

**Table 6-3: Option Board Summary: 3 of 3**

Board Type	Allowed Slots <sup>①</sup>	ID	DI (Enc. 10 – 24V)	DI (Enc. RS-422)	Out + 5V/ +15V/ +24V	Out +15V/ +24V	Out + 5V/ +12V/ +15V	PT-100
------------	----------------------------	----	--------------------	------------------	----------------------------	-------------------	----------------------------	--------

**Basic Boards OPTA\_**

OPTA1	A	16689						
OPTA2	B	16690						
OPTA3	B	16691						
OPTA4 <sup>②</sup>	C	16692		3	1			
OPTA5 <sup>②</sup>	C	16693	3			1		
OPTA7	C	16695	6			1		
OPTA8	A	16696						
OPTA9 <sup>③</sup>	A	16697						
OPTAE <sup>②</sup>	A	16709	3					

**I/O Expander Boards OPTB\_**

OPTB1	BCDE	16945						
OPTB4	BCDE	16948						
OPTB5	BCDE	16949						
OPTB8	BCDE	16952						3
OPTB9	BCDE	16953						
OPTBB	C	16962 16963	2				1	

**I/O Expander Boards OPTD\_**

OPTD1	<b>DE</b>	17457	System Bus adapter board: 2 x fiber optic pairs					
OPTD2 <sup>④</sup>	(B) <b>DE</b>	17458	System Bus adapter board: 1 x fiber optic pair and CAN bus adapter (galvanically decoupled)					
OPTD3	<b>DE</b>	17459	RS-232 serial interface board (galvanically decoupled)					

<sup>①</sup> If a board can be inserted in more than one option slot, the bold letter indicates the default slot. This is not applicable if several boards are installed which have the same default slot.

<sup>②</sup> A special application is required for use in some 9000X Series Drives.

<sup>③</sup> Similar to OPTA1 except has larger terminals for 2.5 mm<sup>2</sup> wires.

<sup>④</sup> If this board is installed in slot B the System Bus is not available; only the Monitor Bus can be used. In this situation, remove jumpers X5 and X6.





## Company Information

Eaton's electrical business is a global leader in electrical control, power distribution, and industrial automation products and services. Through advanced product development, world-class manufacturing methods, and global engineering services and support, Eaton's electrical business provides customer-driven solutions under brand names such as Cutler-Hammer®, Powerware®, Durant®, Heinemann®, Holec® and MEM®, which globally serve the changing needs of the industrial, utility, light commercial, residential, and OEM markets. For more information, visit [www.EatonElectrical.com](http://www.EatonElectrical.com).

Eaton Corporation is a diversified industrial manufacturer with 2004 sales of \$9.8 billion. Eaton is a global leader in electrical systems and components for power quality, distribution and control; fluid power systems and services for industrial, mobile and aircraft equipment; intelligent truck drivetrain systems for safety and fuel economy; and automotive engine air management systems, powertrain solutions and specialty controls for performance, fuel economy and safety. Eaton has 56,000 employees and sells products to customers in more than 125 countries. For more information, visit [www.eaton.com](http://www.eaton.com).

Eaton Electrical Inc.  
1000 Cherrington Parkway  
Moon Township, PA 15108-4312  
USA  
tel: 1-800-525-2000  
[www.EatonElectrical.com](http://www.EatonElectrical.com)

**EAT•N**

**Cutler-Hammer**

© 2005 Eaton Corporation  
All Rights Reserved  
Printed in USA  
Publication No. MN04003001E/CPG  
October 2005