

# Installation manual



## **DISCLAIMER OF WARRANTIES AND LIMITATION OF LIABILITY**

The information, recommendations, descriptions, and safety notations in this document are based on manufacturer's experience and judgment and may not cover all contingencies. If further information is required, a sales representative should be consulted. Sale of the product shown in this literature is subject to the terms and conditions outlined in appropriate manufacturer selling policies or other contractual agreement between manufacturer and the purchaser.

THERE ARE NO UNDERSTANDINGS, AGREEMENTS, WARRANTIES, EXPRESSED OR IMPLIED, INCLUDING WARRANTIES OF FITNESS FOR A PARTICULAR PURPOSE OR MERCHANTABILITY, OTHER THAN THOSE SPECIFICALLY SET OUT IN ANY EXISTING CONTRACT BETWEEN THE PARTIES. ANY SUCH CONTRACT STATES THE ENTIRE OBLIGATION OF THE MANUFACTURER. THE CONTENTS OF THIS DOCUMENT SHALL NOT BECOME PART OF OR MODIFY ANY CONTRACT BETWEEN THE PARTIES.

In no event will the manufacturer be responsible to the purchaser or user in contract, in tort (including negligence), strict liability, or otherwise for any special, indirect, incidental, or consequential damage or loss whatsoever, including but not limited to damage or loss of use of equipment, plant or power system, cost of capital, loss of power, additional expenses in the use of existing power facilities, or claims against the purchaser or user by its customers resulting from the use of the information, recommendations, and descriptions contained herein. The information contained in this manual is subject to change without notice.

Cover Photo: Eaton PowerXL Series Drive

## Support services

### Support services

The goal of Eaton is to ensure your greatest possible satisfaction with the operation of our products.

We are dedicated to providing fast, friendly, and accurate assistance. That is why we offer you so many ways to get the support you need. Whether it is by phone, fax, or email, you can access Eaton's support information 24 hours a day, seven days a week.

Our wide range of services is listed below.

You should contact your local distributor for product pricing, availability, ordering, expediting, and repairs.

### Website

Use the Eaton Website to find product information. You can also find information on local distributors or Eaton's sales offices.

### Website address

[www.eaton.com/drives](http://www.eaton.com/drives)

### EatonCare Customer Support Center

Call the EatonCare Support Center if you need assistance with placing an order, stock availability or proof of shipment, expediting an existing order, emergency shipments, product price information, returns other than warranty returns, and information on local distributors or sales offices.

Voice: 877-ETN-CARE (386-2273) (8:00 a.m.–6:00 p.m. EST)  
After-Hours Emergency: 800-543-7038 (6:00 p.m.–8:00 a.m. EST)

### Drives Technical Resource Center

Voice: 877-ETN-CARE (386-2273) option 2, option 6  
(8:00 a.m.–5:00 p.m. Central Time U.S. [UTC –6])  
email: [TRCDrives@Eaton.com](mailto:TRCDrives@Eaton.com)

### For customers in Europe, contact

Phone: +49 (0) 228 6 02-3640  
Hotline: +49 (0) 180 5 223822  
email: [AfterSalesEGBonn@Eaton.com](mailto:AfterSalesEGBonn@Eaton.com)  
[www.eaton.com/moeller/aftersales](http://www.eaton.com/moeller/aftersales)

## Table of contents

### SAFETY

Before commencing the installation . . . . .	ix
Definitions and symbols . . . . .	x
Hazardous high voltage . . . . .	x
DANGER	
5 MIN . . . . .	x
Warnings and cautions . . . . .	x

### CHAPTER 1—POWERXL SERIES OVERVIEW

How to use this manual . . . . .	1
Receiving and inspection . . . . .	1
Real time clock battery activation . . . . .	1
Rating label . . . . .	2
Carton labels (U.S. and Europe) . . . . .	2
Catalog number system . . . . .	3
Power ratings and product selection . . . . .	4
DG1 replacement parts . . . . .	8
DH1 replacement parts . . . . .	11

### CHAPTER 2—ENGINEERING CONSIDERATIONS

Introduction . . . . .	15
Electrical power network . . . . .	16
Input voltage and frequency . . . . .	16
Input voltage balance . . . . .	16
Total harmonic distortion (THD) . . . . .	17
Reactive power compensation devices . . . . .	17

### CHAPTER 3—PRODUCT OVERVIEW

Component identification . . . . .	18
Selection criteria . . . . .	20
Proper use . . . . .	20
Maintenance and inspection . . . . .	21
Storage . . . . .	21
Service and warranty . . . . .	21

### CHAPTER 4—SAFETY AND SWITCHING

Fuses and cable cross-sections . . . . .	22
Cables and fuses . . . . .	22
Residual-current device (RCD) . . . . .	22
Leakage current . . . . .	23
Input contactor . . . . .	23
EMC Measures . . . . .	24

### CHAPTER 5—MOTOR AND APPLICATION

Motor selection . . . . .	25
Connecting motors in parallel . . . . .	25
Parallel connection of several motors to one frequency inverter . . . . .	26
Bypass operation . . . . .	28
Connecting EX motors . . . . .	28

## Table of contents, continued

### CHAPTER 6—INSTALLATION REQUIREMENTS

Electrical installation warnings and cautions . . . . .	29
Standard mounting instructions . . . . .	29
Dimensions . . . . .	31
Standard drive mounting . . . . .	32
FR6 wiring . . . . .	37
Power wiring selection . . . . .	38
Cable selection: Power and motor leads . . . . .	38
Line (Mains) and motor cable installation . . . . .	38
Connection tightening torque . . . . .	39
Cable routing . . . . .	40
Wiring the VFD . . . . .	40
Rubber grommet installation instructions . . . . .	41
Control board . . . . .	47
Safe torque off (STO) . . . . .	48
Connection to power section . . . . .	48
Three-phase input connection . . . . .	48
Terminal designations in the power section . . . . .	48
Ground connection . . . . .	48
Product modified sticker . . . . .	49
Checking the cable and motor insulation . . . . .	49

### CHAPTER 7—EMC INSTALLATION

EMC Measures in the control panel . . . . .	50
Earthing . . . . .	50
Screen earth kit . . . . .	50
Installation requirements . . . . .	51
International EMC protection cable requirements . . . . .	52
Installation in corner-grounded network and IT system . . . . .	53

### APPENDIX A—TECHNICAL DATA AND SPECIFICATIONS

Technical data . . . . .	55
--------------------------	----

### APPENDIX B—INSTALLATION GUIDELINES

Cable and fuse sizing . . . . .	58
Temperature deratings . . . . .	63
Heat loss data . . . . .	70
Brake resistor sizing . . . . .	71
Efficiency ratings . . . . .	72

### APPENDIX C—DIMENSION DRAWINGS

### APPENDIX D—SAFETY INSTRUCTIONS FOR UL AND CUL

UL Standards compliance . . . . .	90
Field wiring . . . . .	93

### APPENDIX E—STO FUNCTION

Description of safety function . . . . .	100
Requirement for installation, commission, maintenance . . . . .	102
Requirements of proof test . . . . .	102

### APPENDIX F—UL CERTIFICATE OF COMPLIANCE

UL certificate of compliance . . . . .	103
CE declaration of conformance . . . . .	103

List of figures

Figure 1. RTC battery connection . . . . . 1  
Figure 2. Rating label—DG1 . . . . . 2  
Figure 3. Rating label—DH1 . . . . . 2  
Figure 4. Carton label—DG1 . . . . . 2  
Figure 5. Carton label—DH1 . . . . . 2  
Figure 6. Catalog numbering system . . . . . 3  
Figure 7. Drive system (PDS = power drive system) . . . . . 15  
Figure 8. AC power networks with grounded neutral point (TN-/TT networks) . . . . . 16  
Figure 9. Description of the PowerXL Series . . . . . 18  
Figure 10. Block diagram, elements of PowerXL frequency inverters . . . . . 19  
Figure 11. Selection criteria . . . . . 20  
Figure 12. Identification on the FI circuit breakers . . . . . 22  
Figure 13. EMC Measures . . . . . 24  
Figure 14. Parallel connection . . . . . 26  
Figure 15. Example of a motor ratings plate . . . . . 26  
Figure 16. Star and delta circuit types . . . . . 26  
Figure 17. V/Hz characteristic curve . . . . . 27  
Figure 18. Bypass motor control (example) . . . . . 28  
Figure 19. Mounting space . . . . . 30  
Figure 20. Open Drives FR0–FR6 . . . . . 31  
Figure 21. FR6 wiring layout . . . . . 37  
Figure 22. Brake resistor wiring . . . . . 38  
Figure 23. Input power and motor cable stripping lengths . . . . . 39  
Figure 24. Ground wiring . . . . . 42  
Figure 25. Terminal block layout . . . . . 45  
Figure 26. Basic internal control wiring diagram . . . . . 46  
Figure 27. PowerXL variable frequency drive . . . . . 47  
Figure 28. Connection to power section . . . . . 48  
Figure 29. Grounding . . . . . 48  
Figure 30. FR0 grounding . . . . . 49  
Figure 31. Product modified sticker . . . . . 49  
Figure 34. EMC-Compliant Setup—230 Vac, 460/480 Vac, 600 Vac . . . . . 51  
Figure 35. Cable description . . . . . 52  
Figure 36. Location of the EMC Screw in Frame 0 . . . . . 53  
Figure 37. Locations of the EMC Screw in Frame 1 and Frame 3 . . . . . 53  
Figure 38. Locations of EMC and MOV Screws for Frame 2 and Frame 4 . . . . . 54  
Figure 39. Locations of the EMC Screws in Frame 5 and Frame 6 . . . . . 54  
Figure 40. FR0 Dimension drawing . . . . . 77  
Figure 41. FR1 Dimension drawing . . . . . 78  
Figure 42. FR1 Dimension drawing flange mount . . . . . 79  
Figure 43. FR2 Dimension drawing . . . . . 80  
Figure 44. FR2 Dimension drawing flange mount . . . . . 81  
Figure 45. FR3 Dimension drawing . . . . . 82  
Figure 46. FR3 Dimension drawing flange mount . . . . . 83  
Figure 47. FR4 Dimension drawing . . . . . 84  
Figure 48. FR4 Dimension drawing flange mount . . . . . 85  
Figure 49. FR5 Dimension drawing . . . . . 86  
Figure 50. FR5 Dimension drawing flange mount . . . . . 87  
Figure 51. FR6 Dimensional drawing . . . . . 88  
Figure 52. FR6 Dimensional drawing flange mount . . . . . 89  
Figure 53. Functional block diagram . . . . . 100  
Figure 54. Reliability block diagram . . . . . 100  
Figure 55. STO terminal block in PowerXL control board . . . . . 102  
Figure 56. Thermistor STO wiring diagram . . . . . 102

## List of tables

Table 1. Common abbreviations . . . . .	1
Table 2. Open Type IP20 . . . . .	4
Table 3. Type 1/IP21 . . . . .	4
Table 4. Type 12/IP54 . . . . .	5
Table 5. Open Type IP20 . . . . .	5
Table 6. Type 1/IP21 . . . . .	6
Table 7. Type 12/IP54 . . . . .	6
Table 8. Type 1/IP21 . . . . .	7
Table 9. Type 12/IP54 . . . . .	7
Table 10. Frame 0 . . . . .	8
Table 11. Frame 1 . . . . .	8
Table 12. Frame 2 . . . . .	8
Table 13. Frame 3 . . . . .	9
Table 14. Frame 4 . . . . .	9
Table 15. Frame 5 . . . . .	10
Table 16. Frame 6 . . . . .	11
Table 17. Frame 0 . . . . .	11
Table 18. Frame 1 . . . . .	11
Table 19. Frame 2 . . . . .	12
Table 20. Frame 3 . . . . .	12
Table 21. Frame 4 . . . . .	13
Table 22. Frame 5 . . . . .	13
Table 23. Frame 6 . . . . .	14
Table 24. Drive system components . . . . .	15
Table 25. Elements of PowerXL frequency inverters . . . . .	19
Table 26. Maintenance measures and intervals . . . . .	21
Table 27. Motor power cable EMC guidelines . . . . .	24
Table 28. Assignment of frequency inverters to example motor circuit . . . . .	27
Table 29. Bypass motor control . . . . .	28
Table 30. Space requirements for mounting the PowerXL Series VFD and airflow . . . . .	30
Table 31. Mounting drive dimensions . . . . .	31
Table 32. Tightening torque . . . . .	39
Table 33. Spacing between parallel motor cables . . . . .	39
Table 34. Maximum motor power cable length 230/480 V . . . . .	39
Table 35. Maximum motor power cable lengths 575 V . . . . .	39
Table 36. Input power and motor cable stripping and wire lengths . . . . .	39
Table 37. DG1 I/O connection . . . . .	43
Table 38. DH1 I/O connection . . . . .	44
Table 39. I/O specifications . . . . .	45
Table 40. 1st Environment 2nd environment EMC levels according to EN 61800-3 (2004) . . . . .	52
Table 41. Motor power cable EMC guidelines . . . . .	52
Table 42. Cable categories . . . . .	52
Table 43. PowerXL Series . . . . .	55
Table 44. North America cable and fuse sizes—208 Vac to 240 Vac ratings . . . . .	58
Table 45. International cable and fuse sizes—208 Vac to 240 Vac ratings . . . . .	59
Table 46. North America cable and fuse sizes—440 Vac to 500 Vac ratings . . . . .	60
Table 47. International cable and fuse sizes—380 Vac to 440 Vac ratings . . . . .	61
Table 48. North America cable and fuse sizes—525 Vac to 600 Vac ratings . . . . .	62
Table 49. 230 V temperature deratings (VT) . . . . .	64
Table 50. 230 V temperature deratings (CT) . . . . .	65
Table 51. 480 V temperature deratings (VT) . . . . .	66

**List of tables, continued**

Table 52. 480 V temperature deratings (CT) . . . . . **67**  
Table 53. 600 V temperature deratings (VT) . . . . . **68**  
Table 54. 600 V temperature deratings (CT) . . . . . **69**  
Table 55. 230 V heat loss data . . . . . **70**  
Table 56. 400 V heat loss data . . . . . **70**  
Table 57. 600 V heat loss data . . . . . **71**  
Table 58. 230 V idle heat loss FR0~FR6 . . . . . **71**  
Table 59. 480 V idle heat loss FR0~FR6 . . . . . **71**  
Table 60. 575 V idle heat loss FR1~FR6 . . . . . **71**  
Table 61. Brake resistor sizing data . . . . . **71**  
Table 62. 230 V FR0-Xhp efficiency rating . . . . . **72**  
Table 63. 230 V FR1-4hp efficiency rating . . . . . **72**  
Table 64. 230 V FR2-10hp efficiency rating . . . . . **72**  
Table 65. 230 V FR3-20hp efficiency rating . . . . . **72**  
Table 66. 230 V FR4-40hp efficiency rating . . . . . **73**  
Table 67. 230 V FR5-75hp efficiency rating . . . . . **73**  
Table 68. 400 V FR0-Xhp efficiency rating . . . . . **73**  
Table 69. 400 V FR1-7.5hp efficiency rating . . . . . **73**  
Table 70. 400 V FR2-20hp efficiency rating . . . . . **74**  
Table 71. 400 V FR3-40hp efficiency rating . . . . . **74**  
Table 72. 400 V FR4-75hp efficiency rating . . . . . **74**  
Table 73. 400 V FR5-150hp efficiency rating . . . . . **74**  
Table 74. 575 V FR1-7.5hp efficiency rating . . . . . **75**  
Table 75. 575 V FR2-20hp efficiency rating . . . . . **75**  
Table 76. 575 V FR3-40hp efficiency rating . . . . . **75**  
Table 77. 575 V FR4-75hp efficiency rating . . . . . **76**  
Table 78. 575 V FR5-150hp efficiency rating . . . . . **76**  
Table 79. Protection ratings—480 V drive series . . . . . **91**  
Table 80. Protection ratings—230 V drive series . . . . . **92**  
Table 81. Protection ratings—575 V drive series . . . . . **93**  
Table 82. Required line and motor wire torque (480 V) . . . . . **94**  
Table 83. Required line and motor wire torque (230 V) . . . . . **95**  
Table 84. Required line and motor wire torque (575 V) . . . . . **96**  
Table 85. Required grounding wire torque (480 V) . . . . . **97**  
Table 86. Required grounding wire torque (230 V) . . . . . **98**  
Table 87. Required grounding wire torque (575 V) . . . . . **99**  
Table 88. Safety-related parameters . . . . . **100**  
Table 89. Power supply and input/output . . . . . **100**  
Table 90. Environmental and EMC conditions . . . . . **101**



## Safety



### **WARNING! DANGEROUS ELECTRICAL VOLTAGE!**

#### **Before commencing the installation**

- Disconnect the power supply of the device
  - Ensure that devices cannot be accidentally restarted
  - Verify isolation from the supply
  - Earth and short circuit the device
  - Cover or enclose any adjacent live components
  - Only suitably qualified personnel in accordance with EN 50110-1/-2 (VDE 0105 Part 100) may work on this device/system
  - Before installation and before touching the device ensure that you are free of electrostatic charge
  - The functional earth (FE, PES) must be connected to the protective earth (PE) or the potential equalization. The system installer is responsible for implementing this connection
  - Connecting cables and signal lines should be installed so that inductive or capacitive interference does not impair the automation functions
  - Install automation devices and related operating elements in such a way that they are well protected against unintentional operation
  - Suitable safety hardware and software measures should be implemented for the I/O interface so that an open circuit on the signal side does not result in undefined states in the automation devices
  - Ensure a reliable electrical isolation of the extra-low voltage of the 24 V supply. Only use power supply units complying with IEC 60364-4-41 (VDE 0100 Part 410) or HD384.4.41 S2
  - Deviations of the input voltage from the rated value must not exceed the tolerance limits given in the specifications, otherwise this may cause malfunction and dangerous operation
  - Emergency stop devices complying with IEC/EN 60204-1 must be effective in all operating modes of the automation devices. Unlatching the emergency-stop devices must not cause a restart
  - Devices that are designed for mounting in housings or control cabinets must only be operated and controlled after they have been installed and with the housing closed. Desktop or portable units must only be operated and controlled in enclosed housings
  - Measures should be taken to ensure the proper restart of programs interrupted after a voltage dip or failure. This should not cause dangerous operating states even for a short time. If necessary, emergency-stop devices should be implemented
  - Wherever faults in the automation system may cause injury or material damage, external measures must be implemented to ensure a safe operating state in the event of a fault or malfunction (for example, by means of separate limit switches, mechanical interlocks, and so on)
  - Depending on their degree of protection, adjustable frequency drives may contain live bright metal parts, moving or rotating components, or hot surfaces during and immediately after operation
  - Removal of the required covers, improper installation, or incorrect operation of motor or adjustable frequency drive may cause the failure of the device and may lead to serious injury or damage
  - The applicable national accident prevention and safety regulations apply to all work carried out on live adjustable frequency drives
  - The electrical installation must be carried out in accordance with the relevant regulations (for example, with regard to cable cross sections, fuses, PE)
  - Transport, installation, commissioning, and maintenance work must be carried out only by qualified personnel (IEC 60364, HD 384 and national occupational safety regulations)
  - Installations containing adjustable frequency drives must be provided with additional monitoring and protective devices in accordance with the applicable safety regulations. Modifications to the adjustable frequency drives using the operating software are permitted
  - All covers and doors must be kept closed during operation
  - To reduce hazards for people or equipment, the user must include in the machine design measures that restrict the consequences of a malfunction or failure of the drive (increased motor speed or sudden standstill of motor). These measures include:
    - Other independent devices for monitoring safety-related variables (speed, travel, end positions, and so on)
    - Electrical or non-electrical system-wide measures (electrical or mechanical interlocks)
  - Never touch live parts or cable connections of the adjustable frequency drive after it has been disconnected from the power supply. Due to the charge in the capacitors, these parts may still be live after disconnection. Fit appropriate warning signs
- Read this manual thoroughly and make sure you understand the procedures before you attempt to install, set up, operate or carry out any maintenance work on this PowerXL Adjustable Frequency Drive.

## Definitions and symbols

---

### WARNING

---

This symbol indicates high voltage. It calls your attention to items or operations that could be dangerous to you and other persons operating this equipment. Read the message and follow the instructions carefully.



This symbol is the "Safety Alert Symbol." It occurs with either of two signal words: CAUTION or WARNING, as described below.

---

### WARNING

---

Indicates a potentially hazardous situation which, if not avoided, can result in serious injury or death.

---

### CAUTION

---

Indicates a potentially hazardous situation which, if not avoided, can result in minor to moderate injury, or serious damage to the product. The situation described in the CAUTION may, if not avoided, lead to serious results. Important safety measures are described in CAUTION (as well as WARNING).

### Hazardous high voltage

---

### WARNING

---

Motor control equipment and electronic controllers are connected to hazardous line voltages. When servicing drives and electronic controllers, there may be exposed components with housings or protrusions at or above line potential. Extreme care should be taken to protect against shock.

- Stand on an insulating pad and make it a habit to use only one hand when checking components
- Always work with another person in case an emergency occurs
- Disconnect power before checking controllers or performing maintenance
- Be sure equipment is properly earthed
- Wear safety glasses whenever working on electronic controllers or rotating machinery

---

### WARNING

---

The components in the drive's power section remain energized after the supply voltage has been switched off. After disconnecting the supply, wait at least five minutes before removing the cover to allow the intermediate circuit capacitors to discharge.

Pay attention to hazard warnings!



**DANGER**  
5 MIN

---

### WARNING

---

Electric shock hazard—risk of injuries! Carry out wiring work only if the unit is de-energized.

---

### WARNING

---

Do not perform any modifications on the AC drive when it is connected to mains.

### Warnings and cautions

---

### WARNING

---

Be sure to ground the unit following the instructions in this manual. Ungrounded units may cause electric shock and/or fire.

---

### WARNING

---

This equipment should only be installed, adjusted, and serviced by qualified electrical maintenance personnel familiar with the construction and operation of this type of equipment and the hazards involved. Failure to observe this precaution could result in death or severe injury.

---

### WARNING

---

Components within the drive are live when it is connected to power. Contact with this voltage is extremely dangerous and may cause death or severe injury.

---

### WARNING

---

Line terminals (L1, L2, L3), motor terminals (U, V, W) and the DC link/brake resistor terminals (DC-, DC+/R+, R-) are live when the drive is connected to power, even if the motor is not running. Contact with this voltage is extremely dangerous and may cause death or severe injury.

---

### WARNING

---

Even though the control I/O-terminals are isolated from line voltage, the relay outputs and other I/O-terminals may have dangerous voltage present even when the drive is disconnected from power. Contact with this voltage is extremely dangerous and may cause death or severe injury.

---

### WARNING

---

This equipment has a large capacitive leakage current during operation, which can cause enclosure parts to be above ground potential. Proper grounding, as described in this manual, is required. Failure to observe this precaution could result in death or severe injury.

**⚠ WARNING**

Before applying power to this drive, make sure that the front and cable covers are closed and fastened to prevent exposure to potential electrical fault conditions. Failure to observe this precaution could result in death or severe injury.

**⚠ WARNING**

An upstream disconnect/protective device must be provided as required by the National Electric Code® (NEC®). Failure to follow this precaution may result in death or severe injury.

**⚠ WARNING**

This drive can cause a DC current in the protective earthing conductor. Where a residual current-operated protective (RCD) or monitoring (RCM) device is used for protection in case of direct or indirect contact, only an RCD or RCM of Type B is allowed on the supply side of this product.

**⚠ WARNING**

Carry out wiring work only after the drive has been correctly mounted and secured.

**⚠ WARNING**

Before opening the drive covers:

- Disconnect all power to the drive, including external control power that may be present
- Wait a minimum of five minutes after all the lights on the keypad are off. This allows time for the DC bus capacitors to discharge
- A hazard voltage may still remain in the DC bus capacitors even if the power has been turned off. Confirm that the capacitors have fully discharged by measuring their voltage using a multimeter set to measure the DC voltage

Failure to follow these precautions may cause death or severe injury.

**⚠ WARNING**

The opening of the branch-circuit protective device may be an indication that a fault current has been interrupted. To reduce the risk of fire or electric shock, current-carrying parts and other components of the controller should be examined and replaced if damaged. If burnout of the current element of an overload relay occurs, the complete overload relay must be replaced.

**⚠ WARNING**

Operation of this equipment requires detailed installation and operation instructions provided in the Installation/Operation manual intended for use with this product. It should be retained with this device at all times. A hard copy of this information may be ordered from literature fulfillment.

**⚠ WARNING**

Before servicing the drive:

- Disconnect all power to the drive, including external control power that may be present
- Place a “DO NOT TURN ON” label on the disconnect device
- Lock the disconnect device in the open position

Failure to follow these instructions will result in death or serious injury.

**⚠ WARNING**

The drive outputs (U, V, W) must not be connected to the input voltage or the utility line power as severe damage to the device may occur and there may be a risk of fire.

**⚠ WARNING**

The heat sink and/or outer enclosure may reach a high temperature.

Pay attention to hazard warnings!



Hot Surface—Risk of Burn. DO NOT TOUCH!

**⚠ WARNING**

In a domestic environment, this product may cause radio interference, in which case supplementary mitigation measures may be required.

**⚠ CAUTION**

Any electrical or mechanical modification to this drive without prior written consent of manufacturer will void all warranties and may result in a safety hazard in addition and voiding of the UL® listing.

**⚠ CAUTION**

Install this drive on flame-resistant material such as a steel plate to reduce the risk of fire.

**⚠ CAUTION**

Install this drive on a perpendicular surface that is able to support the weight of the drive and is not subject to vibration, to lessen the risk of the drive falling and being damaged and/or causing personal injury.

---

**⚠ CAUTION**

Prevent foreign material such as wire clippings or metal shavings from entering the drive enclosure, as this may cause arcing damage and fire.

---

**⚠ CAUTION**

Install this drive in a well-ventilated room that is not subject to temperature extremes, high humidity, or condensation, and avoid locations that are directly exposed to sunlight, or have high concentrations of dust, corrosive gas, explosive gas, inflammable gas, grinding fluid mist, etc. Improper installation may result in a fire hazard.

---

**⚠ CAUTION**

When selecting the cable cross-section, take the voltage drop under load conditions into account. The consideration of other standards is the responsibility of the user.

The user is responsible for compliance with all international and national electrical standards in force concerning protective grounding of all equipment.

---

**⚠ CAUTION**

The specified minimum PE conductor cross-sections in this manual must be maintained.

Touch current in this equipment exceeds 3.5 mA (AC). The minimum size of the protective earthing conductor shall comply with the requirements of EN 61800-5-1 and/or the local safety regulations.

---

**⚠ CAUTION**

Touch currents in this frequency inverter are greater than 3.5 mA (AC). According to product standard IEC/EN 61800-5-1, an additional equipment grounding conductor of the same cross-sectional area as the original protective earthing conductor must be connected, or the cross-section of the equipment grounding conductor must be at least 10 mm<sup>2</sup> Cu. Drive requires that only copper conductor should be used.

---

**⚠ CAUTION**

Debounced inputs may not be used in the safety circuit diagram. Residual current circuit breakers (RCD) are only to be installed between the AC power supply network and the drive.

---

**⚠ CAUTION**

Debounced inputs may not be used in the safety circuit diagram. If you are connecting multiple motors on one drive, you must design the contactors for the individual motors according to utilization category AC-3.

Selecting the motor contactor is done according to the rated operational current of the motor to be connected.

---

**⚠ CAUTION**

Debounced inputs may not be used in the safety circuit diagram. A changeover between the drive and the input supply must take place in a voltage-free state.

---

**⚠ CAUTION**

Debounced inputs may not be used in the safety circuit diagram. Fire hazard!

Only use cables, protective switches, and contactors that feature the indicated permissible nominal current value.

---

**⚠ CAUTION**

Before connecting the drive to AC mains make sure that the EMC protection class settings of the drive are appropriately made according to instructions in this manual.

- If the drive is to be used in a floating distribution network, remove screws at MOV and EMC. See “Installation in Corner-Grounded Network” on **Page 53** and “Installation in IT System” on **Page 53** respectively
- Disconnect the internal EMC filter when installing the drive on an IT system (an ungrounded power system or a high-resistance-grounded [over 30 ohm] power system), otherwise the system will be connected to ground potential through the EMC filter capacitors. This may cause danger, or damage the drive
- Disconnect the internal EMC filter when installing the drive on a corner grounded TN system, otherwise the drive will be damaged

---

**NOTE**

When the internal EMC filter is disconnected, the drive might be not EMC compatible.

- Do not attempt to install or remove the MOV or EMC screws while power is applied to the drive’s input terminals

---

**Motor and equipment safety**

---

**⚠ CAUTION**

Do not perform any meggar or voltage withstand tests on any part of the drive or its components. Improper testing may result in damage.

---

**⚠ CAUTION**

Prior to any tests or measurements of the motor or the motor cable, disconnect the motor cable at the drive output terminals (U, V, W) to avoid damaging the drive during motor or cable testing.

---

**⚠ CAUTION**

---

Do not touch any components on the circuit boards. Static voltage discharge may damage the components.

---

**⚠ CAUTION**

---

Before starting the motor, check that the motor is mounted properly and aligned with the driven equipment. Ensure that starting the motor will not cause personal injury or damage equipment connected to the motor.

---

**⚠ CAUTION**

---

Set the maximum motor speed (frequency) in the drive according to the requirements of the motor and the equipment connected to it. Incorrect maximum frequency settings can cause motor or equipment damage and personal injury.

---

**⚠ CAUTION**

---

Before reversing the motor rotation direction, ensure that this will not cause personal injury or equipment damage.

---

**⚠ CAUTION**

---

Make sure that no power correction capacitors are connected to the drive output or the motor terminals to prevent drive malfunction and potential damage.

---

**⚠ CAUTION**

---

Make sure that the drive output terminals (U, V, W) are not connected to the utility line power as severe damage to the drive may occur.

---

**⚠ CAUTION**

---

When the control terminals of two or more drive units are connected in parallel, the auxiliary voltage for these control connections must be taken from a single source which can either be one of the units or an external supply.

---

**⚠ CAUTION**

---

The drive will start up automatically after an input voltage interruption if the external run command is on.

---

**⚠ CAUTION**

---

Do not control the motor with the disconnecting device (disconnecting means); instead, use the control panel start and stop keys and, or commands via the I/O board of the drive. The maximum allowed number of charging cycles of the DC capacitors (i.e. power-ups by applying power) is five in ten minutes.

---

**⚠ CAUTION**

---

**Improper drive operation:**

- If the drive is not turned on for a long period, the performance of its electrolytic capacitors will be reduced
- If it is stopped for a prolonged period, turn the drive on at least every six months for at least 5 hours to restore the performance of the capacitors, and then check its operation. It is recommended that the drive is not connected directly to the line voltage. The voltage should be increased gradually using an adjustable AC source

**Failure to follow these instructions can result in injury and/or equipment damage.**

For more technical information, contact the factory or your local sales representative.

## Sécurité



### **AVERTISSEMENT ! TENSION ÉLECTRIQUE DANGEREUSE !**

#### **Avant de commencer l'installation**

- Débrancher l'alimentation de l'appareil
- S'assurer que les dispositifs ne peuvent pas être accidentellement redémarrés
- Vérifier l'isolement de l'alimentation
- Mettre l'appareil à la terre et le protéger contre les courts-circuits
- Couvrir ou enfermer tout composant sous tension adjacent
- Seul le personnel qualifié conformément à la norme EN 50110-1/-2 (VDE 0105 Partie 100) peut travailler sur cet appareil/ce système
- Avant l'installation et avant de toucher l'appareil, s'assurer de ne porter aucune charge électrostatique
- La terre fonctionnelle (FE, PSE) doit être raccordée à la terre de protection (PE) ou la compensation de potentiel. L'installateur du système a la responsabilité d'assurer cette connexion
- Les câbles de connexion et les lignes de signal doivent être installés de façon à ce que les interférences capacitatives ou inductives ne compromettent pas les fonctions d'automatisation
- Installer les appareils d'automatisation et les éléments de fonctionnement associés de manière à ce qu'ils soient bien protégés contre tout fonctionnement accidentel
- Des dispositifs de sécurité matériels et logiciels appropriés doivent être utilisés en rapport avec l'interface des E/S afin qu'un circuit ouvert sur le côté signal ne résulte pas en états indéfinis dans les dispositifs d'automatisation
- Assurer une isolation électrique fiable sur le côté tension extra basse de l'alimentation 24 V. Utiliser uniquement des blocs d'alimentation conformes à la norme CEI 60364-4-41 (VDE 0100, partie 410) ou HD384.4.41 S2
- Les écarts entre la tension d'entrée et la tension nominale ne doivent pas dépasser les limites de tolérance indiquées dans les spécifications, au risque de provoquer un mauvais fonctionnement et une utilisation dangereuse du système
- Les dispositifs d'arrêt d'urgence conformes à la norme CEI/EN 60204-1 doivent être efficace dans tous les modes de fonctionnement des dispositifs d'automatisation. Le déverrouillage des dispositifs d'arrêt d'urgence ne doit pas entraîner un redémarrage
- Les dispositifs conçus pour un montage dans des boîtiers ou armoires de commande ne doivent être utilisés et contrôlés qu'après avoir été installés et avec le boîtier fermé. Les unités de bureau ou portatives ne doivent être utilisées et contrôlées que dans leurs boîtiers fermés
- Des mesures doivent être prises pour assurer un bon redémarrage des programmes interrompus après une chute ou une panne de tension. Ceci ne doit pas causer des états de fonctionnement dangereux, même pour un court laps de temps. Si nécessaire, des dispositifs d'arrêt d'urgence doivent être utilisés
- Quand des défaillances du système d'automatisation peuvent entraîner des blessures ou des dommages matériels, des mesures externes doivent être appliquées pour assurer un état de fonctionnement sans danger en cas de panne ou de mauvais fonctionnement (par exemple au moyen de disjoncteurs séparés, de verrouillages mécaniques, etc.)
- En fonction de leur degré de protection, les entraînements à fréquence variable peuvent contenir des pièces métalliques sous tension, des composants rotatifs ou en mouvement et des surfaces brûlantes, pendant le fonctionnement et immédiatement après l'arrêt
- Le retrait des protections requises, une installation incorrecte ou un mauvais fonctionnement du moteur ou de l'entraînement à fréquence variable peuvent causer la défaillance de l'appareil et entraîner des blessures graves et des dommages importants
- La réglementation nationale applicable en matière de sécurité et de prévention des accidents s'applique à tous les travaux effectués sur les entraînements à fréquence variable sous tension
- L'installation électrique doit être effectuée conformément aux réglementations applicables (par exemple, en ce qui concerne les sections transversales des câbles, les fusibles, la mise à la terre de protection)
- Le transport, l'installation, la mise en service et les travaux de maintenance doivent être effectués uniquement par un personnel qualifié (IEC 60364, HD 384 et règles de sécurité du travail)
- Les installations contenant des entraînements à fréquence variable doivent être équipées de dispositifs de surveillance et de protection, conformément aux réglementations applicables en matière de sécurité. Les modifications des entraînements à fréquence variable réalisées à l'aide du logiciel d'exploitation sont autorisées



- Toutes les protections et les portes doivent être maintenues fermées pendant le fonctionnement
- Pour réduire les risques d'accidents et de dommages matériels, l'utilisateur doit inclure dans la conception de la machine des mesures limitant les conséquences de panne ou de mauvais fonctionnement de l'entraînement (augmentation de la vitesse ou arrêt soudain du moteur). Ces mesures comprennent:
  - Autres dispositifs indépendants de surveillance des variables en rapport avec la sécurité (vitesse, voyages, positions d'extrémité, etc.)
  - Mesures électriques ou non électriques appliquées à l'ensemble du système (verrouillages électriques ou mécaniques)
  - Ne jamais toucher les pièces sous tension ni les connexions des câbles de l'entraînement à fréquence variable après leur déconnexion de l'alimentation. En raison de la charge dans les condensateurs, ces pièces peuvent être encore sous tension après la déconnexion. Installer les panneaux d'avertissement appropriés.

Lire ce manuel en entier et s'assurer de bien comprendre les procédures avant de tenter d'installer, de configurer, d'utiliser et d'effectuer tout travail d'entretien sur cet entraînement à fréquence variable PowerXL.

## Définitions et symboles

### AVERTISSEMENT

Ce symbole indique une haute tension. Il attire l'attention sur les éléments ou les opérations qui pourraient être dangereux pour les personnes utilisant cet équipement. Lire attentivement le message et suivre attentivement les instructions.



Ce symbole est le « symbole d'alerte de sécurité ». Il accompagne les deux termes d'avertissement suivants : MISE EN GARDE ou AVERTISSEMENT, comme décrit ci-dessous.

### AVERTISSEMENT

Indique une situation potentiellement dangereuse qui, si elle n'est pas évitée, peut entraîner des blessures graves ou la mort.

### MISE EN GARDE

Indique une situation potentiellement dangereuse qui, si elle n'est pas évitée, peut entraîner des blessures légères à modérées et d'importants dégâts matériels. La situation décrite dans la MISE EN GARDE peut, si elle n'est pas évitée, entraîner des conséquences graves. Des mesures de sécurité importantes sont décrites dans les MISES EN GARDE (ainsi que dans les AVERTISSEMENTS).

## Haute tension dangereuse

### AVERTISSEMENT

L'équipement de contrôle du moteur et les contrôleurs électroniques sont branchés sur des tensions secteur dangereuses. Lors de l'entretien des entraînements et des contrôleurs électroniques, il peut y avoir des composants exposés avec des boîtiers ou des protubérances au niveau du potentiel du réseau ou au-dessus. Toutes les précautions doivent être prises pour se protéger contre les chocs électriques.

- Se tenir sur un tapis isolant et prendre l'habitude de n'utiliser qu'une seule main pour vérifier les composants
- Toujours travailler avec une autre personne lorsqu'une situation d'urgence se produit
- Débrancher l'alimentation avant de vérifier les contrôleurs ou d'effectuer des travaux d'entretien
- S'assurer que l'équipement est correctement relié à la terre
- Porter des lunettes de sécurité lors des travaux sur les contrôleurs électroniques ou les machines rotatives

### AVERTISSEMENT

Les composants de la section d'alimentation de l'entraînement restent sous tension après la coupure de la tension d'alimentation. Après la déconnexion de l'alimentation, attendre au moins cinq minutes avant de retirer le couvercle pour permettre la décharge des condensateurs du circuit intermédiaire.

Prêter attention aux avertissements signalant des dangers !



**DANGER**  
**5 MIN**

### AVERTISSEMENT

Risque de choc électrique - risque de blessures !  
Effectuer le câblage uniquement si l'unité n'est plus sous tension.

### AVERTISSEMENT

Ne pas effectuer de modifications sur l'entraînement CA lorsqu'il est connecté à l'alimentation secteur.

## Avertissements et mises en garde

### AVERTISSEMENT

S'assurer de mettre l'appareil à la terre en suivant les instructions de ce manuel. Les unités non mises à la terre peuvent causer des chocs électriques et des incendies.

### AVERTISSEMENT

Cet équipement ne doit être installé, réglé et entretenu que par un personnel d'entretien électrique qualifié connaissant la construction et le fonctionnement de ce type d'équipement, ainsi que les risques encourus. Le non-respect de cette précaution peut entraîner la mort ou des blessures graves.

### AVERTISSEMENT

Les composants à l'intérieur de l'entraînement sont sous tension lorsque l'entraînement est branché à l'alimentation. Le contact avec cette tension est extrêmement dangereux et peut causer la mort ou des blessures graves.

### AVERTISSEMENT

Les bornes de phase (L1, L2, L3), les bornes du moteur (U, V, W) et les bornes de résistance de liaison CC/frein (DC-, DC+ /R+, R-) sont sous tension lorsque l'entraînement est branché à l'alimentation, même si le moteur ne tourne pas. Le contact avec cette tension est extrêmement dangereux et peut causer la mort ou des blessures graves.

### AVERTISSEMENT

Même si les bornes E/S de commande sont isolées de la tension secteur, les sorties de relais et les autres bornes E/S peuvent présenter une tension dangereuse même lorsque l'entraînement est débranché. Le contact avec cette tension est extrêmement dangereux et peut causer la mort ou des blessures graves.

### AVERTISSEMENT

Cet équipement a un grand courant de fuite capacitif pendant le fonctionnement, ce qui peut mettre les pièces du boîtier à un niveau supérieur au potentiel de terre. Une mise à la terre appropriée, telle que décrite dans ce manuel, est nécessaire. Le non-respect de cette précaution peut entraîner la mort ou des blessures graves.

### AVERTISSEMENT

Avant de mettre l'entraînement sous tension, s'assurer que les protections avant et des câbles sont fermées et attachées pour empêcher l'exposition à d'éventuelles défaillances électriques. Le non-respect de cette précaution peut entraîner la mort ou des blessures graves.

### AVERTISSEMENT

Un dispositif de protection/déconnexion en amont doit être fourni, tel que requis par le code électrique national (NEC®). Le non-respect de cette précaution peut entraîner la mort ou des blessures graves.

### AVERTISSEMENT

Cet entraînement peut causer un courant CC dans le conducteur de mise à la terre de protection. Lorsqu'un dispositif de protection ou de surveillance à courant résiduel est utilisé pour la protection en cas de contact direct ou indirect, seul un dispositif de type B est autorisé sur le côté alimentation de ce produit.

### AVERTISSEMENT

Ne travailler sur le câblage qu'après que l'entraînement a été correctement monté et attaché.

### AVERTISSEMENT

Avant d'ouvrir les couvercles de l'entraînement :

- Débrancher toute l'alimentation allant à l'entraînement, y compris l'alimentation de commande externe pouvant être présente
- Attendre un minimum de cinq minutes après l'extinction de tous les voyants du clavier. Cela permet aux condensateurs de bus CC de se décharger
- Une tension dangereuse peut rester dans les condensateurs de bus CC même si l'alimentation a été coupée. Confirmer que les condensateurs sont entièrement déchargés en mesurant la tension à l'aide d'un multimètre réglé pour mesurer la tension CC

Le non-respect de cette précaution peut entraîner la mort ou des blessures graves.

### AVERTISSEMENT

L'ouverture du dispositif de protection du circuit de dérivation peut indiquer que le courant de défaut a été interrompu. Pour réduire le risque d'incendie ou de choc électrique, les pièces porteuses de courant et les autres composants du contrôleur doivent être examinés et remplacés s'ils sont endommagés. Si l'élément de courant d'un relais de surcharge a grillé, le relais de surcharge doit être intégralement remplacé.



**AVERTISSEMENT**

**Le fonctionnement de cet équipement nécessite le respect des instructions d'installation et de fonctionnement détaillées fournies dans le manuel d'installation/de fonctionnement destiné à être utilisé avec ce produit. Ce support doit être conservé avec cet appareil à tout moment.**

**AVERTISSEMENT**

**Avant de procéder à l'entretien de l'entraînement :**

- **Débrancher toute l'alimentation allant à l'entraînement, y compris l'alimentation de commande externe pouvant être présente**
- **Placer une étiquette « NE PAS UTILISER » sur le dispositif de déconnexion**
- **Verrouiller le dispositif de déconnexion en position ouverte**

**Le non-respect de ces instructions peut entraîner la mort ou des blessures graves.**

**AVERTISSEMENT**

**Les sorties de l'entraînement (U, V, W) ne doivent pas être connectées à la tension d'entrée ni à l'alimentation secteur, car ceci pourrait gravement endommager l'appareil et causer un incendie.**

**AVERTISSEMENT**

**Le dissipateur de chaleur et/ou le boîtier externe peuvent atteindre une température élevée.**

**Prêter attention aux avertissements signalant des dangers !**



**Surface brûlante - Risque de brûlure. NE PAS TOUCHER !**

**MISE EN GARDE**

Toute modification électrique ou mécanique de cet entraînement sans consentement écrit préalable annule toutes les garanties, peut entraîner un danger pour la sécurité et annuler l'homologation UL®.

**MISE EN GARDE**

Installer cet entraînement sur une matière résistante aux flammes, telle qu'une plaque d'acier, pour réduire les risques d'incendie.

**MISE EN GARDE**

Installer cet entraînement sur une surface perpendiculaire capable de supporter le poids de l'entraînement et non soumise à des vibrations afin de diminuer les risques de chute et de dommage de l'entraînement, ainsi que les risques de blessures.

**MISE EN GARDE**

Empêcher la pénétration de corps étrangers, tels que morceaux de fils et copeaux métalliques, dans le boîtier de l'entraînement, car ceci pourrait provoquer la formation d'un arc électrique et un incendie.

**MISE EN GARDE**

Installer cet entraînement dans une pièce bien aérée non soumise à des températures extrêmes, à une forte humidité ou à la condensation. Éviter les endroits directement exposés au soleil ou présentant de fortes concentrations de poussières, des gaz corrosifs, des gaz explosifs, des gaz inflammables, ou des vapeurs de liquide de meulage, etc. Une installation inadéquate peut entraîner un risque d'incendie.

**MISE EN GARDE**

Lors de la sélection de la section transversale des câbles, prendre en compte la chute de tension dans des conditions de charge. La prise en compte d'autres paramètres relève de la responsabilité de l'utilisateur.

Il relève de la responsabilité de l'utilisateur de respecter toutes les normes électriques nationales et internationales en vigueur concernant la mise à la terre de protection de l'ensemble de l'équipement.

**MISE EN GARDE**

Les spécifications minimum relatives aux sections transversales des conducteurs de terre de protection indiquées dans ce manuel doivent être respectées.

Le courant de fuite de cet équipement dépasse 3,5 mA (CA). La taille minimum du conducteur de la mise à la terre de protection doit être conforme aux exigences de la norme EN 61800-5-1 et/ou aux réglementations de sécurité locales.

**MISE EN GARDE**

Les courants de fuite de ce convertisseur de fréquence sont supérieures à 3,5 mA (CA). Conformément à la norme CEI/EN 61800-5-1, un conducteur de mise à la terre de l'équipement supplémentaire possédant la même superficie de coupe transversale que le conducteur de mise à la terre de protection d'origine doit être branché, ou la section transversale du conducteur de mise à la terre de l'équipement doit être d'au moins 10 mm<sup>2</sup> Cu. Seul un conducteur en cuivre doit être utilisé avec cet entraînement.

---

**⚠ MISE EN GARDE**

---

Les entrées anti-rebond ne sont pas permises dans le schéma du circuit de sécurité. Des disjoncteurs de courant résiduel (RCD) ne peuvent être installés qu'entre le réseau de courant alternatif et l'entraînement.

---

**⚠ MISE EN GARDE**

---

Les entrées anti-rebond ne sont pas permises dans le schéma du circuit de sécurité. Si plusieurs moteurs sont connectés à un entraînement, des contacteurs doivent être conçus pour les moteurs individuels conformément à la catégorie d'utilisation AC-3.

Sélectionner du contacteur du moteur en fonction du courant de fonctionnement nominal du moteur à connecter.

---

**⚠ MISE EN GARDE**

---

Les entrées anti-rebond ne sont pas permises dans le schéma du circuit de sécurité. Une commutation entre l'entraînement et l'alimentation d'entrée doit avoir lieu dans un état sans tension.

---

**⚠ MISE EN GARDE**

---

Les entrées anti-rebond ne sont pas permises dans le schéma du circuit de sécurité. Risque d'incendie !

Utiliser uniquement des câbles, des interrupteurs de protection et des contacteurs indiquant le courant nominal permis.

---

**⚠ MISE EN GARDE**

---

Avant de connecter l'entraînement à l'alimentation secteur CA, s'assurer que les réglages de la classe de protection CEM sont correctement effectués selon les instructions de ce manuel.

- Si l'entraînement doit être utilisé dans un réseau de distribution flottant, retirer les vis au niveau des VOM et CEM. Voir « Installation dans un réseau à une phase connectée à la terre (corner-grounded) » à la **Page 53** et « Installation dans un réseau IT » à la **Page 53** respectivement
- Débrancher le filtre CEM interne lors de l'installation de l'entraînement sur un réseau IT (système d'alimentation non mis à la terre ou système d'alimentation électrique mis à la terre haute résistance [plus de 30 ohms]) pour ne pas que le système soit connecté au potentiel de terre via les condensateurs du filtre CEM. Ceci peut être une cause de dangers ou endommager l'entraînement
- Débrancher le filtre CEM interne lors de l'installation de l'entraînement sur un système TN à une phase connectée à la terre pour ne pas endommager l'entraînement

**Remarque:** Lorsque le filtre CEM interne est débranché, l'entraînement peut ne pas être conforme aux normes de compatibilité électromagnétique.

- Ne pas tenter d'installer ou de retirer les vis des VOM et CEM lorsque l'alimentation est appliquée aux bornes d'entrée de l'entraînement

## Sécurité du moteur et de l'équipement

---

**⚠ MISE EN GARDE**

---

N'effectuer aucun test de résistance de tension ou au mégohmmètre sur toute partie de l'entraînement ou de ses composants. Un test inadéquat peut entraîner des dommages.

---

**⚠ MISE EN GARDE**

---

Avant tout test ou mesure du moteur ou du câble du moteur, débrancher le câble du moteur au niveau des bornes de sortie de l'entraînement (U, V, W) pour éviter d'endommager ce dernier lors des tests.

---

**⚠ MISE EN GARDE**

---

Ne toucher aucun composant sur les cartes de circuit. Les décharges d'électricité statique peuvent endommager les composants.

---

**⚠ MISE EN GARDE**

---

Avant de mettre le moteur en marche, vérifier qu'il est correctement monté et aligné avec l'équipement entraîné. S'assurer que le démarrage du moteur ne risque pas de provoquer des blessures ou d'endommager l'équipement connecté au moteur.

---

**⚠ MISE EN GARDE**

---

Régler la vitesse maximale du moteur (fréquence) dans l'entraînement conformément aux exigences du moteur et de l'équipement qui lui est connecté. Des réglages de fréquence maximum incorrects peuvent endommager le moteur ou l'équipement et causer des blessures.

---

**⚠ MISE EN GARDE**

---

Avant d'inverser le sens de rotation du moteur, veiller à ce que cela ne risque pas de provoquer des blessures ou des dommages matériels.

---

**⚠ MISE EN GARDE**

---

S'assurer qu'aucun condensateur de correction de puissance n'est connecté à la sortie de l'entraînement ou aux bornes du moteur pour éviter un mauvais fonctionnement de l'entraînement et des dommages potentiels.

---

** MISE EN GARDE**

---

S'assurer que les bornes de sortie de l'entraînement (U, V, W) ne sont pas connectées à l'alimentation secteur, ce qui pourrait causer de graves dommages à l'entraînement.

---

** MISE EN GARDE**

---

Lorsque les bornes de commande de deux ou plusieurs unités d'entraînement sont raccordées en parallèle, la tension auxiliaire de ces connexions de commande doit être fournie par une source unique, qui peut être soit l'une des unités, soit une alimentation externe.

---

** MISE EN GARDE**

---

L'entraînement démarre automatiquement après une interruption de la tension d'entrée si la commande de démarrage externe est active.

---

** MISE EN GARDE**

---

Ne pas commander le moteur avec le dispositif de déconnexion ; à la place, utiliser les touches de marche et d'arrêt du tableau de contrôle ou les commandes du tableau des E/S de l'entraînement. Le nombre de cycles de charge maximum permis des condensateurs CC (c'est-à-dire les mises sous tension par application de puissance) est de cinq en dix minutes.

---

** MISE EN GARDE**

---

**Fonctionnement incorrect de l'entraînement :**

- Si l'entraînement n'est pas mis en marche pendant une longue période, la performance de ses condensateurs électrolytiques sera réduite
- S'il est arrêté pour une période prolongée, le mettre en marche au moins tous les six mois pendant au moins 5 heures pour restaurer la performance des condensateurs, puis vérifier son fonctionnement. Il est recommandé de ne pas brancher l'entraînement directement sur la tension secteur. La tension doit être augmentée progressivement en utilisant une source CA réglable

**Le non-respect de ces instructions peut entraîner des blessures ou des dégâts matériels.**

Pour plus d'informations techniques, contacter l'usine ou le représentant commercial local.



## Chapter 1—PowerXL Series overview

This chapter describes the purpose and contents of this manual, the receiving inspection recommendations and the PowerXL Series Open Drive catalog numbering system.

### How to use this manual

The purpose of this manual is to provide you with information necessary to install, set and customize parameters, start up, troubleshoot and maintain the PowerXL Series Variable Frequency Drive (VFD). To provide for safe installation and operation of the equipment, read the safety guidelines at the beginning of this manual and follow the procedures outlined in the following chapters before connecting power to the PowerXL Series VFD. Keep this operating manual handy and distribute to all users, technicians and maintenance personnel for reference.

### Receiving and inspection

The PowerXL Series VFD has met a stringent series of factory quality requirements before shipment. It is possible that packaging or equipment damage may have occurred during shipment. After receiving your PowerXL Series VFD, please check for the following:

Check to make sure that the package includes the Instruction Leaflet, Quick Start Guide and accessory packet. The accessory packet includes:

- Rubber grommets
- Control cable grounding clamps
- Additional grounding screw

Inspect the unit to ensure it was not damaged during shipment.

Make sure that the part number indicated on the nameplate corresponds with the catalog number on your order.

If shipping damage has occurred, please contact and file a claim with the carrier involved immediately.

If the delivery does not correspond to your order, please contact your representative.

**Note:** Do not destroy the packing. The template printed on the protective cardboard can be used for marking the mounting points of the PowerXL VFD on the wall or in a cabinet.

### Real time clock battery activation

To activate the real time clock (RTC) functionality in the PowerXL Series VFD, the RTC battery (already mounted in the drive) must be connected to the control board.

Simply remove the primary drive cover, locate the RTC battery directly below the keypad, and connect the white 2-wire connector to the receptacle on the control board.

**Figure 1. RTC battery connection**

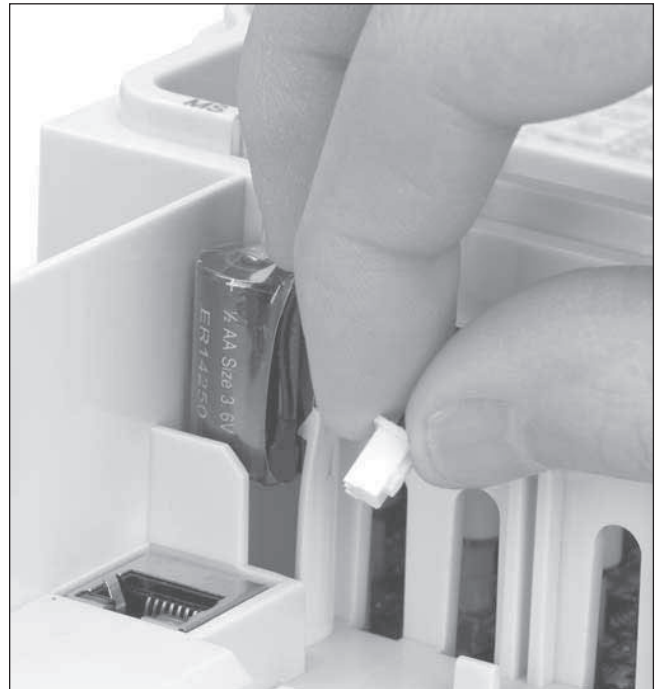
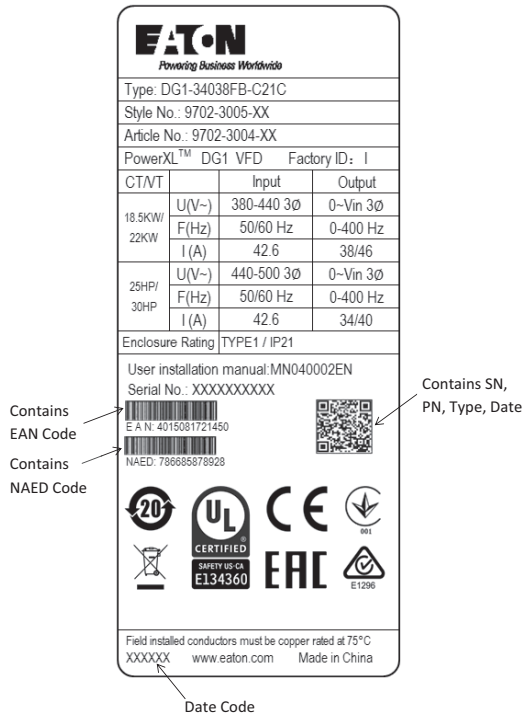

**Table 1. Common abbreviations**

Abbreviation	Definition
CT	Constant torque with high overload rating (150%)
VT	Variable torque with low overload rating (110%)
$I_H$	High overload current (150%)
$I_L$	Low overload current (110%)
VFD	Variable Frequency Drive
RTC	Real Time Clock

Rating label

Figure 2. Rating label—DG1



Carton labels (U.S. and Europe)

Figure 4. Carton label—DG1

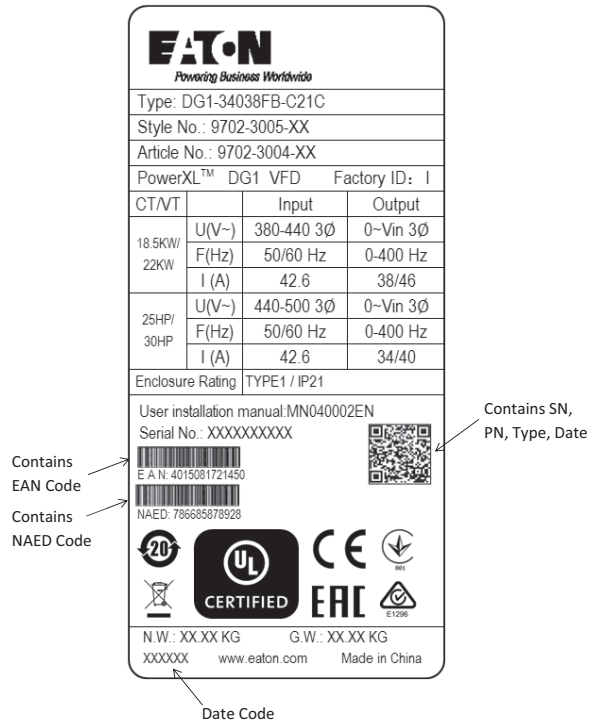

Figure 3. Rating label—DH1

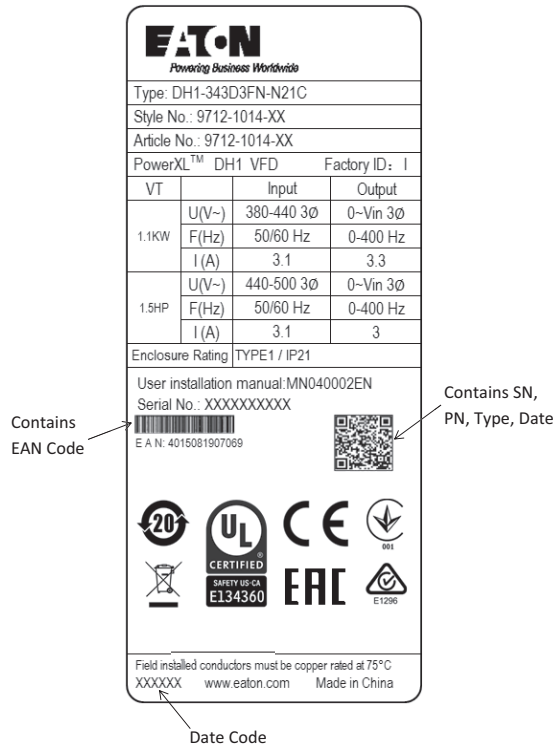
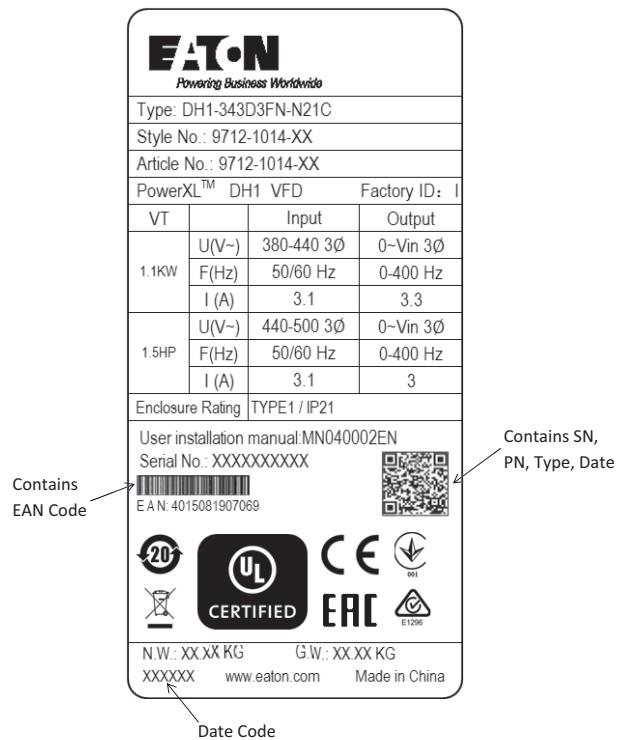

Figure 5. Carton label—DH1



### Catalog number system

Catalog number system is for illustrative purposes only and not to be used to create new catalog numbers.

Figure 6. Catalog numbering system

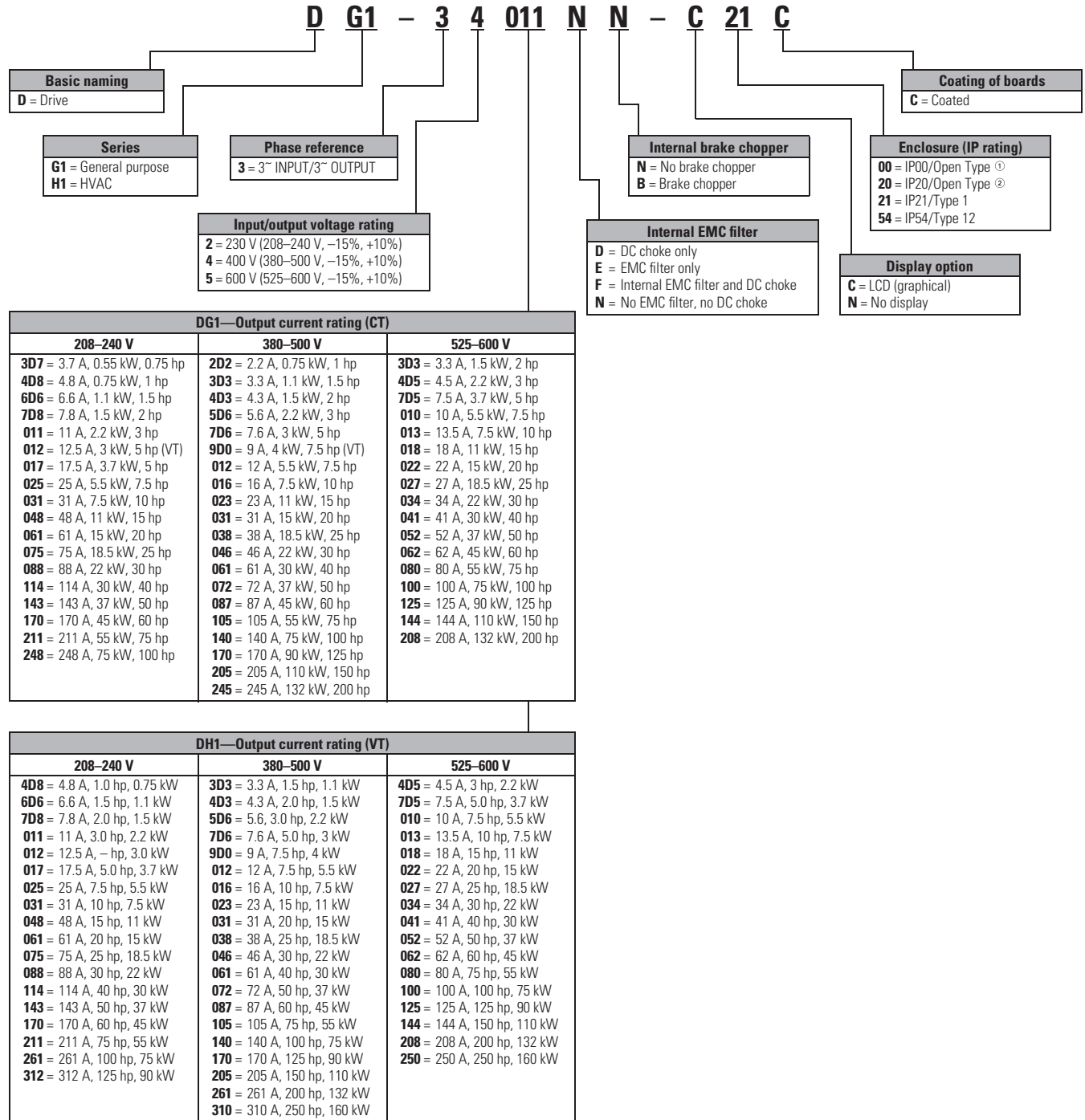

① IP00 FR7 and FR8 is not available for 230 V input product or with the PowerXL DH1 product.

② IP20 FRO will be available in June 2018 for the PowerXL DH1 product.

## Power ratings and product selection

### PowerXL Series drives—FR0, 208–240 Volt

Table 2. Open Type IP20

Frame size	Constant torque (CT)/high overload (I <sub>H</sub> )			Variable torque (VT)/low overload (I <sub>L</sub> )			DG1 Catalog number	DH1 Catalog number
	230 V, 50 Hz kW rating	230 V, 60 Hz hp	Current A	230 V, 50 Hz kW rating	230 V, 60 Hz hp	Current A		
FR0	0.55	0.75	3.7	0.75	1	4.8	DG1-323D7EB-C20C	DH1-324D8EB-C20C ①
	0.75	1	4.8	1.1	1.5	6.6	DG1-324D8EB-C20C	DH1-326D6EB-C20C ①
	1.1	1.5	6.6	1.5	2	7.8	DG1-326D6EB-C20C	DH1-327D8EB-C20C ①

① IP20 FR0 will be available in June 2018.

### PowerXL Series drives—FR1–FR6, 208–240 Volt

Table 3. Type 1/IP21

Frame size	Constant torque (CT)/high overload (I <sub>H</sub> )			Variable torque (VT)/low overload (I <sub>L</sub> )			DG1 Catalog number	DH1 Catalog number
	230 V, 50 Hz kW rating	230 V, 60 Hz hp	Current A	230 V, 50 Hz kW rating	230 V, 60 Hz hp	Current A		
FR1	0.55	0.75	3.7	0.75	1	4.8	DG1-323D7FB-C21C	DH1-324D8DN-C21C
	0.75	1	4.8	1.1	1.5	6.6	DG1-324D8FB-C21C	DH1-326D6DN-C21C
	1.1	1.5	6.6	1.5	2	7.8	DG1-326D6FB-C21C	DH1-327D8DN-C21C
	1.5	2	7.8	2.2	3	11	DG1-327D8FB-C21C	DH1-32011DN-C21C
	2.2	3	11	3	–	12.5	DG1-32011FB-C21C	DH1-32012DN-C21C
FR2	3	–	12.5	3.7	5	17.5	DG1-32012FB-C21C	DH1-32017DN-C21C
	3.7	5	17.5	5.5	7.5	25	DG1-32017FB-C21C	DH1-32025DN-C21C
	5.5	7.5	25	7.5	10	31	DG1-32025FB-C21C	DH1-32031DN-C21C
FR3	7.5	10	31	11	15	48	DG1-32031FB-C21C	DH1-32048DN-C21C
	11	15	48	15	20	61	DG1-32048FB-C21C	DH1-32061DN-C21C
FR4	15	20	61	18.5	25	75	DG1-32061FN-C21C	DH1-32075DN-C21C
	18.5	25	75	22	30	88	DG1-32075FN-C21C	DH1-32088DN-C21C
	22	30	88	30	40	114	DG1-32088FN-C21C	DH1-32114DN-C21C
FR5	30	40	114	37	50	143	DG1-32114FN-C21C	DH1-32143DN-C21C
	37	50	143	45	60	170	DG1-32143FN-C21C	DH1-32170DN-C21C
	45	60	170	55	75	211	DG1-32170FN-C21C	DH1-32211DN-C21C
FR6	55	75	211	75	100	261	DG1-32211FN-C21C	DH1-32261DN-C21C
	75	100	248	90	125	312	DG1-32248FN-C21C	DH1-32312DN-C21C



Table 4. Type 12/IP54

Frame size	Constant torque (CT)/high overload (I <sub>h</sub> )			Variable torque (VT)/low overload (I <sub>v</sub> )			DG1 Catalog number	DH1 Catalog number
	230 V, 50 Hz kW rating	230 V, 60 Hz hp	Current A	230 V, 50 Hz kW rating	230 V, 60 Hz hp	Current A		
FR1	0.55	0.75	3.7	0.75	1	4.8	DG1-323D7FB-C54C	DH1-324D8DN-C54C
	0.75	1	4.8	1.1	1.5	6.6	DG1-324D8FB-C54C	DH1-326D6DN-C54C
	1.1	1.5	6.6	1.5	2	7.8	DG1-326D6FB-C54C	DH1-327D8DN-C54C
	1.5	2	7.8	2.2	3	11	DG1-327D8FB-C54C	DH1-32011DN-C54C
	2.2	3	11	3	–	12.5	DG1-32011FB-C54C	DH1-32012DN-C54C
FR2	3	–	12.5	3.7	5	17.5	DG1-32012FB-C54C	DH1-32017DN-C54C
	3.7	5	17.5	5.5	7.5	25	DG1-32017FB-C54C	DH1-32025DN-C54C
	5.5	7.5	25	7.5	10	31	DG1-32025FB-C54C	DH1-32031DN-C54C
FR3	7.5	10	31	11	15	48	DG1-32031FB-C54C	DH1-32048DN-C54C
	11	15	48	15	20	61	DG1-32048FB-C54C	DH1-32061DN-C54C
FR4	15	20	61	18.5	25	75	DG1-32061FN-C54C	DH1-32075DN-C54C
	18.5	25	75	22	30	88	DG1-32075FN-C54C	DH1-32088DN-C54C
	22	30	88	30	40	114	DG1-32088FN-C54C	DH1-32114DN-C54C
FR5	30	40	114	37	50	143	DG1-32114FN-C54C	DH1-32143DN-C54C
	37	50	143	45	60	170	DG1-32143FN-C54C	DH1-32170DN-C54C
	45	60	170	55	75	211	DG1-32170FN-C54C	DH1-32211DN-C54C
FR6	55	75	211	75	100	261	DG1-32211FN-C54C	DH1-32261DN-C54C
	75	100	248	90	125	312	DG1-32248FN-C54C	DH1-32312DN-C54C

## PowerXL Series drives—FR0, 380–500 Volt

Table 5. Open Type IP20

Frame size	Constant torque (CT)/high overload (I <sub>h</sub> )			Variable torque (VT)/low overload (I <sub>v</sub> )			DG1 Catalog number	DH1 Catalog number
	480 V, 50 Hz kW rating	480 V, 60 Hz hp	Current A	480 V, 50 Hz kW rating	480 V, 60 Hz hp	Current A		
FR0	0.75	1	2.2	1.1	1.5	3.3	DG1-342D2EB-C20C	DH1-343D3EB-C20C ①
	1.1	1.5	3.3	1.5	2	4.6	DG1-343D3EB-C20C	DH1-344D3EB-C20C ①
	1.5	2	4.3	2.2	3	5.6	DG1-344D3EB-C20C	DH1-345D6EB-C20C ①
	2.2	3	5.6	3	5	7.6	DG1-345D6EB-C20C	DH1-347D6EB-C20C ①

① IP20 FR0 will be available in June 2018.

**PowerXL Series drives—FR1–FR6, 380–500 Volt**

**Table 6. Type 1/IP21**

Frame size	Constant torque (CT)/high overload (I <sub>H</sub> )			Variable torque (VT)/low overload (I <sub>L</sub> )			DG1 Catalog number	DH1 Catalog number
	400 V, 50 Hz kW rating	460 V, 60 Hz hp	Current A	400 V, 50 Hz kW rating	460 V, 60 Hz hp	Current A		
FR1	0.75	1	2.2	1.1	1.5	3.3	DG1-342D2FB-C21C	DH1-343D3DN-C21C
	1.1	1.5	3.3	1.5	2	4.3	DG1-343D3FB-C21C	DH1-344D3DN-C21C
	1.5	2	4.3	2.2	3	5.6	DG1-344D3FB-C21C	DH1-345D6DN-C21C
	2.2	3	5.6	3	5	7.6	DG1-345D6FB-C21C	DH1-347D6DN-C21C
	3	5	7.6	4	–	9	DG1-347D6FB-C21C	DH1-349D0DN-C21C
FR2	4	–	9	5.5	7.5	12	DG1-349D0FB-C21C	DH1-34012DN-C21C
	5.5	7.5	12	7.5	10	16	DG1-34012FB-C21C	DH1-34016DN-C21C
	7.5	10	16	11	15	23	DG1-34016FB-C21C	DH1-34023DN-C21C
	11	15	23	15	20	31	DG1-34023FB-C21C	DH1-34031DN-C21C
FR3	15	20	31	18.5	25	38	DG1-34031FB-C21C	DH1-34038DN-C21C
	18.5	25	38	22	30	46	DG1-34038FB-C21C	DH1-34046DN-C21C
	22	30	46	30	40	61	DG1-34046FB-C21C	DH1-34061DN-C21C
FR4	30	40	61	37	50	72	DG1-34061FN-C21C	DH1-34072DN-C21C
	37	50	72	45	60	87	DG1-34072FN-C21C	DH1-34087DN-C21C
	45	60	87	55	75	105	DG1-34087FN-C21C	DH1-34105DN-C21C
FR5	55	75	105	75	100	140	DG1-34105FN-C21C	DH1-34140DN-C21C
	75	100	140	90	125	170	DG1-34140FN-C21C	DH1-34170DN-C21C
	90	125	170	110	150	205	DG1-34170FN-C21C	DH1-34205DN-C21C
FR6	110	150	205	132	200	261	DG1-34205FN-C21C	DH1-34261DN-C21C
	132	200	245	160	250	310	DG1-34245FN-C21C	DH1-34310DN-C21C

**Table 7. Type 12/IP54**

Frame size	Constant torque (CT)/high overload (I <sub>H</sub> )			Variable torque (VT)/low overload (I <sub>L</sub> )			DG1 Catalog number	DH1 Catalog number
	400 V, 50 Hz kW rating	460 V, 60 Hz hp	Current A	400 V, 50 Hz kW rating	460 V, 60 Hz hp	Current A		
FR1	0.75	1	2.2	1.1	1.5	3.3	DG1-342D2FB-C54C	DH1-343D3DN-C54C
	1.1	1.5	3.3	1.5	2	4.3	DG1-343D3FB-C54C	DH1-344D3DN-C54C
	1.5	2	4.3	2.2	3	5.6	DG1-344D3FB-C54C	DH1-345D6DN-C54C
	2.2	3	5.6	3	5	7.6	DG1-345D6FB-C54C	DH1-347D6DN-C54C
	3	5	7.6	4	–	9	DG1-347D6FB-C54C	DH1-349D0DN-C54C
FR2	4	–	9	5.5	7.5	12	DG1-349D0FB-C54C	DH1-34012DN-C54C
	5.5	7.5	12	7.5	10	16	DG1-34012FB-C54C	DH1-34016DN-C54C
	7.5	10	16	11	15	23	DG1-34016FB-C54C	DH1-34023DN-C54C
	11	15	23	15	20	31	DG1-34023FB-C54C	DH1-34031DN-C54C
FR3	15	20	31	18.5	25	38	DG1-34031FB-C54C	DH1-34038DN-C54C
	18.5	25	38	22	30	46	DG1-34038FB-C54C	DH1-34046DN-C54C
	22	30	46	30	40	61	DG1-34046FB-C54C	DH1-34061DN-C54C
FR4	30	40	61	37	50	72	DG1-34061FN-C54C	DH1-34072DN-C54C
	37	50	72	45	60	87	DG1-34072FN-C54C	DH1-34087DN-C54C
	45	60	87	55	75	105	DG1-34087FN-C54C	DH1-34105DN-C54C
FR5	55	75	105	75	100	140	DG1-34105FN-C54C	DH1-34140DN-C54C
	75	100	140	90	125	170	DG1-34140FN-C54C	DH1-34170DN-C54C
	90	125	170	110	150	205	DG1-34170FN-C54C	DH1-34205DN-C54C
FR6	110	150	205	132	200	261	DG1-34205FN-C54C	DH1-34261DN-C54C
	132	200	245	160	250	310	DG1-34245FN-C54C	DH1-34310DN-C54C

## PowerXL Series drives—FR1–FR6, 600 Volt

Table 8. Type 1/IP21

Frame size	Constant torque (CT)/high overload ( $I_{H1}$ )			Variable torque (VT)/low overload ( $I_L$ )			DG1 Catalog number	DH1 Catalog number
	600 V, 50 Hz kW rating	600 V, 60 Hz hp	Current A	600 V, 50 Hz kW rating	600 V, 60 Hz hp	Current A		
FR1	1.5	2	3.3	2.2	3	4.5	DG1-353D3FB-C21C	DH1-354D5DN-C21C
	2.2	3	4.5	3.7	5	7.5	DG1-354D5FB-C21C	DH1-357D5DN-C21C
	3.7	5	7.5	5.5	7.5	10	DG1-357D5FB-C21C	DH1-35010DN-C21C
FR2	5.5	7.5	10	7.5	10	13.5	DG1-35010FB-C21C	DH1-35013DN-C21C
	7.5	10	13.5	11	15	18	DG1-35013FB-C21C	DH1-35018DN-C21C
	11	15	18	15	20	22	DG1-35018FB-C21C	DH1-35022DN-C21C
FR3	15	20	22	18.5	25	27	DG1-35022FB-C21C	DH1-35027DN-C21C
	18.5	25	27	22	30	34	DG1-35027FB-C21C	DH1-35034DN-C21C
	22	30	34	30	40	41	DG1-35034FB-C21C	DH1-35041DN-C21C
FR4	30	40	41	37	50	52	DG1-35041FN-C21C	DH1-35052DN-C21C
	37	50	52	45	60	62	DG1-35052FN-C21C	DH1-35062DN-C21C
	45	60	62	55	75	80	DG1-35062FN-C21C	DH1-35080DN-C21C
FR5	55	75	80	75	100	100	DG1-35080FN-C21C	DH1-35100DN-C21C
	75	100	100	90	125	125	DG1-35100FN-C21C	DH1-35125DN-C21C
	90	125	125	110	150	144	DG1-35125FN-C21C	DH1-35144DN-C21C
FR6	110	150	144	132	200	208	DG1-35144FN-C21C	DH1-35208DN-C21C
	132	200	208	160	250	250	DG1-35208FN-C21C	DH1-35250DN-C21C

Table 9. Type 12/IP54

Frame size	Constant torque (CT)/high overload ( $I_{H1}$ )			Variable torque (VT)/low overload ( $I_L$ )			DG1 Catalog number	DH1 Catalog number
	600 V, 50 Hz kW rating	600 V, 60 Hz hp	Current A	600 V, 50 Hz kW rating	600 V, 60 Hz hp	Current A		
FR1	1.5	2	3.3	2.2	3	4.5	DG1-353D3FB-C54C	DH1-354D5DN-C54C
	2.2	3	4.5	3.7	5	7.5	DG1-354D5FB-C54C	DH1-357D5DN-C54C
	3.7	5	7.5	5.5	7.5	10	DG1-357D5FB-C54C	DH1-35010DN-C54C
FR2	5.5	7.5	10	7.5	10	13.5	DG1-35010FB-C54C	DH1-35013DN-C54C
	7.5	10	13.5	11	15	18	DG1-35013FB-C54C	DH1-35018DN-C54C
	11	15	18	15	20	22	DG1-35018FB-C54C	DH1-35022DN-C54C
FR3	15	20	22	18.5	25	27	DG1-35022FB-C54C	DH1-35027DN-C54C
	18.5	25	27	22	30	34	DG1-35027FB-C54C	DH1-35034DN-C54C
	22	30	34	30	40	41	DG1-35034FB-C54C	DH1-35041DN-C54C
FR4	30	40	41	37	50	52	DG1-35041FN-C54C	DH1-35052DN-C54C
	37	50	52	45	60	62	DG1-35052FN-C54C	DH1-35062DN-C54C
	45	60	62	55	75	80	DG1-35062FN-C54C	DH1-35080DN-C54C
FR5	55	75	80	75	100	100	DG1-35080FN-C54C	DH1-35100DN-C54C
	75	100	100	90	125	125	DG1-35100FN-C54C	DH1-35125DN-C54C
	90	125	125	110	150	144	DG1-35125FN-C54C	DH1-35144DN-C54C
FR6	110	150	144	132	200	208	DG1-35144FN-C54C	DH1-35208DN-C54C
	132	200	208	160	250	250	DG1-35208FN-C54C	DH1-35250DN-C54C

## DG1 replacement parts

**Table 10. Frame 0**

Description	中文描述:	Catalog number 230 V	Catalog number 480 V	Catalog number 600 V
Standard keypad	DG1 标准键盘	DXG-KEY-LCD	DXG-KEY-LCD	—
Control module kit with keypad	DG1 控制模块及键盘套件	DXG-SPR-CTRLKIT	DXG-SPR-CTRLKIT	—
Control module kit without keypad	DG1 控制模块	DXG-SPR-CTRLBOARD	DXG-SPR-CTRLBOARD	—
Software kit (software, cable, manual)	DG1 软件套件 (软件, 线缆, 说明书)	DXG-ACC-SOFTWARE	DXG-ACC-SOFTWARE	—
Main power board	FR0 主功率板	DXG-SPR-2FROMPB	DXG-SPR-4FROMPB	—
Fan kit	FR0 风扇	DXG-SPR-FROFAN	DXG-SPR-FROFAN	—
IGBT module	IGBT 模块	DXG-SPR-2FROIGBT	DXG-SPR-4FROIGBT	—
EMC kit	EMC 套件	DXG-SPR-FROEMCKIT	DXG-SPR-FROEMCKIT	—

**Table 11. Frame 1**

Description	中文描述:	Catalog number 230 V	Catalog number 480 V	Catalog number 600 V
Standard keypad	DG1 标准键盘	DXG-KEY-LCD	DXG-KEY-LCD	DXG-KEY-LCD
Control module kit with keypad	DG1 控制模块及键盘套件	DXG-SPR-CTRLKIT	DXG-SPR-CTRLKIT	DXG-SPR-CTRLKIT
Control module kit without keypad	DG1 控制模块	DXG-SPR-CTRLBOARD	DXG-SPR-CTRLBOARD	DXG-SPR-CTRLBOARD
Software kit (software, cable, manual)	DG1 软件套件 (软件, 线缆, 说明书)	DXG-ACC-SOFTWARE	DXG-ACC-SOFTWARE	DXG-ACC-SOFTWARE
Type 1/IP21 standard cover	Type1/IP21 前面板	DXG-SPR-FR1CVR	DXG-SPR-FR1CVR	DXG-SPR-FR1CVR
EMI board	EMI 板	DXG-SPR-2FR1EB	DXG-SPR-4FR1EB	DXG-SPR-5FR1EB
Type 12/IP54 kit	Type12/IP54 套件	DXG-ACC-2FR1N12KIT	DXG-ACC-4FR1N12KIT	DXG-ACC-4FR1N12KIT
Main power board	FR1 主功率板	DXG-SPR-2FR1MPB	DXG-SPR-4FR1MPB	DXG-SPR-5FR1MPB
Control board cover		DXG-SPR-BCOVER	DXG-SPR-BCOVER	DXG-SPR-BCOVER
Main fan kit ①		DXG-SPR-FR1FAN	DXG-SPR-FR1FAN	DXG-SPR-FR1FAN
Control fan		DXG-SPR-2FR1CF	DXG-SPR-4FR1CF	DXG-SPR-4FR1CF
Middle chassis cover		DXG-SPR-FR1MCC	DXG-SPR-FR1MCC	DXG-SPR-FR1MCC
Outer housing		DXG-SPR-FR10H	DXG-SPR-FR10H	DXG-SPR-5FR10H
UL conduit plate		DXG-SPR-FR1CPUL	DXG-SPR-FR1CPUL	DXG-SPR-FR1CPUL
IEC conduit plate		DXG-SPR-FR1CPIEC	DXG-SPR-FR1CPIEC	DXG-SPR-FR1CPIEC
Type 12 grommet		DXG-SPR-FR1GRN12	DXG-SPR-FR1GRN12	DXG-SPR-FR1GRN12
Terminal block		DXG-SPR-2FR1TB	DXG-SPR-FR1TB	DXG-SPR-FR1TB

**Table 12. Frame 2**

Description	中文描述:	Catalog number 230 V	Catalog number 480 V	Catalog number 600 V
Standard Keypad	DG1 标准键盘	DXG-KEY-LCD	DXG-KEY-LCD	DXG-KEY-LCD
Control module kit with keypad	DG1 控制模块及键盘套件	DXG-SPR-CTRLKIT	DXG-SPR-CTRLKIT	DXG-SPR-CTRLKIT
Control module kit without keypad	DG1 控制模块	DXG-SPR-CTRLBOARD	DXG-SPR-CTRLBOARD	DXG-SPR-CTRLBOARD
Software kit (software, cable, manual)	DG1 软件套件 (软件, 线缆, 说明书)	DXG-ACC-SOFTWARE	DXG-ACC-SOFTWARE	DXG-ACC-SOFTWARE
Type 1/IP21 standard cover	Type1/IP21 前面板	DXG-SPR-FR2CVR	DXG-SPR-FR2CVR	DXG-SPR-FR2CVR
EMI board	EMI 板	DXG-SPR-2FR2EB	DXG-SPR-4FR2EB	DXG-SPR-5FR2EB
Type 12/IP54 kit	Type1/IP54 套件	DXG-ACC-FR2N12KIT	DXG-ACC-FR2N12KIT	DXG-ACC-FR2N12KIT
Main power board	FR1 主功率板	DXG-SPR-2FR2MPB	DXG-SPR-4FR2MPB	DXG-SPR-5FR2MPB
Control board cover		DXG-SPR-BCOVER	DXG-SPR-BCOVER	DXG-SPR-BCOVER

① Factory recommended spare parts.

Table 12. Frame 2, continued

Description	中文描述:	Catalog number 230 V	Catalog number 480 V	Catalog number 600 V
Main fan kit ①		DXG-SPR-FR2FAN	DXG-SPR-FR2FAN	DXG-SPR-FR2FAN
Control fan		DXG-SPR-FR2CF	DXG-SPR-FR2CF	DXG-SPR-FR2CF
Bus capacitor		DXG-SPR-2FR2BC	DXG-SPR-4FR24BC	DXG-SPR-5FR24BC
IGBT module		DXG-SPR-FR2IGBT	DXG-SPR-FR2IGBT	DXG-SPR-5FR2IGBT
Middle chassis cover		DXG-SPR-FR2MCC	DXG-SPR-FR2MCC	DXG-SPR-FR2MCC
Outer housing		DXG-SPR-FR20H	DXG-SPR-FR20H	DXG-SPR-5FR20H
UL conduit plate		DXG-SPR-FR2CPUL	DXG-SPR-FR2CPUL	DXG-SPR-FR2CPUL
IEC conduit plate		DXG-SPR-FR2CPIEC	DXG-SPR-FR2CPIEC	DXG-SPR-FR2CPIEC
Type 12 grommet		DXG-SPR-FR2GRN12	DXG-SPR-FR2GRN12	DXG-SPR-FR2GRN12
Terminal block		DXG-SPR-FR2TB	DXG-SPR-FR2TB	DXG-SPR-FR2TB

Table 13. Frame 3

Description	中文描述:	Catalog number 230 V	Catalog number 480 V	Catalog number 600 V
Standard keypad	DG1 标准键盘	DXG-KEY-LCD	DXG-KEY-LCD	DXG-KEY-LCD
Control module kit with keypad	DG1 控制模块及键盘套件	DXG-SPR-CTRLKIT	DXG-SPR-CTRLKIT	DXG-SPR-CTRLKIT
Control module kit without keypad	DG1 控制模块	DXG-SPR-CTRLBOARD	DXG-SPR-CTRLBOARD	DXG-SPR-CTRLBOARD
Software kit (software, cable, manual)	DG1 软件套件 (软件, 线缆, 说明书)	DXG-ACC-SOFTWARE	DXG-ACC-SOFTWARE	DXG-ACC-SOFTWARE
Type 1/IP21 standard cover	Type1/IP21 前面板	DXG-SPR-FR3CVR	DXG-SPR-FR3CVR	DXG-SPR-FR3CVR
EMI board	EMI 板	DXG-SPR-2FR3EB	DXG-SPR-4FR3EB	DXG-SPR-5FR3EB
Drive board	驱动板	DXG-SPR-2FR3DB	DXG-SPR-4FR3DB	DXG-SPR-5FR3DB
Main power board	FR1 主功率板	DXG-SPR-2FR3MPB	DXG-SPR-4FR3MPB	DXG-SPR-5FR3MPB
Control board cover		DXG-SPR-BCOVER	DXG-SPR-BCOVER	DXG-SPR-BCOVER
Main fan kit ①		DXG-SPR-FR3FANKIT	DXG-SPR-FR3FANKIT	DXG-SPR-FR3FANKIT
Main fan		DXG-SPR-FR3FAN	DXG-SPR-FR3FAN	DXG-SPR-FR3FAN
Control fan		DXG-SPR-FR34CF	DXG-SPR-FR34CF	DXG-SPR-FR34CF
Bus capacitor		DXG-SPR-FR3BC	DXG-SPR-FR3BC	DXG-SPR-5FR3BC
Output board		DXG-SPR-FR3OB	DXG-SPR-FR3OB	DXG-SPR-5FR3OB
Middle chassis cover		DXG-SPR-FR3MCC	DXG-SPR-FR3MCC	DXG-SPR-FR3MCC
Outer housing		DXG-SPR-FR30H	DXG-SPR-FR30H	DXG-SPR-FR30H
UL conduit plate		DXG-SPR-FR3CPUL	DXG-SPR-FR3CPUL	DXG-SPR-FR3CPUL
IEC conduit plate		DXG-SPR-FR3CPIEC	DXG-SPR-FR3CPIEC	DXG-SPR-FR3CPIEC
Type 12 grommet		DXG-SPR-FR3GRN12	DXG-SPR-FR3GRN12	DXG-SPR-FR3GRN12
Terminal block		DXG-SPR-FR3TB	DXG-SPR-FR3TB	DXG-SPR-FR3TB

Table 14. Frame 4

Description	中文描述:	Catalog number 230 V	Catalog number 480 V	Catalog number 600 V
Standard keypad	DG1 标准键盘	DXG-KEY-LCD	DXG-KEY-LCD	DXG-KEY-LCD
Control module kit with keypad	DG1 控制模块及键盘套件	DXG-SPR-CTRLKIT	DXG-SPR-CTRLKIT	DXG-SPR-CTRLKIT
Control module kit without keypad	DG1 控制模块	DXG-SPR-CTRLBOARD	DXG-SPR-CTRLBOARD	DXG-SPR-CTRLBOARD
Software kit (software, cable, manual)	DG1 软件套件 (软件, 线缆, 说明书)	DXG-ACC-SOFTWARE	DXG-ACC-SOFTWARE	DXG-ACC-SOFTWARE
Type 1/IP21 standard cover	Type1/IP21 前面板	DXG-SPR-FR4CVR	DXG-SPR-FR4CVR	DXG-SPR-FR4CVR
EMI board	EMI 板	DXG-SPR-4FR4EB	DXG-SPR-4FR4EB	DXG-SPR-5FR4EB

① Factory recommended spare parts.

**Table 14. Frame 4, continued**

<b>Description</b>	<b>中文描述:</b>	<b>Catalog number 230 V</b>	<b>Catalog number 480 V</b>	<b>Catalog number 600 V</b>
Softstart board	软启动电路板	DXG-SPR-2FR4SB	DXG-SPR-4FR4SB	DXG-SPR-5FR4SB
Main power board	FR1 主功率板	DXG-SPR-2FR4MPB	DXG-SPR-4FR4MPB	DXG-SPR-5FR4MPB
Control board cover		DXG-SPR-BCOVER	DXG-SPR-BCOVER	DXG-SPR-BCOVER
Main fan kit ①		DXG-SPR-FR4FANKIT	DXG-SPR-FR4FANKIT	DXG-SPR-FR4FANKIT
Main fan		DXG-SPR-FR4FAN	DXG-SPR-FR4FAN	DXG-SPR-FR4FAN
Control fan		DXG-SPR-FR34CF	DXG-SPR-FR34CF	DXG-SPR-FR34CF
Bus capacitor		DXG-SPR-2FR4BC	DXG-SPR-4FR24BC	DXG-SPR-5FR24BC
IGBT module		DXG-SPR-2FR4IGBT	DXG-SPR-4FR4IGBT	DXG-SPR-5FR4IGBT
Rectifier module		DXG-SPR-2FR4RM	DXG-SPR-4FR4RM	DXG-SPR-5FR4RM
Brake chopper module		DXG-SPR-2FR4BCM	DXG-SPR-4FR4BCM	DXG-SPR-5FR4BCM
Middle chassis cover		DXG-SPR-FR4MCC	DXG-SPR-FR4MCC	DXG-SPR-FR4MCC
Outer housing		DXG-SPR-FR40H	DXG-SPR-FR40H	DXG-SPR-5FR40H
UL conduit plate		DXG-SPR-FR4CPUL	DXG-SPR-FR4CPUL	DXG-SPR-FR4CPUL
IEC conduit plate		DXG-SPR-FR4CPIEC	DXG-SPR-FR4CPIEC	DXG-SPR-FR4CPIEC
Type 12 grommet		DXG-SPR-FR4GRN12	DXG-SPR-FR4GRN12	DXG-SPR-FR4GRN12
Terminal block		DXG-SPR-FR4TB	DXG-SPR-FR4TB	DXG-SPR-FR4TB

**Table 15. Frame 5**

<b>Description</b>	<b>中文描述:</b>	<b>Catalog number 230 V</b>	<b>Catalog number 480 V</b>	<b>Catalog number 600 V</b>
Standard keypad	DG1 标准键盘	DXG-KEY-LCD	DXG-KEY-LCD	DXG-KEY-LCD
Control module kit with keypad	DG1 控制模块及键盘套件	DXG-SPR-CTRLKIT	DXG-SPR-CTRLKIT	DXG-SPR-CTRLKIT
Control module kit without keypad	DG1 控制模块	DXG-SPR-CTRLBOARD	DXG-SPR-CTRLBOARD	DXG-SPR-CTRLBOARD
Software kit (software, cable, manual)	DG1 软件套件 (软件, 线缆, 说明书)	DXG-ACC-SOFTWARE	DXG-ACC-SOFTWARE	DXG-ACC-SOFTWARE
Type 1/IP21 standard cover	Type1/IP21 前面板	DXG-SPR-FR5CVR	DXG-SPR-FR5CVR	DXG-SPR-FR5CVR
EMI-1 board	EMI-1 板	DXG-SPR-2FR5E1B	DXG-SPR-4FR5E1B	DXG-SPR-5FR5E1B
Main power board	FR1 主功率板	DXG-SPR-2FR5MPB	DXG-SPR-4FR5MPB	DXG-SPR-5FR5MPB
Control board cover		DXG-SPR-BCOVER	DXG-SPR-BCOVER	DXG-SPR-BCOVER
Main fan kit ①		DXG-SPR-FR5FANKIT	DXG-SPR-FR5FANKIT	DXG-SPR-FR5FANKIT
Main fan		DXG-SPR-FR5FAN	DXG-SPR-FR5FAN	DXG-SPR-FR5FAN
Control fan		DXG-SPR-FR5CF	DXG-SPR-FR5CF	DXG-SPR-FR5CF
Bus capacitor		DXG-SPR-FR5BC	DXG-SPR-FR5BC	DXG-SPR-5FR5BC
EMI-2 board		DXG-SPR-2FR5E2B	DXG-SPR-4FR5E2B	DXG-SPR-5FR5E2B
EMI-3 board		DXG-SPR-FR5E3B	DXG-SPR-FR5E3B	N/A
IGBT module		DXG-SPR-FR5IGBT	DXG-SPR-FR5IGBT	DXG-SPR-5FR5IGBT
Rectifier module		DXG-SPR-2FR5RM	DXG-SPR-4FR5RM	DXG-SPR-5FR5RM
Brake chopper module		DXG-SPR-2FR5BCM	DXG-SPR-4FR5BCM	DXG-SPR-5FR5BCM
Middle chassis cover		DXG-SPR-FR5MCC	DXG-SPR-FR5MCC	DXG-SPR-FR5MCC
Outer housing		DXG-SPR-FR50H	DXG-SPR-FR50H	DXG-SPR-FR50H
UL conduit plate		DXG-SPR-FR5CPUL	DXG-SPR-FR5CPUL	DXG-SPR-FR5CPUL
IEC conduit plate		DXG-SPR-FR5IECCP	DXG-SPR-FR5IECCP	DXG-SPR-FR5IECCP
Type 12 grommet		DXG-SPR-FR5GRN12	DXG-SPR-FR5GRN12	DXG-SPR-FR5GRN12
Terminal block (1-pole)		DXG-SPR-FR5TB1P	DXG-SPR-FR5TB1P	DXG-SPR-FR5TB1P
Terminal block (3-pole)		DXG-SPR-FR5TB3P	DXG-SPR-FR5TB3P	DXG-SPR-FR5TB3P

① Factory recommended spare parts.

Table 16. Frame 6

Description	中文描述:	Catalog number 230 V	Catalog number 480 V	Catalog number 600 V
Standard keypad	DG1 标准键盘	DXG-KEY-LCD	DXG-KEY-LCD	DXG-KEY-LCD
Control module kit with keypad	DG1 控制模块及键盘套件	DXG-SPR-CTRLKIT	DXG-SPR-CTRLKIT	DXG-SPR-CTRLKIT
Control module kit without keypad	DG1 控制模块	DXG-SPR-CTRLBOARD	DXG-SPR-CTRLBOARD	DXG-SPR-CTRLBOARD
Software kit (software, cable, manual)	DG1 软件套件 (软件, 线缆, 说明书)	DXG-ACC-SOFTWARE	DXG-ACC-SOFTWARE	DXG-ACC-SOFTWARE
Main power board		DXG-SPR-2FR6MPB	DXG-SPR-4FR6MPB	DXG-SPR-5FR6MPB
Control board cover		DXG-SPR-BCOVER	DXG-SPR-BCOVER	DXG-SPR-BCOVER
Type 1/IP21 standard cover		DXG-SPR-FR6CVR	DXG-SPR-FR6CVR	DXG-SPR-FR6CVR
Main fan kit		DXG-SPR-FR6FANKIT	DXG-SPR-FR6FANKIT	DXG-SPR-FR6FANKIT
Control fan		DXG-SPR-FR6CF	DXG-SPR-FR6CF	DXG-SPR-FR6CF
Bus capacitor		DXG-SPR-FR6BC	DXG-SPR-FR6BC	DXG-SPR-5FR6BC
EMI board		DXG-SPR-FR6EB	DXG-SPR-FR6EB	DXG-SPR-FR6EB
Softstart board		DXG-SPR-2FR6SB	DXG-SPR-4FR6SB	DXG-SPR-5FR6SB
Rectifier snubber board		DXG-SPR-2FR6RSB	DXG-SPR-4FR6RSB	DXG-SPR-5FR6RSB
IGBT module with drive board		DXG-SPR-2FR6IGBT	DXG-SPR-4FR6IGBT	DXG-SPR-5FR6IGBT
Rectifier module		DXG-SPR-FR6RM	DXG-SPR-FR6RM	DXG-SPR-5FR6RM
Middle chassis cover		DXG-SPR-FR6MCC	DXG-SPR-FR6MCC	DXG-SPR-FR6MCC
Outer housing		DXG-SPR-FR60H	DXG-SPR-FR60H	DXG-SPR-FR60H
UL conduit plate		DXG-SPR-FR6CPUL	DXG-SPR-FR6CPUL	DXG-SPR-FR6CPUL
IEC conduit plate		DXG-SPR-FR6CPIEC	DXG-SPR-FR6CPIEC	DXG-SPR-FR6CPIEC
Type 12 grommet		DXG-SPR-FR6GRN12	DXG-SPR-FR6GRN12	DXG-SPR-FR6GRN12
Terminal block (1-pole)		DXG-SPR-FR6TB1P	DXG-SPR-FR6TB1P	DXG-SPR-FR6TB1P
Terminal block (3-pole)		DXG-SPR-FR6TB3P	DXG-SPR-FR6TB3P	DXG-SPR-FR6TB3P

## DH1 replacement parts

Table 17. Frame 0

Description	Catalog number 230 V	Catalog number 480 V	Catalog number 575 V
Standard keypad	DXH-KEY-LCD	DXH-KEY-LCD	—
Main control board	DXH-SPR-CTRLBOARD	DXH-SPR-CTRLBOARD	—
Control module kit with keypad	DXH-SPR-CTRLKIT	DXH-SPR-CTRLKIT	—
Main fan kit	DXG-SPR-FR0FAN	DXG-SPR-FR0FAN	—
Main power board	DXG-SPR-2FR0MPB	DXG-SPR-4FR0MPB	—
EMI kit for C2	DXG-SPR-FR0EMCKIT	DXG-SPR-FR0EMCKIT	—

**Table 18. Frame 1**

<b>Description</b>	<b>Catalog number 230 V</b>	<b>Catalog number 480 V</b>	<b>Catalog number 575 V</b>
Standard keypad	DXH-KEY-LCD	DXH-KEY-LCD	DXH-KEY-LCD
Control module kit with keypad	DXH-SPR-CTRLKIT	DXH-SPR-CTRLKIT	DXH-SPR-CTRLKIT
Main control board	DXH-SPR-CTRLBOARD	DXH-SPR-CTRLBOARD	DXH-SPR-CTRLBOARD
Standard cover	DXH-SPR-FR1CVR	DXH-SPR-FR1CVR	DXH-SPR-FR1CVR
EMI board	DXG-SPR-2FR1EB	DXG-SPR-4FR1EB	DXG-SPR-5FR1EB
Type 12/IP54 kit	DXH-ACC-2FR1N12KIT	DXH-ACC-4FR1N12KIT	DXH-ACC-4FR1N12KIT
Main power board	DXH-SPR-2FR1MPB	DXH-SPR-4FR1MPB	DXG-SPR-5FR1MPB
Control board cover	DXG-SPR-BCOVER	DXG-SPR-BCOVER	DXG-SPR-BCOVER
Main fan kit	DXG-SPR-FR1FAN	DXG-SPR-FR1FAN	DXG-SPR-FR1FAN
Control fan	DXG-SPR-2FR1CF	DXG-SPR-4FR1CF	DXG-SPR-4FR1CF
Middle chassis cover	DXG-SPR-FR1MCC	DXG-SPR-FR1MCC	DXG-SPR-FR1MCC
Outer housing	DXG-SPR-FR10H	DXG-SPR-FR10H	DXG-SPR-FR10H
UL conduit plate	DXG-SPR-FR1CPUL	DXG-SPR-FR1CPUL	DXG-SPR-FR1CPUL
IEC conduit plate	DXG-SPR-FR1CPIEC	DXG-SPR-FR1CPIEC	DXG-SPR-FR1CPIEC

**Table 19. Frame 2**

<b>Description</b>	<b>Catalog number 230 V</b>	<b>Catalog number 480 V</b>	<b>Catalog number 575 V</b>
Standard keypad	DXH-KEY-LCD	DXH-KEY-LCD	DXH-KEY-LCD
Control module kit with keypad	DXH-SPR-CTRLKIT	DXH-SPR-CTRLKIT	DXH-SPR-CTRLKIT
Main control board	DXH-SPR-CTRLBOARD	DXH-SPR-CTRLBOARD	DXH-SPR-CTRLBOARD
Standard cover	DXH-SPR-FR2CVR	DXH-SPR-FR2CVR	DXH-SPR-FR2CVR
EMI board	DXG-SPR-2FR2EB	DXG-SPR-4FR2EB	DXG-SPR-5FR2EB
Type 12/IP54 kit	DXH-ACC-FR2N12KIT	DXH-ACC-FR2N12KIT	DXH-ACC-FR2N12KIT
Main power board	DXH-SPR-2FR2MPB	DXH-SPR-4FR2MPB	DXG-SPR-5FR2MPB
Control board cover	DXG-SPR-BCOVER	DXG-SPR-BCOVER	DXG-SPR-BCOVER
Main fan kit	DXG-SPR-FR2FAN	DXG-SPR-FR2FAN	DXG-SPR-FR2FAN
Control fan	DXG-SPR-FR2CF	DXG-SPR-FR2CF	DXG-SPR-FR2CF
Bus capacitor	DXG-SPR-2FR2BC	DXG-SPR-4FR24BC	DXG-SPR-4FR24BC
Middle chassis cover	DXG-SPR-FR2MCC	DXG-SPR-FR2MCC	DXG-SPR-FR2MCC
Outer housing	DXG-SPR-FR20H	DXG-SPR-FR20H	DXG-SPR-FR20H
UL conduit plate	DXG-SPR-FR2CPUL	DXG-SPR-FR2CPUL	DXG-SPR-FR2CPUL
IEC conduit plate	DXG-SPR-FR2CPIEC	DXG-SPR-FR2CPIEC	DXG-SPR-FR2CPIEC

**Table 20. Frame 3**

<b>Description</b>	<b>Catalog number 230 V</b>	<b>Catalog number 480 V</b>	<b>Catalog number 575 V</b>
Standard keypad	DXH-KEY-LCD	DXH-KEY-LCD	DXH-KEY-LCD
Control module kit with keypad	DXH-SPR-CTRLKIT	DXH-SPR-CTRLKIT	DXH-SPR-CTRLKIT
Main control board	DXH-SPR-CTRLBOARD	DXH-SPR-CTRLBOARD	DXH-SPR-CTRLBOARD
Standard cover	DXH-SPR-FR3CVR	DXH-SPR-FR3CVR	DXH-SPR-FR3CVR
EMI board	DXG-SPR-2FR3EB	DXG-SPR-4FR3EB	DXG-SPR-5FR3EB
Control board cover	DXG-SPR-BCOVER	DXG-SPR-BCOVER	DXG-SPR-BCOVER
Main fan kit	DXG-SPR-FR3FANKIT	DXG-SPR-FR3FANKIT	DXG-SPR-FR3FANKIT



**Table 20. Frame 3, continued**

<b>Description</b>	<b>Catalog number 230 V</b>	<b>Catalog number 480 V</b>	<b>Catalog number 575 V</b>
Main fan	DXG-SPR-FR3FAN	DXG-SPR-FR3FAN	DXG-SPR-FR3FAN
Control fan	DXG-SPR-FR34CF	DXG-SPR-FR34CF	DXG-SPR-FR34CF
Bus capacitor	DXG-SPR-FR3BC	DXG-SPR-FR3BC	DXG-SPR-FR3BC
Middle chassis cover	DXG-SPR-FR3MCC	DXG-SPR-FR3MCC	DXG-SPR-FR3MCC
Outer housing	DXG-SPR-FR30H	DXG-SPR-FR30H	DXG-SPR-FR30H
UL conduit plate	DXG-SPR-FR3CPUL	DXG-SPR-FR3CPUL	DXG-SPR-FR3CPUL
IEC conduit plate	DXG-SPR-FR3CPIEC	DXG-SPR-FR3CPIEC	DXG-SPR-FR3CPIEC
Drive board	DXH-SPR-2FR3DB	DXH-SPR-4FR3DB	DXG-SPR-5FR3DB
Output board	DXG-SPR-4FR30B	DXG-SPR-4FR30B	DXG-SPR-5FR30B

**Table 21. Frame 4**

<b>Description</b>	<b>Catalog number 230 V</b>	<b>Catalog number 480 V</b>	<b>Catalog number 575 V</b>
Standard keypad	DXH-KEY-LCD	DXH-KEY-LCD	DXH-KEY-LCD
Control module kit with keypad	DXH-SPR-CTRLKIT	DXH-SPR-CTRLKIT	DXH-SPR-CTRLKIT
Main control board	DXH-SPR-CTRLBOARD	DXH-SPR-CTRLBOARD	DXH-SPR-CTRLBOARD
Standard cover	DXH-SPR-FR4CVR	DXH-SPR-FR4CVR	DXH-SPR-FR4CVR
EMI board	DXG-SPR-2FR4EB	DXG-SPR-4FR4EB	DXG-SPR-5FR4EB
Main power board	DXH-SPR-2FR4MPB	DXH-SPR-4FR4MPB	DXG-SPR-5FR4MPB
Control board cover	DXG-SPR-BCOVER	DXG-SPR-BCOVER	DXG-SPR-BCOVER
Main fan kit	DXG-SPR-FR4FANKIT	DXG-SPR-FR4FANKIT	DXG-SPR-FR4FANKIT
Main fan	DXG-SPR-FR4FAN	DXG-SPR-FR4FAN	DXG-SPR-FR4FAN
Control fan	DXG-SPR-FR34CF	DXG-SPR-FR34CF	DXG-SPR-FR34CF
Bus capacitor	DXG-SPR-2FR4BC	DXG-SPR-4FR24BC	DXG-SPR-4FR24BC
Middle chassis cover	DXG-SPR-FR4MCC	DXG-SPR-FR4MCC	DXG-SPR-FR4MCC
Outer housing	DXG-SPR-FR40H	DXG-SPR-FR40H	DXG-SPR-FR40H
UL conduit plate	DXG-SPR-FR4CPUL	DXG-SPR-FR4CPUL	DXG-SPR-FR4CPUL
IEC conduit plate	DXG-SPR-FR4CPIEC	DXG-SPR-FR4CPIEC	DXG-SPR-FR4CPIEC
Softstart board	DXH-SPR-2FR4SB	DXH-SPR-4FR4SB	DXG-SPR-5FR4SB
IGBT Module	DXG-SPR-2FR4IGBT	DXG-SPR-4FR4IGBT	DXG-SPR-4FR4IGBT
Rectifier module	DXG-SPR-2FR4RM	DXG-SPR-4FR4RM	DXG-SPR-4FR4RM
Brake chopper module	DXG-SPR-2FR4BCM	DXG-SPR-4FR4BCM	DXG-SPR-4FR4BCM

**Table 22. Frame 5**

<b>Description</b>	<b>Catalog number 230 V</b>	<b>Catalog number 480 V</b>	<b>Catalog number 575 V</b>
Standard keypad	DXH-KEY-LCD	DXH-KEY-LCD	DXH-KEY-LCD
Control module kit with keypad	DXH-SPR-CTRLKIT	DXH-SPR-CTRLKIT	DXH-SPR-CTRLKIT
Main control board	DXH-SPR-CTRLBOARD	DXH-SPR-CTRLBOARD	DXH-SPR-CTRLBOARD
Standard cover	DXH-SPR-FR5CVR	DXH-SPR-FR5CVR	DXH-SPR-FR5CVR
EMI-1 board	DXG-SPR-2FR5E1B	DXG-SPR-4FR5E1B	DXG-SPR-4FR5E1B
EMI-2 board	DXG-SPR-2FR5E2B	DXG-SPR-4FR5E2B	DXG-SPR-4FR5E2B
EMI-3 board	DXG-SPR-FR5E3B	DXG-SPR-FR5E3B	DXG-SPR-FR5E3B
Main power board	DXH-SPR-2FR5MPB	DXH-SPR-4FR5MPB	DXG-SPR-5FR5MPB
Control board cover	DXG-SPR-BCOVER	DXG-SPR-BCOVER	DXG-SPR-BCOVER

**Table 22. Frame 5, continued**

<b>Description</b>	<b>Catalog number 230 V</b>	<b>Catalog number 480 V</b>	<b>Catalog number 575 V</b>
Main fan kit	DXG-SPR-FR5FANKIT	DXG-SPR-FR5FANKIT	DXG-SPR-FR5FANKIT
Main fan	DXG-SPR-FR5FAN	DXG-SPR-FR5FAN	DXG-SPR-FR5FAN
Control fan	DXG-SPR-FR5CF	DXG-SPR-FR5CF	DXG-SPR-FR5CF
Bus capacitor	DXG-SPR-FR5BC	DXG-SPR-FR5BC	DXG-SPR-FR5BC
Middle chassis cover	DXG-SPR-FR5MCC	DXG-SPR-FR5MCC	DXG-SPR-FR5MCC
Outer housing	DXG-SPR-FR5OH	DXG-SPR-FR5OH	DXG-SPR-FR5OH
UL conduit plate	DXG-SPR-FR5CPUL	DXG-SPR-FR5CPUL	DXG-SPR-FR5CPUL
IEC conduit plate	DXG-SPR-FR5IECCP	DXG-SPR-FR5IECCP	DXG-SPR-FR5IECCP
IGBT Module	DXG-SPR-2FR5IGBT	DXG-SPR-4FR5IGBT	DXG-SPR-5FR5IGBT
Rectifier module	DXG-SPR-FR5RM	DXG-SPR-FR5RM	DXG-SPR-5FR5RM
Brake chopper module	DXG-SPR-2FR5BCM	DXG-SPR-4FR5BCM	DXG-SPR-4FR5BCM
DC terminal kit	DXG-SPR-FR5DCKIT	DXG-SPR-FR5DCKIT	DXG-SPR-FR5DCKIT

**Table 23. Frame 6**

<b>Description</b>	<b>Catalog number 230 V</b>	<b>Catalog number 480 V</b>	<b>Catalog number 575 V</b>
Standard keypad	DXH-KEY-LCD	DXH-KEY-LCD	DXH-KEY-LCD
Control module kit with keypad	DXH-SPR-CTRLKIT	DXH-SPR-CTRLKIT	DXH-SPR-CTRLKIT
Main control board	DXH-SPR-CTRLBOARD	DXH-SPR-CTRLBOARD	DXH-SPR-CTRLBOARD
Standard cover	DXH-SPR-FR6CVR	DXH-SPR-FR6CVR	DXH-SPR-FR6CVR
EMI board	DXG-SPR-FR6EB	DXG-SPR-FR6EB	DXG-SPR-FR6EB
Main power board	DXG-SPR-2FR6MPB	DXG-SPR-4FR6MPB	DXG-SPR-5FR6MPB
Control board cover	DXG-SPR-BCOVER	DXG-SPR-BCOVER	DXG-SPR-BCOVER
Main fan kit	DXG-SPR-FR6FANKIT	DXG-SPR-FR6FANKIT	DXG-SPR-FR6FANKIT
Main fan	DXG-SPR-FR6FAN	DXG-SPR-FR6FAN	DXG-SPR-FR6FAN
Control fan	DXG-SPR-FR6CF	DXG-SPR-FR6CF	DXG-SPR-FR6CF
Bus capacitor	DXG-SPR-FR6BC	DXG-SPR-FR6BC	DXG-SPR-FR6BC
Middle chassis cover	DXG-SPR-FR6MCC	DXG-SPR-FR6MCC	DXG-SPR-FR6MCC
Outer housing	DXG-SPR-FR6OH	DXG-SPR-FR6OH	DXG-SPR-FR6OH
UL conduit plate	DXG-SPR-FR6CPUL	DXG-SPR-FR6CPUL	DXG-SPR-FR6CPUL
IEC conduit plate	DXG-SPR-FR6CPIEC	DXG-SPR-FR6CPIEC	DXG-SPR-FR6CPIEC
IGBT Module	DXG-SPR-2FR6IGBT	DXG-SPR-4FR6IGBT	DXG-SPR-5FR6IGBT
Rectifier module	DXG-SPR-FR6RM	DXG-SPR-FR6RM	DXG-SPR-FR6RM
Type 12 grommet kit	DXG-SPR-FR6GRN12	DXG-SPR-FR6GRN12	DXG-SPR-FR6GRN12
Softstart board	DXG-SPR-2FR6SB	DXG-SPR-4FR6SB	DXG-SPR-5FR6SB
Rectifier snubber board	DXG-SPR-2FR6RSB	DXG-SPR-4FR6RSB	DXG-SPR-5FR6RSB
Terminal block kit (1-pole)	DXG-SPR-FR6TB1P	DXG-SPR-FR6TB1P	DXG-SPR-FR6TB1P
Terminal block kit (3-pole)	DXG-SPR-FR6TB3P	DXG-SPR-FR6TB3P	DXG-SPR-FR6TB3P

## Chapter 2—Engineering considerations

### Introduction

This chapter describes the most important features in the energy circuit of a drive system that you should take into consideration in your project planning.

**Figure 7. Drive system (PDS = power drive system)**

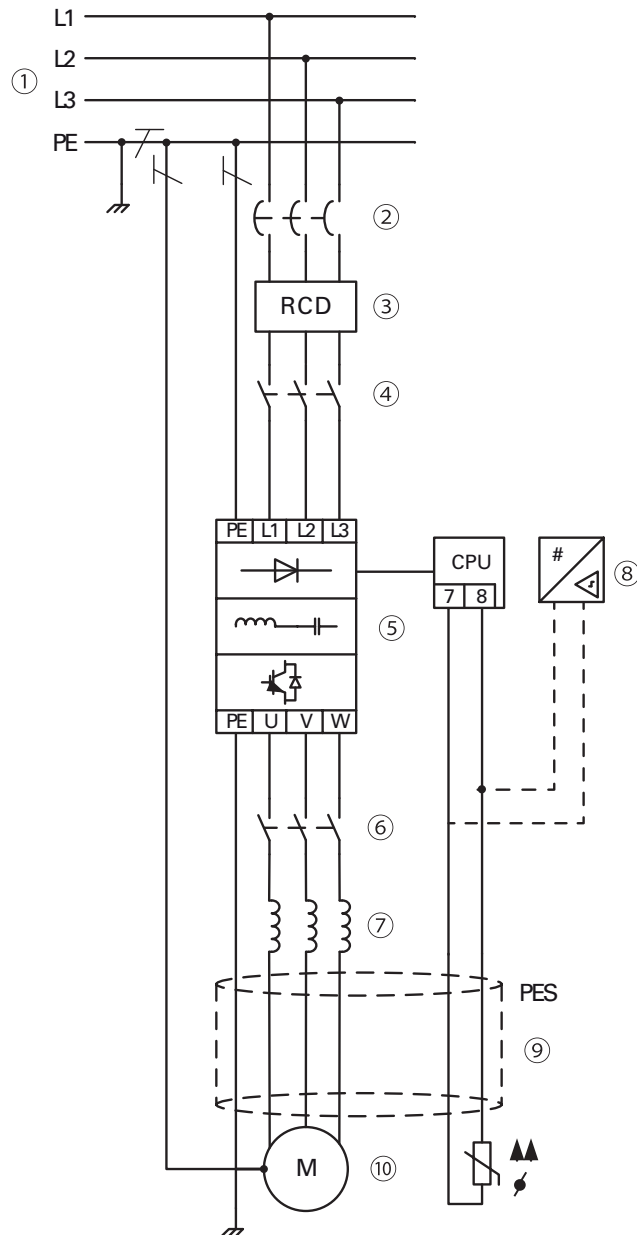

**Table 24. Drive system components**

Item no.	Description
1	Power grid configuration, input voltage, input frequency, interactions with PF correction systems
2	Breakers, fuses, cable cross-sections
3	Protection of persons and animals with residual-current protective devices
4	Input contactor, disconnecter
5	Frequency inverter: mounting, installation; power connection; EMC measures; circuit examples
6	Output contactor, disconnecter
7	Output reactor, dV/dT filter, sine-wave filter
8	Motor protection; thermistor (can be connected to drive directly)
9	Cable lengths, motor cables, shielding (EMC)
10	Motor and application, parallel operation of multiple motors on a VFD, bypass circuit, DC braking

## Electrical power network

### Input connection and configuration

The PowerXL Series frequency inverters can be connected and operated with all control-point grounded AC power networks (see IEC 60364 for more information).

**Figure 8. AC power networks with grounded neutral point (TN-/TT networks)**

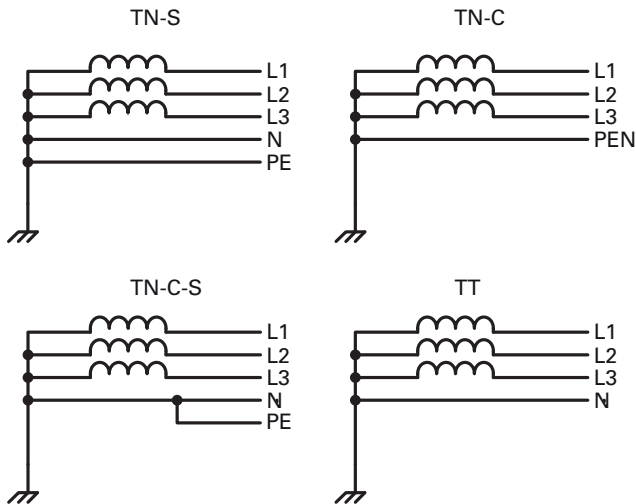

The frequency inverter can be applied to all types of power networks above. If multiple frequency inverters with single-phase supplies are to be connected, a symmetrical distribution to the three external conductors shall be taken into account. In addition, the total current of all single-phase consumers is not to cause an overload of the neutral conductor (N-conductor).

The connection and operation of frequency inverters to asymmetrically grounded TN networks (phase-grounded delta network “Grounded Delta”; USA) or neutral point ungrounded or high-resistance grounded (>30 ohms) IT networks is only conditionally permissible. In these networks above-mentioned, the internal interference suppression filter of frequency inverter must be disconnected (unscrew the screw marked ‘EMC’; see “Installation in IT System” on **Page 53**). Then the required filtering for EMC (electromagnetic compatibility) is no longer present (degrade to Class T).

Measures for EMC are mandatory in a drive system in order to meet the legal requirements for EMC and low voltage regulations.

Good grounding measures are a prerequisite for the effective insert of further measures such as shielding of filters. Without respective grounding measures, further steps are superfluous.

## Input voltage and frequency

The standardized input voltages (IEC 60038, VDE017-1) for energy suppliers (EVU) guarantee the following conditions at the transition points:

- Deviation from the rated value of voltage: Max.  $\pm 10\%$
- Deviation in voltage phase balance: Max.  $\pm 3\%$
- Deviation from rated value of the frequency: Max.  $\pm 4\%$

The board tolerance band of the PowerXL Series frequency inverter considers the rated value for

European as (EU:  $U_{LN} = 230\text{ V}/400\text{ V}$ , 50 Hz), American as (USA:  $U_{LN} = 240\text{ V}/480\text{ V}$ , 60 Hz) and Canada as (CAN:  $U_{LN} = 600\text{ V}$ , 60 Hz) standard voltages:

- 230 V, 50 Hz (EU) and 240 V, 60 Hz (USA) at DG1/DH1-32\_
- 400 V, 50 Hz (EU) and 480 V, 60 Hz (USA) at DG1/DH1-34\_
- 600 V, 60 Hz (CAN) at DG1/DH1-35\_

For the bottom voltage value, the permitted voltage drop of 4% in the consumer circuits is also taken into account, therefore a total of  $U_{LN} - 14\%$ .

- 230 V device class (DG1/DH1-32\_): 208 V  $-15\%$  to 240 V  $+10\%$  (177 V  $-0\%$  to 264 V  $+0\%$ )
- 400 V device class (DG1/DH1-34\_): 380 V  $-15\%$  to 500 V  $+10\%$  (323 V  $-0\%$  to 550 V  $+0\%$ )
- 600 V device class (DG1/DH1-35\_): 525 V  $-15\%$  to 600 V  $+10\%$  (446 V  $-0\%$  to 660 V  $+0\%$ )

The permitted frequency range is 50/60 Hz (45 Hz  $-0\%$  to 66 Hz  $+0\%$ ).

## Input voltage balance

Due to the uneven loading on the conductor, and with the direct connection of greater power ratings, deviations from the ideal voltage form and asymmetrical voltages can be caused in three-phase AC power networks. These asymmetric divergences in the input voltage can lead to different loading of the diodes in input rectifiers with three-phase supplied frequency inverters, and as a result, an advance failure of this diode.

In the project planning for the connection of three-phase supplied frequency inverters, consider only AC power networks that handle permitted asymmetric divergences in the input voltage  $\leq +3\%$ .

If this condition is not fulfilled, or symmetry at the connection location is uncertain, the use of an assigned AC choke is recommended.

### Total harmonic distortion (THD)

Non-linear consumers (loads) in an AC supply system produce harmonic voltages that again result in harmonic currents. These harmonic currents at the inductive and capacitive reactances of a mains supply system produce additional voltage drops with different values that are then overlaid on the sinusoidal mains voltage and result in distortions. In supply systems, this form of “noise” can give rise to problems in an installation if the sum of the harmonics exceeds certain limit values.

Non-linear consumers (harmonics producers) include for example:

- Induction and arc furnaces, welding devices
- Current converters, rectifiers and inverters, soft starters, variable frequency drives
- Switched-mode power supply units (computers, monitors, lighting), uninterruptible power supply (UPS)

The THD value (THD = Total Harmonic Distortion) is defined in standard IEC/EN 61800-3 as the ratio of the rms value of all harmonic components to the rms value of the fundamental frequency. It is given in percent of the total value.

$$\text{THD} = \frac{\sqrt{U_2^2 + U_3^2 + U_4^2 + \dots + U_n^2}}{U_1} \times 100\%$$

$U_1$  — *fundamental component*

$U_n$  — *n<sup>th</sup> order harmonic component*

The THD value of the harmonic distortion is stated in relation to the rms value of the total signal as a percentage. On a variable frequency drive, the total harmonic distortion is around 28–36%.

To assist in the calculation of system harmonics, a Harmonic Estimation Calculator Tool is available at [www.eaton.com/drives](http://www.eaton.com/drives).

### Reactive power compensation devices

Special compensation measures on the power supply side is not required for PowerXL Series drives, which take on very little reactive power of the fundamental harmonics from the AC power supply network ( $\cos\phi \sim 0.98$ ).

In the AC power networks with non-choked reactive current compensation devices, current deviations can enable parallel resonance and undefinable circumstances.

In the project planning for the connection of frequency inverters to AC power networks with undefined circumstances, please consider using AC chokes.

## Chapter 3—Product overview

### Component identification

Figure 9. Description of the PowerXL Series

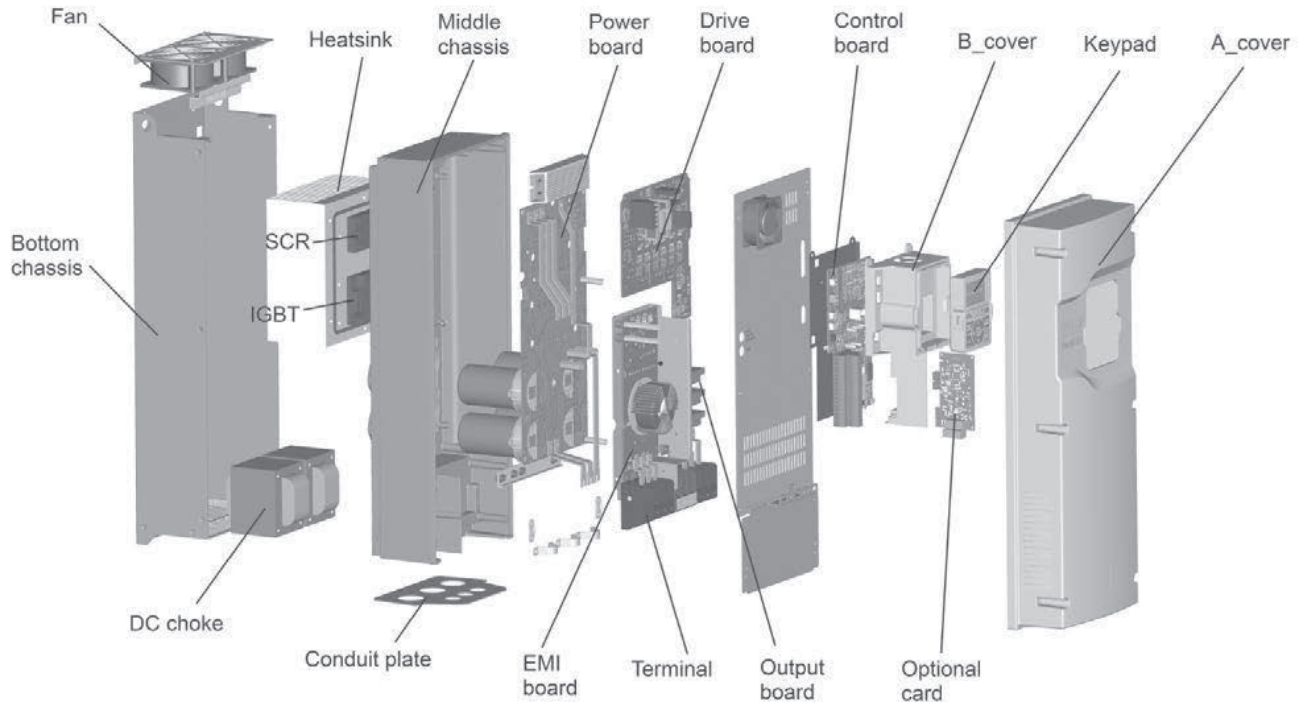

### Features

The PowerXL frequency inverter converts the voltage and frequency of an existing AC network into a DC voltage. This DC voltage is used to generate a three-phase AC voltage with adjustable frequency and assigned amplitude values for the variable speed control of three-phase asynchronous motors.

Figure 10. Block diagram, elements of PowerXL frequency inverters

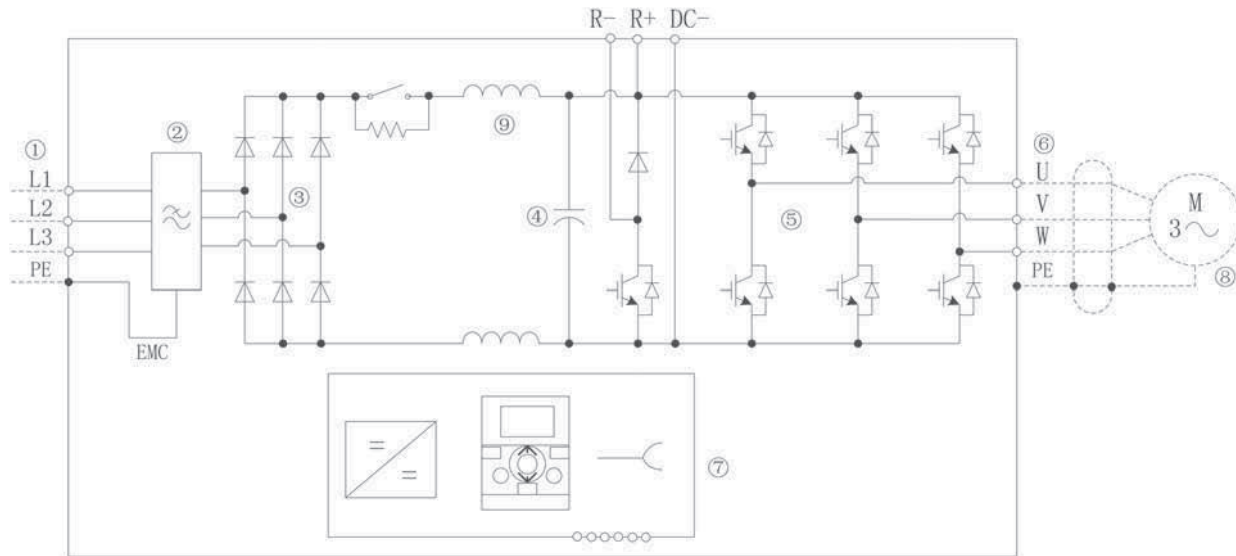

Table 25. Elements of PowerXL frequency inverters

Item no.	Description
1	Supply L1, L2 L3, PE, input supply voltage $U_{LN} = U_e$ at 50/60 Hz: D_1-32: 230 V class, three-phase input connection (3 AC 230 V/240 V) D_1-34: 400 V class, three-phase input connection (3 AC 400 V/480 V) D_1-35: 600 V class, three-phase input connection (3 AC 600 V)
2	Internal interference suppression filter, category C2 to IEC/EN 61800-3 EMC-connection of internal interference suppression filter to PE
3	Rectifier bridge, converts the AC voltage of the electrical network into DC voltage
4	DC link with charging resistor, capacitor and switching mode power supply unit (SMPS = Switching Mode Power Supply): DC link voltage UDC with three-phase input connection (3 AC): $U_{DC} = 1.41 \times U_{LN}$
5	Inverter. The IGBT based inverter converts the DC voltage of the DC link (UDC) into a three-phase AC voltage ( $U_2$ ) with variable amplitude and frequency ( $f_2$ ). Sinusoidal pulse width modulation (PWM) with V/f control can be switched to speed control with slip compensation
6	Motor connection U/T1, V/T2, W/T3 with output voltage $U_2$ (0–100% $U_e$ ) and output frequency $f_2$ (0–400 Hz) output current ( $I_2$ ): D_1-32: 3.7 A to 248 A D_1-34: 2.2 A to 245 A D_1-35: 3.3 A to 208 A 100% at an ambient temperature of 122 °F (50 °C) with an overload capacity of 150% for 60 s every 600 s and a starting current of 200% for 2 s every 20 s
7	Keypad with control buttons, graphic display, control voltage, control signal terminals, micro-switches, and interface for the PC interface module (option)
8	Three-phase asynchronous motor, variable speed control of three-phase asynchronous motor for assigned motor shaft power values ( $P_2$ ): D_1-32: 0.55 kW to 75 kW (230 V, 50 Hz) or 0.75 hp to 100 hp (240 V, 60 Hz) D_1-34: 0.75 kW to 132 kW (400 V, 50 Hz) or 1 hp to 200 hp (460 V, 60 Hz) D_1-35: 1.5 kW to 132 kW (600 V, 50 Hz) or 2 hp to 200 hp (600 V, 60 Hz)
9	DC link—chokes, to minimize current harmonics

## Selection criteria

The frequency inverter **[3]** is selected according to the supply voltage  $U_{LN}$  of the input supply **[1]** and the rated current of the assigned motor **[2]**. The circuit type ( $\Delta/Y$ ) of the motor must be selected according to the supply voltage **[1]**. The rated output current  $I_o$  of the frequency inverter must be greater than/equal to the rated motor current.

Figure 11. Selection criteria

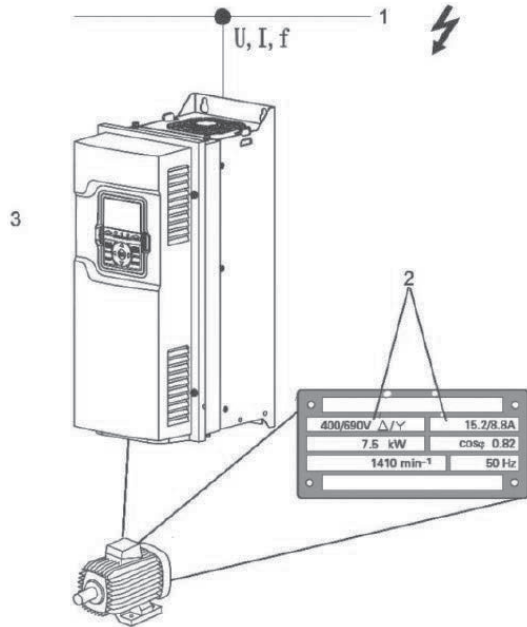

When selecting the drive, the following criteria must be known:

- Type of motor (three-phase asynchronous motor)
- Input voltage = rated operating voltage of the motor (for example, 3 AC ~400 V)
- Rated motor current (guide value, dependent on the circuit type and the supply voltage)
- Load torque (quadratic, constant)
- Starting torque
- Ambient temperature (rated value 122 °F [50 °C])

When connecting multiple motors in parallel to the output of a frequency inverter, the motor currents are added geometrically—separated by effective and idle current components. When you select a frequency inverter, make sure that it can supply the total resulting current. If necessary, for dampening and compensating the deviating current values, motor reactors or sinusoidal filters must be connected between the frequency inverter and the motor.

The parallel connection of multiple motors in the output of the frequency inverter is only permitted with V/Hz characteristic curve control.

If you connect a motor to an operational frequency inverter, the motor draws a multiple of its rated operational current. When you select a frequency inverter, make sure that the starting current plus the sum of the currents of the running motors will not exceed the rated output current of the frequency inverter.

Switching in the output of the frequency inverter is only permitted with V/Hz characteristic curve control.

## Proper use

The PowerXL frequency inverters are electrical apparatus for controlling variable speed drives with three-phase motors. They are designed for installation in machines or for use in combination with other components within a machine or system.

After installation in a machine, the frequency inverters must not be taken into operation until the associated machine has been confirmed to comply with the safety requirements of Machinery Safety Directive (MSD) 2006/42 EC (meets the requirements of EN 60204). The user of the equipment is responsible for ensuring that the machine use complies with the relevant EU Directives.

The CE markings on the PowerXL frequency inverter confirm that, when used in a typical drive configuration, the apparatus complies with the European Low Voltage Directive (LVD) and the EMC Directives (Directive 2014/35/EU and Directive 2014/30/EU).

In the described system configurations, PowerXL frequency inverters are suitable for use in public and non-public networks.

A connection to IT networks (networks without reference to earth potential) is permissible only to a limited extent, because the device's built-in filter capacitors connect the network with the earth potential (enclosure). On earth free networks, this can lead to dangerous situations or damage to the device (isolation monitoring required).

To the output of the frequency inverter (terminals U, V, W) you must not:

- connect a voltage or capacitive loads (for example, phase compensation capacitors)
- connect multiple frequency inverters in parallel
- make a direct connection to the input (bypass)

Observe the technical data and connection requirements. For additional information, refer to the equipment nameplate or label at the frequency inverter, and the documentation.

Any other usage constitutes improper use.



## Maintenance and inspection

PowerXL frequency inverters are maintenance free. However, external influences may affect the function and the lifespan of the PowerXL frequency inverter. We therefore recommend that the devices are checked regularly and the following maintenance measures are carried out at the specified intervals.

If the PowerXL frequency inverter is damaged by external influences, contact Technical Service.

**Table 26. Maintenance measures and intervals**

Maintenance measure	Maintenance interval
Clean cooling vents (cooling slits)	If required
Check the fan function	6–24 months (depending on the environment)
Filter in the switching cabinet doors (see manufacturer specifications)	6–24 months (depending on the environment)
Check the tightening torques of the terminals (control signal terminals, power terminals)	Regularly
Check connection terminals and all metallic surfaces for corrosion	6–24 months (depending on the environment)

## Storage

If the frequency inverter is stored before use, suitable ambient conditions must be ensured at the site of storage:

- Storage temperature: –40 °F to 158 °F (–40 °C to 70 °C)
- Relative average air humidity: <95%, noncondensing (EN 50178)
- To prevent damage to the DC link capacitors, storage times longer than 12 months are not recommended

## Charging the internal DC link capacitors

After extended storage times or extended downtimes during which no power is supplied (>12 months), the capacitors in the internal DC link must be recharged in a controlled manner in order to prevent damage. To do this, the PowerXL variable frequency drive must be supplied with power, with a controlled DC power supply unit, via two mains DC bus connection terminals. Please consult the factory for detailed instructions.

## Service and warranty

In the unlikely event that you have a problem with your PowerXL frequency inverter, please contact your local sales office.

When you call, have the following information ready:

- the exact frequency inverter part no. (see nameplate)
- the date of purchase
- a detailed description of the problem that has occurred with the frequency inverter

If some of the information printed on the nameplate is not legible, please state only the information that is clearly legible. This information can also be found on the cover of the control terminals.

Information concerning the guarantee can be found in the General Terms and Conditions of Sale.

## Chapter 4—Safety and switching

**Note:** All following information is strongly recommended but is not necessary if sufficient system design and validation has been completed.

### Fuses and cable cross-sections

The fuses and wire cross-sections allocated for power-side connections depend on the rated input current and output current of the frequency inverter (without AC choke).

---

**CAUTION**

---

When selecting the cable cross-section, take the voltage drop under load conditions into account.

The consideration of other standards (for example, VDE 0113 or VDE 0289) is the responsibility of the user.

The national and regional standards (for example VDE 0113, EN 60204) must be observed and the necessary approvals (for example UL) at the site of installation must be fulfilled.

When the device is operated in a UL-approved system, use only UL-approved fuses, fuse bases, and cables.

See **Appendix D**—Safety Instructions for UL and cUL for details.

---

**CAUTION**

---

The specified minimum PE conductor cross-sections in this manual must be maintained. The minimum size of the protective earthing conductor must comply with the requirements of EN 61800-5-1 and/or the local safety regulations.

Touch currents in this frequency inverter are greater than 3.5 mA (AC). According to product standard IEC/EN 61800-5-1, an additional equipment grounding conductor of the same cross-sectional area as the original protective earthing conductor must be connected, or the cross-section of the equipment grounding conductor must be at least 10 mm<sup>2</sup> Cu.

Choose the cross-section of the PE conductor in the motor lines at least as large as the cross-section of the phase lines (U, V, W).

### Cables and fuses

The cross-sections of the cables and line protection fuses used must correspond with local standards.

For an installation in accordance with UL guidelines:

- Use UL listed Class RK5, J, T or equivalent fuses for the branch circuit protection
- Use 75 °C or higher copper wire only
- Use UL listed conduit fittings with the same type rating (Type 1/Type 12) as the enclosure

See **Appendix D**—Safety Instructions for UL and cUL for details.

Use power cables with insulation according to the specified input voltages for the permanent installation. A shielded cable is not required on the input side.

A completely (360°) shielded low impedance cable is required on the motor side. The length of the motor cable depends on the RFI class and must not exceed approximately 300 ft (100 m) without additional filtering.

### Residual-current device (RCD)

RCD (Residual Current Device): Residual current device, residual current circuit breaker (FI circuit breaker).

Residual current circuit breakers protect persons and animals from the existence (not the origination) of impermissibly high contact voltages. They prevent dangerous, and in some cases deadly injuries caused by electrical accidents, and also serve as fire prevention.

---

**CAUTION**

---

This drive can cause a DC current in the protective earthing conductor. Where a residual current-operated protective (RCD) or monitoring (RCM) device is used for protection in case of direct or indirect contact, only an RCD or RCM of Type B is allowed on the supply side of this product.

**Figure 12. Identification on the FI circuit breakers**

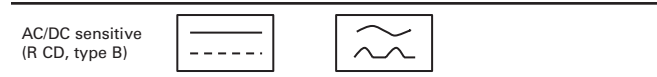

Frequency inverters work internally with rectified AC currents. If an error occurs, the DC currents can block a type A RCD circuit breaker from triggering and therefore disable the protective functionality.

---

** CAUTION**

---

Debounced inputs may not be used in the safety circuit diagram.

Residual current circuit breakers (RCD) are only to be installed between the AC power supply network and the frequency inverter.

Safety-relevant leakage currents can occur while handling and when operating the frequency inverter, if the frequency inverter is not grounded (because of a fault).

Leakage currents to ground are mainly caused by foreign capacities with frequency inverters, between the motor phases and the shielding of the motor cable and via the Y-capacitors of the RFI filter. The size of the leakage current is mainly dependent upon the:

- length of the motor cable
- shielding of the motor cable
- height of the switching frequency of the inverter
- design of the RFI filter
- grounding measures at the site of the motor

The leakage current to ground is greater than 3.5 mA with a frequency inverter. According to product standard IEC/EN 61800-5-1, an additional equipment grounding (PE) conductor of the same cross-sectional area as the original protective earthing conductor should be connected, or the cross-section of the equipment grounding conductor should be at least 10 mm<sup>2</sup> Cu.

Residual current circuit breakers must be suitable for:

- the protection of installations with DC current component in case of fault scenario (RCD type B)
- high leakage currents
- brief discharges of pulse current spikes

### Leakage current

---

** CAUTION**

---

As shown in **Table 16**, the following leakage currents were detected. These values were obtained under normal operating conditions with no outside influences. Actual values will differ depending on the conditions previously explained.

### Input contactor

The input contactor enables an operational switching on and off of the supply voltage for the frequency inverter, and switching off in case of a fault.

The input contactor is designed based on the input current (ILN) of the frequency inverter and the utilization category AC-1 (IEC 60947). Input contactors and the assignment to PowerXL frequency inverters are explained in **Appendix A**.

While planning the project, make sure that inching operation is not done via the input contactor of the frequency inverter on frequency-controlled drives, but through a controller input of the frequency inverter.

The maximum permitted operating frequency of the input voltage with the PowerXL frequency inverter is one time per minute (normal operation).

**EMC Measures**

Electrical components in a system (machine) have an interaction effect on each other. Each device not only emits interference but is also affected by it. The interference can be produced by galvanic, capacitive, and/or inductive sources, or by electromagnetic radiation. In practice, the limit between line-conducted interference and radiated emitted interference is around 30 MHz. Above 30 MHz, cables and conductors act like antennas that radiate electromagnetic waves.

Electromagnetic compatibility (EMC) for frequency controlled drives (variable frequency drives) is implemented in accordance with product standard IEC/EN 61800-3. This includes the complete power drive system (PDS), from the input supply to the motor, including all components, as well as cables. This type of drive system can consist of several individual drives.

The generic standards of the individual components in a PDS compliant with IEC/EN 61800-3 do not apply. These component manufacturers, however, must offer solutions that ensure standards-compliant use.

In Europe, maintaining the EMC guidelines is mandatory.

A declaration of conformity (CE) always refers to a “typical” power drive system (PDS). The responsibility to comply with the legally stipulated limit values and thus the provision of electromagnetic compatibility is ultimately the responsibility of the end user or system operator. This operator must also take measures to minimize or remove emission in the environment concerned (see **Figure 13**). He must also use means to increase the interference immunity of the devices of the system.

With their high interference immunity up to category C2, PowerXL frequency inverters are ideal for use in commercial networks (1st environment).

**Table 27. Motor power cable EMC guidelines**

Item	Directive
Product	IEC 61800-2
Safety	UL 508C, IEC/EN 61800-5-1
EMC (at default settings)	Immunity (EMS): IEC/EN 61800-3, 2nd environment
	Radiated and Conducted emissions (EMI): IEC/EN 61800-3
230/480 V Series:	
Category C1: is possible with external filter connected to drive. Please consult factory	
Category C2: with internal filter maximum of 10 m motor cable length	
FR0: This is obtained with 2 turns on a ferrite core and using metal ground plate	
Category C3: with internal filter maximum of 50 m motor cable length	
FR0: This is obtained with no ferrite core and metal plate	
575 V Series:	
Category C3: with internal filter maximum of 10 m motor cable length	

**Figure 13. EMC Measures**

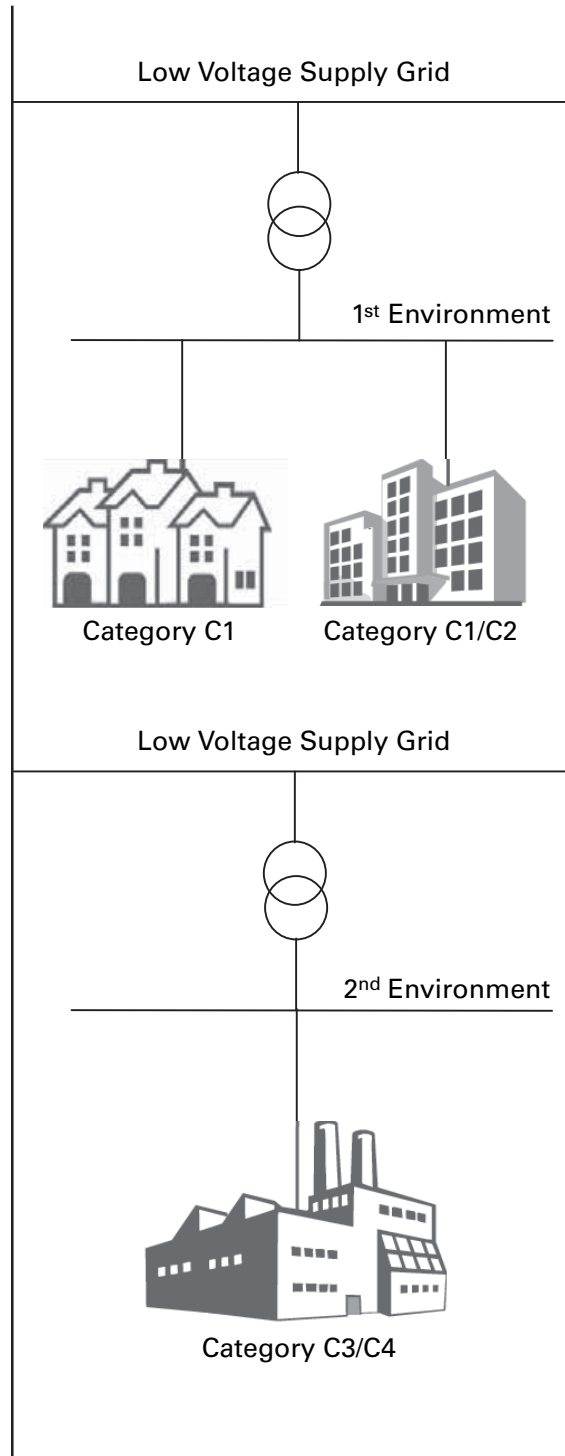

## Chapter 5—Motor and application

**Note:** All following information is strongly recommended but is not necessary if sufficient system design and validation has been completed.

### Motor selection

General recommendations for motor selection:

- Use three-phase powered asynchronous motors with short-circuit rotors and surface cooling, also called inverter motors or standard motors for the frequency-controlled drive system (PDS). Other specifications such as external rotor motors, slip-ring motors, reluctance motors, synchronous or servo motors can also be run with a frequency inverter, but normally require additional planning and discussion with the motor manufacturer
- Use only motors with at least heat class F (311 °F [155 °C] maximum steady state temperature)
- Four-pole motors are preferred (synchronous speed: 1500 min<sup>-1</sup> at 50 Hz or 1800 min<sup>-1</sup> at 60 Hz)
- Take the operating conditions into account for S1 operation (IEC 60034-1)
- When operating multiple motors in parallel on one frequency inverter, the motor output should not be more than three power classes apart
- Ensure that the motor is not over-dimensioned. If a motor in speed control mode is under-dimensioned, the motor rating must only be one rating level lower

### Connecting motors in parallel

The PowerXL frequency inverters allow parallel operation of several motors using multi-pump application control mode:

- *Multi-pump application: several motors with the same or different rated operational data.* The sum of all motor currents must be less than the frequency inverter's rated operational current
- *Multi-pump application: parallel control of several motors.* The sum of the motor currents plus the motors' inrush currents must be less than the frequency inverter's rated operational current

Parallel operation at different motor speeds can be implemented only by changing the number of pole pairs and/or changing the motor's transmission ratio.

---

### CAUTION

---

Debounced inputs may not be used in the safety circuit diagram.

If you are connecting multiple motors on one frequency inverter, you must design the contactors for the individual motors according to utilization category AC-3.

Selecting the motor contactor is done according to the rated operational current of the motor to be connected.

## Parallel connection of several motors to one frequency inverter

Figure 14. Parallel connection

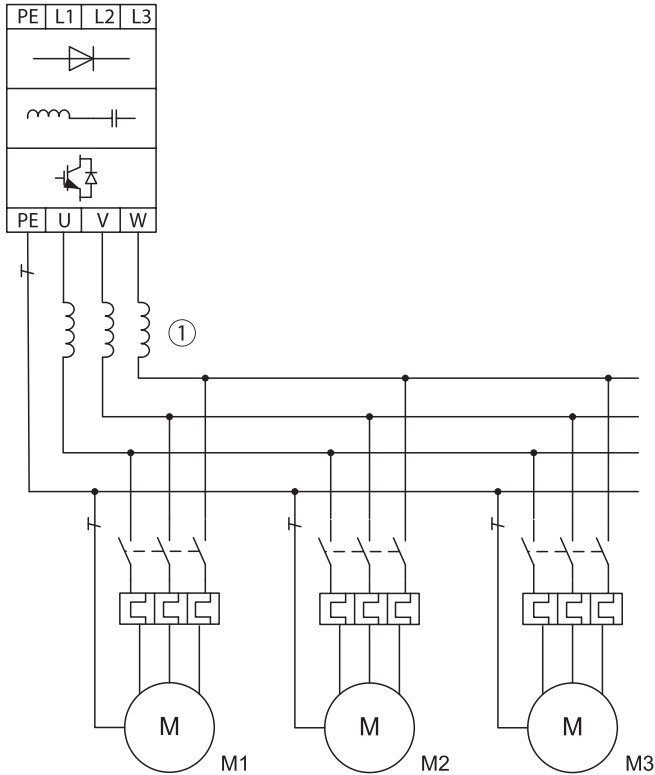

Connecting motors in parallel reduces the load resistance at the frequency inverter output. The total stator inductance is lower and the leakage capacity of the lines greater. As a result, the current distortion is greater than in a single-motor circuit. To reduce the current distortion, you should use motor reactors (see ① in **Figure 14**) in the output of the frequency inverter.

The current consumption of all motors connected in parallel must not exceed the frequency inverter's rated output current  $I_{2N}$ .

Electronic motor protection cannot be used when operating the frequency inverter with several parallel connected motors. You must, however, protect each motor with thermistors and/or overload relays.

The use of a motor protective circuit breaker at the frequency inverter's output can lead to nuisance tripping.

## Motor and circuit type

The motor's stator winding can be connected in a star or delta configuration, in accordance with the rated operational data on the nameplate.

Figure 15. Example of a motor ratings plate

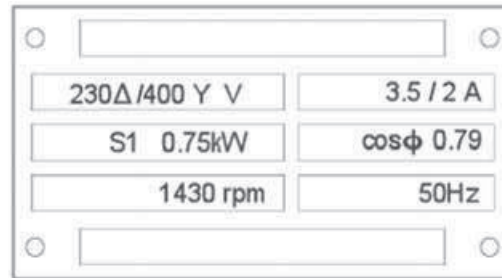
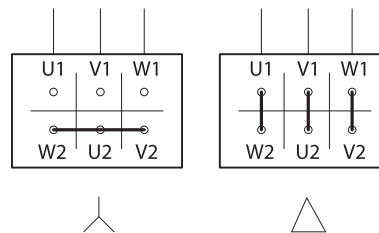

Figure 16. Star and delta circuit types



The three-phase motor with the rating plate based on **Figure 15**, can be run in a star or delta connection. The operational characteristic curve is determined by the ratio of motor voltage and motor frequency, in this case.

### 87 Hz characteristic curve

In the delta circuit with 400 V and 87 Hz, the motor shown in **Figure 15** was released with three times-fold output (~1.3 kW).

Because of the higher thermal loading, using only the next higher motor output according to the list (1.1 kW) is recommended. The motor (in this example) therefore still has 1.47-fold higher output compared with the listed output (0.75 kW).

With the 87 Hz characteristic curve, the motor also works in the range from 50 Hz to 87 Hz with an un-attenuated field. The pull-out torque remains at the same level as in input operation with 50 Hz.

The heat class of the motor must be at least F in 87 Hz operation.

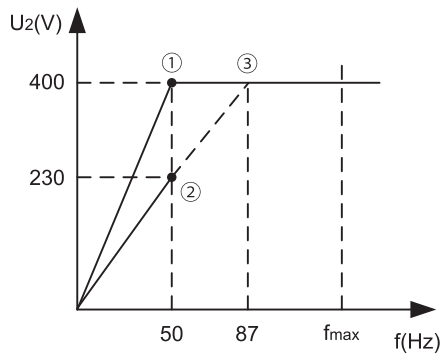
**V/Hz characteristic curve****Figure 17. V/Hz characteristic curve**

**Table 28** shows the allocation of possible frequency inverters depending on the input voltage and the type of circuit.

**Table 28. Assignment of frequency inverters to example motor circuit (see Figure 17)**

Frequency inverters	D_1-323D7FB	D_1-343D3FB	D_1-344D3FB
Rated operational current	3.7 A	3.3 A	4.3 A
Input voltage	3 AC, 230 V	3 AC, 400 V	3 AC, 400 V
Motor circuit	Delta	Star	Delta
V/Hz characteristic curve	②	①	③
Motor current	3.5 A	2.0 A	3.5 A
Motor voltage (ratings plate)	230 V	400 V	230 V
Motor speed	1430 min <sup>-1</sup>	1430 min <sup>-1</sup>	2474 min <sup>-1</sup> ④
Motor frequency	50 Hz	50 Hz	87 Hz ③

**Notes:** ① Star connection: 400 V, 50 Hz.  
 ② Delta connection: 230 V, 50 Hz.  
 ③ Delta connection: 400 V, 87 Hz.  
 ④ Note the permitted limit values of the motor.

### Bypass operation

If you want to have the option of operating the motor with the frequency inverter or directly from the input supply, the input branches must be interlocked mechanically.

#### CAUTION

Debounced inputs may not be used in the safety circuit diagram.

A changeover between the frequency inverter and the input supply must take place in a voltage-free state.

#### WARNING

**The frequency inverter outputs (U, V, W) must not be connected to the input voltage (destruction of the device, risk of fire).**

Figure 18. Bypass motor control (example)

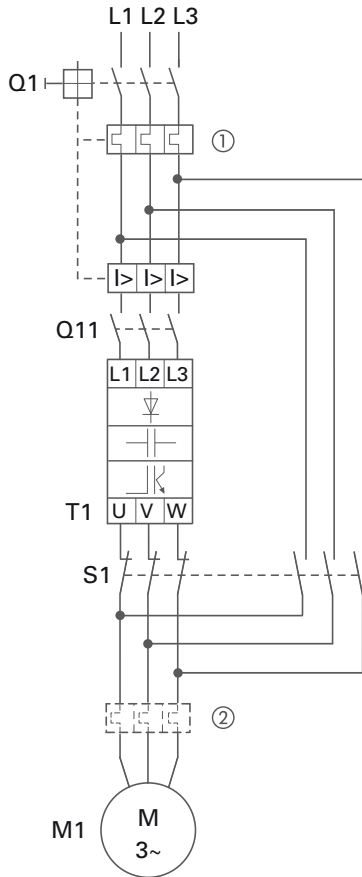

Table 29. Bypass motor control

Item No.	Description
1	Input/bypass contactor
2	Output contactor

#### CAUTION

Debounced inputs may not be used in the safety circuit diagram.

Switch S1 must switch only when frequency inverter T1 is at zero current.

Contactors and switches (S1) in the frequency inverter output and for the direct start must be designed based on utilization category AC-3 for the rated operational current of the motor.

### Connecting EX motors

Note the following when connecting explosion-protected motors:

- The frequency inverter must be installed outside the EX area
- Note the branch- and country-specific standards for explosion-protected areas (ATEX 100 A)
- Note the standards and information of the motor manufacturer regarding operation on frequency inverters—for example, if motor reactors or sine-wave filters are specified
- Temperature monitors in the motor windings (thermistor, thermo-Click) are not to be connected directly to frequency inverters but must be connected via an approved trigger apparatus for EX areas



## Chapter 6—Installation requirements

**Note:** All following information is strongly recommended but is not necessary if sufficient system design and validation has been completed.

This chapter contains all of the information required to properly install and prepare the PowerXL Series VFD for operation. The contents are listed to serve as a list of tasks needed to complete the installation. Included in this section are:

- Line (mains) and motor power wiring
- I/O control wiring

### Electrical installation warnings and cautions

---

#### WARNING

**Carry out wiring work only after the frequency inverter has been correctly mounted and secured.**

---

#### WARNING

**Electric shock hazard—risk of injuries!**

**Carry out wiring work only if the unit is de-energized.**

---

#### CAUTION

Debounced inputs may not be used in the safety circuit diagram.

Fire hazard!

Only use cables, protective switches, and contactors that feature the indicated permissible nominal current value.

---

#### CAUTION

Debounced inputs may not be used in the safety circuit diagram.

According to product standard IEC/EN 61800-5-1, an additional equipment grounding (PE) conductor of the same cross-sectional area as the original protective earthing conductor must be connected, or the cross-section of the equipment grounding conductor must be at least 10 mm<sup>2</sup> Cu.

---

#### WARNING

**The components in the drive's power section remain energized after the supply voltage has been switched off. After disconnecting the supply, wait at least five minutes before removing the cover to allow the intermediate circuit capacitors to discharge.**

**Pay attention to hazard warnings!**

### Standard mounting instructions

- Select the mounting location based on requirements listed in this chapter
- Mounting surface must be a vertical, flat, non-flammable surface
- PowerXL Series open drives may be mounted side-by-side or stacked vertically, as outlined in this chapter
- Surface must be strong enough to support the drive and not subject to excessive motion or vibration
- Mark the location of the mounting holes on the mounting surface (using the template provided on the cover of the cardboard shipping package)
- Using fasteners appropriate to your VFD and mounting surface, securely attach the VFD to the mounting surface using all four mounting hole locations

When mounting one unit above the other, the lower unit air outlet must be directed away from the inlet air used by the upper one. The clearance between the upper and lower unit should equal C + D. See **Figure 19** on next page.

1. Measure the mounting space to ensure that it allows the minimum space surrounding the VFD Series drive. Drive dimensions are on **Appendix C**
2. Make sure the mounting surface is flat and strong enough to support the drive, is not flammable, and is not subject to excessive motion or vibration
3. Ensure that the minimum airflow requirements for your drive are met at the mounting location
4. Mark the location of the mounting holes on the mounting surface, using the template provided on the cover of the cardboard shipping package
5. Using fasteners appropriate to your drive and mounting surface, securely attached the drive to the mounting surface using all four screws or bolts

### Mounting dimensions

Refer to **Appendix C** for drive dimensions.

Figure 19. Mounting space

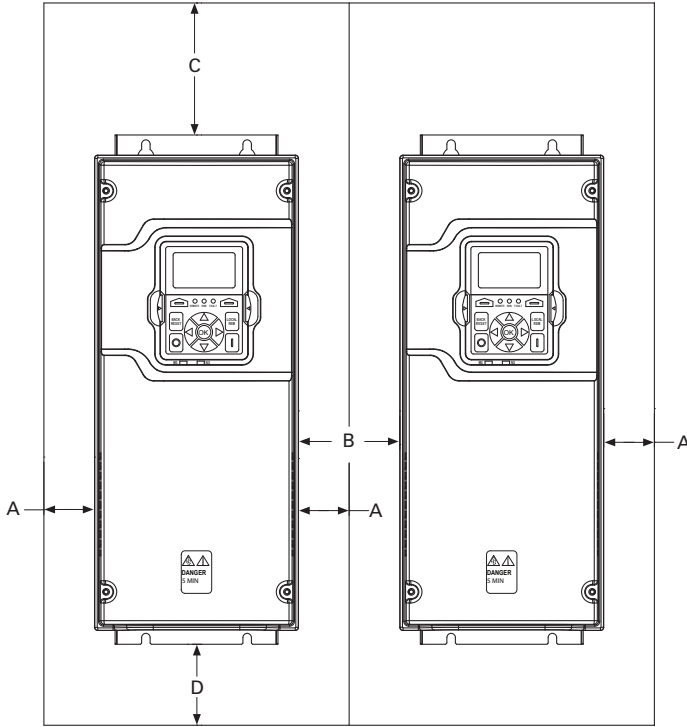

Table 30. Space requirements for mounting the PowerXL Series VFD and airflow

Frame size	A <sup>①</sup> In (mm)	B <sup>①</sup> In (mm)	C In (mm)	D In (mm)	Cooling air required CFM (m <sup>3</sup> /h) <sup>②</sup>
FR0	0	0	3.94 (100)	1.97 (50)	16.5 (28)
FR1 (IP21)	0.79 (20)	1.58 (40)	3.94 (100)	1.97 (50)	14 (24)
FR1 (IP54)	0	0	3.94 (100)	1.97 (50)	14 (24)
FR2 (IP21)	1.18 (30)	2.36 (60)	6.30 (160)	2.36 (60)	55 (94)
FR2 (IP54)	0	0	6.30 (160)	2.36 (60)	55 (94)
FR3	0	0	7.87 (200)	3.15 (80)	85 (144)
FR4	0	0	11.81 (300)	3.94 (100)	153 (260)
FR5	3.15 (80)	6.30 (160)	11.81 (300)	7.87 (200)	232 (395)
FR6	0	0	15.75 (400)	12.99 (330)	230 V: 435 (739) 480 and 575 V: 400 (679)

**Notes:** <sup>①</sup> The above guidelines apply unless testing has been completed to validate a design outside of these recommendations.

<sup>②</sup> Minimum clearances A and B for drives with Type 12 (IP54) enclosure is 0 mm (in).

## Dimensions

Approximate dimensions in mm

**Figure 20. Open Drives FR0–FR6**

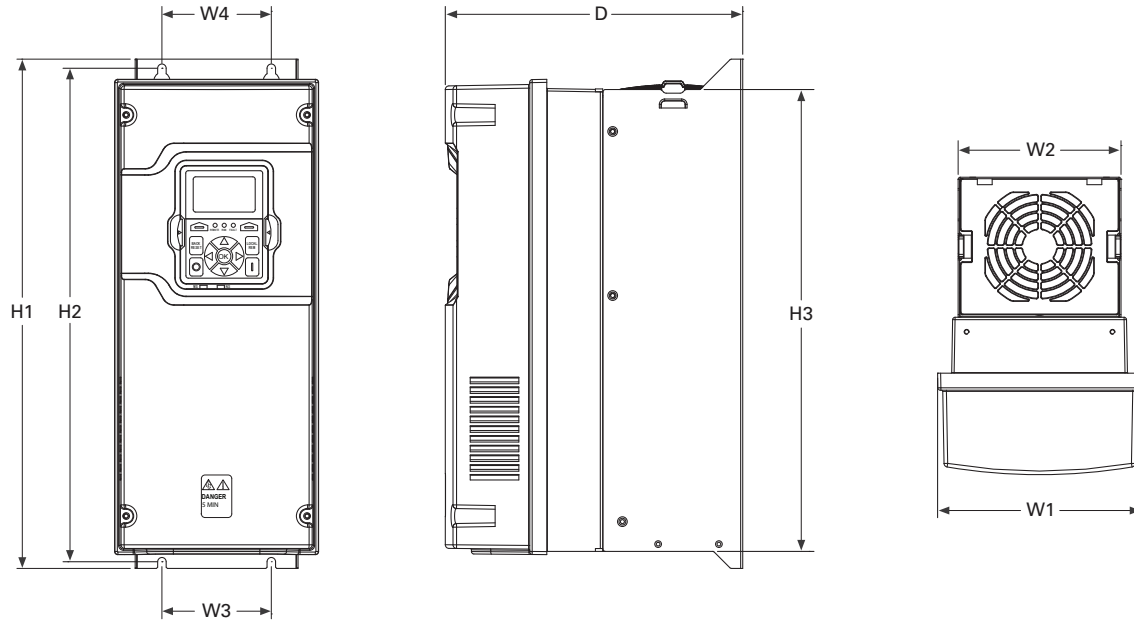

**Table 31. Mounting drive dimensions**

Frame size	Approximate dimensions in inches (mm)									Weight Lb (kg)
	D	H1	H2	H3	W1	W2	W3	W4	Ø	
FR0	6.83 (173.5)	10.58 (268.7)	10.16 (258.0)	9.54 (242.3)	5.00 (127.0)	4.97 (126.3)	4.26 (108.3)	4.26 (108.3)	0.28 (7.0)	4.41 (2.0)
FR1	7.91 (200.9)	12.87 (327.0)	12.28 (312.0)	11.50 (292.0)	6.02 (153.0)	4.80 (122.0)	3.94 (100.0)	3.94 (100.0)	0.28 (7.0)	14.33 (6.5)
FR2	9.63 (244.7)	16.50 (419.0)	15.98 (406.0)	14.96 (380.0)	6.61 (167.8)	5.28 (134.0)	3.54 (90.0)	3.54 (90.0)	0.28 (7.0)	23.37 (10.6)
FR3	10.44 (265.1)	21.97 (558.0)	21.46 (545.0)	20.41 (518.5)	8.06 (204.6)	7.24 (184.0)	4.92 (125.0)	4.92 (125.0)	0.35 (9.0)	49.82 (22.6)
FR4	11.57 (294.0)	24.80 (630.0)	24.31 (617.5)	23.26 (590.7)	9.36 (237.7)	9.13 (232.0)	8.07 (205.0)	8.07 (205.0)	0.35 (9.0)	77.60 (35.2)
FR5	13.41 (340.7)	34.98 (888.5)	29.65 (753.0)	27.83 (707.0)	11.34 (288.0)	11.10 (282.0)	8.66 (220.0)	8.66 (220.0)	0.35 (9.0)	154.32 (70.0)
FR6	14.61 (371)	40.75 (1035)	33.27 (845)	31.38 (797)	19.13 (486)	18.90 (480)	15.75 (400)	15.75 (400)	0.35 (9)	246.91 (112)

## Standard drive mounting

### FR0 mounting instructions

**Step 1:** Lift the drive out from the carton, remove the packaging.

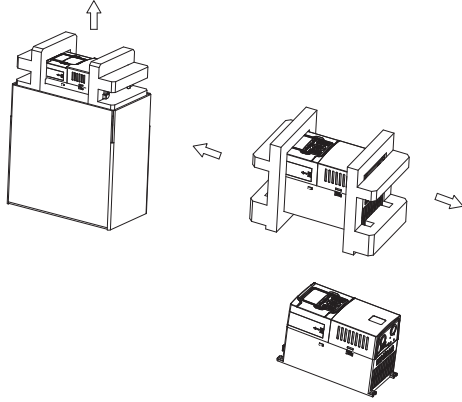

**Step 2:** Attach the drive to the mounting plate with four M5x15 screws and four M5 nuts. The opening dimension on the mounting plate should follow required dimension (refer to the drive mounting template printed on the outside carton). The drive can be mounted vertically or horizontally according to customer's needs.

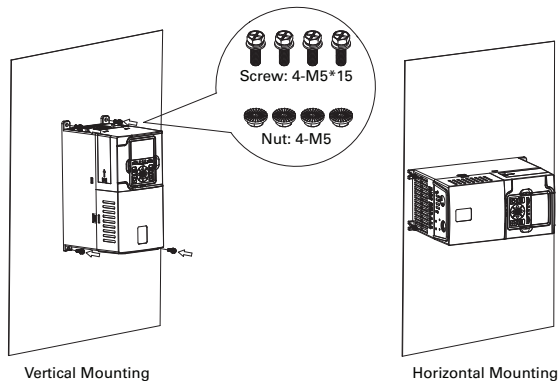

### Step 3:

1. EN version FR0 or U.S. version FR0 with EMC kit.
  - a. **Input wiring:** Run the L1, L2, L3 wires through a magnetic ring and wind one lap, fix the L1, L2, L3 wires and magnetic ring with a cable tie, then connect the L1, L2, L3 wires to input terminals. Connect the input grounding wire to the bottom metal plate with an M4x10 screw.
  - b. **Output wiring:** Attach an L-shape EMC grounding plate to the bottom of drive with two M4x8 flat screws. Connect the output U, V, W wires to output terminals. Connect the output grounding wire to the bottom metal plate with an M4x10 screw. Clamp the output cable shield to the L-shape EMC grounding plate with a small rectangular EMC grounding plate and two M4x15 screws.
2. U.S. version FR0 without EMC kit, there are no magnetic ring and EMC grounding plates, but it is necessary to connect the output cable shield to the bottom metal surface with an M4x10 screw.

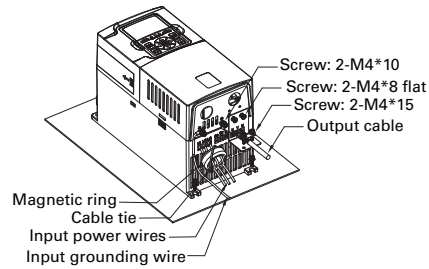

**FR1 mounting instructions**

**Step 1:** Lift the drive out from the carton. Remove the packaging.

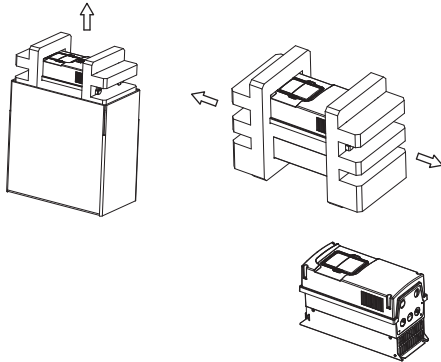

**Step 2:** Attach the drive to the mounting plate with four M5x15 or 3/16 inch screws and four M5 or 3/16 inch nuts. The opening dimensions on the mounting plate should follow required dimensions (refer to the drive mounting template printed on the outside carton).

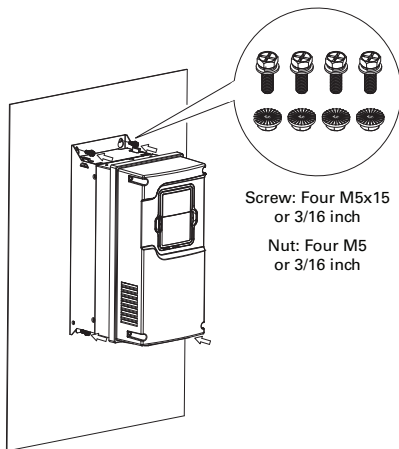

**FR2 mounting instructions**

**Step 1:** Lift the drive out from the carton. Remove the packaging.

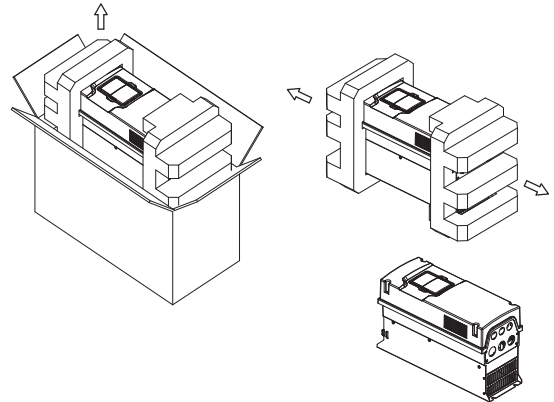

**Step 2:** Attach the drive to the mounting plate with four M5x15 or 3/16 inch screws and four M5 or 3/16 inch nuts. The opening dimensions on the mounting plate should follow required dimensions (refer to the drive mounting template printed on the outside carton).

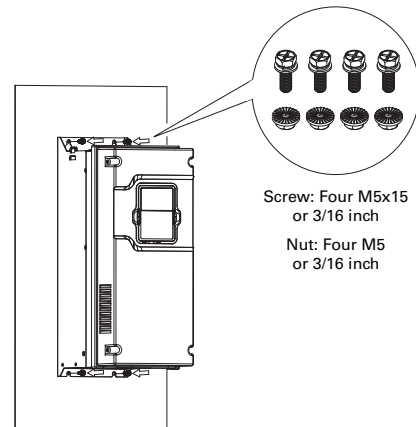

**FR3 mounting instructions**

**Step 1:** Lift the drive out of the carton. Remove the packaging.

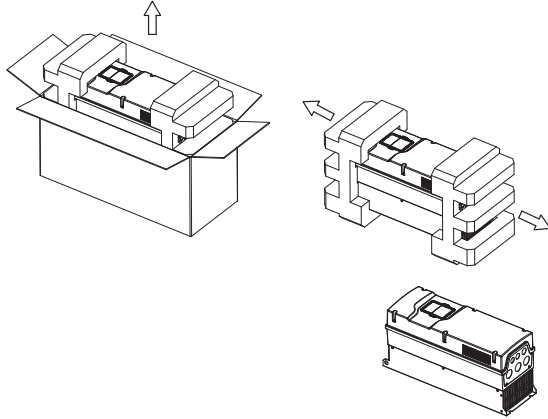

**Step 2:** Attach the drive to the mounting plate with four M6x15 or 1/4 inch screws and four M6 or 1/4 inch nuts. The opening dimensions on the mounting plate should follow required dimensions (refer to the drive mounting template printed on the outside carton).

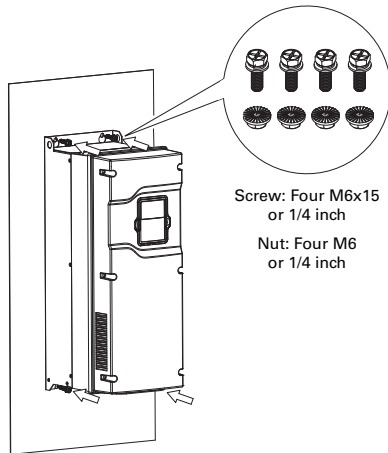

**FR4 mounting instructions**

**Step 1:** Lift the drive out of the carton with the cardboard. Remove the packaging.

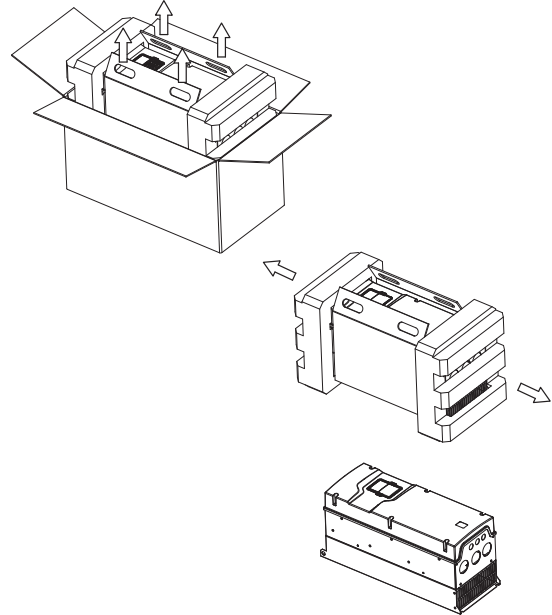

**Step 2:** Attach the drive to the mounting plate with four M8x15 or 3/8 inch screws and four M8 or 3/8 inch nuts. The opening dimensions on the mounting plate should follow required dimensions (refer to the drive mounting template printed on the outside carton).

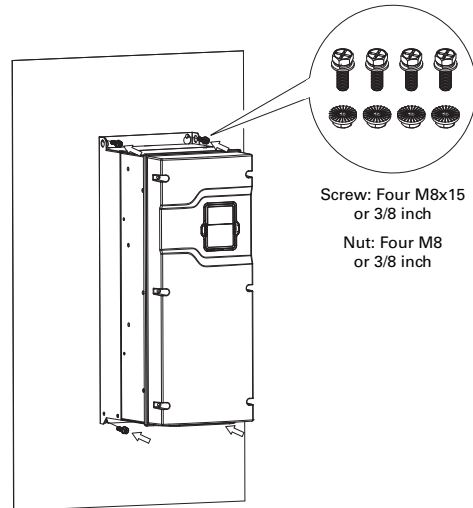

**FR5 mounting instructions**

**Step 1:** Remove the carton from the drive.

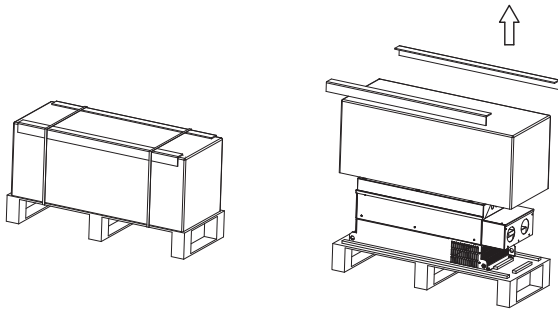

**Step 2:** Remove the four screws (used to fix the drive to the pallet) with an M8 or 3/8 inch wrench.

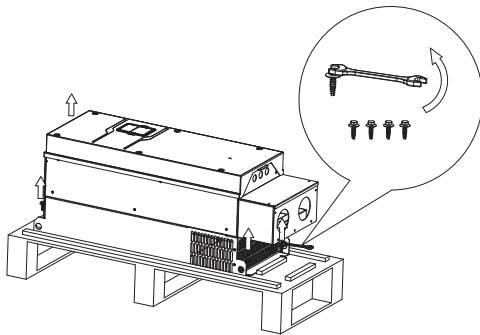

**Step 3:** Use a hook to lift the drive.

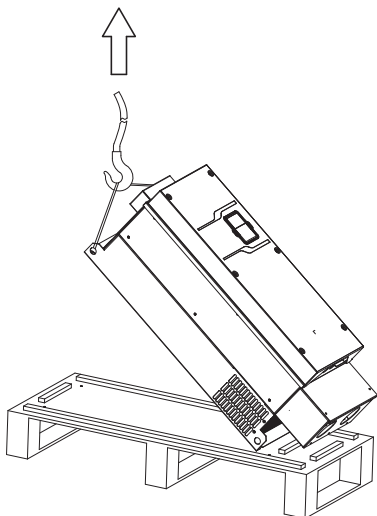

**Step 4:** Attach the drive to the mounting plate with four M8x20 or 3/8 inch screws and four M8 or 3/8 inch nuts with an M8 or 3/8 inch wrench. The opening dimensions on the mounting plate should follow required dimensions (refer to the drive mounting template printed on the outside carton).

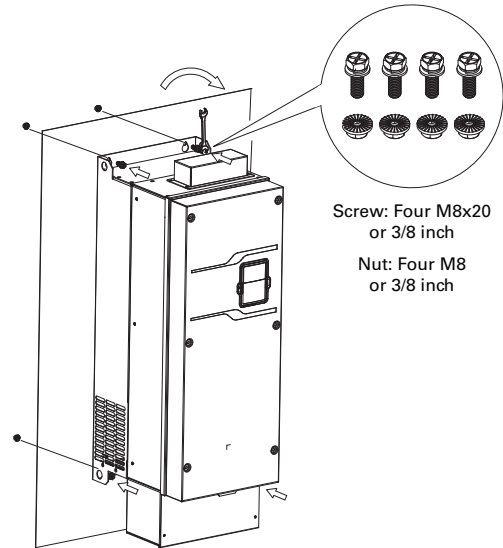

## Chapter 6—Installation requirements

### FR6 mounting instructions

**Step 1:** Remove the carton from the drive.

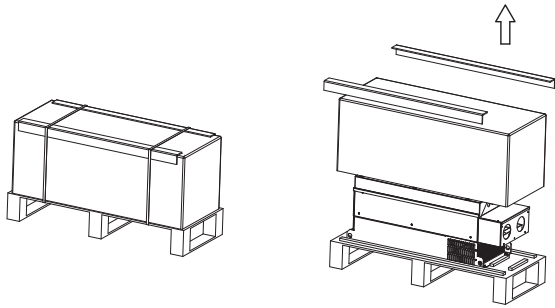

**Step 2:** Remove the four screws (used to fix the drive to the pallet) with an M8 or 3/8 inch wrench.

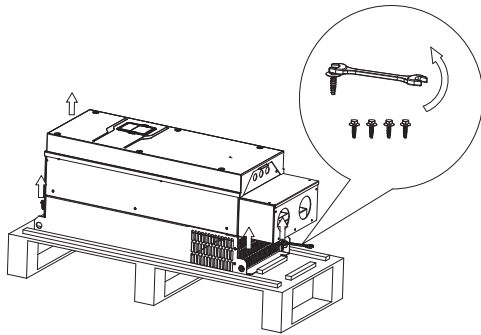

**Step 3:** Use a hook to lift the drive.

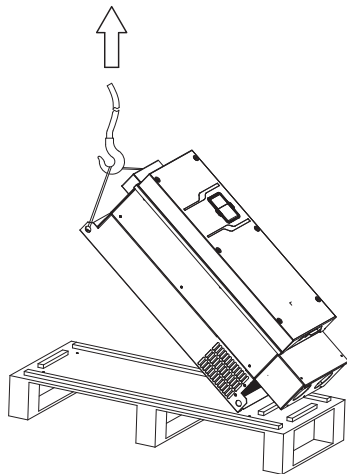

**Step 4:** Attach the drive to the mounting plate with four M8x20 or 3/8 inch screws and four M8 or 3/8 inch nuts with an M8 or 3/8 inch wrench. The opening dimensions on the mounting plate should follow the required dimensions (refer to the drive mounting template printed on the outside carton).

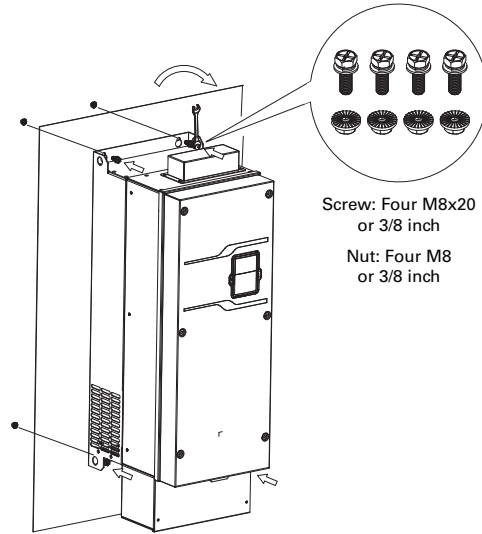

**Note:** The TLK series lug from KST for connecting is recommended, but other types can be used. The rated lug hole should be 1/2 inch or 13 mm to support the FR6 stud.



## FR6 wiring

Figure 21. FR6 wiring layout

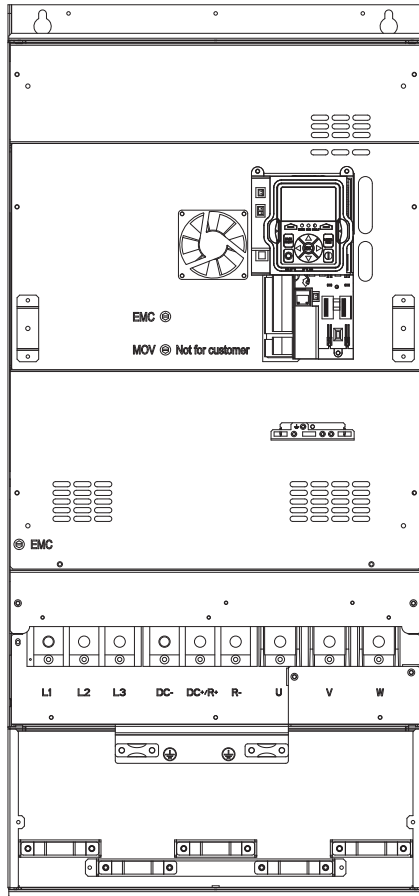

### FR6 wiring process

**Step 1:** Strip power wire jacket (Stripping length according to Table 36).

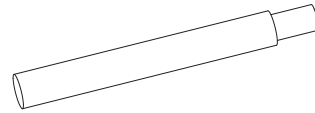

**Step 2:** Connect the power wire to a lug. Use a tool to press the wire and lug together tightly.

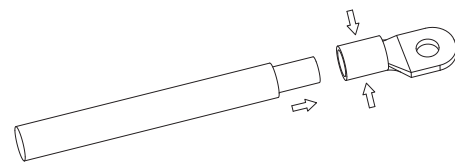

**Step 3:** Connect the power wire to the FR6 terminal block, lock the wire by a nut. Depending on the current level, one or two power wires can be connected to each pole of the terminal block.

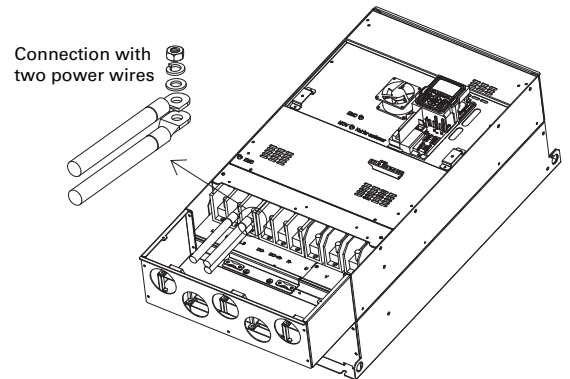

### Power wiring selection

Motor cable connections are made to terminals U, V, and W.

### Cable selection: Power and motor leads

- Use UL approved heat-resistant copper cables only
- 75 °C or higher for all units rated
- Line voltage/mains should be Class 1 wire only outside North America
- Refer to the following tables for cable sizing guidelines
  - North America 208 V to 240 V: **Appendix B**
  - North America 380 V to 500 V: **Appendix B**
  - All other International 380 V to 600 V: **Appendix B**

### Line (Mains) and motor cable installation

The input line and motor cables must be sized in accordance with the rated PowerXL VFD input and output current.

If motor temperature sensing is used for overload protection, the output cable size may be selected based on the motor specifications.

Maximum symmetrical supply current is 100,000 A RMS for all size PowerXL VFDs.

### Input protection

Input protection devices are rated based on PowerXL rated input and output current. For UL and cUL/CSA, refer to **Appendix D** for proper sizing. For gG/gL (IEC 60269-1), refer to **Appendix B** for proper sizing.

Consult with service representative for further information about input protection requirements.

### Brake chopper connection

Dynamic braking resistor connections are made to the R+ and R- terminal on the drive. Wire size should be followed according to the wattage being transferred. Below are images of the locations for wiring.

**Figure 22. Brake resistor wiring**

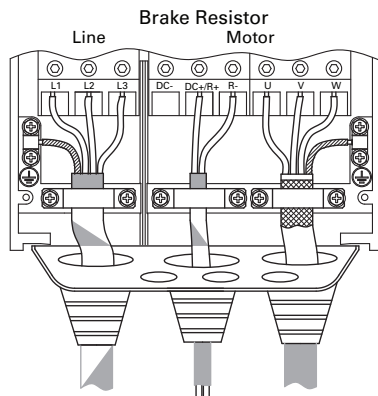

Note: This is a representation, depending on frame size, the image could change.

### FR5 design

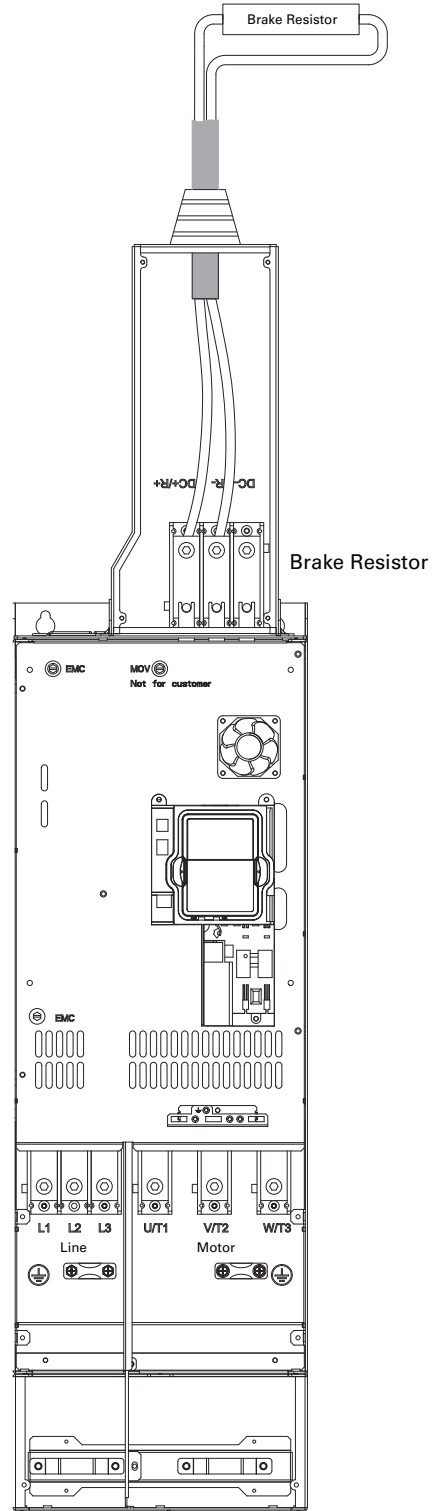

### Connection tightening torque

**Table 32. Tightening torque** ①②

Frame Size	Power wire In-Lb (Nm)	Ground wire In-Lb (Nm)	Control wire ③ In-Lb (Nm)
FR0	5.3 (0.6)	14 (1.6)	4.5 (0.5)
FR1	5.3 (0.6)	10 (1.1)	4.5 (0.5)
FR2	15.6 (1.8)	10 (1.1)	4.5 (0.5)
FR3	40 (4.5)	10 (1.1)	4.5 (0.5)
FR4	95 (10.7)	14 (1.6)	4.5 (0.5)
FR5	354 (40)	35 (4.0)	4.5 (0.5)
FR6	480 (54.2)	35 (4.0)	4.5 (0.5)

**Notes:** ① Strip the motor and power cables as shown in **Figure 23**.

② Both UL and IEC tools may be used.

③ Applies to strained wire, solid wire, or ferrule installations.

**Table 33. Spacing between parallel motor cables**

Cable length	Distance between cables
Less than 164 ft (50 m)	1 ft (0.3 m)
Less than 657 ft (200 m)	3 ft (1.0 m)

**Figure 23. Input power and motor cable stripping lengths**

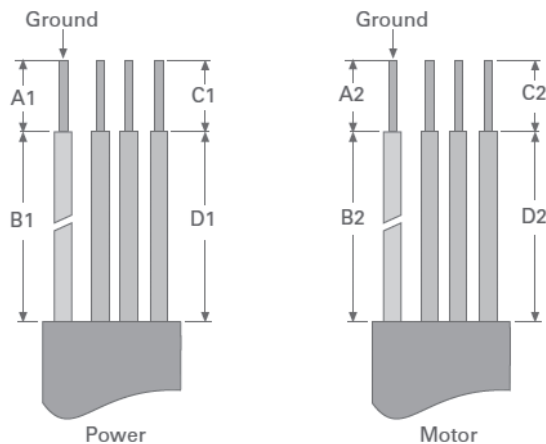

**Table 36. Input power and motor cable stripping and wire lengths**

Frame Size	Power wiring in inches (mm)				Motor wiring in inches (mm)			
	A1	B1	C1	D1	A2	B2	C2	D2
FR0	0.39 (10)	5.12 (130)	0.39 (10)	5.12 (130)	0.39 (10)	3.15 (80)	0.39 (10)	1.97 (50)
FR1	0.39 (10)	1.77 (45)	0.39 (10)	1.38 (35)	0.39 (10)	1.77 (45)	0.39 (10)	1.38 (35)
FR2	0.59 (15)	1.77 (45)	0.59 (15)	1.77 (45)	0.59 (15)	1.57 (40)	0.59 (15)	1.57 (40)
FR3	0.59 (15)	1.57 (40)	0.59 (15)	1.97 (50)	0.59 (15)	1.57 (40)	0.59 (15)	1.97 (50)
FR4	0.98 (25)	2.56 (65)	0.98 (25)	4.72 (120)	0.98 (25)	2.56 (65)	0.98 (25)	4.72 (120)
FR5	1.10 (28)	6.10 (155)	1.10 (28)	9.45 (240)	1.10 (28)	6.10 (155)	1.10 (28)	9.45 (240)
FR6	0.98 (25)	4.72 (120)	0.98 (25)	7.87 (200)	0.98 (25)	4.72 (120)	0.98 (25)	7.87 (200)

**Table 34. Maximum motor power cable length 230/480 V** ①

Frame size	Maximum cable length
FR0	100 m (328 ft)
FR1	100 m (328 ft)
FR2	150 m (492 ft)
FR3	150 m (492 ft)
FR4	200 m (656 ft)
FR5	200 m (656 ft)
FR6	200 m (656 ft)

**Note:** ① Lengths above are without EMC considerations.

**Table 35. Maximum motor power cable lengths 575 V**

Frame size	Maximum cable length
FR1	
FR2	
FR3	
FR4	
FR5	
FR6	12.2 m (40 ft)

**Note:** To achieve the maximum cable length, VFD shielded cable is required on motor side with proper grounding and cable layout.

## Chapter 6—Installation requirements

### Cable routing

If conduit is being used for wiring, use separate conduits for line voltage (mains), motor cables, and all interface/control wiring.

To meet the UL requirements, if conduit is being used for wiring, the enclosure openings provided for conduit connections in the field shall be closed by UL listed conduit fittings with the same type rating (Type 1 / Type 12) as the enclosure.

Avoid running motor cables alongside or parallel to any other wiring. If it is necessary to run motor cables with other wiring, then maintain spacing between motor cables and other wiring in accordance with **Table 33**.

### Wiring the VFD

Refer to **Table 34** and **Table 35** for maximum cable lengths by frame size.

If three or more motor cables are used, each conductor must have its own overcurrent protection.

### Power wiring notice

Do not discard the plastic bag containing the wiring hardware.

1. Remove the A-cover by removing (4) screws, then lifting the A-cover away from the base



### Wiring hardware contents (included with drive)

- European rubber grommet and flat rubber grommet (for IP54 integrity)
- Modification label
- Detachable cable clamp
- Attachable grounding strap
- Ground strap mounting screws

### Power wiring/grounding

2. Remove power wiring protection plate. Use power/motor cable tables on **Appendix B**
3. Add attachable grounding clamps (qty 2), one on each side of drive
4. Pass motor, input power wires/cables through base wiring plate
5. If shielded cable is used, connect the shields of input power and motor cables shields to ground

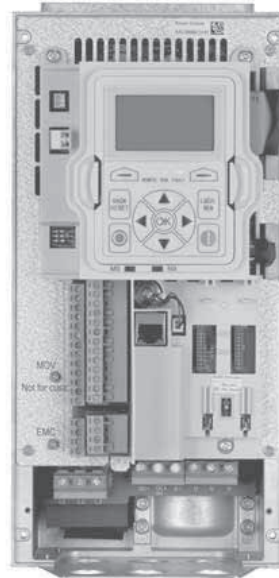

6. Wire power terminals (L1, L2, L3), motor terminal (U, V, W), and grounding terminals per **Figure 24**. It is recommended for power and motor leads to be in separate conduit

To meet the UL requirements, if conduit is being used for wiring, the enclosure openings provided for conduit connections in the field shall be closed by UL listed conduit fittings with the same type rating (Type 1/ Type 12) as the enclosure.

### Rubber grommet installation instructions

**Step 1:** Measure the outside diameter of the cable (D1) used to connect to the drive.

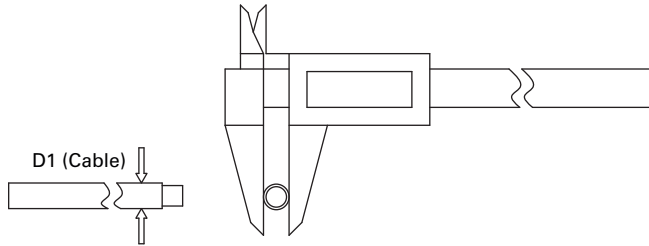

**Step 2:** Measure the outside diameter of the rubber grommet (D2) and select a suitable D2 ( $D1 \leq D2 \leq D1 + 2 \text{ mm}$ ).

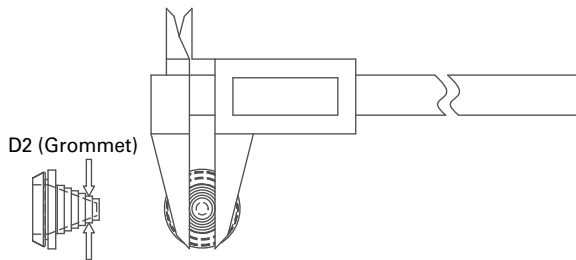

**Step 3:** Cut the rubber grommet at the selected diameter.

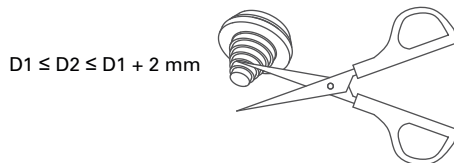

**Step 4:** Run the cable through the rubber grommet.

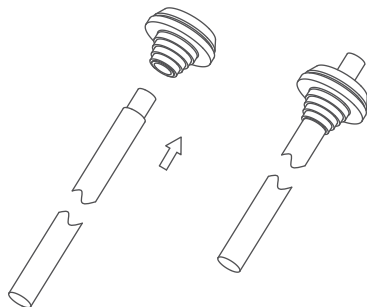

**Step 5:** Insert the rubber grommet into the conduit plate together with the cable.

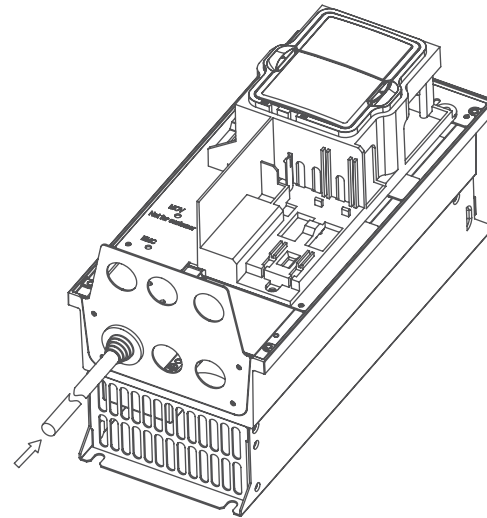

**Step 6:** Fasten the rubber grommet and cable with a self-locking cable tie.

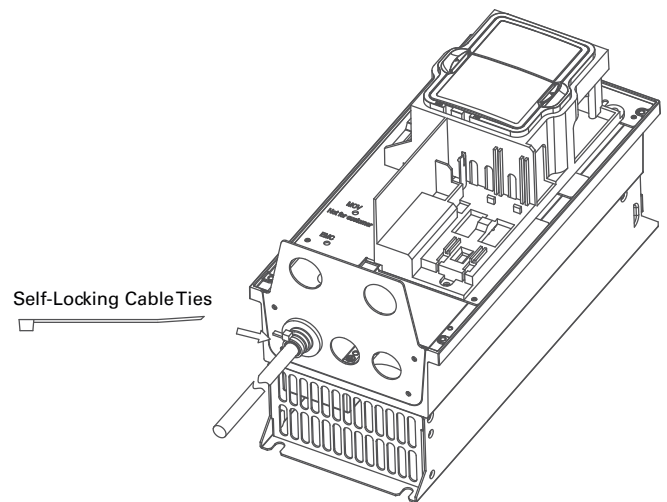

**Figure 24. Ground wiring**

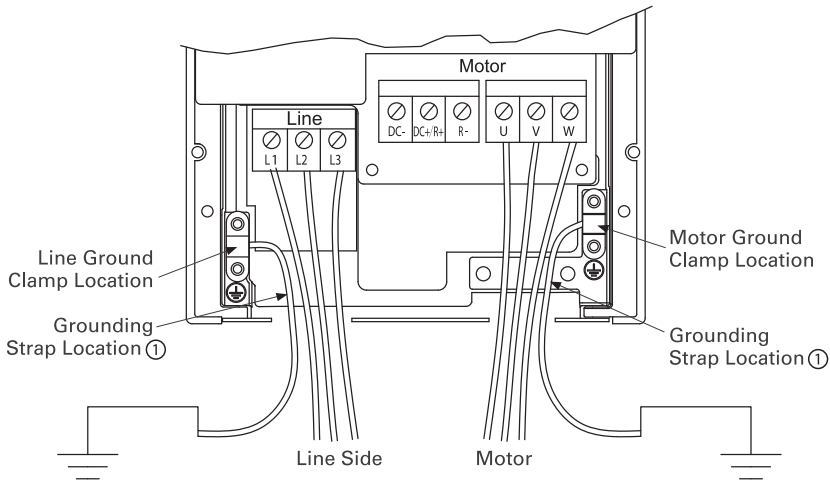

**Note:** Do not wire motor leads to R+, R-. This will cause damage to the drive.

**Note:** ① Actual layout may vary slightly by frame.

**Ground wiring**

- Run motor cables in separate conduit
- DO NOT RUN CONTROL WIRES in same conduit
- Cables sized per **Appendix B**
- Provide **dedicated** wire for low impedance ground between drive and motor. DO NOT USE conduit as ground

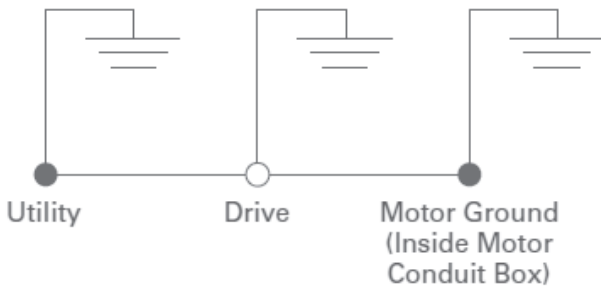

**CAUTION**

Improper grounding could result in damage to the motor and/or drive and could void warranty.

**Control wiring**

7. Wire the control terminals following the details for the specific option boards shown on the following pages

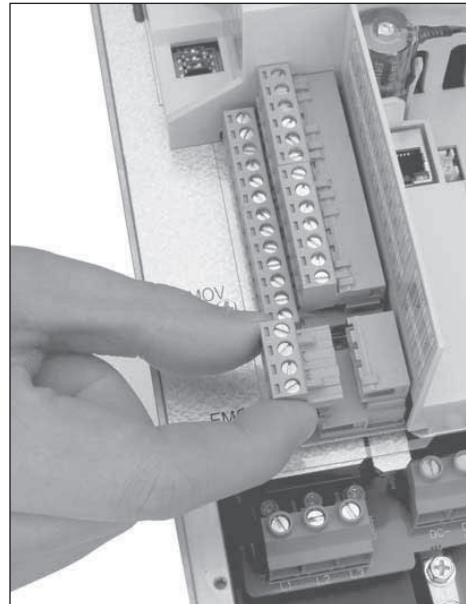

**Note:** For ease of access, the board terminals blocks can be unplugged for wiring.

8. Wire control to the control board

**Note:** Drive default is programmed for external interlock.

**I/O Connection**

- Run 240 Vac and 24 Vdc control wiring in separate conduit
- Communication wire to be shielded

**Table 37. DG1 I/O connection**



**External Wiring**

Pin	Signal name	Signal	Default setting	Description
1	+10 V	Ref. Output voltage	—	10 Vdc supply source
2	AI1+ ②	Analog input 1	0–10 V	Voltage speed reference (programmable to 4 mA to 20 mA)
3	AI1–	Analog input 1 ground	—	Analog input 1 common (ground)
4	AI2+ ②	Analog input 2	4 Ma to 20 ma	Current speed reference (programmable to 0–10 v)
5	AI2–	Analog input 2 ground	—	Analog input 2 common (ground)
6	GND	I/O signal ground	—	I/O ground for reference and control
7	DIN5	Digital input 5	Preset speed b0	Sets frequency output to preset speed 1
8	DIN6	Digital input 6	Preset speed b1	Sets frequency output to preset speed 2
9	DIN7	Digital input 7	Emergency stop (ti–)	Input forces VFD output to shut off
10	DIN8	Digital input 8	Force remote (ti+)	Input takes VFD from local to remote
11	CMB	Di5 to di8 common	Grounded	Allows source input
12	GND	I/O signal ground	—	I/O ground for reference and control
13	24 V	+24 Vdc output	—	Control voltage output (100 mA max.)
14	DO1	Digital output 1	Ready	Shows the drive is ready to run
15	24 Vo	+24 Vdc output	—	Control voltage output (100 mA max.)
16	GND	I/O signal ground	—	I/O ground for reference and control
17	AO1+	Analog output 1	Output frequency	Shows output frequency to motor 0–60 hz (4 mA to 20 mA)
18	AO2+	Analog output 2	Motor current	Shows motor current of motor 0–fla (4 mA to 20 mA)
19	24 Vi	+24 Vdc input	—	External control voltage input
20	DIN1	Digital input 1	Run forward	Input starts drive in forward direction (start enable)
21	DIN2	Digital input 2	Run reverse	Input starts drive in reverse direction (start enable)
22	DIN3	Digital input 3	External fault	Input causes drive to fault
23	DIN4	Digital input 4	Fault reset	Input resets active faults
24	CMA	Di1 to di4 common	Grounded	Allows source input
25	A	Rs-485 signal a	—	Fieldbus communication (modbus, bacnet)
26	B	Rs-485 signal b	—	Fieldbus communication (modbus, bacnet)
27	R3NO	Relay 3 normally open	At speed	Relay output 3 shows VFD is at ref. Frequency
28	R1NC	Relay 1 normally closed	Run	Relay output 1 shows VFD is in a run state
29	R1CM	Relay 1 common	—	—
30	R1NO	Relay 1 normally open	—	—
31	R3CM	Relay 3 common	At speed	Relay output 3 shows VFD is at ref. Frequency
32	R2NC	Relay 2 normally closed	Fault	Relay output 2 shows VFD is in a fault state
33	R2CM	Relay 2 common	—	—
34	R2NO	Relay 2 normally open	—	—

① The above wiring demonstrates a SINK configuration. It is important that CMA and CMB are wired to ground (as shown by dashed line). If a SOURCE configuration is desired, wire 24 V to CMA and CMB and close the inputs to ground. When using the +10 V for AI1, it is important to wire AI1—to ground (as shown by dashed line). If using +10 V for AI1 or AI2, terminals 3, 5, and 6 need to be jumpered together.  
 ② AI1+ and AI2+ use a 10k pot for 0–10 V.

## Chapter 6—Installation requirements

**Table 38. DH1 I/O connection**

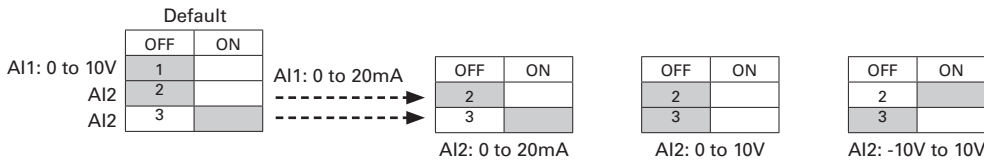

External Wiring	Pin	Signal Name	Signal	Default Setting	Description
	1	+10V	Ref. Output Voltage	-	10VDC Supply Source
	2	AI1+ ⊕	Analog Input 1	0-10V	Voltage Speed Reference (Programmable to 4-20mA)
	3	AI1-	Analog Input 1 Ground	-	Analog Input 1 Common (Ground)
	4	AI2+⊕	Analog Input 2	4-20mA	Current Speed Reference (Programmable to 0-10V)
	5	AI2-	Analog Input 2 Ground	-	Analog Input 2 Common (Ground)
	6	GND	I/O Signal Ground	-	I/O Ground for Reference and Control
	7	DIN5	Digital Input 5	Preset Speed B0	Sets frequency output to Preset Speed 1
	8	DIN6	Digital Input 6	Fire Mode	Enables drive into Fire Mode
	9	DIN7	Digital Input 7\TI+	Bypass Start	Enables drive into Bypass mode waiting for drive start
	10	DIN8	Digital Input 8\TI-	Force Auto	Input forces drive into Auto Control place
	11	CMB	DI5 to DI8 Common	Grounded	Allows source input
	12	GND	I/O Signal Ground	-	I/O Ground for Reference and Control
	13	24Vo	+24VDC Output	-	Control voltage output (100mA Max)
	14	DO1	Digital Output 1	Ready	Shows the drive is ready to run
	15	24Vo	+24VDC Output	-	Control voltage output (100mA Max)
	16	GND	I/O Signal Ground	-	I/O Ground for Reference and Control
	17	AO1+	Analog Output 1	Output Frequency	Shows Output frequency to motor 0 - 60Hz (4-20mA)
	18	AO2+	Analog Output 2	Motor Current	Shows Motor current of motor 0-FLA (4-20mA)
	19	24Vi	+24VDC Input	-	External control voltage input
	20	DIN1	Digital Input 1	Run Forward	Input starts drive in forward direction (start enable)
	21	DIN2	Digital Input 2	Run Reverse	Input starts drive in reverse direction(start enable)
	22	DIN3	Digital Input 3	External Fault	Input causes drive to fault
	23	DIN4	Digital Input 4	Fault Reset	Input resets active faults
	24	CMA	DI1 to DI4 Common	Grounded	Allows source input
	25	A	RS-485 Signal A/+	-	Fieldbus Communication (Modbus, BACnet)
	26	B	RS-485 Signal B/-	-	Fieldbus Communication (Modbus, BACnet)
	27	R3NO	Relay 3 Normally Open	Fault	Relay output 3 shows VFD is Faulted
	28	R1NC	Relay 1 Normally Closed	Bypass Run	Relay output 1 shows VFD is in a bypass run state
	29	R1CM	Relay 1 Common		
	30	R1NO	Relay 1 Normally Open		
	31	R3CM	Relay 3 Common	Fault	Relay output 3 shows VFD is Faulted
	32	R2NC	Relay 2 Normally Closed	Run	Relay output 2 shows VFD is in a drive run state
	33	R2CM	Relay 2 Common		
	34	R2NO	Relay 2 Normally Open		

**Note:** The above wiring demonstrates a SINK configuration. It is important that CMA and CMB are wired to ground (as shown by dashed line). If a SOURCE configuration is desired, wire 24 V to CMA and CMB and close the inputs to ground. When using the +10 V for AI1, it is important to wire AI1—ground (as shown by dashed line). If using +10 V for AI1 or AI2, terminals 3, 5, and 6 need to be jumpered together.  
 ⊕ AI1+ and AI2+ Support 10K potentiometer.





Figure 26. Basic internal control wiring diagram

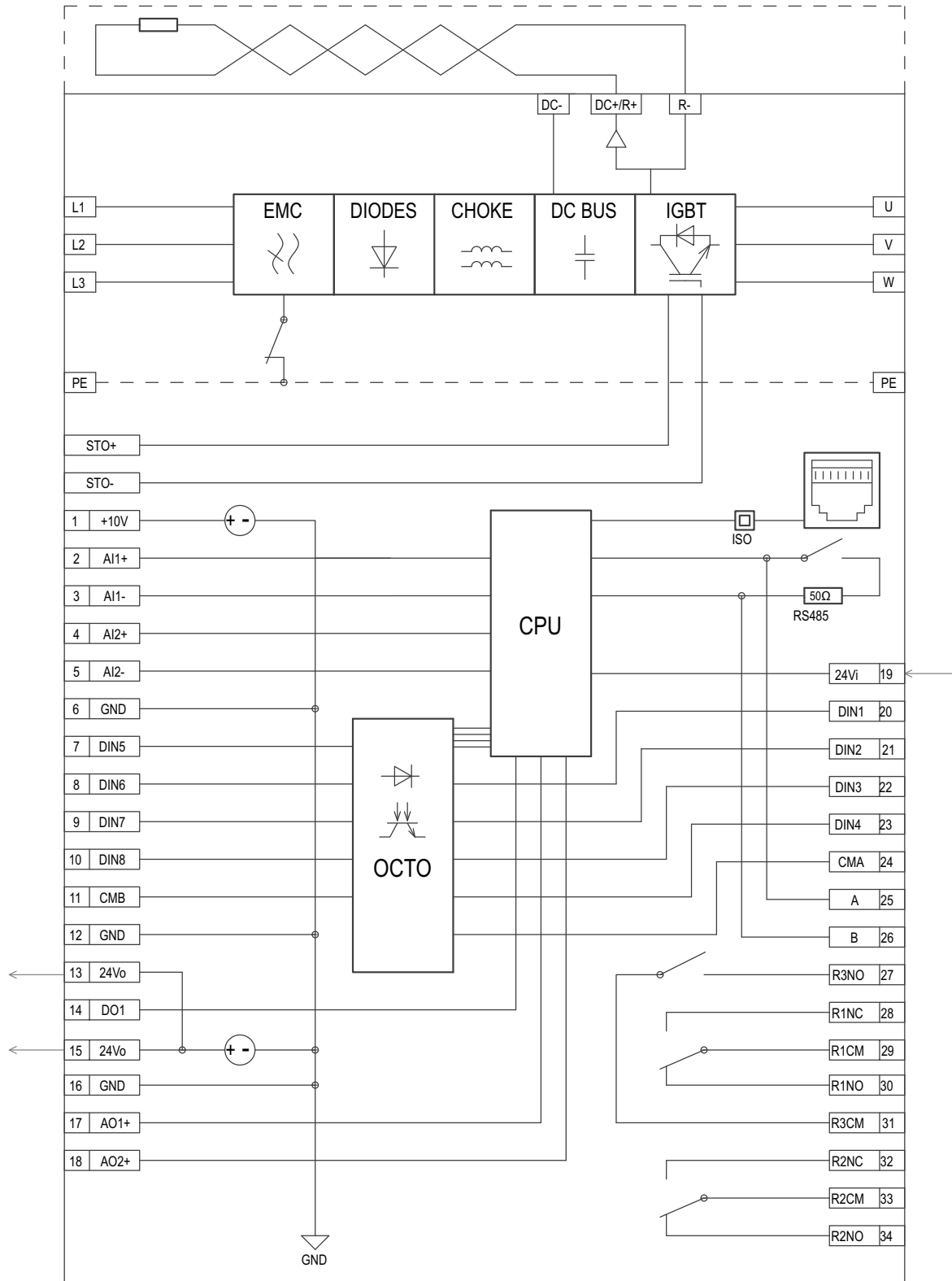

### Control board

The main PowerXL Series VFD consists of a main control board, control I/O connections block and two slots for extra option boards.

**Figure 27. PowerXL variable frequency drive**

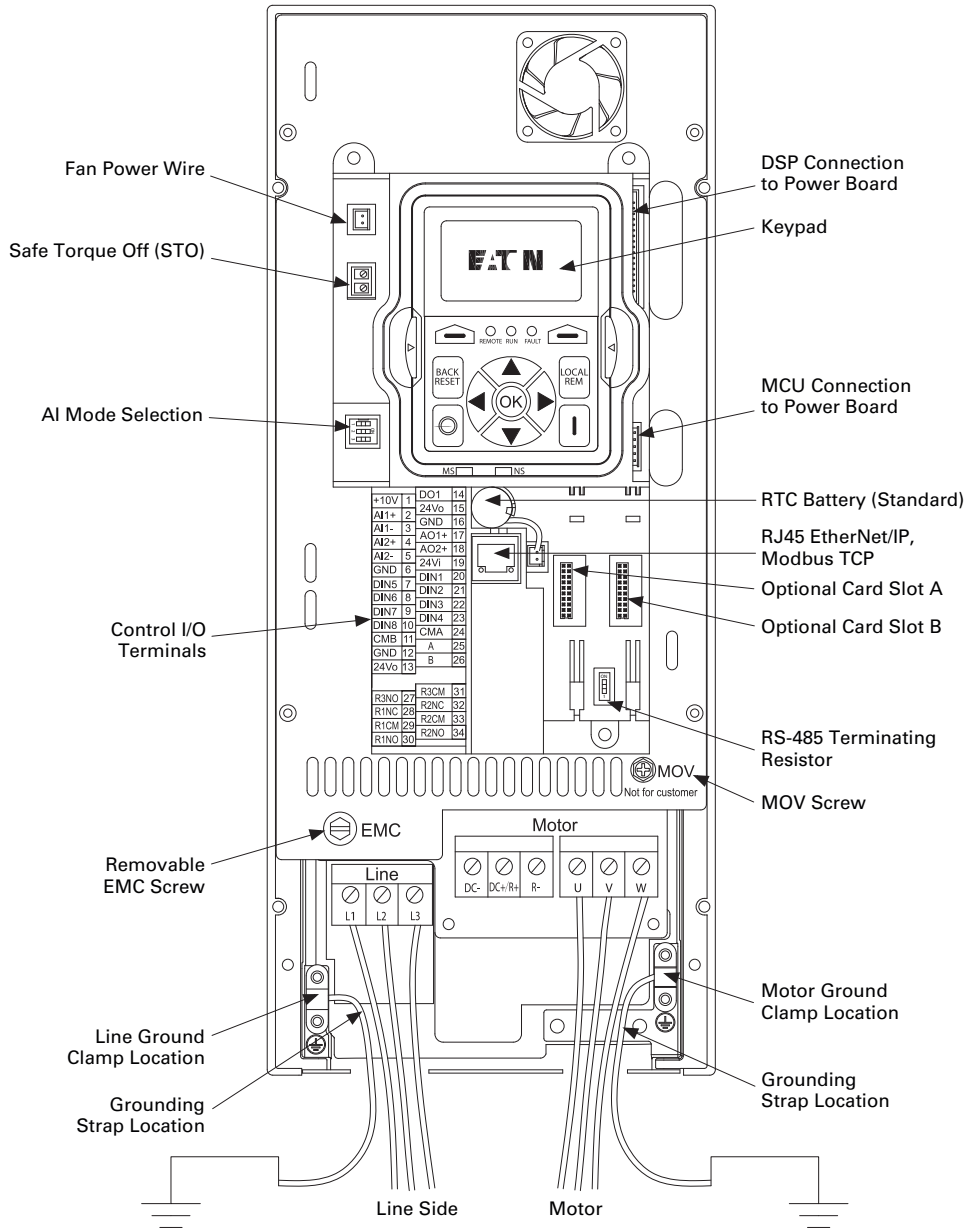

**Note:** This is a representation showing location of items. Location may be slightly different depending on frame size.

**Control wiring**

- All control I/O wiring is recommended to be segregated from line (mains) and motor cabling
- Control wiring shall be shielded twisted pairs to meet EMC levels required by IEC/EN 61800-3 (2004) + A1 (2012)
- Run 240 Vac and +24 Vdc control I/O in separate conduit
- Control I/O terminals must be tightened to 4.5 in-lb (0.5 Nm)
- Wiring or ferrule size: 28~12 (Sol) AWG, 30~12 (Str) AWG, or 0.2~2.5 mm<sup>2</sup>

**Safe torque off (STO)**

Refer to Appendix E for details of STO.

The PowerXL Series includes Safe Torque Off (STO) functionality as standard and provides:

- Isolation from the control board will stop IGBT from firing
- Functional safety SIL1 certification: IEC/EN 61800-5-2 and DIN EN ISO 13849-1, Performance Level C

**Connection to power section**

Figure 28 shows the general connections for the frequency inverter in the power section.

**Three-phase input connection**

Figure 28. Connection to power section

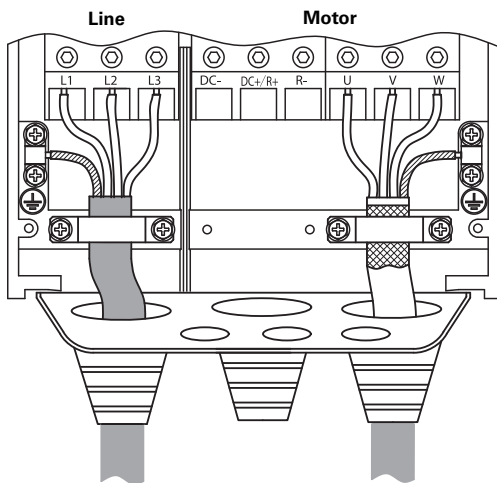

**Terminal designations in the power section**

- L1, L2, L3: Connection terminals for the supply voltage (input, input voltage)
- U, V, W: Connection terminals for the three-phase line to the AC motor (output, frequency inverter)
- PE: Connection for protective ground (reference potential). PES with mounted cable routing plate for shielded cables

**Ground connection**

The ground connection is connected directly with the cable clamp plates.

The shielded cables between the frequency inverter and the motor should be as short as possible. Connect the shielding on both ends and over a large surface area with protective ground PES (Protective Earth Shielding). You can connect the shielding of the motor cable directly to the cable clamp plate (360 degrees coverage) with the protective ground.

The frequency inverter must always be connected to the ground potential via a grounding cable (PE).

Figure 29. Grounding

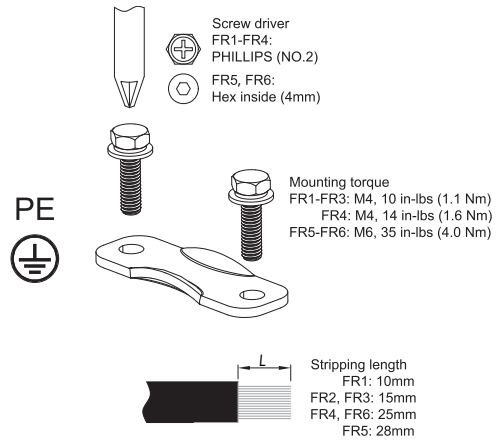

**Figure 30. FR0 grounding**

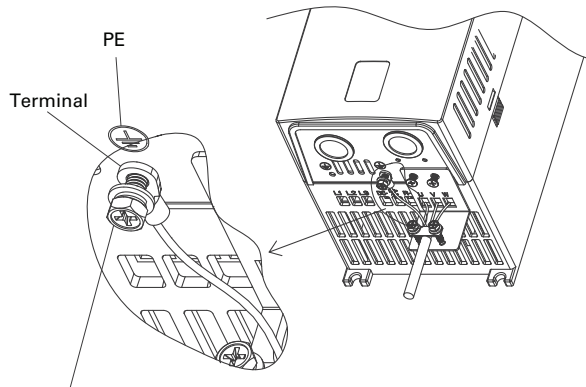

Mounting torque  
FR0: M4\*10, 14 in-lb (1.6 Nm)



**CAUTION**

Before connecting the AC drive to mains make sure that the EMC protection class settings of the drive are appropriately made.

**Note:** After having performed the change write “EMC level modified” on the sticker included in the PowerXL Series delivery (see **Figure 31**) and note the date. Unless already done, attach the sticker close to the name plate of the AC drive.

**Product modified sticker**

**Figure 31. Product modified sticker**

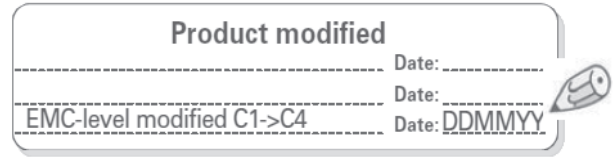

**Checking the cable and motor insulation**

1. Check the motor cable insulation as follows:
  - Disconnect the motor cable from terminals U, V and W of the PowerXL Series drive and from the motor
  - Measure the insulation resistance of the motor cable between each phase conductor as well as between each phase conductor and the protective ground conductor
  - The insulation resistance must be >1M ohm
2. Check the input power cable insulation as follows:
  - Disconnect the input power cable from terminals L1/N, L2/N and L3 of the PowerXL Series drive and from the utility line feeder
  - Measure the insulation resistance of the input power cable between each phase conductor as well as between each phase conductor and the protective ground conductor
  - The insulation resistance must be >1M ohm
3. Check the motor insulation as follows:
  - Disconnect the motor cable from the motor and open any bridging connections in the motor connection box
  - Measure the insulation resistance of each motor winding. The measurement voltage must equal at least the motor nominal voltage but not exceed 1000 V
  - The insulation resistance must be >1M ohm

### Chapter 7—EMC installation

**Note:** All following information is strongly recommended but is not necessary if sufficient system design and validation has been completed.

The responsibility to meet the local system EMC limit values and electromagnetic compatibility requirements is the responsibility of the end user or the system operator. This operator must also take measures to minimize or remove emissions in the environment concerned (see figure on **Page 49**). He must also use means to increase the interference immunity of the system devices.

In a drive system (PDS) with frequency inverters, you should take measures for electromagnetic compatibility (EMC) while doing your planning, because changes or improvements to the installation site, which are required in the installation or while mounting, are normally associated with additional higher costs.

The technology and system of a frequency inverter cause the flow of high frequency leakage current during operation. All grounding measures must therefore be implemented with low impedance connections over a large surface area.

With leakage currents greater than 3.5 mA, in accordance with VDE 0160 or EN 61800-5-1, either

- the protective conductor must have a cross-section of at least 10 mm<sup>2</sup>
- the protective conductor must be open-circuit monitored, and the supply must be automatically disconnected in case of discontinuity of the protective earthing conductor, or
- the second protective conductor must be fitted

For an EMC-compliant installation, we recommend the following measures:

- Installation of the frequency inverter in a metallic, electrically conducting enclosure with a good connection to earth
- Shielded motor cables (short cable lengths)
- Ground all conductive components and housings in a drive system using as short a line as possible with the greatest possible cross-section (Cu-braid)

#### EMC Measures in the control panel

For EMC-compatible installation, connect all metallic parts of the device and the switching cabinet together over broad surfaces and so that high-frequencies will be conducted. Mounting plates and cabinet doors should make good contact and be connected with short HF-braided cables. It is recommended to avoid using painted surfaces (anodized, chromized). An overview of all EMC measures is provided in the figure on **Page 49**.

Install the frequency inverter as directly as possible (without spacers) on a metal plate (mounting plate).

Route input and motor cables in the switch cabinet as close to the ground potential as possible. This is because free moving cables act as antennas.

When laying HF cables (for example, shielded motor cables) or suppressed cables (for example, input supply cables, control circuit and signal cables) in parallel, a minimum clearance of 11.81 in (300 mm) is recommended in order to prevent the radiation of electromagnetic energy. Separate cable routing is also recommended when large voltage potential differences are involved. Any necessary crossed cabling between the control signal and power cables should be implemented at right angles (90 degrees).

It is recommended to never lay control or signal cables in the same duct as power cables. Analog signal cables (measured, reference and correction values) should be shielded.

#### Earthing

The ground connection (PE) in the cabinet should be connected from the input supply to a central earth point (mounting plate). All protective conductors should be routed in star formation from this earth point and all conductive components of the PDS (frequency inverter, motor reactor, motor filter, main choke) are to be connected.

Avoid ground loops when installing multiple frequency inverters in one cabinet. Make sure that all metallic devices that are to be grounded have a broad area connection with the mounting plate.

#### Screen earth kit

Cables that are not shielded work like antennas (sending, receiving). Make sure that any cables that may carry disruptive signals (for example, motor cables) and sensitive cables (analog signal and measurement values) are shielded apart from one another with EMC-compatible connections.

The effectiveness of the cable shield depends on a good shield connection and a low shield impedance.

It is recommended to use only shields with tinned or nickel-plated copper braiding. Braided steel shields are unsuitable.

Control and signal lines (analog, digital) should be grounded on one end, in the immediate vicinity of the supply voltage source (PES).

### Installation requirements

Figure 34. EMC-Compliant Setup—230 Vac, 460/480 Vac, 600 Vac

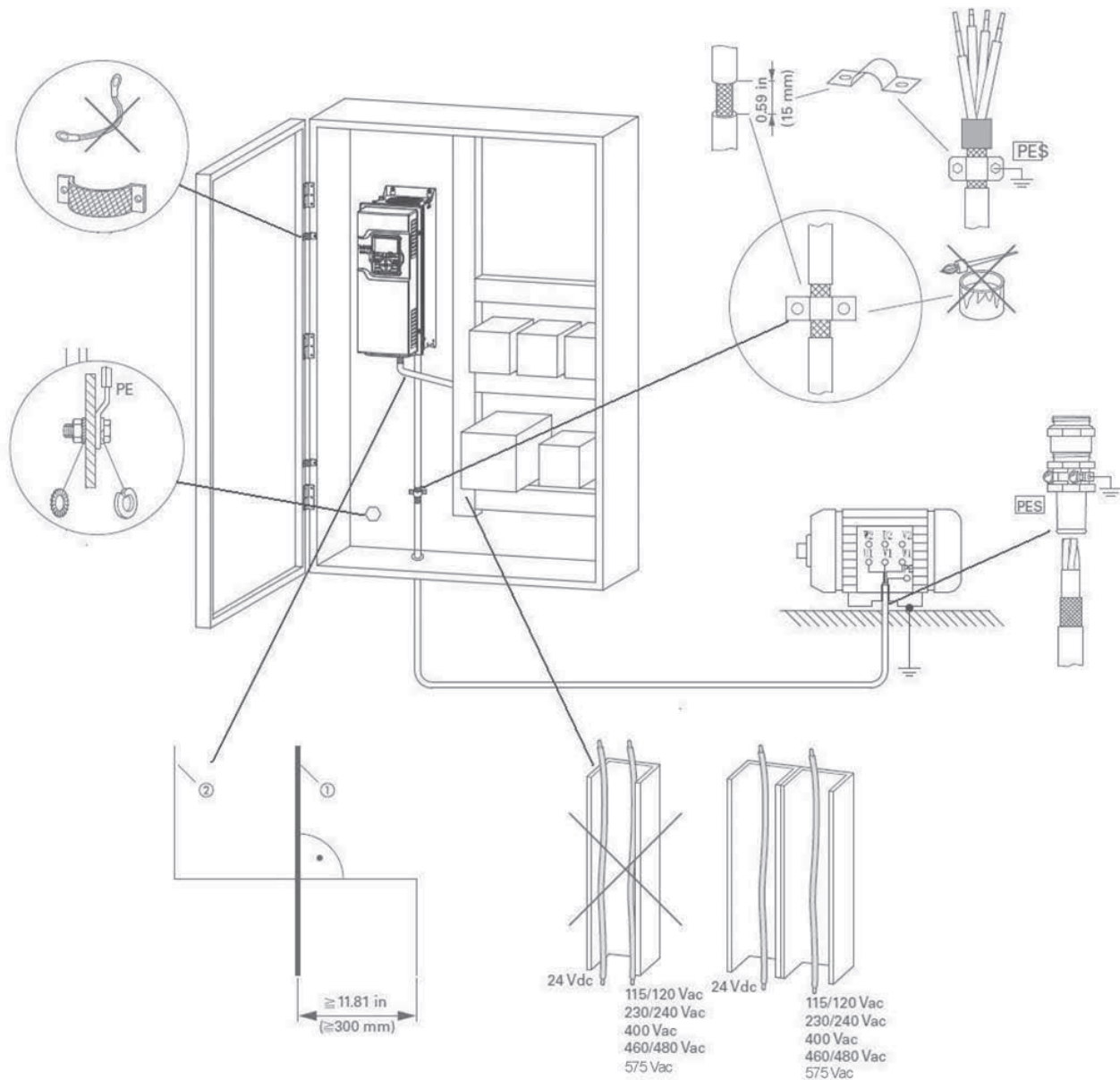

- Notes:**
- ① Power cable: L1, L2, L3 and U, V, W.
  - ② Control and signal lines: 1 to 36, fieldbus connection
- Large-area connection of all metallic control panel components. Mounting surfaces of frequency inverter and cable shielding must be free from paint. Connect the cable shielding in the output of the frequency inverter with a large surface area contact to the ground potential (PES). Large-area cable shield contacts with motor. Large-area earth connection of all metallic parts.

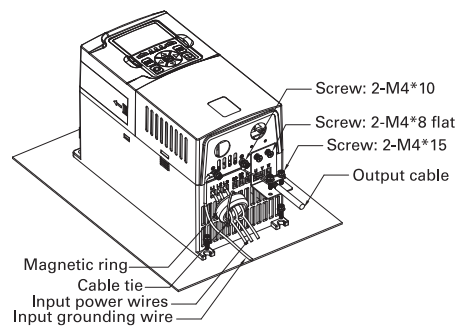

### International EMC protection cable requirements

The screened cables between the variable frequency drive and the motor should be as short as possible.

- Connect the screening, on both sides and across a large area (360° overlap), to the protective earth (PE). The power screening protective earth (PES) connection should be in the immediate proximity of the variable frequency drive and directly on the motor terminal box
- Prevent the screening from becoming unbraided, e.g., by pushing the opened plastic sheath over the end of the screening or with a rubber grommet on the end of the screening. As an alternative, in addition to a broad area cable clip, you can also twist the shielding braid at the end and connect to protective ground with a cable clip. To prevent EMC disturbance, this twisted shielding connection should be made as short as possible
- Screened three- or four-wire cable is recommended for the motor cables. The green/yellow line of a four-wire cable connects the protective ground connections from the motor and the variable frequency drive and therefore minimizes the equalizing current loads on the shielding braid
- If there are additional subassemblies in a motor feeder (such as motor contactors, overload relays, motor reactor, sinusoidal filters or terminals), the shielding of the motor cable can be interrupted close to these subassemblies and connected to the mounting plate (PES) with a large area connection

Free or non-screened connection cables should not be any longer than about 300 mm.

**Table 40. 1st Environment 2nd environment EMC levels according to EN 61800-3 (2004) ①**

Cable Type	Category C2	Category C3	Category C4 ②
Line voltage/mains	1	1	1
Motor cable	3 ③	2	2
Control cable	4	4	4

- Notes:**
- ① For EMC Class 2 requirements on FR0 PowerXL Series drive, use provided ferrite core with input wires going through it twice, so there is a loop on the core.
  - ② For installations in IT systems, it is necessary to modify the EMC protection to EMC level C4. See the following page for the procedure.
  - ③ 360° earthing of the shield with cable glands in motor end needed for EMC Level C2. See the following page for the procedure.

**Table 41. Motor power cable EMC guidelines**

Item	Directive
Product	IEC 61800-2
Safety	UL 508C, IEC/EN 61800-5-1
EMC (at default settings)	Immunity (EMS): IEC/EN 61800-3, 2nd environment Radiated and Conducted emissions (EMI): IEC/EN 61800-3 230/480V Series: Category C1: is possible with external filter connected to drive. Please consult factory Category C2: with internal filter maximum of 10 m motor cable length (FR0: This is obtained with 2 turns on a ferrite core and using metal ground plate) Category C3: with internal filter maximum of 50 m motor cable length (FR0: This is obtained with no ferrite core and metal plate) 575V Series: Category C3: with internal filter maximum of 10 m motor cable length

**Table 42. Cable categories**

Cable category	Description (All cables are rated for the specific operating voltage)
1	Intended for fixed installation
2	Symmetrical power cable equipped with a concentric protection wire.
3	Symmetrical power cable with compact low-impedance shield. Recommended cable transfer impedance of 1–30 MHz max. See figure below.
4	Screened cable equipped with compact low-impedance shield

**Figure 35. Cable description**

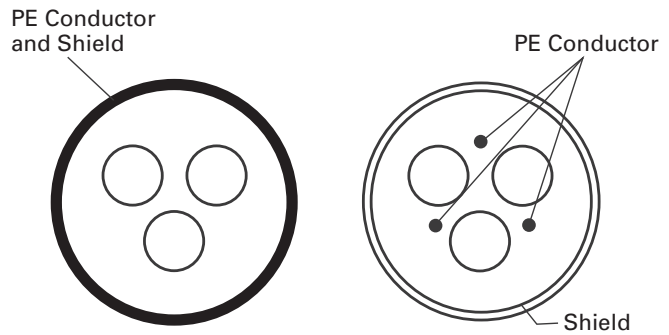



### Installation in corner-grounded network and IT system

Corner grounding and IT system are allowed for all the drive types.

In these circumstances the EMC protection class must be changed to level C4. This is done by removing the built-in EMC Screw with a simple procedure described below.

In addition on FR2 and FR4 the MOV screw is required to be removed, see **Figure 38**.

---

**WARNING**

---

**Do not perform any modifications on the AC drive when it is connected to mains.**

---

**WARNING**

---

**Electric shock hazard—risk of injuries! Carry out wiring work only if the unit is de-energized.**

**After disconnecting the supply, wait at least five minutes before removing the cover to allow the intermediate circuit capacitors to discharge.**

---

**WARNING**

---

**Failure to follow these instructions will result in death or serious injury.**

Remove the main cover of the AC drive and remove the EMC/MOV screws depending on frame size (see **Figure 36–Figure 39**). Once the screw is removed, it can be reconnected to re-engage the EMC protection.

**Figure 36. Location of the EMC Screw in Frame 0**

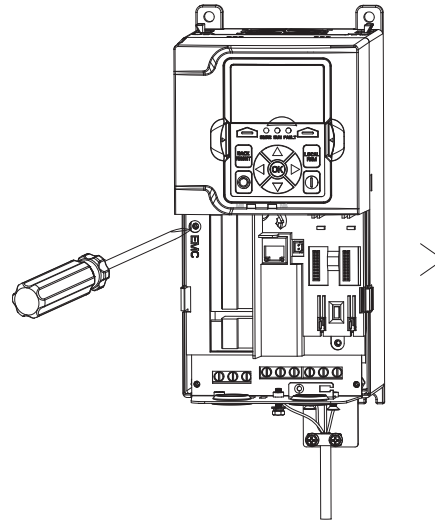

**Figure 37. Locations of the EMC Screw in Frame 1 and Frame 3**

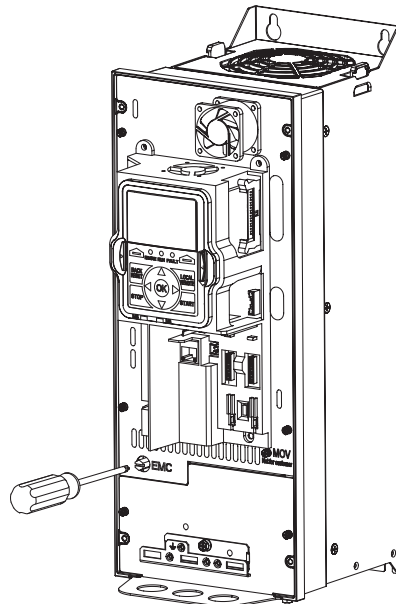

Figure 38. Locations of EMC and MOV Screws for Frame 2 and Frame 4

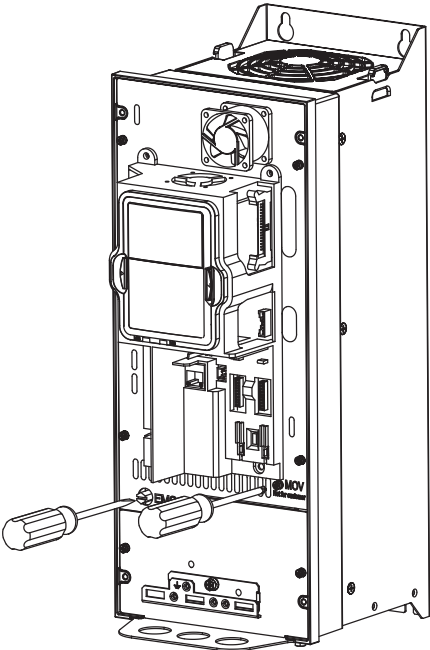
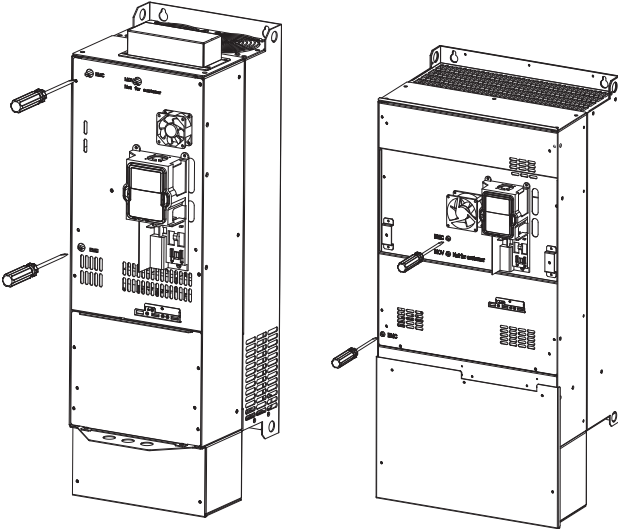

Figure 39. Locations of the EMC Screws in Frame 5 and Frame 6



## Appendix A—Technical data and specifications

### Technical data

**Table 43. PowerXL Series**

Attribute	Description	Specification	
Input ratings	Input voltage $U_{in}$	208 V to 240 V, 380 V to 500 V, 525 V to 600 V, -15 to 10%	
	Input frequency	50 Hz to 60 Hz (variation up to 45 Hz to 66 Hz)	
	Connection to power	Once per minute or less	
	Starting delay	3 s (FR0 to FR2), 4 s (FR3), 5 s (FR4), 6 s (FR5 and FR6)	
	Short-circuit withstand rating	100 kAIC (fuses and circuit breakers)	
Output ratings	Output voltage	0 to $U_{in}$	
	Continuous output current	$I_L$ : ambient temperature maximum 40 °C, up to 60 °C with derating, overload 1.1 x $I_L$ (1 min./10 min.) $I_H$ : ambient temperature maximum 50 °C, up to 60 °C with derating, overload 1.5 x $I_H$ (1 min./10 min.)	
	Overload current	150% respectively 110% (1 min./10 min.)	
	Initial output current	200% (2 s / 20 s) based of the drives rated nameplate $I_H$ current rating.	
	Output frequency	0–400 Hz (standard)	
	Frequency resolution	0.01 Hz	
Control characteristics	Control methods	Frequency control Speed control Open-loop speed control Open-loop torque control	
	Switching frequency	230 V / 480 V Range: FR0–3: 1 kHz to 12 kHz FR4–6: 1 kHz to 10 kHz 230 V / 480 V defaults: FR0–3: 4 kHz FR4–5: 3.6 kHz FR6: 2 kHz 600 V range: FR1–6: 1 kHz to 6 kHz 600 V defaults: FR1–6: 1.5 kHz Automatic switching frequency derating in case of overload.	
	Frequency reference	Analog input: resolution 0.1% (10-bit), accuracy +1% Analog output: resolution 0.1% (10-bit), accuracy +1% Panel reference: resolution 0.01 Hz	
	Field weakening point	20 Hz to 400 Hz	
	Acceleration time	0.1 s to 3000 s	
	Deceleration time	0.1 s to 3000 s	
	Braking torque	DC brake: 30% x Motor Rated Torque ( $T_n$ ) (without brake chopper) Dynamic braking (with optional brake chopper using an external brake resistor): 100% continuous maximum rating	
	Ambient conditions	Ambient operating temperature	-10 °C (no frost) to +50 °C, up to +60 °C with derating (CT) -10 °C (no frost) to +40 °C, up to +60 °C with derating (VT)
		Storage temperature	-40 °C to +70 °C
		Relative humidity	0–95% RH, noncondensing, non-corrosive
Air quality: • Chemical vapors • Mechanical particles		Tested according to IEC 60068-2-60 Test Key: Flowing mixed gas corrosion test, Method 1 (H <sub>2</sub> S [hydrogen sulfide] and SO <sub>2</sub> [sulfur dioxide]) Designed according to: IEC 60721-3-3, unit in operation, class 3C2 IEC 60721-3-3, unit in operation, class 3S2	

## Appendix A—Technical data and specifications

**Table 43. PowerXL Series, continued**

Attribute	Description	Specification
Ambient conditions, continued	Altitude	100% load capacity (no derating) up to 3280 ft (1000 m); 1% derating for each 328 ft (100 m) above 3280 ft (1000 m); max. 9842 ft (3000 m) (2000 m for corner grounded earth main systems) For 600 V product, maximum altitude is 2000 m regardless of main system
	Vibration: • EN 61800-5-1 • EN 60068-2-6	5–150 Hz Displacement amplitude: 1 mm (peak) at 5 Hz to 15.8 Hz (FR0–FR6) Maximum acceleration amplitude: 1g at 15.8 Hz to 150 Hz (FR0–FR6)
	Shock: • ISTA 1 A • EN 60068-2-27	Storage and shipping: maximum 15 g, 11 ms (in package)
	Overvoltage	Overvoltage Category III
	Pollution degree	Pollution Degree 2
	Enclosure class	FR0: Open Type /IP20 FR1–FR6: IP21/Type 1 standard in entire kW/hp range IP54/Type 12 option Note: Keypad or keypad hole plug required to be mounted in drive for IP54/Type 12 rating
	Immunity	Fulfills IEC/EN 61800-3 (2004) + A1 (2012), first and second environment
	MTBF	FR0: 150,000 hours FR1: 165,457 hours FR2: 134,833 hours FR3: 102,515 hours FR4: 121,567 hours FR5: 108,189 hours FR6: 100,000 hours
	Noise	FR0: 51.7 dB FR1: 51.2 dB FR2: 58.6 dB FR3: 61.0 dB FR4: 68.0 dB FR5: 69.1 dB FR6: 73.2dB
	Standards	Safety
EMC		IEC/EN 61800-3 (2004) + A1 (2012) 230/480V Series: Category C2 575V Series: Category C3 The drive can be modified for IT networks and corner grounding TN system
Electrostatic discharge		Second environment, IEC 61000-4-2, 4 kV CD or 8 kV AD, Criterion B
Fast transient burst		Second environment, IEC 61000-4-4, 2 kV/5 kHz, Criterion B
Dielectrical strength		Primary to secondary: 230 V: 4240 Vdc 480 V: 5100 Vdc 600 V: 5100 Vdc Primary to earth: 230 V: 2130 Vdc 480 V: 2830 Vdc 600 V: 3111 Vdc
Approvals		CE, UL and cUL, EAC, RCM (C-Tick), RoHS (see nameplate for more detailed approvals)
Fieldbus connections	Onboard DG1: EtherNet/IP, Modbus <sup>®</sup> TCP, Modbus RTU, BACnet Onboard DH1: Modbus TCP, BACnet/IP, Modbus RTU, BACnet	

**Table 43. PowerXL Series, continued**

<b>Attribute</b>	<b>Description</b>	<b>Specification</b>
Safety/protections	Overvoltage protection	Yes
	Overvoltage trip limit	230 V drives: 456 V 480 V drives: 911 V 600 V drives: 1100 V
	Undervoltage protection	Yes
	Undervoltage trip limit	230 V drives: 211 V 480 V drives: 370 V 600 V drives: 550 V
	Earth fault protection	Yes, Default: 15% Motor FLA Min: 0% Motor FLA Max: 30% Motor FLA
	Input phase supervision	Yes
	Motor phase supervision	Yes
	Overcurrent protection	Yes
	Unit overtemperature protection	Yes
	Motor overload protection	Yes
	Motor stall protection	Yes
	Motor underload protection	Yes
	DC bus overvoltage control	Yes
	Short-circuit protection of 24 V reference voltages	Yes
	Surge protection	Yes (differential mode 2 kV; common mode 4 kV 230 V drives: 275 Vac, 10,000 A 480 V drives: 320 Vac, 8000 A 600 V drives: 385 Vac, 10,000 A
	Common coated boards	Yes (prevents corrosion)
	RTC Battery	3.6V Lithium Battery (Able ER14250) ROHS compliant Follow local Recycling program to dispose. 10,000 hour life *Only active when Power Removed
Efficiency	Drive efficiency ratings	230 V: FR0 = DG1-323D7EB-C20C: 96.37% DG1-324D8EB-C20C: 96.38% DG1-326D6EB-C20C: 96.31% FR1 = 96.7% FR2 = 97.4% FR3 = 97.2% FR4 = 97.4% FR5 = 97.7% FR6 = 97.5%  480 V: FR0 = DG1-342D2EB-C20C: 97.23% DG1-343D3EB-C20C: 97.33% DG1-344D3EB-C20C: 97.27% DG1-345D6EB-C20C: 97.15% FR1 = 97.7% FR2 = 97.9% FR3 = 97.7% FR4 = 98.0% FR5 = 98.2% FR6 = 97.9%  600 V: FR1 = 98.1% FR2 = 98.2% FR3 = 97.7% FR4 = 98.3% FR5 = 98.6% FR6 = 98.5%

## Appendix B—Installation guidelines

### Cable and fuse sizing

See **Page 40** for cable stripping guidelines.

**Table 44. North America cable and fuse sizes—208 Vac to 240 Vac ratings**

Frame size	CT Amp Suffix	VT Amp Suffix	208 V input current (CT/IH)	208 V input current (VT/IL)	NEC motor Amp rating at 230 V	NEC motor Amp rating at 208 V	Current (CT/IH) at 50 °C	Current (VT/IL) at 40 °C	Recommended fuse rating	NEC wire size (AWG)		Terminal connection size (AWG)	
										Line and motor	Ground	Line and motor	Ground
FR0	3D7	4D8	4.3	5.6	4.2	4.6	3.7	4.8	10	14	14	26–10	18–10
	4D8	6D6	5.6	7.6	6	6.6	4.8	6.6	10	14	14	26–10	18–10
	6D6	7D8	7.6	9	6.8	7.5	6.6	7.8	15	14	14	26–10	18–10
FR1	3D7	4D8	3.2	4.4	4.2	4.6	3.7	4.8	10	14	14	24–10	18–10
	4D8	6D6	4.4	6.1	6.0	6.6	4.8	6.6	10	14	14	24–10	18–10
	6D6	7D8	6.1	7.2	6.8	7.5	6.6	7.8	10	14	14	24–10	18–10
	7D8	011	7.2	10.2	9.6	10.6	7.8	11	15	14	14	24–10	18–10
	011	012	10.2	11.6	—	—	11	12.5	15	12	12	24–10	18–10
FR2	012	017	10.2	16.3	15.2	16.7	12.5	17.5	20	10	10	20–6	12–6
	017	025	16.2	23.2	22	24.2	17.5	25	30	8	10	20–6	12–6
	025	031	23.1	29	28	30.8	25	31	35	8	10	20–6	12–6
FR3	031	048	28.7	44.2	42	46.2	31	48	60	6	6	6–2	14–4
	048	061	44.4	56	54	59.4	48	61	80	4	6	6–2	14–4
FR4	061	075	56.4	64.6	68	74.8	61	75	100	3	4	6–1/0	10–1/0
	075	088	69.4	78	80	88	75	88	110	2	4	6–1/0	10–1/0
	088	114	81.4	94.3	104	114	88	114	125	1/0	3	6–1/0	10–1/0
FR5	114	143	105.5	129	130	143	114	143	175	3/0	3	1/0–350 kcmil	8–250 kcmil
	143	170	132.3	157	154	169	143	170	200	4/0	3	1/0–350 kcmil	8–250 kcmil
	170	211	157.3	189	192	211	170	211	250	300	3	1/0–350 kcmil	8–250 kcmil
FR6	211	261	196.3	242.8	248	273	211	261	400	2*2/0	3	2*(1/0–300 kcmil)	3–300 kcmil
	248	312	230.7	290.3	312	343	248	312	400	2*4/0	3	2*(1/0–300 kcmil)	3–300 kcmil

- Notes:**
- ① Line and motor cable size is selected according to UL508C Table 40.3 for copper conductor rated 75 °C. Use only with copper wire rated 75 °C here. Size requirements for other different wire types are defined in the National Electrical Code, ANSI/NFPA 70
  - ② Earthing conductor size is determined by the maximum overcurrent device rating used ahead of the drive according to UL508C Table 6.4
  - ③ If power cubes or bypass are used, a UL listed Class RK5, J, T, or equivalent fuse is recommended

Table 45. International cable and fuse sizes—208 Vac to 240 Vac ratings

Frame size	CT Amp Suffix	VT Amp Suffix	208 V input current (CT/IH)	208 V input current (VT/IL)	Current (CT/IH) at 50 °C	Current (VT/IL) at 40 °C	Fuse rating (gG/gL)	Mains and motor cable Cu (mm <sup>2</sup> )	Terminal cable size	
									Main terminal Cu (mm <sup>2</sup> )	Earth terminal Cu (mm <sup>2</sup> )
FR0	3D7	4D8	4.3	5.6	3.7	4.8	10	3*1.5+1.5	0.2–6 solid or 0.2–4 stranded	0.75–6
	4D8	6D6	5.6	7.6	4.8	6.6	10	3*1.5+1.5	0.2–6 solid or 0.2–4 stranded	0.75–6
	6D6	7D8	7.6	9	6.6	7.8	16	3*1.5+1.5	0.2–6 solid or 0.2–4 stranded	0.75–6
FR1	3D7	4D8	3.2	4.4	3.7	4.8	6	3*1.5+1.5	0.2–6 solid or 0.2–4 stranded	0.75–6
	4D8	6D6	4.4	6.1	4.8	6.6	10	3*1.5+1.5	0.2–6 solid or 0.2–4 stranded	0.75–6
	6D6	7D8	6.1	7.2	6.6	7.8	16	3*1.5+1.5	0.2–6 solid or 0.2–4 stranded	0.75–6
	7D8	011	7.2	10.2	7.8	11	16	3*1.5+1.5	0.2–6 solid or 0.2–4 stranded	0.75–6
	011	012	10.2	11.6	11	12.5	16	3*1.5+1.5	0.2–6 solid or 0.2–4 stranded	0.75–6
FR2	012	017	10.2	16.3	12.5	17.5	20	3*4+4	0.5–16	4–16
	017	025	16.2	23.2	17.5	25	32	3*4+4	0.5–16	4–16
	025	031	23.1	29	25	31	32	3*6+6	0.5–16	4–16
FR3	031	048	28.7	44.2	31	48	50	3*16+16	16–35	2.5–25
	048	061	44.4	56	48	61	63	3*16+16	16–35	2.5–25
FR4	061	075	56.4	64.6	61	75	80	3*25+16	16–50	6–50
	075	088	69.4	78	75	88	100	3*35+16	16–50	6–50
	088	114	81.4	94.3	88	114	125	3*50+25	16–50	6–50
FR5	114	143	105.5	129	114	143	160	3*70+35	50–185	10–120
	143	170	132.3	157	143	170	200	3*95+50	50–185	10–120
	170	211	157.3	189	170	211	250	3*150+95	50–185	10–120
FR6	211	261	196.3	242.8	211	261	400	2*(3*70+35)	2*(50–150)	35–150
	248	312	230.7	290.3	248	312	400	2*(3*95+50)	2*(50–150)	35–150

**Notes:** ① Line and motor cable size is selected according to IEC60364–5–52:2009 Table B.52.4 for copper conductor with PVC insulation with a wiring condition of ambient temperature 30 °C in air and an installation method of “B2” (cables in conduit and cable trunking systems). For other wiring conditions, please refer to the standard of IEC60364–5–52:2009 for suitable cable sizes

② Earthing conductor size is determined by the cross-sectional area of phase conductors according to IEC/EN61800–5–1:2007 Table 5. So if phase conductor size is changed, earthing conductor size should also be changed accordingly

③ If power cubes or bypass are used, a Class gG/gL fuse is recommended

## Appendix B—Installation guidelines

**Table 46. North America cable and fuse sizes—440 Vac to 500 Vac ratings**

Frame size	CT Amp Suffix	VT Amp Suffix	460 V input current (CT/IH)	460 V input current (VT/IL)	NEC motor Amp rating at 460 V	Current (CT/IH) at 50 °C	Current (VT/IL) at 40 °C	Recommended fuse rating	NEC wire size (AWG)		Terminal connection size (AWG)	
									Line and motor	Ground	Line and motor	Ground
FR0	2D2	3D3	2.6	3.8	3	2.1	3	10	14	14	26–10	18–10
	3D3	4D3	3.8	4.3	3.4	3	3.4	10	14	14	26–10	18–10
	4D3	5D6	4.3	6	4.8	3.4	4.8	10	14	14	26–10	18–10
	5D6	7D6	6	9.6	7.6	4.8	7.6	15	14	14	26–10	18–10
FR1	2D2	3D3	2	2.8	3.0	2.1	3.0	10	14	14	26–10	18–10
	3D3	4D3	2.8	3.2	3.4	3.0	3.4	10	14	14	26–10	18–10
	4D3	5D6	3.2	4.5	4.8	3.4	4.8	10	14	14	26–10	18–10
	5D6	7D6	4.5	7.1	7.6	4.8	7.6	10	14	14	26–10	18–10
	7D6	9D0	7.1	8.4	—	7.6	7.6	15	14	14	26–10	18–10
	9D0	012	8.4	10.2	11	7.6	11	15	14	14	26–10	18–10
FR2	012	016	10.2	13	14	11	14	20	12	12	20–6	12–6
	016	023	13	19.6	21	14	21	30	10	10	20–6	12–6
	023	031	19.5	25.2	27	21	27	35	8	8	20–6	12–6
FR3	031	038	25.1	31.7	34	27	34	50	6	8	6–2	14–4
	038	046	31.6	37	40	34	40	60	6	8	6–2	14–4
	046	061	37.2	48.1	52	40	52	80	4	6	6–2	14–4
FR4	061	072	48.3	59.3	65	52	65	100	4	4	6–1/0	10–1/0
	072	087	60.4	70.3	77	65	77	110	3	4	6–1/0	10–1/0
	087	105	71.6	87.6	96	77	96	125	1	3	6–1/0	10–1/0
FR5	105	140	89.2	114.4	124	96	124	175	2/0	3	1/0–350 kcmil	8–250 kcmil
	140	170	115.3	144	156	124	156	200	3/0	3	1/0–350 kcmil	8–250 kcmil
	170	205	145	166.1	180	156	180	250	250 kcmil	3	1/0–350 kcmil	8–250 kcmil
FR6	205	261	169.8	226.4	240	180	240	400	2*2/0	3	2*(1/0–300 kcmil)	3–300 kcmil
	245	310	226.4	284.9	302	240	302	400	2*4/0	3	2*(1/0–300 kcmil)	3–300 kcmil

- Notes:**
- ① Line and motor cable size is selected according to UL508C Table 40.3 for copper conductor rated 75 °C. Use only with copper wire rated 75 °C here. Size requirements for other different wire types are defined in the National Electrical Code, ANSI/NFPA 70
  - ② Earthing conductor size is determined by the maximum overcurrent device rating used ahead of the drive according to UL508C Table 6.4
  - ③ If power cubes or bypass are used, a UL listed Class RK5, J, T, or equivalent fuse is recommended



Table 47. International cable and fuse sizes—380 Vac to 440 Vac ratings

Frame size	CT Amp Suffix	VT Amp Suffix	400 V input current (CT/IH)	400 V input current (VT/IL)	Current (CT/IH) at 50 °C	Current (VT/IL) at 40 °C	Fuse rating (gG/gL)	Mains and motor cable Cu (mm <sup>2</sup> )	Terminal cable size	
									Main terminal Cu (mm <sup>2</sup> )	Earth terminal Cu (mm <sup>2</sup> )
FR0	2D2	3D3	2.7	4.3	2.2	3.3	6	3*1.5+1.5	0.2–6 solid or 0.2–4 stranded	0.75–6
	3D3	4D3	4.3	5.5	3.3	4.3	10	3*1.5+1.5	0.2–6 solid or 0.2–4 stranded	0.75–6
	4D3	5D6	5.5	7.1	4.3	5.6	10	3*1.5+1.5	0.2–6 solid or 0.2–4 stranded	0.75–6
	5D6	7D6	7.1	9.6	5.6	7.6	16	3*1.5+1.5	0.2–6 solid or 0.2–4 stranded	0.75–6
FR1	2D2	3D3	2.0	3.1	2.2	3.3	6	3*1.5+1.5	0.2–6 solid or 0.2–4 stranded	0.75–6
	3D3	4D3	3.1	4	3.3	4.3	6	3*1.5+1.5		0.75–6
	4D3	5D6	4	5.2	4.3	5.6	10	3*1.5+1.5	0.75–6	
	5D6	7D6	5.2	7.1	5.6	7.6	16	3*1.5+1.5	0.75–6	
	7D6	9D0	7.1	8.4	7.6	9	16	3*1.5+1.5	0.75–6	
	9D0	012	8.4	11.2	9	12	16	3*1.5+1.5	0.75–6	
FR2	012	016	11.2	15	12	16	20	3*4+4	0.5–16	4–16
	016	023	14.9	21.5	16	23	25	3*4+4	0.5–16	4–16
	023	031	21.4	29	23	31	32	3*6+6	0.5–16	4–16
FR3	031	038	28.8	35.2	31	38	40	3*16+16	16–35	2.5–25
	038	046	35.3	42.6	38	46	50	3*16+16	16–35	2.5–25
	046	061	42.8	55.7	46	61	63	3*16+16	16–35	2.5–25
FR4	061	072	56.7	65.7	61	72	80	3*25+16	16–50	6–50
	072	087	66.9	79.4	72	87	100	3*35+16	16–50	6–50
	087	105	80.9	97	87	105	125	3*50+25	16–50	6–50
FR5	105	140	97.6	129	105	140	160	3*70+35	50–185	10–120
	140	170	130.1	157	140	170	200	3*95+50	50–185	10–120
	170	205	158.0	189	170	205	250	3*120+70	50–185	10–120
FR6	205	261	193.4	246.2	205	261	400	2*(3*70+35)	2*(50–150)	35–150
	245	310	231.1	292.4	245	310	400	2*(3*95+50)	2*(50–150)	35–150

- Notes:**
- ① Line and motor cable size is selected according to IEC60364–5–52:2009 Table B.52.4 for copper conductor with PVC insulation with a wiring condition of ambient temperature 30 °C in air and an installation method of “B2” (cables in conduit and cable trunking systems). For other wiring conditions, please refer to the standard of IEC60364–5–52:2009 for suitable cable sizes
  - ② Earthing conductor size is determined by the cross-sectional area of phase conductors according to IEC/EN61800–5–1:2007 Table 5. So if phase conductor size is changed, earthing conductor size should also be changed accordingly
  - ③ If power cubes or bypass are used, a Class gG/gL fuse is recommended

## Appendix B—Installation guidelines

**Table 48. North America cable and fuse sizes—525 Vac to 600 Vac ratings ①②**

Frame size	CT Amp Suffix	VT Amp Suffix	575 V Input current (CT/IH)	575 V Input current (VT/IL)	NEC motor amp rating at 575 V	Current (CT/IH) at 50 °C	Current (VT/IL) at 40 °C	Recommended fuse rating ③	Nec wire size (AWG)		Terminal connection size (AWG)	
									Line and motor	Ground	Line and motor	Ground
FR1	3D3	4D5	3.1	4.2	3.9	3.3	4.5	10	14	14	26–10	18–10
	4D5	7D5	4.2	7	6.1	4.5	7.5	10	14	12	26–10	18–10
	7D5	010	7	9.3	9	7.5	10	15	14	10	26–10	18–10
FR2	010	013	9.3	12.5	11	10	13.5	20	12	10	20–6	12–6
	013	018	12.5	16.7	17	13.5	18	30	10	10	20–6	12–6
	018	022	16.7	20.4	22	18	22	35	10	8	20–6	12–6
FR3	022	027	20.4	25.2	27	22	27	40	6	8	6–2	14–4
	027	034	25.1	31.7	32	27	34	45	6	8	6–2	14–4
	034	041	31.6	38.2	41	34	41	50	6	6	6–2	14–4
FR4	041	052	38.1	48.1	52	41	52	70	4	6	6–1/0	10–1/0
	052	062	48.3	57.4	62	52	62	80	4	6	6–1/0	10–1/0
	062	080	57.6	73	77	62	80	125	2	4	6–1/0	10–1/0
FR5	080	100	74.4	91.3	99	80	100	150	1/0	4	1/0–350 kcmil	8–250 kcmil
	100	125	93	114.1	125	100	125	175	2/0	4	1/0–350 kcmil	8–250 kcmil
	125	144	116.2	132.9	144	125	144	200	3/0	4	1/0–350 kcmil	8–250 kcmil
FR6	144	208	140.4	202.8	192	144	208	400	2*1/0	3	2*(1/0–300 kcmil)	3–300 kcmil
	208	250	202.8	243.8	242	208	250	400	2*2/0	3	2*(1/0–300 kcmil)	3–300 kcmil

**Notes:** ① Line and motor cable size is selected according to UL 508C Table 40.3 for copper conductor rated 75 °C.

Use only with copper wire rated 75 °C here. Size requirements for other different wire types are defined in the National Electrical Code, ANSI/NFPA 70

② Earthing conductor size is determined by the maximum overcurrent device rating used ahead of the drive according to UL 508C Table 6.4

③ If power cubes or bypass are used, a UL listed Class RK5, J, T or equivalent fuse is recommended

## Temperature deratings

When using the PowerXL drives at elevated temperatures, derating is required to size the drive and maintain proper cooling. The following procedures and tables describe the process of derating and choosing the correct drive.

### Procedure

Certain operating parameters and conditions are required for correct derating. These are: voltage, torque application (variable or constant), operating temperature, enclosure rating, switching frequency, required amperage.

Follow the below steps to correctly derate the PowerXL drives.

1. Find the derating table (**Table 49–Table 54**) for the voltage and torque application.  
ex.) 480 V, Variable Torque = **Table 8**
2. Within the table, find the sections of rows for the application temperature and column for the switching frequency.  
ex.) 50 °C section, 4 kHz column
3. Look at all the frame sizes and find the frame size for your required amperage.  
ex.) FR1 = 9 A  
FR2 = 25 A  
FR3 = 51.8 A ← this is the frame size needed for the 37 A application  
FR4 = 89.9 A  
FR5 = 66.1 A
4. Take the derating % for that frame size and go to the catalog tables (**Table 2–Table 7**). Derate each option within that frame size to find the correct drive.  
ex.) the derating percentage is 84.9%  
DG1-34031FB-C21C: normal 38 A, derated to 84.9% = 32.3 A  
DG1-34038FB-C21C: normal 46 A, derated to 84.9% = 39.1 A ← this is the drive to select  
DG1-34046FB-C21C: normal 61 A, derated to 84.9% = 51.8 A

## Appendix B—Installation guidelines

**Table 49. 230 V temperature deratings (VT)**

Shading indicates default switching frequency for each frame size.

Variable torque (VT)/ low overload (I <sub>L</sub> )	Frame size	Maximum rated current (A), percentage of rated current											
		Switching frequency											
		1 kHz	2 kHz	3 kHz	3.6 kHz	4 kHz	5 kHz	6 kHz	7 kHz	8 kHz	9 kHz	10 kHz	12 kHz
Temperature													
40 °C	FR0	7.8 A (100%)	7.8 A (100%)	7.8 A (100%)	7.8 A (100%)	7.8 A (100%)	7.8 A (100%)	7.8 A (100%)	7.8 A (100%)	7.8 A (100%)	7.8 A (100%)	7.8 A (100%)	7.8 A (100%)
	FR1	12.5 A (100%)	12.5 A (100%)	12.5 A (100%)	12.5 A (100%)	12.5 A (100%)	12.5 A (100%)	12.5 A (100%)	12.1 A (96.8%)	11.7 A (93.6%)	11.3 A (90.4%)	10.9 A (87.2%)	10.1 A (80.8%)
	FR2	31 A (100%)	31 A (100%)	31 A (100%)	31 A (100%)	31 A (100%)	31 A (100%)	31 A (100%)	30.1 A (97.3%)	29.3 A (94.6%)	28.5 A (91.9%)	27.6 A (89.2%)	26 A (83.8%)
	FR3	61 A (100%)	61 A (100%)	61 A (100%)	61 A (100%)	61 A (100%)	61 A (100%)	61 A (100%)	61 A (100%)	61 A (100%)	61 A (100%)	61 A (100%)	61 A (100%)
	FR4	114 A (100%)	114 A (100%)	114 A (100%)	114 A (100%)	112.8 A (98.9%)	109.8 A (96.3%)	106.9 A (93.8%)	104 A (91.2%)	99.6 A (87.4%)	95.3 A (83.6%)	91 A (79.8%)	—
	FR5	211 A (100%)	211 A (100%)	211 A (100%)	211 A (100%)	206.5 A (97.8%)	195.3 A (92.5%)	184.1 A (87.2%)	173 A (81.9%)	165.3 A (78.3%)	157.6 A (74.7%)	150 A (71%)	—
	FR6	312 A (100%)	312 A (100%)	312 A (100%)	—	300 A (96.2%)	288 A (92.3%)	276 A (88.5%)	264 A (84.6%)	252 A (80.8%)	240 A (76.9%)	228 A (73.1%)	—
50 °C	FR0	7.8 A (100%)	7.8 A (100%)	7.8 A (100%)	7.8 A (100%)	7.8 A (100%)	7.8 A (100%)	7.8 A (100%)	7.7 A (98.7%)	7.6 A (97.4%)	7.5 A (96.2%)	7.4 A (94.9%)	7.2 A (92.3%)
	FR1	10.5 A (84%)	10.5 A (84%)	10.5 A (84%)	10.5 A (84%)	10.5 A (84%)	10.5 A (84%)	10.5 A (84%)	10.1 A (80.8%)	9.7 A (77.6%)	9.3 A (74.4%)	8.9 A (71.2%)	8.1 A (64.8%)
	FR2	27 A (87%)	27 A (87%)	27 A (87%)	27 A (87%)	27 A (87%)	27 A (87%)	27 A (87%)	26.1 A (84.4%)	25.3 A (81.7%)	24.5 A (79%)	23.6 A (76.3%)	22 A (70.9%)
	FR3	57 A (93.4%)	57 A (93.4%)	57 A (93.4%)	57 A (93.4%)	57 A (93.4%)	57 A (93.4%)	57 A (93.4%)	57 A (93.4%)	57 A (93.4%)	57 A (93.4%)	55.6 A (91.2%)	53 A (86.8%)
	FR4	100 A (87.7%)	100 A (87.7%)	100 A (87.7%)	100 A (87.7%)	98.8 A (86.6%)	95.8 A (84.1%)	92.9 A (81.5%)	90 A (78.9%)	86.6 A (76%)	83.3 A (73%)	80 A (70.1%)	—
	FR5	170 A (80.5%)	170 A (80.5%)	170 A (80.5%)	170 A (80.5%)	166.1 A (78.7%)	156.4 A (74.1%)	146.7 A (69.5%)	137 A (64.9%)	126.6 A (60%)	116.3 A (55.1%)	106 A (50.2%)	—
	FR6	260 A (83.3%)	250 A (80.1%)	240 A (76.9%)	—	230 A (73.7%)	220 A (70.5%)	210 A (67.3%)	200 A (64.1%)	190 A (60.9%)	180 A (57.7%)	170 A (54.5%)	—
60 °C	FR0	7.8 A (100%)	7.8 A (100%)	7.8 A (100%)	7.8 A (100%)	7.8 A (100%)	7.8 A (100%)	7.8 A (100%)	7.5 A (96.2%)	7.2 A (92.3%)	6.9 A (88.5%)	6.6 A (84.6%)	6 A (76.9%)
	FR1	8.5 A (68%)	8.5 A (68%)	8.5 A (68%)	8.5 A (68%)	8.5 A (68%)	8.5 A (68%)	8.5 A (68%)	8.2 A (65.8%)	7.9 A (63.7%)	7.7 A (61.6%)	7.4 A (59.4%)	6.9 A (55.2%)
	FR2	23 A (74.1%)	23 A (74.1%)	23 A (74.1%)	23 A (74.1%)	23 A (74.1%)	23 A (74.1%)	23 A (74.1%)	22 A (70.9%)	21 A (67.7%)	20 A (64.5%)	19 A (61.2%)	17 A (54.8%)
	FR3	50 A (81.9%)	50 A (81.9%)	50 A (81.9%)	50 A (81.9%)	50 A (81.9%)	50 A (81.9%)	50 A (81.9%)	49 A (80.3%)	48 A (78.6%)	47 A (77%)	45.6 A (74.8%)	43 A (70.4%)
	FR4	85 A (74.5%)	85 A (74.5%)	85 A (74.5%)	85 A (74.5%)	83.7 A (73.4%)	80.4 A (70.5%)	77.2 A (67.7%)	74 A (64.9%)	71 A (62.2%)	68 A (59.6%)	65 A (57%)	—
	FR5	135 A (63.9%)	135 A (63.9%)	135 A (63.9%)	135 A (63.9%)	131.9 A (62.5%)	124.2 A (58.9%)	116.6 A (55.2%)	109 A (51.6%)	101.1 A (47.9%)	93.3 A (44.2%)	85.5 A (40.5%)	—
	FR6	248 A (79.5%)	233 A (74.7%)	218 A (69.9%)	—	203 A (65.1%)	188 A (60.3%)	173 A (55.4%)	158 A (50.6%)	143 A (45.8%)	128 A (41%)	113 A (36.2%)	—

**Table 50. 230 V temperature deratings (CT)**

Shading indicates default switching frequency for each frame size.

Constant torque (CT) /high overload (I <sub>H</sub> )	Frame size	Maximum rated current (A), percentage of rated current											
		Switching frequency											
		1 kHz	2 kHz	3 kHz	3.6 kHz	4 kHz	5 kHz	6 kHz	7 kHz	8 kHz	9 kHz	10 kHz	12 kHz
40 °C	FR0	6.6 A (100%)	6.6 A (100%)	6.6 A (100%)	6.6 A (100%)	6.6 A (100%)	6.6 A (100%)	6.6 A (100%)	6.6 A (100%)	6.6 A (100%)	6.6 A (100%)	6.6 A (100%)	6.6 A (100%)
	FR1	11 A (100%)	11 A (100%)	11 A (100%)	11 A (100%)	11 A (100%)	11 A (100%)	11 A (100%)	11 A (100%)	11 A (100%)	11 A (100%)	10.7 A (97.2%)	10.1 A (91.8%)
	FR2	25 A (100%)	25 A (100%)	25 A (100%)	25 A (100%)	25 A (100%)	25 A (100%)	25 A (100%)	25 A (100%)	25 A (100%)	25 A (100%)	25 A (100%)	25 A (100%)
	FR3	48 A (100%)	48 A (100%)	48 A (100%)	48 A (100%)	48 A (100%)	48 A (100%)	48 A (100%)	48 A (100%)	48 A (100%)	48 A (100%)	48 A (100%)	48 A (100%)
	FR4	87 A (100%)	87 A (100%)	87 A (100%)	87 A (100%)	87 A (100%)	87 A (100%)	87 A (100%)	87 A (100%)	83.6 A (96.1%)	80.3 A (92.3%)	77 A (88.5%)	—
	FR5	170 A (100%)	170 A (100%)	170 A (100%)	170 A (100%)	170 A (100%)	170 A (100%)	170 A (100%)	170 A (100%)	163.3 A (96%)	156.6 A (92.1%)	150 A (88.2%)	—
	FR6	248 A (100%)	248 A (100%)	248 A (100%)	—	248 A (100%)	248 A (100%)	248 A (100%)	238 A (95.9%)	228 A (91.9%)	218 A (87.9%)	208 A (83.8%)	—
50 °C	FR0	6.6 A (100%)	6.6 A (100%)	6.6 A (100%)	6.6 A (100%)	6.6 A (100%)	6.6 A (100%)	6.6 A (100%)	6.6 A (100%)	6.6 A (100%)	6.6 A (100%)	6.6 A (100%)	6.6 A (100%)
	FR1	11 A (100%)	11 A (100%)	11 A (100%)	11 A (100%)	11 A (100%)	10.7 A (97.7%)	10.5 A (95.4%)	10.1 A (91.8%)	9.7 A (88.1%)	9.3 A (84.5%)	8.9 A (80.9%)	8.1 A (73.6%)
	FR2	25 A (100%)	25 A (100%)	25 A (100%)	25 A (100%)	25 A (100%)	25 A (100%)	25 A (100%)	24.5 A (98%)	24 A (96%)	23.5 A (94%)	23 A (92%)	22 A (88%)
	FR3	48 A (100%)	48 A (100%)	48 A (100%)	48 A (100%)	48 A (100%)	48 A (100%)	48 A (100%)	48 A (100%)	48 A (100%)	48 A (100%)	48 A (100%)	48 A (100%)
	FR4	87 A (100%)	87 A (100%)	87 A (100%)	87 A (100%)	85.8 A (98.6%)	82.8 A (95.2%)	79.9 A (91.8%)	77 A (88.5%)	73.6 A (84.6%)	70.3 A (80.8%)	67 A (77%)	—
	FR5	170 A (100%)	170 A (100%)	170 A (100%)	170 A (100%)	166.1 A (97.7%)	156.4 A (92%)	146.7 A (86.2%)	137 A (80.5%)	126.6 A (74.5%)	116.3 A (68.4%)	106 A (62.3%)	—
	FR6	248 A (100%)	248 A (100%)	248 A (100%)	—	236 A (95.2%)	224 A (90.2%)	212 A (85.5%)	200 A (80.6%)	188 A (75.8%)	176 A (71%)	164 A (66.1%)	—
60 °C	FR0	6.6 A (100%)	6.6 A (100%)	6.6 A (100%)	6.6 A (100%)	6.6 A (100%)	6.6 A (100%)	6.6 A (100%)	6.6 A (100%)	6.6 A (100%)	6.6 A (100%)	6.6 A (100%)	6.6 A (100%)
	FR1	9.2 A (83.6%)	9.2 A (83.6%)	9.2 A (83.6%)	9.2 A (83.6%)	9.2 A (83.6%)	8.9 A (80.9%)	8.6 A (78.1%)	8.3 A (75.4%)	8 A (72.7%)	7.7 A (70%)	7.4 A (67.2%)	6.8 A (61.8%)
	FR2	23 A (92%)	23 A (92%)	23 A (92%)	23 A (92%)	23 A (92%)	23 A (92%)	23 A (92%)	22 A (88%)	21 A (84%)	20 A (80%)	19 A (76%)	17 A (68%)
	FR3	44 A (91.6%)	44 A (91.6%)	44 A (91.6%)	44 A (91.6%)	44 A (91.6%)	43.3 A (90.2%)	42.8 A (89.3%)	42.4 A (88.4%)	42 A (87.5%)	41.3 A (86.1%)	40.8 A (85.1%)	40 A (83.3%)
	FR4	73 A (83.9%)	73 A (83.9%)	73 A (83.9%)	73 A (83.9%)	71.7 A (82.4%)	68.4 A (78.7%)	65.2 A (74.9%)	62 A (71.2%)	58.6 A (67.4%)	55.3 A (63.6%)	52 A (59.7%)	—
	FR5	135 A (79.4%)	135 A (79.4%)	135 A (79.4%)	135 A (79.4%)	131.9 A (77.6%)	124.2 A (73.1%)	116.6 A (68.6%)	109 A (64.1%)	101.1 A (59.5%)	93.3 A (54.9%)	85.5 A (50.2%)	—
	FR6	248 A (100%)	233 A (94%)	218 A (87.9%)	—	203 A (81.9%)	188 A (75.8%)	173 A (69.8%)	158 A (63.7%)	143 A (57.7%)	128 A (51.6%)	113 A (45.6%)	—

## Appendix B—Installation guidelines

**Table 51. 480 V temperature deratings (VT)**

Shading indicates default switching frequency for each frame size.

Variable torque (VT)/ low overload (I <sub>L</sub> )	Frame size	Maximum rated current (A), percentage of rated current											
		Switching frequency											
		1 kHz	2 kHz	3 kHz	3.6 kHz	4 kHz	5 kHz	6 kHz	7 kHz	8 kHz	9 kHz	10 kHz	12 kHz
Temperature													
40 °C	FR0	7.6 A (100%)	7.6 A (100%)	7.6 A (100%)	7.6 A (100%)	7.6 A (100%)	7.6 A (100%)	7.6 A (100%)	7.4 A (97.2%)	7.2 A (94.3%)	7 A (91.5%)	6.7 A (88.6%)	6.3 A (82.9%)
	FR1	12 A (100%)	12 A (100%)	12 A (100%)	12 A (100%)	12 A (100%)	12 A (100%)	12 A (100%)	11.2 A (93.7%)	10.5 A (87.5%)	9.7 A (81.2%)	9 A (75%)	7.5 A (62.5%)
	FR2	31 A (100%)	31 A (100%)	31 A (100%)	31 A (100%)	31 A (100%)	31 A (100%)	31 A (100%)	29.5 A (95.1%)	28 A (90.3%)	26.5 A (85.4%)	25 A (80.6%)	22 A (70.9%)
	FR3	61 A (100%)	61 A (100%)	61 A (100%)	61 A (100%)	61 A (100%)	61 A (100%)	61 A (100%)	58.2 A (95.4%)	55.5 A (90.9%)	52.7 A (86.4%)	50 A (81.9%)	44.5 A (72.9%)
	FR4	105 A (100%)	105 A (100%)	105 A (100%)	105 A (100%)	102.7 A (97.8%)	97.1 A (92.5%)	91.5 A (87.1%)	85.8 A (81.7%)	80.2 A (76.4%)	74.6 A (71%)	69 A (65.7%)	—
	FR5	205 A (100%)	205 A (100%)	205 A (100%)	205 A (100%)	199.6 A (97.3%)	186.3 A (90.8%)	173 A (84.3%)	159.5 A (77.8%)	146 A (71.2%)	132.5 A (64.6%)	119 A (58%)	—
	FR6	310 A (100%)	310 A (100%)	310 A (100%)	—	290 A (93.5%)	270 (87.1%)	250 A (80.6%)	230 A (74.2%)	210 A (67.7%)	190 A (61.3%)	170 A (54.8%)	—
50 °C	FR0	7.6 A (100%)	7.6 A (100%)	7.6 A (100%)	7.6 A (100%)	7.6 A (100%)	7.6 A (100%)	7.6 A (100%)	7.2 A (94.3%)	6.7 A (88.6%)	6.3 A (82.9%)	5.9 A (77.2%)	5 A (65.8%)
	FR1	9 A (75%)	9 A (75%)	9 A (75%)	9 A (75%)	9 A (75%)	9 A (75%)	9 A (75%)	8.5 A (70.8%)	8 A (66.6%)	7.5 A (62.5%)	7 A (58.3%)	6 A (50%)
	FR2	25 A (80.6%)	25 A (80.6%)	25 A (80.6%)	25 A (80.6%)	25 A (80.6%)	25 A (80.6%)	25 A (80.6%)	24 A (77.4%)	23 A (74.1%)	22 A (70.9%)	21 A (67.7%)	19 A (61.2%)
	FR3	51.8 A (84.9%)	51.8 A (84.9%)	51.8 A (84.9%)	51.8 A (84.9%)	51.8 A (84.9%)	51.8 A (84.9%)	51.8 A (84.9%)	49.4 A (81%)	47.1 A (77.2%)	44.7 A (73.3%)	42.4 A (69.5%)	37.7 A (61.8%)
	FR4	92 A (87.6%)	92 A (87.6%)	92 A (87.6%)	92 A (87.6%)	89.9 A (85.6%)	84.7 A (80.7%)	79.6 A (75.8%)	74.4 A (70.9%)	69.3 A (66%)	64.1 A (61.1%)	59 A (56.1%)	—
	FR5	170 A (82.9%)	170 A (82.9%)	170 A (82.9%)	170 A (82.9%)	165 A (80.4%)	152.5 A (74.3%)	140 A (68.2%)	127.5 A (62.1%)	115 A (56%)	102.5 A (50%)	90 A (43.9%)	—
	FR6	295 A (95.2%)	275 A (88.7%)	255 A (82.2%)	—	235 A (75.8%)	215 A (69.3%)	195 A (62.9%)	175 A (56.4%)	155 A (50%)	135 A (43.5%)	115 A (37%)	—
60 °C	FR0	7.6 A (100%)	7.6 A (100%)	7.6 A (100%)	7.6 A (100%)	7.6 A (100%)	7.6 A (100%)	7.6 A (100%)	7.1 A (93.4%)	6.6 A (86.8%)	6.1 A (80.3%)	5.6 A (73.7%)	4.6 A (60.5%)
	FR1	7 A (58.3%)	7 A (58.3%)	7 A (58.3%)	7 A (58.3%)	7 A (58.3%)	7 A (58.3%)	7 A (58.3%)	6.5 A (54.1%)	6 A (50%)	5.5 A (45.8%)	5 A (41.6%)	4 A (33.3%)
	FR2	21 A (67.7%)	21 A (67.7%)	21 A (67.7%)	21 A (67.7%)	21 A (67.7%)	21 A (67.7%)	21 A (67.7%)	20 A (64.5%)	19 A (61.2%)	18 A (58%)	17 A (54.8%)	15 A (48.3%)
	FR3	43.5 A (71.3%)	43.5 A (71.3%)	43.5 A (71.3%)	43.5 A (71.3%)	43.5 A (71.3%)	43.5 A (71.3%)	43.5 A (71.3%)	41.6 A (68.2%)	39.8 A (65.2%)	37 A (60.7%)	34.3 A (56.2%)	29.7 A (48.6%)
	FR4	76 A (72.3%)	76 A (72.3%)	76 A (72.3%)	76 A (72.3%)	74.1 A (70.5%)	69.4 A (66.1%)	64.7 A (61.6%)	60 A (57.2%)	55.3 A (52.7%)	50.6 A (48.2%)	46 A (43.8%)	—
	FR5	140 A (68.2%)	140 A (68.2%)	140 A (68.2%)	140 A (68.2%)	135.6 A (66.1%)	124.6 A (60.8%)	113.7 A (55.4%)	102.8 A (50.1%)	91.8 A (44.8%)	80.9 A (39.4%)	70 A (34.1%)	—
	FR6	250 A (80.6%)	230 A (74.2%)	210 A (67.7%)	—	190 A (61.3%)	170 A (54.8%)	150 A (48.4%)	130 A (41.9%)	110 A (35.5%)	90 A (29%)	70 A (22.6%)	—

**Table 52. 480 V temperature deratings (CT)**

Shading indicates default switching frequency for each frame size.

Constant torque (CT)/ high overload (I <sub>h</sub> )	Maximum rated current (A), percentage of rated current												
	Frame size	Switching frequency											
		1 kHz	2 kHz	3 kHz	3.6 kHz	4 kHz	5 kHz	6 kHz	7 kHz	8 kHz	9 kHz	10 kHz	12 kHz
40 °C	FR0	5.6 A (100%)	5.6 A (100%)	5.6 A (100%)	5.6 A (100%)	5.6 A (100%)	5.6 A (100%)	5.6 A (100%)	5.6 A (100%)	5.6 A (100%)	5.6 A (100%)	5.6 A (100%)	5.6 A (100%)
	FR1	7.6 A (100%)	7.6 A (100%)	7.6 A (100%)	7.6 A (100%)	7.6 A (100%)	7.6 A (100%)	7.6 A (100%)	7.3 A (96%)	7 A (92.1%)	6.7 A (88.1%)	6.4 A (84.2%)	5.8 A (76.3%)
	FR2	23 A (100%)	23 A (100%)	23 A (100%)	23 A (100%)	23 A (100%)	23 A (100%)	23 A (100%)	23 A (100%)	23 A (100%)	23 A (100%)	22 A (95.6%)	20 A (86.9%)
	FR3	46 A (100%)	46 A (100%)	46 A (100%)	46 A (100%)	46 A (100%)	46 A (100%)	46 A (100%)	46 A (100%)	46 A (100%)	44 A (95.6%)	42 A (91.3%)	38 A (82.6%)
	FR4	87 A (100%)	87 A (100%)	87 A (100%)	87 A (100%)	87 A (100%)	87 A (100%)	87 A (100%)	82.5 A (94.8%)	78 A (89.6%)	73.5 A (84.4%)	69 A (79.3%)	—
	FR5	170 A (100%)	170 A (100%)	170 A (100%)	170 A (100%)	170 A (100%)	170 A (100%)	170 A (100%)	157.5 A (92.6%)	145 A (85.2%)	132.5 A (77.9%)	120 A (70.5%)	—
	FR6	245 A (100%)	245 A (100%)	245 A (100%)	—	245 A (100%)	245 A (100%)	230 A (93.8%)	215 A (87.7%)	200 A (81.6%)	185 A (75.5%)	170 A (69.4%)	—
50 °C	FR0	5.6 A (100%)	5.6 A (100%)	5.6 A (100%)	5.6 A (100%)	5.6 A (100%)	5.6 A (100%)	5.6 A (100%)	5.6 A (100%)	5.6 A (100%)	5.6 A (100%)	5.6 A (100%)	5 A (89.3%)
	FR1	7.6 A (100%)	7.6 A (100%)	7.6 A (100%)	7.6 A (100%)	7.6 A (100%)	7.2 A (95.7%)	6.9 A (91.4%)	6.6 A (87.1%)	6.2 A (82.8%)	5.9 A (78.5%)	5.6 A (74.2%)	5 A (65.7%)
	FR2	23 A (100%)	23 A (100%)	23 A (100%)	23 A (100%)	23 A (100%)	22 A (95.6%)	21 A (91.3%)	20 A (86.9%)	19 A (82.6%)	18 A (78.2%)	17 A (73.9%)	15 A (65.2%)
	FR3	46 A (100%)	46 A (100%)	46 A (100%)	46 A (100%)	46 A (100%)	43.5 A (94.5%)	41 A (89.1%)	38.5 A (83.6%)	36 A (78.2%)	33.5 A (72.8%)	31 A (67.3%)	26 A (56.5%)
	FR4	87 A (100%)	87 A (100%)	87 A (100%)	87 A (100%)	85.2 A (97.9%)	80.8 A (92.9%)	76.5 A (87.9%)	72.1 A (82.9%)	67.7 A (77.8%)	63.3 A (72.8%)	59 A (67.8%)	—
	FR5	170 A (100%)	170 A (100%)	170 A (100%)	170 A (100%)	165 A (97%)	152.5 A (89.7%)	140 A (82.3%)	127.5 A (75%)	115 A (67.6%)	102.5 A (60.2%)	90 A (52.9%)	—
	FR6	245 A (100%)	245 A (100%)	245 A (100%)	—	227 A (92.6%)	209 A (85.3%)	191 A (77.9%)	173 A (70.6%)	155 A (63.2%)	137 A (55.9%)	119 A (48.6%)	—
60 °C	FR0	5.6 A (100%)	5.6 A (100%)	5.6 A (100%)	5.6 A (100%)	5.6 A (100%)	5.6 A (100%)	5.6 A (100%)	5.6 A (100%)	5.6 A (100%)	5.6 A (100%)	5.6 A (100%)	4.6 A (82.1%)
	FR1	7 A (92.1%)	7 A (92.1%)	7 A (92.1%)	7 A (92.1%)	7 A (92.1%)	6.6 A (87.1%)	6.2 A (82.2%)	5.8 A (77.2%)	5.4 A (72.3%)	5.1 A (67.3%)	4.7 A (62.4%)	4 A (52.6%)
	FR2	18 A (78.2%)	18 A (78.2%)	18 A (78.2%)	18 A (78.2%)	18 A (78.2%)	17 A (73.9%)	16 A (69.5%)	15 A (65.2%)	14 A (60.8%)	13 A (56.5%)	12 A (52.1%)	10 A (43.4%)
	FR3	37 A (80.4%)	37 A (80.4%)	37 A (80.4%)	37 A (80.4%)	37 A (80.4%)	35 A (76%)	33 A (71.7%)	31 A (67.3%)	29 A (63%)	27 A (58.6%)	25 A (54.3%)	21 A (45.6%)
	FR4	76 A (87.3%)	76 A (87.3%)	76 A (87.3%)	76 A (87.3%)	74.1 A (85.2%)	69.4 A (79.8%)	64.7 A (74.4%)	60 A (69%)	55.3 A (63.6%)	50.6 A (58.2%)	46 A (52.8%)	—
	FR5	140 A (82.3%)	140 A (82.3%)	140 A (82.3%)	140 A (82.3%)	135.6 A (79.7%)	124.6 A (73.3%)	113.7 A (66.9%)	102.8 A (60.4%)	91.8 A (54%)	80.9 A (47.6%)	70 A (41.1%)	—
	FR6	240 A (97.9%)	222 A (90.6%)	204 A (83.3%)	—	186 A (75.9%)	168 A (68.6%)	150 A (61.2%)	132 A (53.9%)	114 A (46.5%)	96 A (39.2%)	78 A (31.8%)	—

## Appendix B—Installation guidelines

**Table 53. 600 V temperature deratings (VT)**

Shading indicates default switching frequency for each frame size.

Variable torque (VT)/ low overload (I <sub>L</sub> )	Frame size	Maximum rated current (A), percentage of rated current						
		Switching frequency						
		1 kHz	1.5 kHz	2 kHz	3 kHz	4 kHz	5 kHz	6 kHz
40 °C	FR1	10 A (100%)	10 A (100%)	10 A (100%)	10 A (100%)	8 A (80%)	6 A (60%)	4 A (40%)
	FR2	22 A (100%)	22 A (100%)	22 A (100%)	22 A (100%)	19.5 A (88.6%)	16.9 A (77.2%)	14.5 A (65.9%)
	FR3	41 A (100%)	41 A (100%)	41 A (100%)	41 A (100%)	37.9 A (92.6%)	35 A (85.3%)	32 A (78%)
	FR4	80 A (100%)	80 A (100%)	80 A (100%)	80 A (100%)	70 A (87.5%)	60 A (75%)	50 A (62.5%)
	FR5	144 A (100%)	144 A (100%)	144 A (100%)	123.9 A (86.1%)	103.9 A (72.2%)	83.9 A (58.3%)	63.9 A (44.4%)
	FR6	250 (100%)	250 (100%)	234 A (93.6%)	202 A (80.8%)	170 A (68%)	138 A (55.2%)	106 (42.4%)
50 °C	FR1	8 A (80%)	8 A (80%)	8 A (80%)	8 A (80%)	6.5 A (65%)	5 A (50%)	3.5 A (35%)
	FR2	18 A (81.8%)	18 A (81.8%)	18 A (81.8%)	18 A (81.8%)	16 A (72.7%)	14 A (63.6%)	12 A (54.5%)
	FR3	34 A (82.9%)	34 A (82.9%)	34 A (82.9%)	34 A (82.9%)	31 A (75.6%)	27.9 A (68.2%)	25 A (60.9%)
	FR4	70 A (87.5%)	70 A (87.5%)	70 A (87.5%)	70 A (87.5%)	59.6 A (74.5%)	49.2 A (61.5%)	38.8 A (48.5%)
	FR5	125 A (86.8%)	125 A (86.8%)	125 A (86.8%)	108 A (75%)	90.9 A (63.1%)	74 A (51.3%)	56.9 A (39.5%)
	FR6	208 (83.2%)	208 (83.2%)	192 A (76.8%)	160 A (64%)	128 A (51.2%)	96 A (38.4%)	64 (25.6%)
60 °C	FR1	5.3 A (53%)	5.3 A (53%)	5.3 A (53%)	5.3 A (53%)	4.4 A (44%)	3.5 A (35%)	2.6 A (26%)
	FR2	13 A (59.1%)	13 A (59.1%)	13 A (59.1%)	13 A (59.1%)	11 A (50%)	9 A (40.9%)	7 A (31.8%)
	FR3	27 A (65.9%)	27 A (65.9%)	27 A (65.9%)	27 A (65.9%)	23 A (56.1%)	18.9 A (46.3%)	15 A (36.5%)
	FR4	58 A (72.5%)	58 A (72.5%)	58 A (72.5%)	58 A (72.5%)	49.6 A (62%)	41.2 A (51.5%)	32.8 A (41%)
	FR5	105 A (72.9%)	105 A (72.9%)	105 A (72.9%)	90 A (62.5%)	75 A (52%)	60 A (41.6%)	45 A (31.2%)
	FR6	203 (81.2%)	188 (75.2%)	173 A (69.2%)	143 A (57.2%)	113 A (45.2%)	83 A (33.2%)	53 (21.2%)



**Table 54. 600 V temperature deratings (CT)**

Shading indicates default switching frequency for each frame size.

Constant torque (CT)/ high overload ( $I_H$ )	Frame Size	Maximum rated current (A), percentage of rated current						
		Switching frequency						
		1 kHz	1.5 kHz	2.5 kHz	3.5 kHz	4.5 kHz	5.5 kHz	6 kHz
40 °C	FR1	7.5 A (100%)	7.5 A (100%)	7.5 A (100%)	7.5 A (100%)	7.5 A (100%)	6 A (80%)	4.5 A (60%)
	FR2	18 A (100%)	18 A (100%)	18 A (100%)	18 A (100%)	18 A (100%)	16.2 A (90%)	14.5 A (80.5%)
	FR3	34 A (100%)	34 A (100%)	34 A (100%)	34 A (100%)	34 A (100%)	34 A (100%)	32 A (94.1%)
	FR4	62 A (100%)	62 A (100%)	62 A (100%)	62 A (100%)	62 A (100%)	62 A (100%)	50 A (80.6%)
	FR5	125 A (100%)	125 A (100%)	125 A (100%)	124 A (99.2%)	104 A (83.2%)	84 A (67.2%)	64 A (51.2%)
	FR6	208 (100%)	208 (100%)	208 (100%)	181 (87%)	154 (74%)	127 (61.1%)	113.5 (54.6%)
50 °C	FR1	7.5 A (100%)	7.5 A (100%)	7.5 A (100%)	7.5 A (100%)	6 A (80%)	4.5 A (60%)	3 A (40%)
	FR2	18 A (100%)	18 A (100%)	18 A (100%)	18 A (100%)	16 A (88.8%)	14 A (77.7%)	12 A (66.6%)
	FR3	34 A (100%)	34 A (100%)	34 A (100%)	34 A (100%)	31 A (91.1%)	28 A (82.3%)	25 A (73.5%)
	FR4	62 A (100%)	62 A (100%)	62 A (100%)	62 A (100%)	52.7 A (85%)	43.4 A (70%)	34.1 A (55%)
	FR5	125 A (100%)	125 A (100%)	125 A (100%)	108 A (86.4%)	91 A (72.8%)	74 A (59.2%)	57 A (45.6%)
	FR6	208 (100%)	208 (100%)	176 (84.6%)	144 (69.2%)	112 (53.8%)	80 (38.5%)	64 (30.8%)
60 °C	FR1	5.3 A (70.6%)	5.3 A (70.6%)	5.3 A (70.6%)	5.3 A (70.6%)	4.4 A (58.6%)	3.5 A (46.6%)	2.6 A (34.6%)
	FR2	13 A (72.2%)	13 A (72.2%)	13 A (72.2%)	13 A (72.2%)	11 A (61.1%)	9 A (50%)	7 A (38.8%)
	FR3	27 A (79.4%)	27 A (79.4%)	27 A (79.4%)	27 A (79.4%)	23 A (67.6%)	19 A (55.8%)	15 A (44.1%)
	FR4	50.8 A (82%)	50.8 A (82%)	50.8 A (82%)	50.8 A (82%)	44 A (71%)	37.2 A (60%)	30.3 A (49%)
	FR5	105 A (84%)	105 A (84%)	105 A (84%)	90 A (72%)	75 A (60%)	60 A (48%)	45 A (36%)
	FR6	203 (97.6%)	188 (90.4%)	158 (76%)	128 (61.5%)	98 (47.1%)	68 (32.7%)	53 (25.5%)

## Heat loss data

Table 55. 230 V heat loss data

Frame size	CT Amp Suffix	VT Amp Suffix	230 V, 60 Hz	
			VT/I <sub>L</sub> (110%) Pv (W)	CT/I <sub>H</sub> (150%) Pv (W)
0	3D7	4D8	53	43
	4D8	6D6	73	50
	6D6	7D8	88	70
1	3D7	4D8	63	46
	4D8	6D6	78	60
	6D6	7D8	89	77
	7D8	011	108	86
	011	012	129	103
2	012	017	163	111
	017	025	229	165
	025	031	315	214
3	031	048	445	239
	048	061	602	425
4	061	075	689	524
	075	088	830	689
	088	114	1167	830
5	114	143	1077	810
	143	170	1336	1077
	170	211	1724	1336
6	211	261	2191	1698
	248	312	2736	2053

Table 56. 400 V heat loss data

Frame size	CT Amp Suffix	VT Amp Suffix	400 V, 50 Hz		460 V, 60 Hz	
			VT/I <sub>L</sub> (110%) Pv (W)	CT/I <sub>H</sub> (150%) Pv (W)	VT/I <sub>L</sub> (110%) Pv (W)	CT/I <sub>H</sub> (150%) Pv (W)
0	2D2	3D3	49	33	58	37
	3D3	4D3	61	46	73	53
	4D3	5D6	82	58	99	66
	5D6	7D6	115	77	139	90
1	2D2	3D3	59	49	56	48
	3D3	4D3	73	60	71	59
	4D3	5D6	86	75	83	71
	5D6	7D6	105	83	109	82
	7D6	9D0	130	103	112	99
	9D0	012	167	129	156	104
2	012	016	191	121	189	113
	016	023	293	168	242	169
	023	031	421	268	365	228
3	031	038	471	361	433	349
	038	046	575	433	499	394
	046	061	818	541	671	451
4	061	072	758	631	706	539
	072	087	914	758	851	706
	087	105	1217	914	1187	852
5	105	140	1289	918	1112	901
	140	170	1594	1289	1399	1112
	170	205	2024	1594	1759	1399
6	205	261	2620	1960	2340	1750
	245	310	3280	2420	3120	2330

**Table 57. 600 V heat loss data**

Frame size	CT Amp suffix	VT Amp suffix	600 V, 60 Hz	
			VT/I <sub>L</sub> (110%) P <sub>v</sub> (W)	CT/I <sub>n</sub> (150%) P <sub>v</sub> (W)
FR1	3D3	4D5	94	70
	4D5	7D5	118	92
	7D5	010	177	147
FR2	010	013	221	153
	013	018	303	221
	018	022	391	303
FR3	022	027	451	350
	027	034	512	363
	034	041	633	548
FR4	041	052	738	586
	052	062	884	743
	062	080	1187	894
FR5	080	100	1149	842
	100	125	1390	1055
	125	144	1627	1304
FR6	144	208	2502	1688
	208	250	3165	2506

**Table 58. 230 V idle heat loss FR0~FR6**

Frame size	Heat loss (W)					
	IP54 version		IP21 version		IP20 version	
	Fans start	Fans stop	Fans start	Fans stop	Fans start	Fans stop
FR0	—	—	—	—	11	8.45
FR1	17.56	15.33	17.56	15.33	—	—
FR2	30.46	18.97	28.23	16.62	—	—
FR3	46.16	18.15	46.16	18.15	—	—
FR4	74.28	17.1	74.28	17.1	—	—
FR5	87.17	19.32	87.17	19.32	—	—
FR6	299.29	59.17	299.29	59.17	—	—

## Brake resistor sizing

**Table 61. Brake resistor sizing data**

Frame size	230 V		460 V		600 V	
	Brake chopper nominal current at 80 °C (A)	Minimum resistance (Ohm)	Brake chopper nominal current at 80 °C (A)	Minimum resistance (Ohm)	Brake chopper nominal current at 80 °C (A)	Minimum resistance (Ohm)
FR0	20	30	18	63	—	—
FR1	30.0	30.0	25.0	63.0	26.0	100.0
FR2	78.0	20.0	78.0	42.0	41.0	30.0
FR3	100.0	10.0	100.0	14.0	100.0	18.0
FR4	200.0	3.3	200.0	6.5	200.0	9.0
FR5	400.0	1.4	450.0	3.3	400.0	7.0
FR6	600	1.4	600	3.3	450	2.5

**Table 59. 480 V idle heat loss FR0~FR6**

Frame size	Heat loss (W)					
	IP54 version		IP21 version		IP20 version	
	Fans start	Fans stop	Fans start	Fans stop	Fans start	Fans stop
FR0	—	—	—	—	13.9	11.4
FR1	20.49	17.33	17.56	15.1	—	—
FR2	29.76	19.5	24.89	15.75	—	—
FR3	46.63	24.12	46.63	24.12	—	—
FR4	79.67	24.42	79.67	24.42	—	—
FR5	102.83	30.74	102.83	30.74	—	—
FR6	305.9	62.45	305.9	62.45	—	—

**Table 60. 575 V idle heat loss FR1~FR6**

Frame size	Heat loss (W)			
	IP54 version		IP21 version	
	Fans start	Fans stop	Fans start	Fans stop
FR1	22.2	18.96	20.97	18.08
FR2	33.56	23.19	32.09	20.96
FR3	52.96	26.41	52.96	26.41
FR4	84.42	24.65	84.42	24.65
FR5	97.37	27.23	97.37	27.23
FR6	317.63	84.3	317.63	84.3

## Efficiency ratings

**Table 62. 230 V FR0-Xhp efficiency rating**

	25%Torque						50%Torque						100%Torque					
	Pin (kW)	Pout (kW)	Ploss (kW)	Ploss (%)	Power factor output	Efficiency (%)	Pin (kW)	Pout (kW)	Ploss (kW)	Ploss (%)	Power factor output	Efficiency (%)	Pin (kW)	Pout (kW)	Ploss (kW)	Ploss (%)	Power factor output	Efficiency (%)
10%Speed	0.15007	0.10759	0.04248	28.31%	0.40878	71.69%	0.20843	0.17042	0.03801	18.24%	0.5486	81.76%	0.34187	0.2867	0.05517	16.14%	0.6629	83.86%
50%Speed	0.39832	0.35507	0.04325	10.86%	0.298	89.14%	0.6099	0.56306	0.04684	7.68%	0.451	92.32%	1.07267	1.00629	0.06638	6.19%	0.6678	93.81%
90%Speed	0.61219	0.56622	0.04597	7.51%	0.259	92.49%	0.96485	0.91007	0.05478	5.68%	0.397	94.32%	1.70079	1.63519	0.0656	3.86%	0.60754	96.14%
100%Speed	0.6592	0.6094	0.0498	7.55%	0.25	92.45%	1.0525	0.99872	0.05378	5.11%	0.391	94.89%	1.8725	1.80729	0.06521	3.48%	0.602	96.52%

**Table 63. 230 V FR1-4hp efficiency rating**

	25%Torque						50%Torque						100%Torque					
	Pin (kW)	Pout (kW)	Ploss (kW)	Ploss (%)	Power factor output	Efficiency (%)	Pin (kW)	Pout (kW)	Ploss (kW)	Ploss (%)	Power factor output	Efficiency (%)	Pin (kW)	Pout (kW)	Ploss (kW)	Ploss (%)	Power factor output	Efficiency (%)
10%Speed	0.189	0.136	0.053	28.04%	0.469	71.89%	0.277	0.216	0.061	22.02%	0.603	77.89%	0.514	0.43	0.084	16.34%	0.74	83.65%
50%Speed	0.677	0.616	0.061	9.01%	0.39	90.98%	1.078	1.001	0.077	7.14%	0.568	92.01%	2.029	1.93	0.099	4.88%	0.773	95.18%
90%Speed	1.169	1.105	0.064	5.47%	0.386	94.54%	1.994	1.913	0.081	4.06%	0.581	95.95%	3.53	3.412	0.118	3.34%	0.762	96.61%
100%Speed	1.269	1.201	0.068	5.36%	0.379	94.68%	2.119	2.034	0.085	4.01%	0.564	96.02%	3.91	3.786	0.124	3.17%	0.761	96.72%

**Note:** All 10% speed is taken at 5Hz.

**Table 64. 230 V FR2-10hp efficiency rating**

	25%Torque						50%Torque						100%Torque					
	Pin (kW)	Pout (kW)	Ploss (kW)	Ploss (%)	Power factor output	Efficiency (%)	Pin (kW)	Pout (kW)	Ploss (kW)	Ploss (%)	Power factor output	Efficiency (%)	Pin (kW)	Pout (kW)	Ploss (kW)	Ploss (%)	Power factor output	Efficiency (%)
10%Speed	0.387	0.304	0.083	21.45%	0.607	78.42%	0.703	0.588	0.115	16.36%	0.74	83.68%	1.699	1.465	0.234	13.77%	0.82	86.26%
50%Speed	1.488	1.376	0.112	7.53%	0.561	92.46%	2.77	2.659	0.111	4.01%	0.769	96.00%	5.637	5.391	0.246	4.36%	0.866	95.64%
90%Speed	2.635	2.535	0.1	3.80%	0.553	96.21%	4.776	4.642	0.134	2.81%	0.76	97.19%	9.346	9.061	0.285	3.05%	0.87	96.96%
100%Speed	2.847	2.746	0.101	3.55%	0.638	96.45%	5.222	5.073	0.149	2.85%	0.817	97.15%	10.556	10.225	0.331	3.14%	0.871	96.86%

**Note:** All 10% speed is taken at 5Hz.

**Table 65. 230 V FR3-20hp efficiency rating**

	25%Torque						50%Torque						100%Torque					
	Pin (kW)	Pout (kW)	Ploss (kW)	Ploss (%)	Power factor output	Efficiency (%)	Pin (kW)	Pout (kW)	Ploss (kW)	Ploss (%)	Power factor output	Efficiency (%)	Pin (kW)	Pout (kW)	Ploss (kW)	Ploss (%)	Power factor output	Efficiency (%)
10%Speed	0.732	0.589	0.143	19.54%	0.605	80.33%	1.448	1.241	0.207	14.30%	0.777	85.74%	2.085	1.798	0.287	13.76%	0.761	86.22%
50%Speed	2.62	2.46	0.16	6.11%	0.527	93.57%	5.16	4.92	0.24	4.65%	0.766	95.32%	10.54	10.06	0.48	4.55%	0.877	95.45%
90%Speed	4.656	4.464	0.192	4.12%	0.521	95.88%	8.836	8.56	0.276	3.12%	0.745	96.87%	17.55	17.001	0.549	3.13%	0.869	96.86%
100%Speed	5.224	5.031	0.193	3.69%	0.525	96.30%	9.885	9.606	0.279	2.82%	0.767	97.16%	19.544	18.936	0.608	3.11%	0.882	96.88%

**Note:** All 10% speed is taken at 5Hz.

**Table 66. 230 V FR4-40hp efficiency rating**

	230 V FR4-40hp																	
	25%Torque						50%Torque						100%Torque					
	Pin (kW)	Pout (kW)	Ploss (kW)	Ploss (%)	Power factor output	Efficiency (%)	Pin (kW)	Pout (kW)	Ploss (kW)	Ploss (%)	Power factor output	Efficiency (%)	Pin (kW)	Pout (kW)	Ploss (kW)	Ploss (%)	Power factor output	Efficiency (%)
10%Speed	1.113	0.87	0.243	21.83%	0.559	78.23%	1.996	1.67	0.326	16.33%	0.719	83.69%	3.892	3.354	0.538	13.82%	0.798	86.18%
50%Speed	4.628	4.34	0.288	6.22%	0.572	93.78%	9.195	8.772	0.423	4.60%	0.7896	95.39%	17.93	17.12	0.81	4.52%	0.867	95.48%
90%Speed	8.046	7.735	0.311	3.87%	0.565	96.13%	16.095	15.622	0.473	2.94%	0.784	97.06%	32.156	31.208	0.948	2.95%	0.872	97.05%
100%Speed	8.929	8.608	0.321	3.60%	0.562	96.41%	17.67	17.19	0.48	2.72%	0.781	97.29%	35.17	34.214	0.956	2.72%	0.877	97.28%

**Note:** All 10% speed is taken at 5Hz.

**Table 67. 230 V FR5-75hp efficiency rating**

	230 V FR5-75hp																	
	25%Torque						50%Torque						100%Torque					
	Pin (kW)	Pout (kW)	Ploss (kW)	Ploss (%)	Power factor output	Efficiency (%)	Pin (kW)	Pout (kW)	Ploss (kW)	Ploss (%)	Power factor output	Efficiency (%)	Pin (kW)	Pout (kW)	Ploss (kW)	Ploss (%)	Power factor output	Efficiency (%)
10%Speed	1.955	1.604	0.351	17.95%	0.566	82.05%	3.922	3.413	0.723	18.43%	0.87027	86.23%	8.176	7.279	0.897	10.97%	0.792	89.03%
50%Speed	8.33	7.926	0.404	4.85%	0.619	95.12%	16.407	15.783	0.624	3.80%	0.817	96.20%	33.429	32.124	1.305	3.90%	0.884	96.10%
90%Speed	14.539	14.086	0.453	3.12%	0.611	96.89%	28.707	27.989	0.718	2.50%	0.814	97.50%	57.974	56.471	1.503	2.59%	0.887	97.41%
100%Speed	16.195	15.747	0.448	2.77%	0.641	97.23%	31.865	31.131	0.734	2.30%	0.835	97.71%	64.892	63.21	1.682	2.59%	0.892	97.41%

**Note:** All 10% speed is taken at 5Hz.

**Table 68. 400 V FR0-Xhp efficiency rating**

	400 V FR0-Xhp																	
	25%Torque						50%Torque						100%Torque					
	Pin (kW)	Pout (kW)	Ploss (kW)	Ploss (%)	Power factor output	Efficiency (%)	Pin (kW)	Pout (kW)	Ploss (kW)	Ploss (%)	Power factor output	Efficiency (%)	Pin (kW)	Pout (kW)	Ploss (kW)	Ploss (%)	Power factor output	Efficiency (%)
10%Speed	0.2597	0.2043	0.0554	21.33%	0.4867	78.67%	0.3677	0.3133	0.0544	14.79%	0.5958	85.21%	0.6045	0.5176	0.0869	14.38%	0.692	85.62%
50%Speed	0.7224	0.665	0.0574	7.95%	0.383	92.05%	1.1296	1.0713	0.0583	5.16%	0.5566	94.84%	1.9884	1.906	0.0824	4.14%	0.747	95.86%
90%Speed	1.2338	1.1782	0.0556	4.51%	0.37	95.49%	1.888	1.8193	0.0687	3.64%	0.518	96.36%	3.35	3.26	0.09	2.69%	0.715	97.31%
100%Speed	1.3748	1.3103	0.0645	4.69%	0.367	95.31%	2.1335	2.0663	0.0672	3.15%	0.526	96.85%	3.7081	3.6179	0.0902	2.43%	0.717	97.57%

**Note:** All 10% speed is taken at 5Hz.

**Table 69. 400 V FR1-7.5hp efficiency rating**

	400 V FR1-7.5hp																	
	25%Torque						50%Torque						100%Torque					
	Pin (kW)	Pout (kW)	Ploss (kW)	Ploss (%)	Power factor output	Efficiency (%)	Pin (kW)	Pout (kW)	Ploss (kW)	Ploss (%)	Power factor output	Efficiency (%)	Pin (kW)	Pout (kW)	Ploss (kW)	Ploss (%)	Power factor output	Efficiency (%)
10%Speed	0.31	0.254	0.056	18.06%	0.53	81.95%	0.588	0.515	0.073	12.41%	0.696	87.58%	1.016	0.912	0.104	10.24%	0.786	89.70%
50%Speed	1.02	0.957	0.063	6.18%	0.486	93.86%	1.803	1.716	0.087	4.83%	0.695	95.28%	3.494	3.37	0.124	3.55%	0.846	96.44%
90%Speed	1.738	1.665	0.073	4.20%	0.464	95.88%	3.097	3	0.097	3.13%	0.67	96.94%	6.011	5.85	0.161	2.68%	0.829	97.39%
100%Speed	1.934	1.861	0.073	3.77%	0.481	96.25%	3.448	3.356	0.092	2.67%	0.69	97.33%	6.366	6.213	0.153	2.40%	0.83	97.60%

**Note:** All 10% speed is taken at 5Hz.

## Appendix B—Installation guidelines

**Table 70. 400 V FR2-20hp efficiency rating**

	400 V FR2-20hp																	
	25%Torque						50%Torque						100%Torque					
	Pin (kW)	Pout (kW)	Ploss (kW)	Ploss (%)	Power factor output	Efficiency (%)	Pin (kW)	Pout (kW)	Ploss (kW)	Ploss (%)	Power factor output	Efficiency (%)	Pin (kW)	Pout (kW)	Ploss (kW)	Ploss (%)	Power factor output	Efficiency (%)
10%Speed	0.7	0.572	0.128	18.29%	0.531	81.66%	1.392	1.216	0.176	12.64%	0.708	87.33%	2.414	2.156	0.258	10.69%	0.797	89.31%
50%Speed	2.363	2.227	0.136	5.76%	0.485	94.23%	4.559	4.374	0.185	4.06%	0.727	95.93%	9.182	8.833	0.349	3.80%	0.865	96.20%
90%Speed	3.971	3.819	0.152	3.83%	0.461	96.16%	7.85	7.64	0.21	2.68%	0.708	97.41%	15.482	15.096	0.386	2.49%	0.855	97.51%
100%Speed	4.535	4.386	0.149	3.29%	0.499	96.72%	8.734	8.536	0.198	2.27%	0.74	97.73%	17.303	16.904	0.399	2.31%	0.868	97.69%

**Note:** All 10% speed is taken at 5Hz.

**Table 71. 400 V FR3-40hp efficiency rating**

	400 V FR3-40hp																	
	25%Torque						50%Torque						100%Torque					
	Pin (kW)	Pout (kW)	Ploss (kW)	Ploss (%)	Power factor output	Efficiency (%)	Pin (kW)	Pout (kW)	Ploss (kW)	Ploss (%)	Power factor output	Efficiency (%)	Pin (kW)	Pout (kW)	Ploss (kW)	Ploss (%)	Power factor output	Efficiency (%)
10%Speed	1.043	0.858	0.185	17.74%	0.557	82.28%	1.886	1.65	0.236	12.51%	0.73	87.46%	3.629	3.239	0.39	10.75%	0.822	89.26%
50%Speed	4.666	4.451	0.215	4.61%	0.581	95.38%	9.156	8.834	0.322	3.52%	0.793	96.48%	18.174	17.534	0.64	3.52%	0.872	96.49%
90%Speed	8.142	7.9	0.242	2.97%	0.573	97.07%	16.09	15.716	0.374	2.32%	0.785	97.65%	31.707	30.968	0.739	2.33%	0.872	97.67%
100%Speed	8.982	8.742	0.24	2.67%	0.59	97.32%	17.734	17.359	0.375	2.11%	0.794	97.87%	34.785	34.04	0.745	2.14%	0.877	97.86%

**Note:** All 10% speed is taken at 5Hz.

**Table 72. 400 V FR4-75hp efficiency rating**

	400 V FR4-75hp																	
	25%Torque						50%Torque						100%Torque					
	Pin (kW)	Pout (kW)	Ploss (kW)	Ploss (%)	Power factor output	Efficiency (%)	Pin (kW)	Pout (kW)	Ploss (kW)	Ploss (%)	Power factor output	Efficiency (%)	Pin (kW)	Pout (kW)	Ploss (kW)	Ploss (%)	Power factor output	Efficiency (%)
10%Speed	1.735	1.426	0.309	17.81%	0.588	82.17%	3.5	3.05	0.45	12.86%	0.779	87.38%	7.026	6.227	0.799	11.37%	0.837	88.63%
50%Speed	7.711	7.34	0.371	4.81%	0.598	95.19%	15.006	14.477	0.529	3.53%	0.808	96.48%	30.273	29.232	1.041	3.44%	0.885	96.56%
90%Speed	13.543	13.153	0.39	2.88%	0.593	97.12%	26.318	25.758	0.56	2.13%	0.799	97.87%	52.871	51.724	1.147	2.17%	0.886	97.83%
100%Speed	15.019	14.632	0.387	2.58%	0.624	97.43%	29.464	28.886	0.578	1.96%	0.819	98.04%	58.669	57.491	1.178	2.01%	0.89	97.99%

**Note:** All 10% speed is taken at 5Hz.

**Table 73. 400 V FR5-150hp efficiency rating**

	400 V FR5-150hp																	
	25%Torque						50%Torque						100%Torque					
	Pin (kW)	Pout (kW)	Ploss (kW)	Ploss (%)	Power factor output	Efficiency (%)	Pin (kW)	Pout (kW)	Ploss (kW)	Ploss (%)	Power factor output	Efficiency (%)	Pin (kW)	Pout (kW)	Ploss (kW)	Ploss (%)	Power factor output	Efficiency (%)
10%Speed	2.833	2.382	0.451	15.92%	0.689	84.00%	5.823	5.13	0.693	11.90%	0.817	88.10%	12.051	10.758	1.293	10.73%	0.852	89.27%
50%Speed	14.992	14.456	0.536	3.58%	0.745	96.43%	32.798	31.858	0.94	2.87%	0.899	97.13%	64.38	62.431	1.949	3.03%	0.919	96.97%
90%Speed	28.276	27.675	0.601	2.13%	0.759	97.87%	59.715	58.641	1.074	1.80%	0.902	98.20%	111.45	109.307	2.143	1.92%	0.925	98.08%
100%Speed	30.607	30.022	0.585	1.91%	0.763	98.09%	63.925	62.905	1.02	1.60%	0.904	98.41%	120.93	118.876	2.054	1.70%	0.926	98.30%

**Note:** All 10% speed is taken at 5Hz.

**Table 74. 575 V FR1-7.5hp efficiency rating**

	575 V FR1-7.5hp																		
	25%Torque						50%Torque						100%Torque						
	Pin (kW)	Pout (kW)	Ploss (kW)	Ploss (%)	Power factor output	Efficiency (%)	Pin (kW)	Pout (kW)	Ploss (kW)	Ploss (%)	Power factor output	Efficiency (%)	Pin (kW)	Pout (kW)	Ploss (kW)	Ploss (%)	Power factor output	Efficiency (%)	
10%Speed	0.29	0.222	0.068	23.45%	0.45	76.28%	0.486	0.425	0.061	12.55%	0.622	87.46%	0.91	0.817	0.093	10.22%	0.737	89.80%	
50%Speed	1.175	1.111	0.064	5.45%	0.44	94.56%	2.099	2.024	0.075	3.57%	0.644	96.43%	4.008	3.898	0.11	2.74%	0.803	97.42%	
90%Speed	2.036	1.95	0.086	4.22%	0.424	96.36%	3.619	3.542	0.077	2.13%	0.626	97.87%	6.872	6.75	0.122	1.78%	0.787	98.24%	
100%Speed	2.23	2.161	0.069	3.09%	0.457	96.83%	4.415	4.058	0.357	8.09%	0.672	97.88%	8.01	7.871	0.139	1.74%	0.816	98.25%	

**Note:** All 10% speed is taken at 5Hz.

**Table 75. 575 V FR2-20hp efficiency rating**

	575 V FR2-20hp																		
	25%Torque						50%Torque						100%Torque						
	Pin (kW)	Pout (kW)	Ploss (kW)	Ploss (%)	Power factor output	Efficiency (%)	Pin (kW)	Pout (kW)	Ploss (kW)	Ploss (%)	Power factor output	Efficiency (%)	Pin (kW)	Pout (kW)	Ploss (kW)	Ploss (%)	Power factor output	Efficiency (%)	
10%Speed	0.523	0.424	0.099	18.93%	0.586	81.06%	1.07	0.949	0.121	11.31%	0.633	88.48%	2.123	1.942	0.181	8.53%	0.754	91.47%	
50%Speed	2.906	2.791	0.115	3.96%	0.509	96.05%	4.895	4.751	0.144	2.94%	0.693	97.05%	9.638	9.401	0.237	2.46%	0.845	97.40%	
90%Speed	5.12	4.995	0.125	2.44%	0.506	97.33%	8.659	8.497	0.162	1.87%	0.686	98.13%	16.767	16.482	0.285	1.70%	0.832	98.30%	
100%Speed	5.601	5.477	0.124	2.21%	0.533	97.74%	9.51	9.35	0.16	1.68%	0.715	98.32%	18.33	18.04	0.29	1.58%	0.842	98.41%	

**Note:** All 10% speed is taken at 5Hz.

**Table 76. 575 V FR3-40hp efficiency rating**

	575 V FR3-40hp																		
	25%Torque						50%Torque						100%Torque						
	Pin (kW)	Pout (kW)	Ploss (kW)	Ploss (%)	Power factor output	Efficiency (%)	Pin (kW)	Pout (kW)	Ploss (kW)	Ploss (%)	Power factor output	Efficiency (%)	Pin (kW)	Pout (kW)	Ploss (kW)	Ploss (%)	Power factor output	Efficiency (%)	
10%Speed	1.869	1.582	0.287	15.36%	0.569	84.63%	3.331	2.964	0.367	11.02%	0.732	88.97%	6.443	5.835	0.608	9.44%	0.826	90.56%	
50%Speed	9.647	9.309	0.338	3.50%	0.566	96.50%	18.148	17.68	0.468	2.58%	0.777	97.42%	33.857	33.074	0.783	2.31%	0.87	97.69%	
90%Speed	16.319	15.945	0.374	2.29%	0.551	97.71%	30.83	30.33	0.5	1.62%	0.759	98.40%	60.187	59.266	0.921	1.53%	0.866	98.47%	
100%Speed	17.841	17.467	0.374	2.10%	0.584	97.91%	33.966	33.441	0.525	1.55%	0.79	98.46%	65.644	64.709	0.935	1.42%	0.876	98.58%	

**Note:** All 10% speed is taken at 5Hz.

## Appendix B—Installation guidelines

**Table 77. 575 V FR4-75hp efficiency rating**

	575 V FR4-75hp																	
	25%Torque						50%Torque						100%Torque					
	Pin (kW)	Pout (kW)	Ploss (kW)	Ploss (%)	Power factor output	Efficiency (%)	Pin (kW)	Pout (kW)	Ploss (kW)	Ploss (%)	Power factor output	Efficiency (%)	Pin (kW)	Pout (kW)	Ploss (kW)	Ploss (%)	Power factor output	Efficiency (%)
10%Speed	0.959	0.768	0.191	19.92%	0.347	80.03%	1.648	1.43	0.218	13.23%	0.516	86.61%	3.23	2.93	0.3	9.29%	0.686	90.72%
50%Speed	4.49	4.27	0.22	4.90%	0.318	95.01%	7.994	7.728	0.266	3.33%	0.514	96.80%	15.82	15.45	0.37	2.34%	0.745	97.66%
90%Speed	7.634	7.424	0.21	2.75%	0.406	97.24%	13.928	13.665	0.263	1.89%	0.626	98.11%	28.16	27.682	0.478	1.70%	0.821	98.42%
100%Speed	8.35	8.13	0.22	2.63%	0.485	97.31%	15.371	15.1	0.271	1.76%	0.703	98.23%	31.148	30.664	0.484	1.55%	0.846	98.45%

**Note:** All 10% speed is taken at 5Hz.

**Table 78. 575 V FR5-150hp efficiency rating**

	575 V FR5-150hp																	
	25%Torque						50%Torque						100%Torque					
	Pin (kW)	Pout (kW)	Ploss (kW)	Ploss (%)	Power factor output	Efficiency (%)	Pin (kW)	Pout (kW)	Ploss (kW)	Ploss (%)	Power factor output	Efficiency (%)	Pin (kW)	Pout (kW)	Ploss (kW)	Ploss (%)	Power factor output	Efficiency (%)
10%Speed	3.157	2.692	0.465	14.73%	0.594	85.30%	5.838	5.19	0.648	11.10%	0.753	88.91%	11.696	10.562	1.134	9.70%	0.826	90.30%
50%Speed	16.472	15.93	0.542	3.29%	0.582	96.71%	31.784	30.996	0.788	2.48%	0.785	97.52%	61.081	59.617	1.464	2.40%	0.872	97.60%
90%Speed	28.182	27.596	0.586	2.08%	0.569	97.92%	54.26	53.42	0.84	1.55%	0.773	98.45%	105.47	103.875	1.595	1.51%	0.866	98.49%
100%Speed	30.804	30.25	0.554	1.80%	0.614	98.22%	59.65	58.775	0.875	1.47%	0.802	98.53%	116.102	114.431	1.671	1.44%	0.873	98.56%

**Note:** All 10% speed is taken at 5Hz.



## Appendix C—Dimension drawings

Approximate Dimensions in Inches (mm)

Figure 40. FR0 Dimension drawing

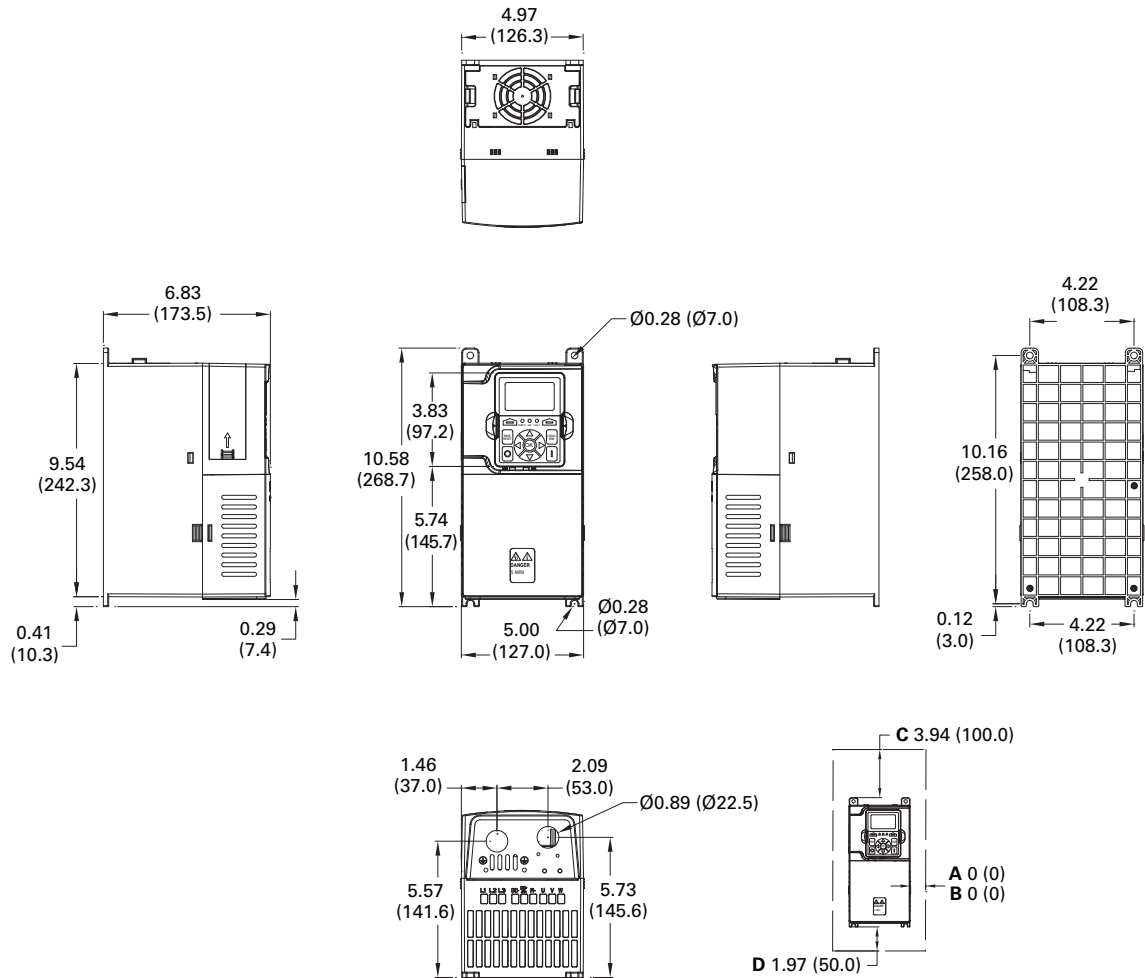

### Minimum Dimensions

- A = Air gap around drive  
(between drive and cabinet)
- B = Space between two drives
- C = Free space above drive
- D = Free space below drive

# Appendix C—Dimension drawings

Approximate dimensions in Inches (mm)

**Figure 41. FR1 Dimension drawing**

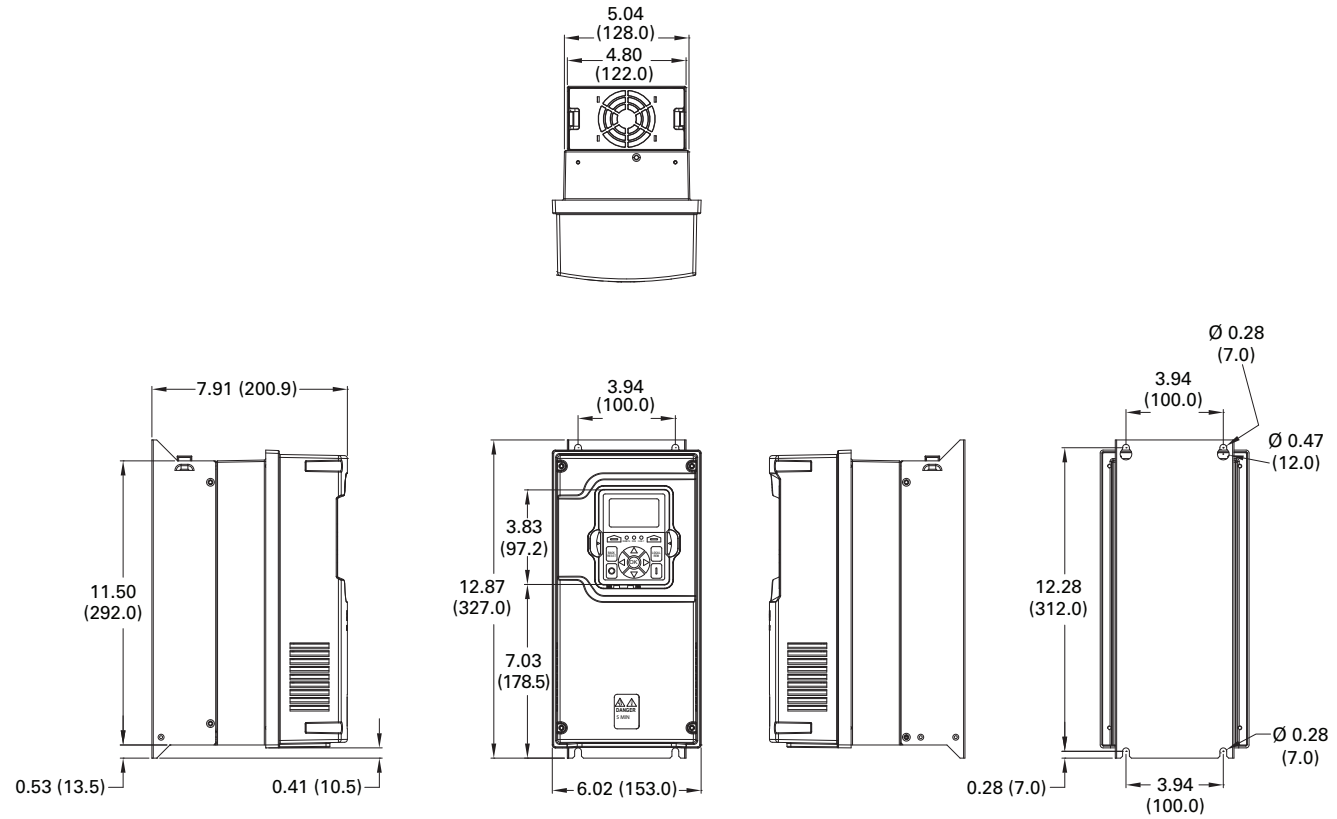

**IP21/IP54 Metric**

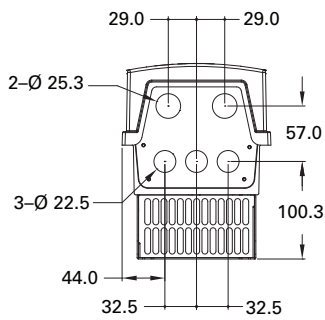

**Type 1/12 UL**

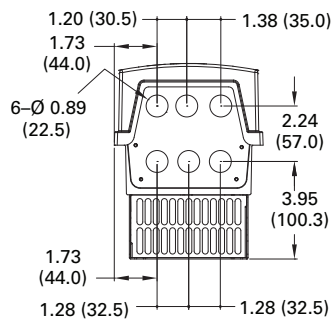

**C 3.94 (100.0)**

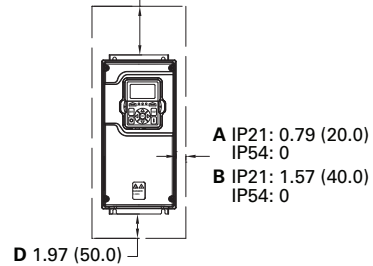

**Minimum Dimensions**

- A** = Air gap around drive  
(between drive and cabinet)
- B** = Space between two drives
- C** = Free space above drive
- D** = Free space below drive

Approximate dimensions in Inches (mm)

Figure 42. FR1 Dimension drawing flange mount

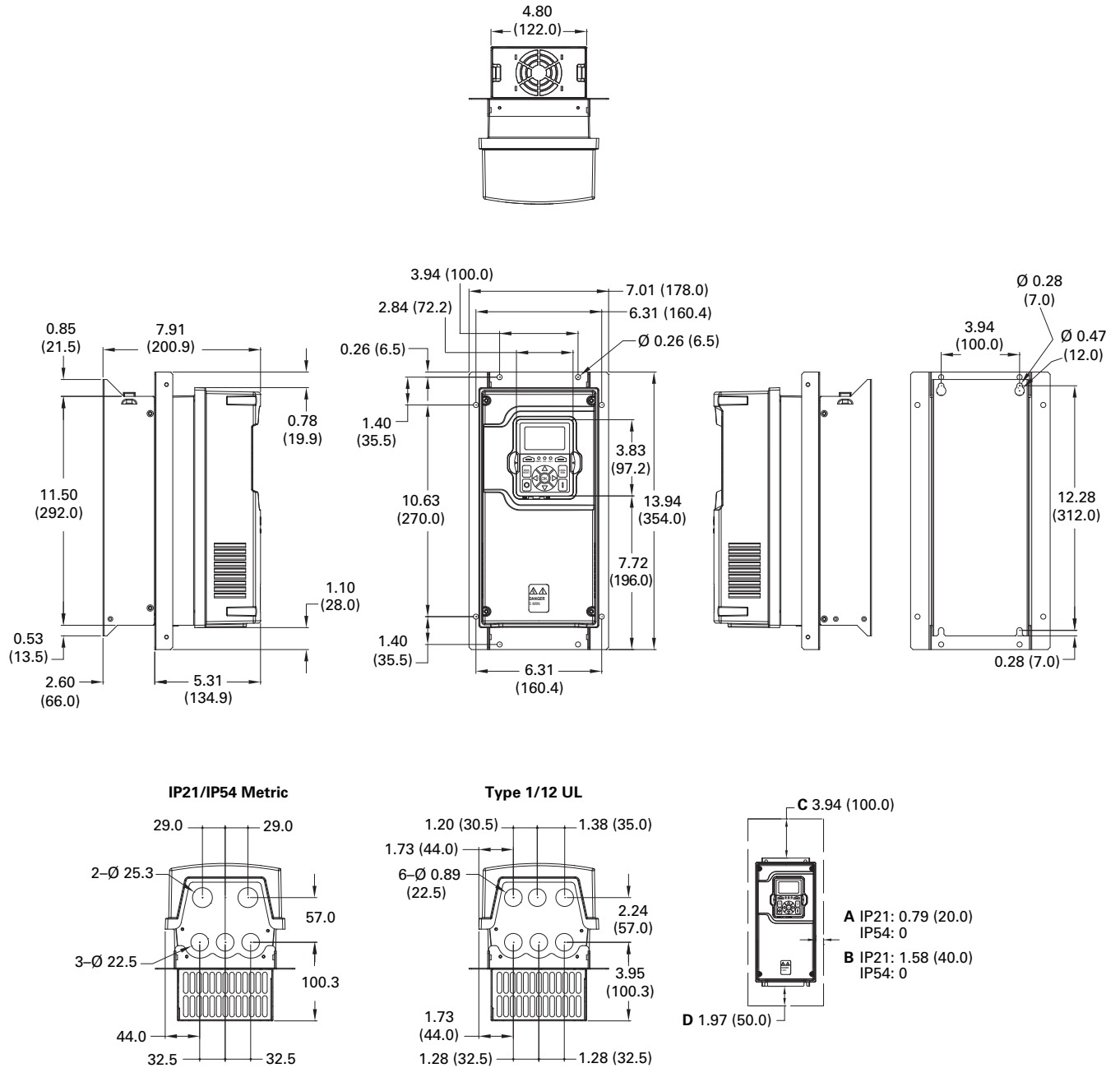

# Appendix C—Dimension drawings

Approximate dimensions in Inches (mm)

**Figure 43. FR2 Dimension drawing**

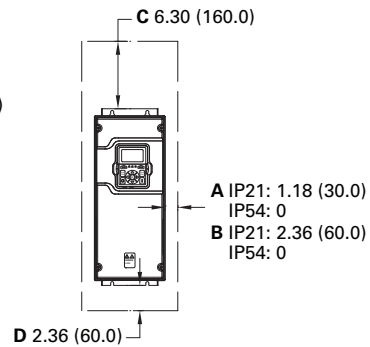
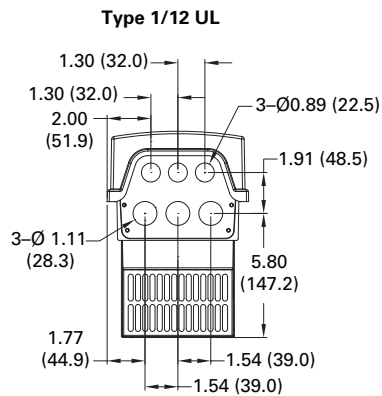
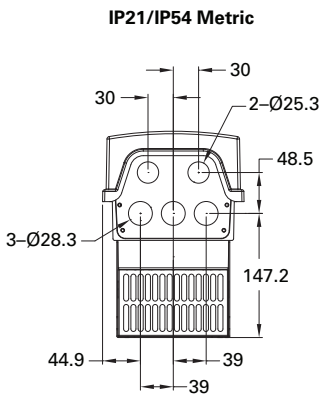
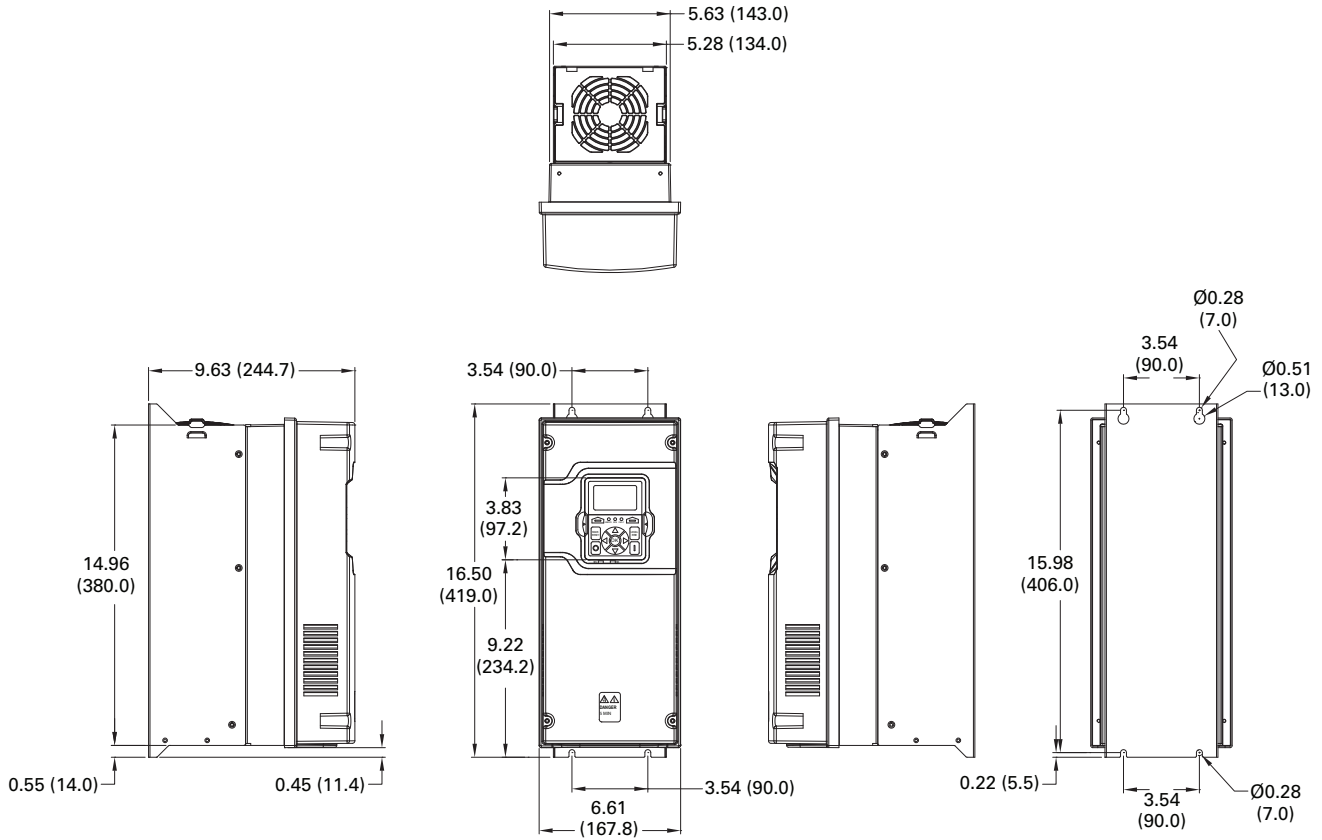

**Minimum Dimensions**

- A = Air gap around drive (between drive and cabinet)
- B = Space between two drives
- C = Free space above drive
- D = Free space below drive

Approximate dimensions in Inches (mm)

Figure 44. FR2 Dimension drawing flange mount

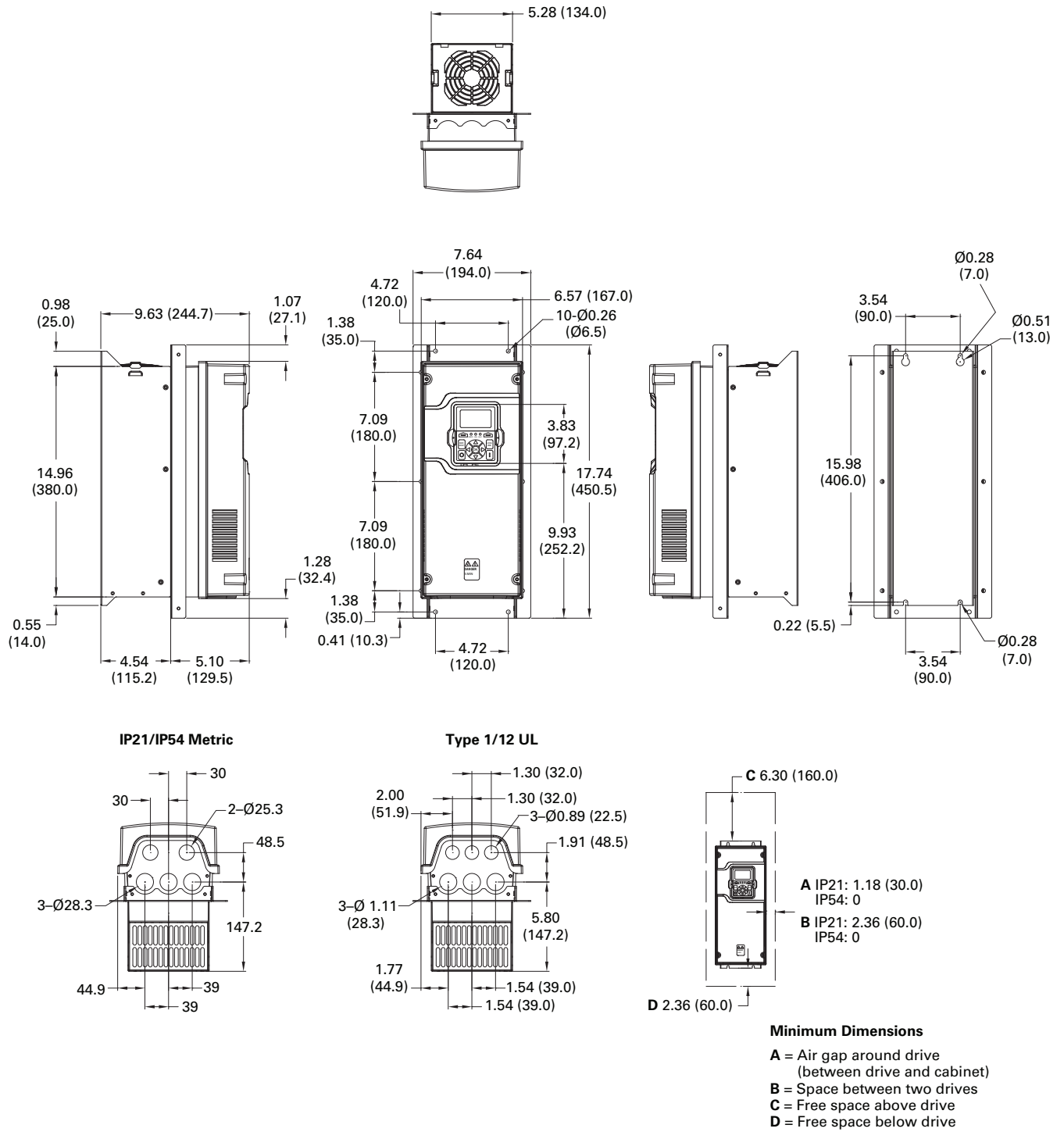

# Appendix C—Dimension drawings

Approximate dimensions in Inches (mm)

**Figure 45. FR3 Dimension drawing**

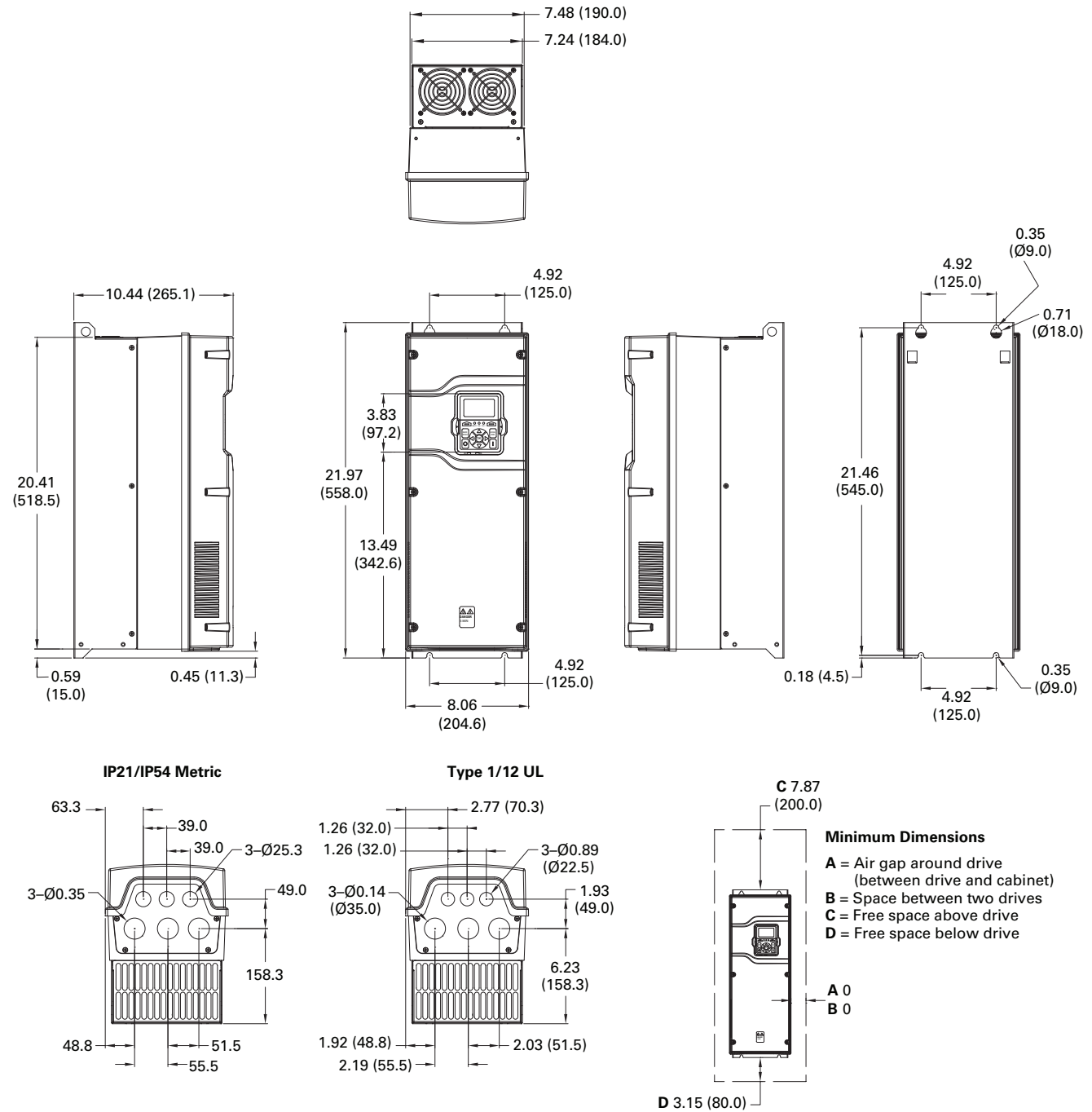

Approximate dimensions in Inches (mm)

Figure 46. FR3 Dimension drawing flange mount

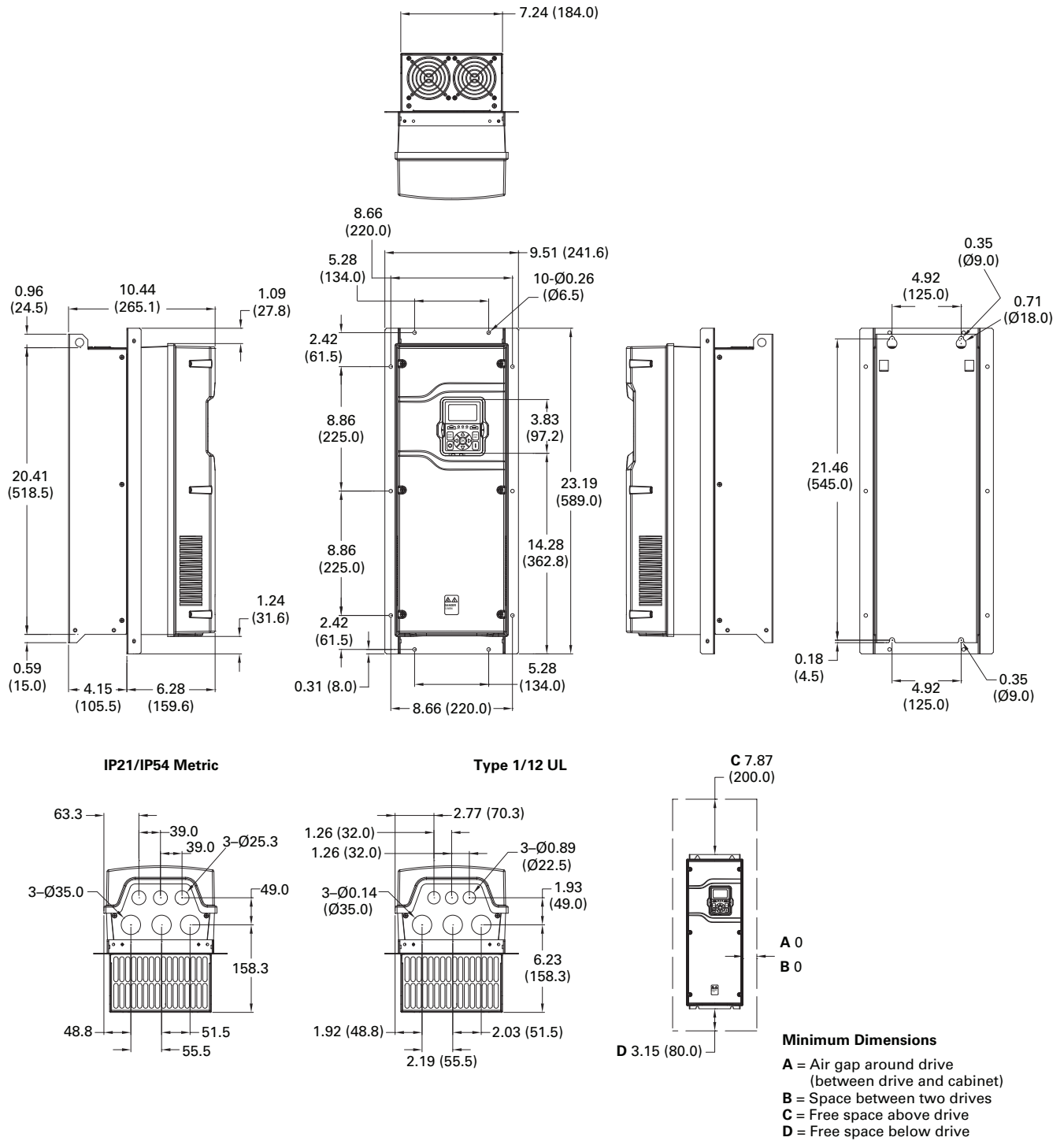

# Appendix C—Dimension drawings

Approximate dimensions in Inches (mm)

**Figure 47. FR4 Dimension drawing**

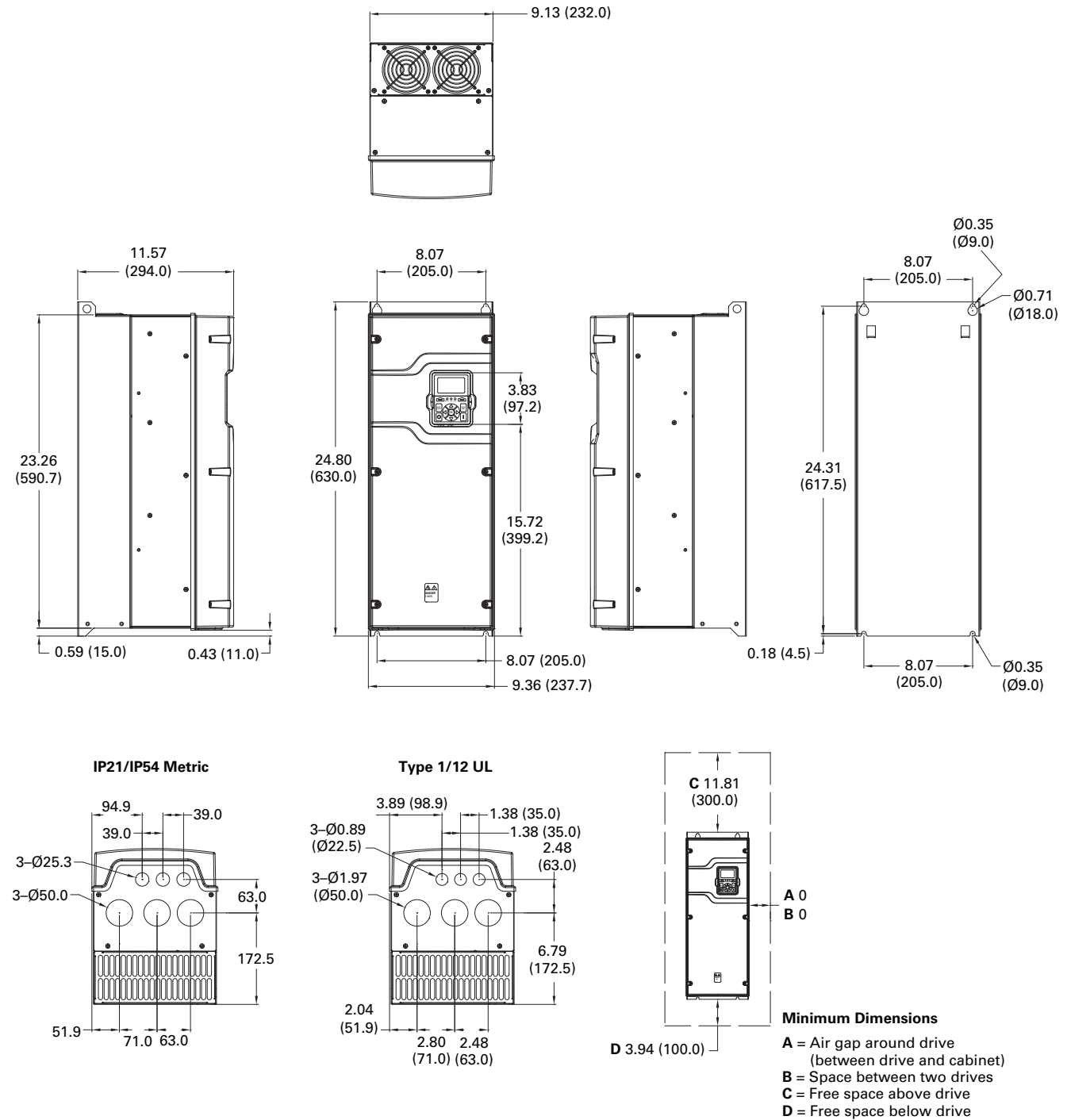



Approximate dimensions in Inches (mm)

Figure 48. FR4 Dimension drawing flange mount

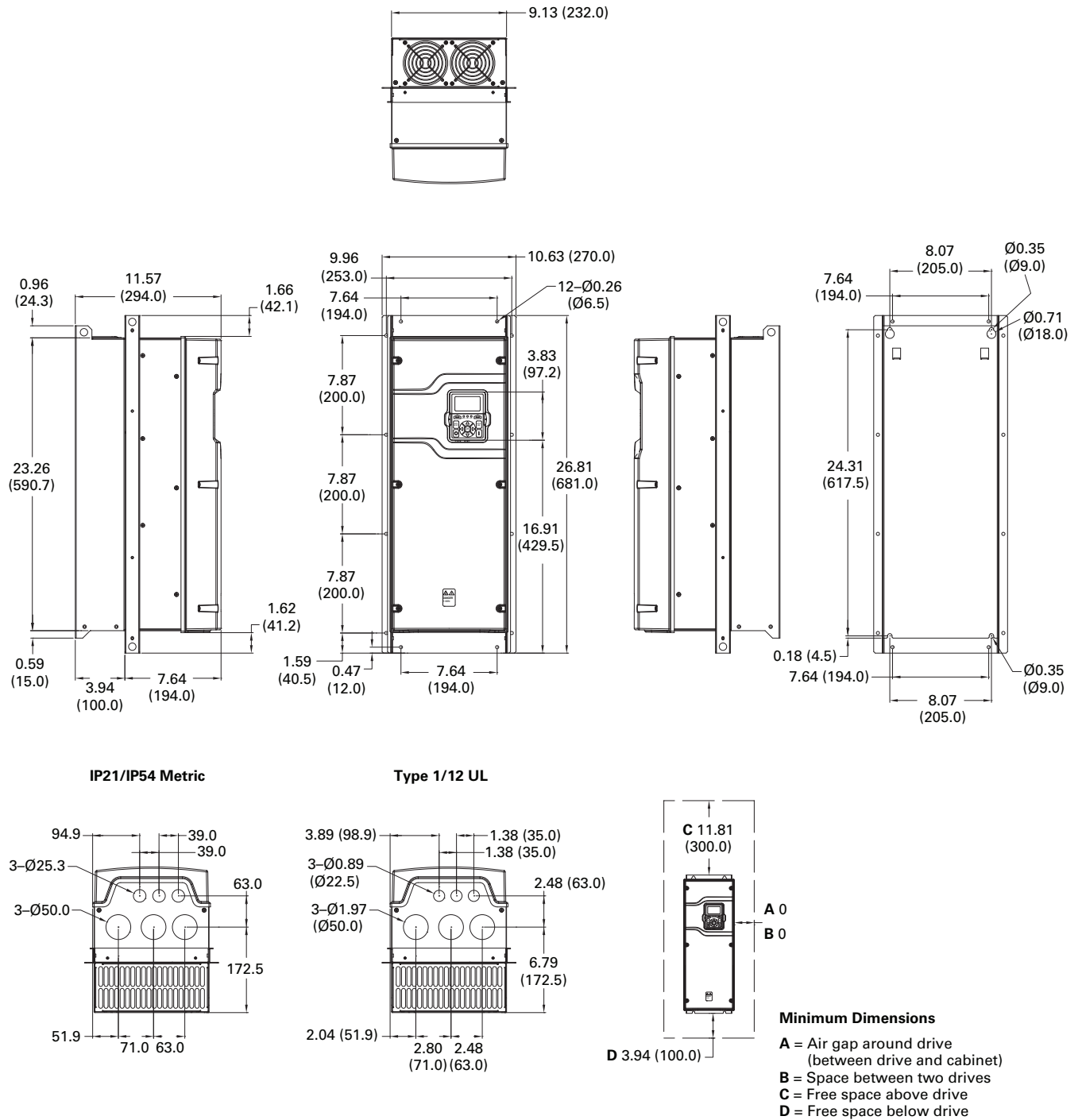

# Appendix C—Dimension drawings

Approximate dimensions in Inches (mm)

**Figure 49. FR5 Dimension drawing**

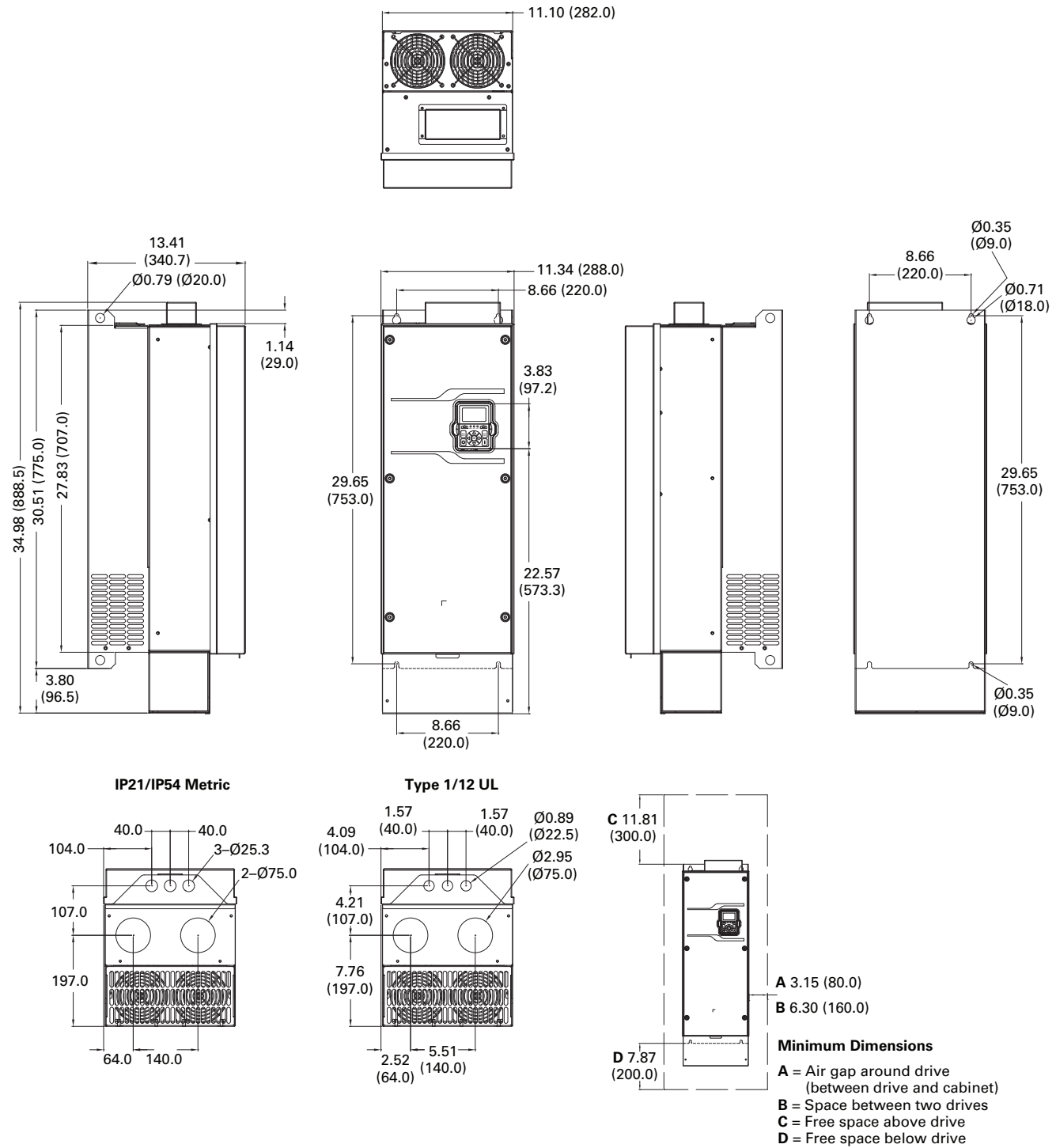

Approximate dimensions in Inches (mm)

Figure 50. FR5 Dimension drawing flange mount

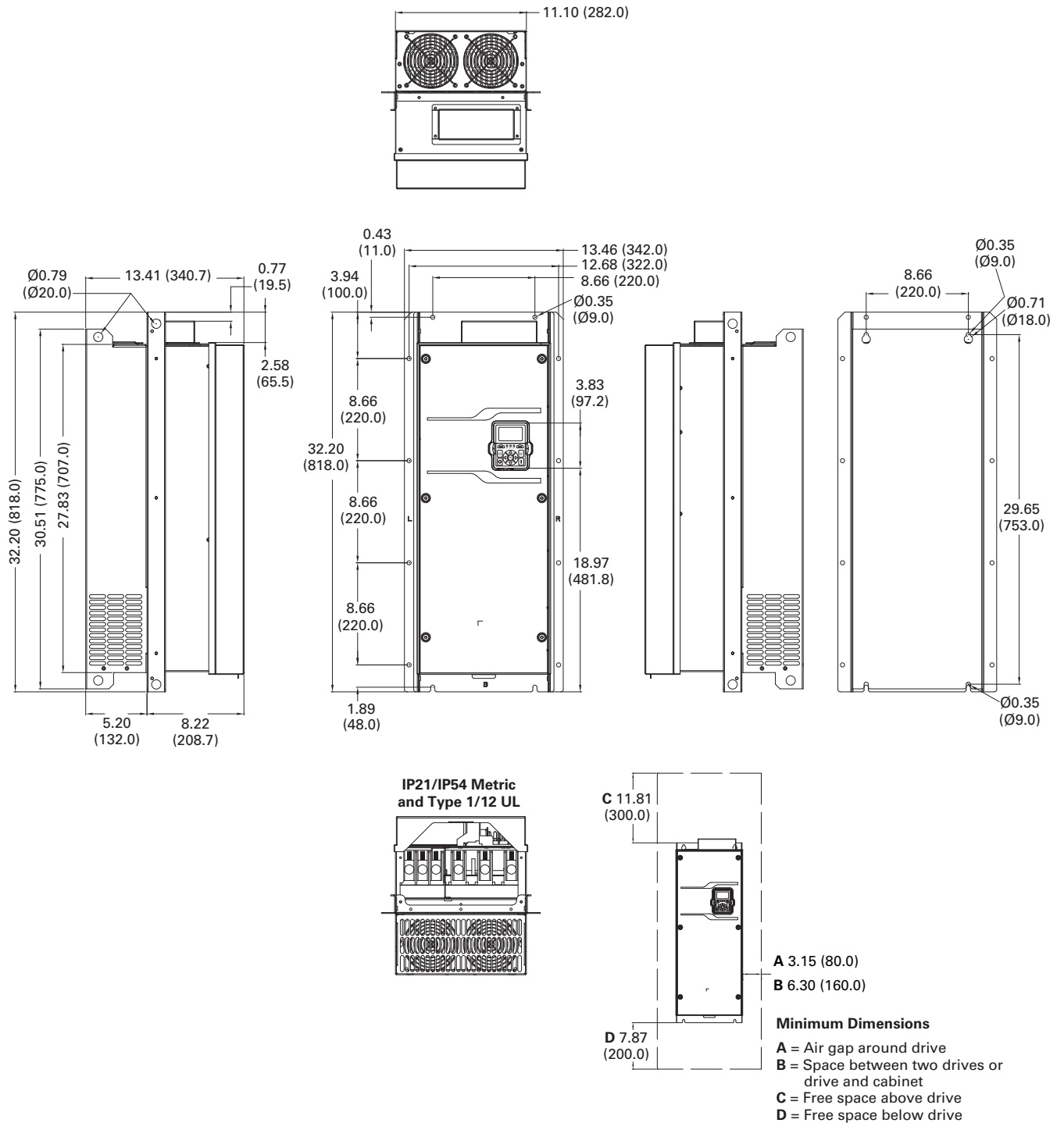

# Appendix C—Dimension drawings

Approximate dimensions in Inches (mm)

**Figure 51. FR6 Dimensional drawing**

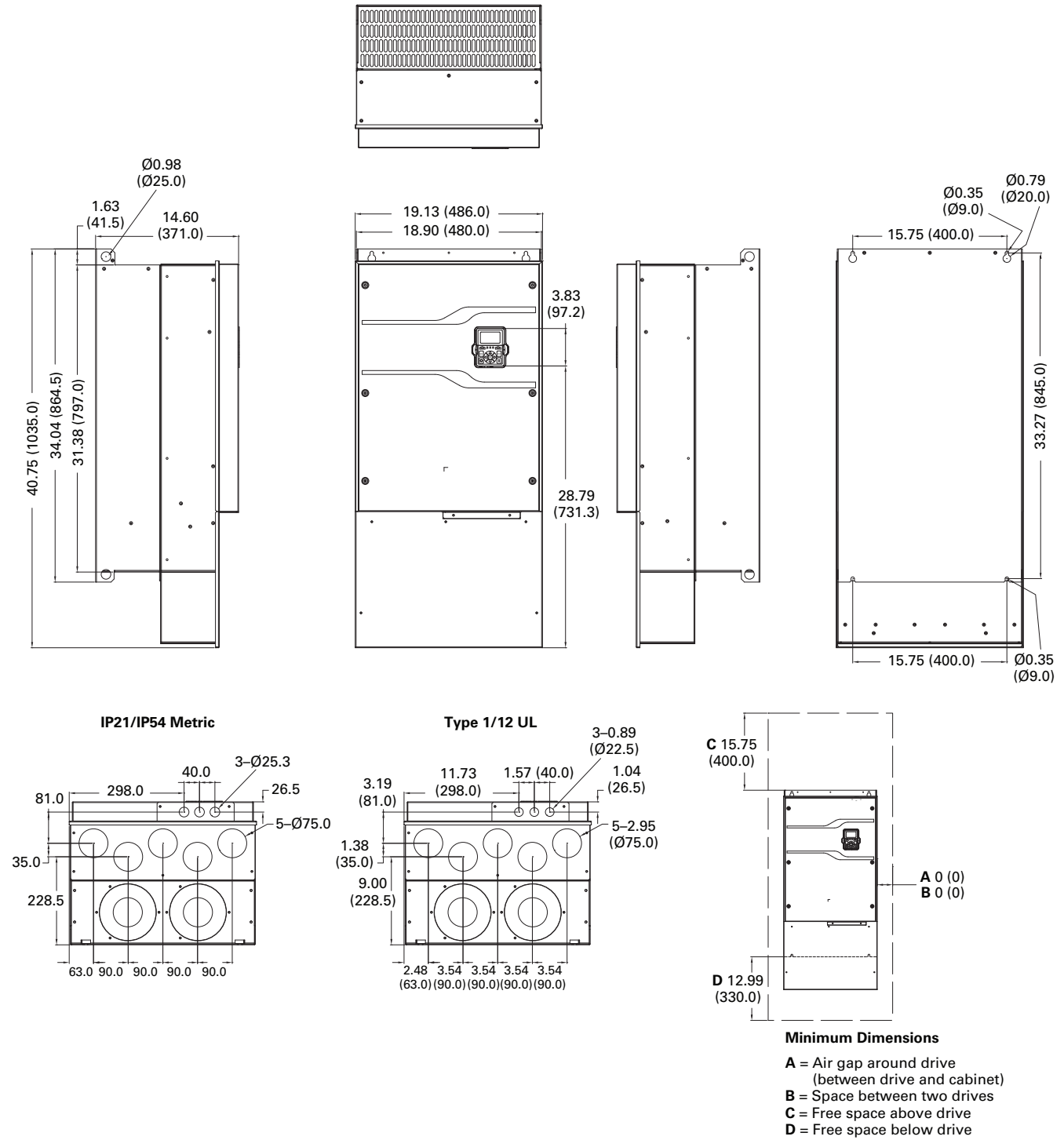

Approximate dimensions in Inches (mm)

Figure 52. FR6 Dimensional drawing flange mount

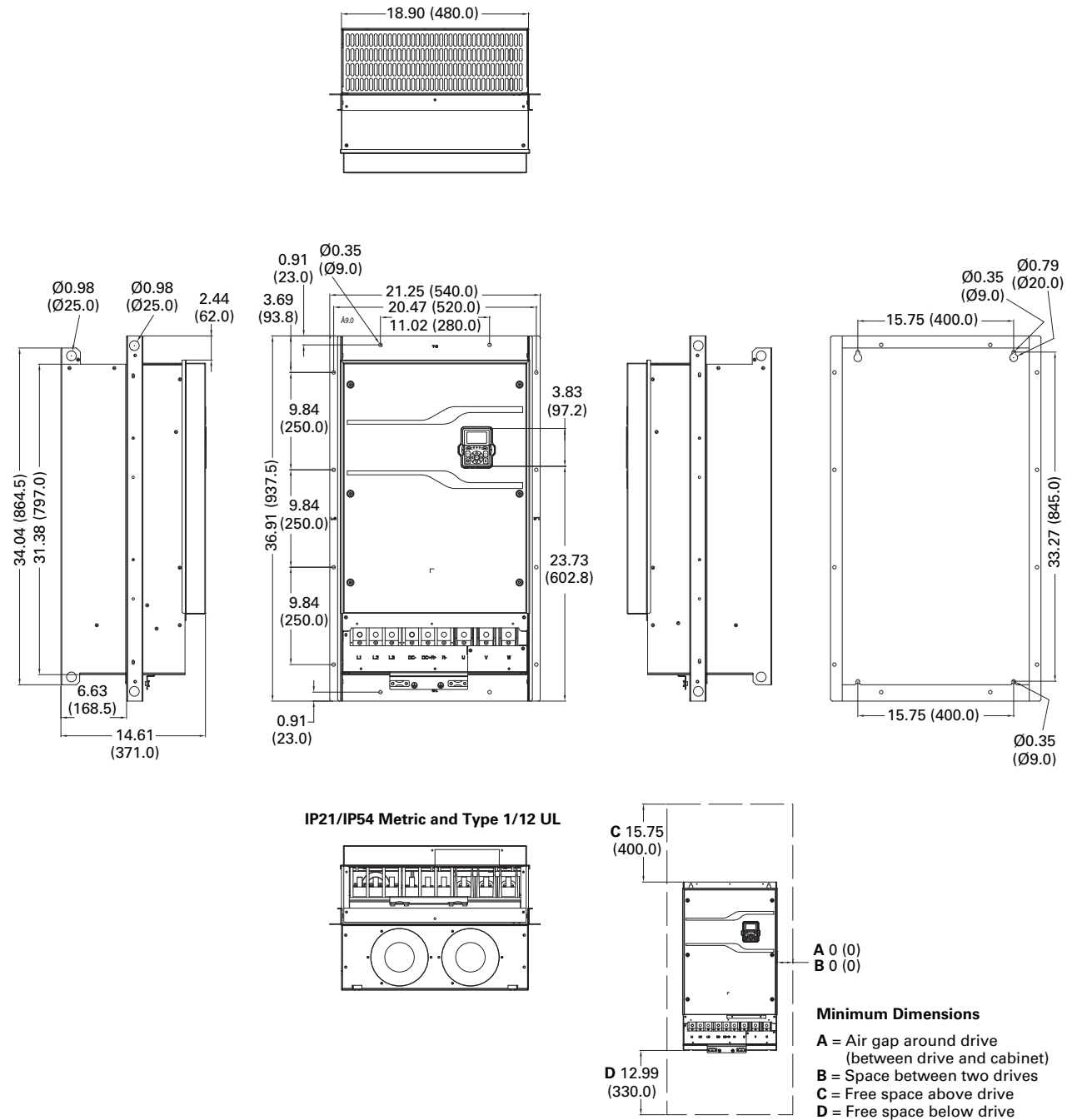

## Appendix D—Safety instructions for UL and cUL

---

### CAUTION

---

The UL and cUL compliance can be maintained only if this drive is installed according to the requirements of Appendix D —Safety Instructions for UL and cUL. Failure to follow these instructions may result in UL and cUL non-compliance.

#### UL Standards compliance

This drive is tested in accordance with UL508C and CSA C22.2 No. 274-13 and CSA C22.2 No. 274-17 and is found to comply with these requirements. To ensure continued compliance when using this drive or when using it in combination with other equipment, meet the following conditions.

#### General

This drive shall be applied in accordance with the specifications detailed in **Table 24**.

#### Overvoltage category

To comply with standard CSA C22.2 No. 274-13 and CSA C22.2 No. 274-17 requirement, the following applies to cUL applications:

- This drive should be installed in environment of Overvoltage Category III
- **For 480 V Series:** It is recommended that transient surge suppression be installed on the line side of this equipment and be rated 500 V (phase to ground), suitable for Overvoltage Category III, and shall provide protection for a rated impulse withstand voltage peak of 6 kV
- **For 230 V Series:** It is recommended that transient surge suppression be installed on the line side of this equipment and be rated 240 V (phase to ground), suitable for Overvoltage Category III, and provide protection for a rated impulse withstand voltage peak of 4 kV
- **For 575 V Series:** It is recommended that transient surge suppression be installed on the line side of this equipment and be rated 600 V (phase to ground), suitable for Overvoltage Category III, and shall provide protection for a rated impulse withstand voltage peak of 6 kV

#### Motor overload and over-temperature protection

This drive provides solid-state motor overload protection. The solid-state motor overload protection limit is adjustable, see the drives application manual for more details.

This drive can accept and act upon a signal from a thermal sensor or switch embedded in the motor or from an external protective relay to achieve the motor over temperature protection. Therefore, in order to achieve the motor over temperature protection, a sensor from the motor will be needed.

### Branch circuit short circuit protection

Integral solid-state short circuit protection does not provide branch circuit protection. Branch circuit protection must be provided in accordance with the National Electrical Code and any additional local codes.

480 V Drive Series are suitable for use on a circuit capable of delivering not more than 100,000 rms symmetrical amperes, 500 volts maximum, when protected by UL and cUL/CSA Listed devices mentioned below with an A.I.C. rating of 100 kA minimum.

- Class RK5, Class J, Class T or equivalent fuses
- Thermal-magnetic circuit breakers
- Magnetic only circuit breakers (Eaton Type HMCP)

Refer to the following information for recommended ratings. See **Table 79**.

**Table 79. Protection ratings—480 V drive series**

Frame size	DG1 catalog number	DH1 catalog number	Maximum fuse rating ①	Maximum thermal-magnetic breaker rating ①	Magnetic only circuit breakers	
					Maximum magnetic breaker rating ①	Maximum rated Eaton type HMCP ①
0	DG1-342D2EB-C20C	DH1-343D3EB-C20C ②	600 V, 10 A	480 V, 15 A	480 V, 7 A	HMCP007C0C
	DG1-343D3EB-C20C	DH1-344D3EB-C20C ②	600 V, 10 A	480 V, 15 A	480 V, 15 A	HMCP015E0C
	DG1-344D3EB-C20C	DH1-345D6EB-C20C ②	600 V, 15 A	480 V, 15 A	480 V, 15 A	HMCP015E0C
	DG1-345D6EB-C20C	DH1-347D6EB-C20C ②	600 V, 15 A	480 V, 15 A	480 V, 25A	HMCP025D0C
1	DG1-342D2xx-xxxx	DH1-343D3XX-CXXC	600 V, 10 A	480 V, 15 A	480 V, 7 A	HMCP007C0C
	DG1-343D3xx-xxxx	DH1-344D3XX-CXXC	600 V, 10 A	480 V, 15 A	480 V, 15 A	HMCP015E0C
	DG1-344D3xx-xxxx	DH1-345D6XX-CXXC	600 V, 15 A	480 V, 15 A	480 V, 15 A	HMCP015E0C
	DG1-345D6xx-xxxx	DH1-347D6XX-CXXC	600 V, 15 A	480 V, 15 A	480 V, 25 A	HMCP025D0C
	DG1-347D6xx-xxxx	DH1-349D0XX-CXXC	600 V, 15 A	480 V, 15 A	480 V, 25 A	HMCP025D0C
	DG1-349D0xx-xxxx	DH1-34012XX-CXXC	600 V, 15 A	480 V, 15 A	480 V, 25 A	HMCP025D0C
2	DG1-34012xx-xxxx	DH1-34016XX-CXXC	600 V, 35 A	480 V, 35 A	480 V, 50 A	HMCP050K2C
	DG1-34016xx-xxxx	DH1-34023XX-CXXC	600 V, 60 A	480 V, 60 A	480 V, 70 A	HMCP070M2C
	DG1-34023xx-xxxx	DH1-34031XX-CXXC	600 V, 80 A	480 V, 80 A	480 V, 100 A	HMCP100R3C
3	DG1-34031xx-xxxx	DH1-34038XX-CXXC	600 V, 90 A	480 V, 90 A	480 V, 100 A	HMCP100R3C
	DG1-34038xx-xxxx	DH1-34046XX-CXXC	600 V, 100 A	480 V, 100 A	480 V, 100 A	HMCP100R3C
	DG1-34046xx-xxxx	DH1-34061XX-CXXC	600 V, 150 A	480 V, 150 A	480 V, 100 A	HMCP100R3C
4	DG1-34061xx-xxxx	DH1-34072XX-CXXC	600 V, 175 A	480 V, 175 A	480 V, 250 A	HMCP250W5C
	DG1-34072xx-xxxx	DH1-34087XX-CXXC	600 V, 200 A	480 V, 200 A	480 V, 250 A	HMCP250W5C
	DG1-34087xx-xxxx	DH1-34105XX-CXXC	600 V, 300 A	480 V, 300 A	480 V, 400 A	HMCP400W5C
5	DG1-34105xx-xxxx	DH1-34140XX-CXXC	600 V, 350 A	480 V, 350 A	480 V, 400 A	HMCP400N5C
	DG1-34140xx-xxxx	DH1-34170XX-CXXC	600 V, 400 A	480 V, 400 A	480 V, 400 A	HMCP400N5C
	DG1-34170xx-xxxx	DH1-34205XX-CXXC	600 V, 400 A	480 V, 400 A	480 V, 400 A	HMCP400N5C
6	DG1-34205xx-xxxx	DH1-34261XX-CXXC	600 V, 400 A	480 V, 400 A	480 V, 400 A	HMCP400N5C
	DG1-34245xx-xxxx	DH1-34310XX-CXXC	600 V, 400 A	480 V, 400 A	480 V, 400 A	HMCP400N5C

**Notes:** ① These ratings are based off the largest wire size designed for the given Frame. Please verify your protection protects your wire sizing. See Appendix B for recommended fuse and wire size.

② IP20 FR0 will be available in June 2018.

## Appendix D—Safety instructions for UL and cUL

230 V Drive Series are suitable for use on a circuit capable of delivering not more than 100,000 rms symmetrical amperes, 240 volts maximum when protected by UL and cUL/CSA Listed devices mentioned below with an A.I.C. rating of 100 kA minimum.

- Class RK5, Class J, Class T or equivalent fuses
- Thermal-magnetic circuit breakers
- Magnetic only circuit breakers (Eaton Type HMCP)

Refer to the following information for recommended ratings. See **Table 80**.

**Table 80. Protection ratings—230 V drive series**

Frame size	DG1 catalog number	DH1 catalog number	Maximum fuse rating ①	Maximum thermal-magnetic breaker rating ①	Magnetic only circuit breakers	
					Maximum magnetic breaker rating ①	Maximum rated Eaton type HMCP ①
0	DG1-323D7EB-C20C	DH1-324D8EB-C20C ②	600 V, 15 A	480 V, 15 A	480 V, 15 A	HMCP015E0C
	DG1-324D8EB-C20C	DH1-326D6EB-C20C ②	600 V, 20 A	480 V, 20 A	480 V, 25 A	HMCP025D0C
	DG1-326D6EB-C20C	DH1-327D8EB-C20C ②	600 V, 20 A	480 V, 20 A	480 V, 25 A	HMCP025D0C
1	DG1-323D7xx-xxxx	DH1-324D8XX-CXXC	600 V, 15 A	480 V, 15 A	480 V, 15 A	HMCP015E0C
	DG1-324D8xx-xxxx	DH1-326D6XX-CXXC	600 V, 20 A	480 V, 20 A	480 V, 25 A	HMCP025D0C
	DG1-326D6xx-xxxx	DH1-327D8XX-CXXC	600 V, 20 A	480 V, 20 A	480 V, 25 A	HMCP025D0C
	DG1-327D8xx-xxxx	DH1-32011XX-CXXC	600 V, 30 A	480 V, 30 A	480 V, 30 A	HMCP030H1C
	DG1-32011xx-xxxx	DH1-32012XX-CXXC	600 V, 30 A	480 V, 30 A	480 V, 30 A	HMCP030H1C
2	DG1-32012xx-xxxx	DH1-32017XX-CXXC	600 V, 40 A	480 V, 40 A	480 V, 50 A	HMCP050K2C
	DG1-32017xx-xxxx	DH1-32025XX-CXXC	600 V, 40 A	480 V, 40 A	480 V, 50 A	HMCP050K2C
	DG1-32025xx-xxxx	DH1-32031XX-CXXC	600 V, 40 A	480 V, 40 A	480 V, 50 A	HMCP050K2C
3	DG1-32031xx-xxxx	DH1-32048XX-CXXC	600 V, 125 A	480 V, 125 A	480 V, 150 A	HMCP150U4C
	DG1-32048xx-xxxx	DH1-32061XX-CXXC	600 V, 150 A	480 V, 150 A	480 V, 150 A	HMCP150U4C
4	DG1-32061xx-xxxx	DH1-32075XX-CXXC	600 V, 200 A	480 V, 200 A	480 V, 250 A	HMCP250W5C
	DG1-32075xx-xxxx	DH1-32088XX-CXXC	600 V, 225 A	480 V, 225 A	480 V, 250 A	HMCP250W5C
	DG1-32088xx-xxxx	DH1-32114XX-CXXC	600 V, 300 A	480 V, 300 A	480 V, 400 A	HMCP400W5C
5	DG1-32114xx-xxxx	DH1-32143XX-CXXC	600 V, 400 A	480 V, 400 A	480 V, 400 A	HMCP400N5C
	DG1-32143xx-xxxx	DH1-32170XX-CXXC	600 V, 400 A	480 V, 400 A	480 V, 400 A	HMCP400N5C
	DG1-32170xx-xxxx	DH1-32211XX-CXXC	600 V, 400 A	480 V, 400 A	480 V, 400 A	HMCP400N5C
6	DG1-32211xx-xxxx	DH1-32261XX-CXXC	600 V, 400 A	480 V, 400 A	480 V, 400 A	HMCP400N5C
	DG1-32248xx-xxxx	DH1-32312XX-CXXC	600 V, 400 A	480 V, 400 A	480 V, 400 A	HMCP400N5C

**Notes:** ① These ratings are based off the largest wire size designed for the given Frame. Please verify your protection protects your wire sizing. See Appendix B for recommended fuse and wire size.

② IP20 FR0 will be available in June 2018.



575 V Drive Series are suitable for use on a circuit capable of delivering not more than 100,000 rms symmetrical amperes, 600 volts maximum, when protected by UL and cUL/CSA Listed devices mentioned below with an A.I.C. rating of 100 kA minimum.

- Class RK5, Class J, Class T or equivalent fuses
- Thermal-magnetic circuit breakers (see Note below)
- Current limiting circuit breakers (for FR1-3 only)

**Note:** When protected by UL and cUL/CSA Listed Thermal-magnetic circuit breakers:

- FR0–3 are only suitable for use on a circuit capable of delivering not more than 35,000 rms symmetrical amperes, 600 volts maximum
- FR4–6 are only suitable for use on a circuit capable of delivering not more than 65,000 rms symmetrical amperes, 600 volts maximum

Refer to the following information for recommended ratings. See **Table 81**.

**Table 81. Protection ratings—575 V drive series**

Frame size	DG1 catalog number	DH1 catalog number	Maximum fuse rating ①	Maximum thermal-magnetic breaker rating ①	Maximum current limiting breaker ratings ①
1	DG1-353D3xx-xxxx	DH1-354D5XX-CXXC	600 V, 10 A	600 V, 15 A	600 V, 15 A
	DG1-354D5xx-xxxx	DH1-357D5XX-CXXC	600 V, 20 A	600 V, 20 A	600 V, 20 A
	DG1-357D5xx-xxxx	DH1-35010XX-CXXC	600 V, 30 A	600 V, 30 A	600 V, 30 A
2	DG1-35010xx-xxxx	DH1-35013XX-CXXC	600 V, 35 A	600 V, 35 A	600 V, 35 A
	DG1-35013xx-xxxx	DH1-35018XX-CXXC	600 V, 60 A	600 V, 60 A	600 V, 60 A
	DG1-35018xx-xxxx	DH1-35022XX-CXXC	600 V, 80 A	600 V, 80 A	600 V, 80 A
3	DG1-35022xx-xxxx	DH1-35027XX-CXXC	600 V, 80 A	600 V, 90 A	600 V, 90 A
	DG1-35027xx-xxxx	DH1-35034XX-CXXC	600 V, 80 A	600 V, 100 A	600 V, 100 A
	DG1-35034xx-xxxx	DH1-35041XX-CXXC	600 V, 80 A	600 V, 150 A	600 V, 150 A
4	DG1-35041xx-xxxx	DH1-35052XX-CXXC	600 V, 150 A	600 V, 175 A	N/A
	DG1-35052xx-xxxx	DH1-35062XX-CXXC	600 V, 150 A	600 V, 200 A	N/A
	DG1-35062xx-xxxx	DH1-35080XX-CXXC	600 V, 150 A	600 V, 300 A	N/A
5	DG1-35080xx-xxxx	DH1-35100XX-CXXC	600 V, 200 A	600 V, 225 A	N/A
	DG1-35100xx-xxxx	DH1-35125XX-CXXC	600 V, 200 A	600 V, 225 A	N/A
	DG1-35125xx-xxxx	DH1-35144XX-CXXC	600 V, 200 A	600 V, 300 A	N/A
6	DG1-35144xx-xxxx	DH1-35208XX-CXXC	600 V, 400 A	600 V, 400 A	N/A
	DG1-35208xx-xxxx	DH1-35250XX-CXXC	600 V, 400 A	600 V, 400 A	N/A

**Notes:** ① These ratings are based off the largest wire size designed for the given Frame. Please verify your protection protects your wire sizing. See Appendix B for recommended fuse and wire size.  
 ② IP20 FR0 will be available in June 2018.

**Field wiring**

- The field installed conductors for this drive should be 75 °C or higher copper wire
- The enclosure openings provided for conduit connections in the field shall be closed by UL Listed conduit fittings with same type rating as the enclosure (Type 1/Type 12)

## Appendix D—Safety instructions for UL and cUL

### Line and motor wiring

- For 480 V Drive Series, required line and motor wire torque, type and size range are listed in **Table 82**

**Table 82. Required line and motor wire torque (480 V)**

DG1 catalog number	DH1 catalog number	Terminal type	Required torque (in-lb)	Required wire range
<b>FR0</b>				
DG1-342D2EB-C20C	DH1-343D3EB-C20C ①	L1, L2, L3, DC+, DC-, R+, R-, U, V, W	5.3	14–10 AWG
DG1-343D3EB-C20C	DH1-344D3EB-C20C ①		5.3	14–10 AWG
DG1-344D3EB-C20C	DH1-345D6EB-C20C ①		5.3	14–10 AWG
DG1-345D6EB-C20C	DH1-347D6EB-C20C ①		5.3	14–10 AWG
<b>FR1</b>				
DG1-342D2xx-xxxx	DH1-343D3XX-XXXX	L1, L2, L3, DC+, DC-, R+, R-, U, V, W	5.3	14–10 AWG
DG1-343D3xx-xxxx	DH1-344D3XX-XXXX		5.3	14–10 AWG
DG1-344D3xx-xxxx	DH1-345D6XX-XXXX		5.3	14–10 AWG
DG1-345D6xx-xxxx	DH1-347D6XX-XXXX		5.3	14–10 AWG
DG1-347D6xx-xxxx	DH1-349D0XX-XXXX		5.3	14–10 AWG
DG1-349D0xx-xxxx	DH1-34012XX-XXXX		5.3	14–10 AWG
<b>FR2</b>				
DG1-34012xx-xxxx	DH1-34016XX-XXXX	L1, L2, L3, DC+, DC-, R+, R-, U, V, W	15.6	12–6 AWG
DG1-34016xx-xxxx	DH1-34023XX-XXXX		15.6	10–6 AWG
DG1-34023xx-xxxx	DH1-34031XX-XXXX		15.6	8–6 AWG
<b>FR3</b>				
DG1-34031xx-xxxx	DH1-34038XX-XXXX	L1, L2, L3, DC+, DC-, R+, R-, U, V, W	40	6–2 AWG
DG1-34038xx-xxxx	DH1-34046XX-XXXX		40	6–2 AWG
DG1-34046xx-xxxx	DH1-34061XX-XXXX		40	4–2 AWG
<b>FR4</b>				
DG1-34061xx-xxxx	DH1-34072XX-XXXX	L1, L2, L3, DC+, DC-, R+, R-, U, V, W	95	4–1/0 AWG
DG1-34072xx-xxxx	DH1-34087XX-XXXX		95	3–1/0 AWG
DG1-34087xx-xxxx	DH1-34105XX-XXXX		95	1–1/0 AWG
<b>FR5</b>				
DG1-34105xx-xxxx	DH1-34140XX-XXXX	L1, L2, L3, DC+, DC-, R+, R-, U, V, W	354	2/0 AWG–350 kcmil
DG1-34140xx-xxxx	DH1-34170XX-XXXX		354	3/0 AWG–350 kcmil
DG1-34170xx-xxxx	DH1-34205XX-XXXX		354	250–350 kcmil
<b>FR6</b>				
DG1-34205xx-xxxx	DH1-34261XX-XXXX	L1, L2, L3, DC+, DC-, R+, R-, U, V, W	480	2*(2/0–300 kcmil)
DG1-34245xx-xxxx	DH1-34310XX-XXXX		480	2*(4/0–300 kcmil)
<b>All Frames Sizes (FR0–FR6)</b>				
<b>All models</b>		Control terminal block	4.5	28–12 (Sol) AWG 30–12 (Str) AWG

**Note:** ① IP20 FR0 will be available in June 2018.

- For 230 V Drive Series, required line and motor wire torque, type and size range are listed in **Table 83**

**Table 83. Required line and motor wire torque (230 V)**

DG1 catalog number	DH1 catalog number	Terminal type	Required torque (in-lb)	Required wire range
<b>FR0</b>				
DG1-323D7EB-C20C	DH1-324D8EB-C20C ①	L1, L2, L3, DC+, DC-, R+, R-, U, V, W	5.3	14–10 AWG
DG1-324D8EB-C20C	DH1-326D6EB-C20C ①		5.3	14–10 AWG
DG1-326D6EB-C20C	DH1-327D8EB-C20C ①		5.3	14–10 AWG
<b>FR1</b>				
DG1-323D7xx-xxxx	DH1-324D8XX-XXXX	L1, L2, L3, DC+, DC-, R+, R-, U, V, W	5.3	14–10 AWG
DG1-324D8xx-xxxx	DH1-326D6XX-XXXX		5.3	14–10 AWG
DG1-326D6xx-xxxx	DH1-327D8XX-XXXX		5.3	14–10 AWG
DG1-327D8xx-xxxx	DH1-32011XX-XXXX		5.3	14–10 AWG
DG1-32011xx-xxxx	DH1-32012XX-XXXX		5.3	12–10 AWG
<b>FR2</b>				
DG1-32012xx-xxxx	DH1-32017XX-XXXX	L1, L2, L3, DC+, DC-, R+, R-, U, V, W	15.6	10–6 AWG
DG1-32017xx-xxxx	DH1-32025XX-XXXX		15.6	8–6 AWG
DG1-32025xx-xxxx	DH1-32031XX-XXXX		15.6	8–6 AWG
<b>FR3</b>				
DG1-32031xx-xxxx	DH1-32048XX-XXXX	L1, L2, L3, DC+, DC-, R+, R-, U, V, W	40	6–2 AWG
DG1-32048xx-xxxx	DH1-32061XX-XXXX		40	4–2 AWG
<b>FR4</b>				
DG1-32061xx-xxxx	DH1-32075XX-XXXX	L1, L2, L3, DC+, DC-, R+, R-, U, V, W	95	3–1/0 AWG
DG1-32075xx-xxxx	DH1-32088XX-XXXX		95	2–1/0 AWG
DG1-32088xx-xxxx ②	DH1-32114XX-XXXX		95	1/0 AWG <sup>1</sup>
<b>FR5</b>				
DG1-32114xx-xxxx	DH1-32143XX-XXXX	L1, L2, L3, DC+, DC-, R+, R-, U, V, W	354	3/0 AWG–350 kcmil
DG1-32143xx-xxxx	DH1-32170XX-XXXX		354	4/0 AWG–350 kcmil
DG1-32170xx-xxxx	DH1-32211XX-XXXX		354	300–350 kcmil
<b>FR6</b>				
DG1-32211xx-xxxx	DH1-32261XX-XXXX	L1, L2, L3, DC+, DC-, R+, R-, U, V, W	480	2*(2/0–300 kcmil)
DG1-32248xx-xxxx	DH1-32312XX-XXXX		480	2*(4/0–300 kcmil)
<b>All Frames Sizes (FR0–FR6)</b>				
<b>All models</b>		Control terminal block	4.5	28–12 (Sol) AWG 30–12 (Str) AWG

**Notes:** ① IP20 FR0 will be available in June 2018.

② The line and motor wire size for DG1-32088xx-xxxx/DH1-320114xx-xxxx can only be 1/0 AWG.

## Appendix D—Safety instructions for UL and cUL

- For 575 V Drive Series, required line and motor wire torque, type and size range are listed in **Table 84**

**Table 84. Required line and motor wire torque (575 V)**

DG1 catalog number	DH1 catalog number	Terminal type	Required torque (in-lb)	Required wire range
<b>FR1</b>				
DG1-353D3xx-xxxx	DH1-354D5XX-XXXX	L1, L2, L3, DC+, DC-, R+, R-, U, V, W	5.3	14–10 AWG
DG1-354D5xx-xxxx	DH1-357D5XX-XXXX		5.3	14–10 AWG
DG1-357D5xx-xxxx	DH1-35010XX-XXXX		5.3	14–10 AWG
<b>FR2</b>				
DG1-35010xx-xxxx	DH1-35013XX-XXXX	L1, L2, L3, DC+, DC-, R+, R-, U, V, W	15.6	12–6 AWG
DG1-35013xx-xxxx	DH1-35018XX-XXXX		15.6	10–6 AWG
DG1-35018xx-xxxx	DH1-35022XX-XXXX		15.6	10–6 AWG
<b>FR3</b>				
DG1-35022xx-xxxx	DH1-35027XX-XXXX	L1, L2, L3, DC+, DC-, R+, R-, U, V, W	40	6–2 AWG
DG1-35027xx-xxxx	DH1-35034XX-XXXX		40	6–2 AWG
DG1-35034xx-xxxx	DH1-35041XX-XXXX		40	6–2 AWG
<b>FR4</b>				
DG1-35041xx-xxxx	DH1-35052XX-XXXX	L1, L2, L3, DC+, DC-, R+, R-, U, V, W	95	4–1/0 AWG
DG1-35052xx-xxxx	DH1-35062XX-XXXX		95	4–1/0 AWG
DG1-35062xx-xxxx	DH1-35080XX-XXXX		95	2–1/0 AWG
<b>FR5</b>				
DG1-35080xx-xxxx	DH1-35100XX-XXXX	L1, L2, L3, DC+, DC-, R+, R-, U, V, W	354	1/0 AWG–350 kcmil
DG1-35100xx-xxxx	DH1-35125XX-XXXX		354	2/0 AWG–350 kcmil
DG1-35125xx-xxxx	DH1-35144XX-XXXX		354	3/0 AWG–350 kcmil
<b>FR6</b>				
DG1-35144xx-xxxx	DH1-35208XX-XXXX	L1, L2, L3, DC+, DC-, R+, R-, U, V, W	480	2*(1/0–300 kcmil)
DG1-35208xx-xxxx	DH1-35250XX-XXXX		480	2*(2/0–300 kcmil)
<b>All Frame Sizes (FR1–FR6)</b>				
<b>All models</b>		Control Terminal Block	4.5	28–12 (Sol) AWG, 30–12 (Str) AWG

## Grounding

- For 480 V Drive Series, required grounding wire torque, type and size range are listed in **Table 85**

**Table 85. Required grounding wire torque (480 V)**

DG1 catalog number	DH1 catalog number	Terminal type	Required torque (in-lb)	Required wire range
<b>FR0</b>				
DG1-342D2EB-C20C	DH1-343D3EB-C20C ①	Grounding terminal	14	14–10 AWG
DG1-343D3EB-C20C	DH1-344D3EB-C20C ①		14	14–10 AWG
DG1-344D3EB-C20C	DH1-345D6EB-C20C ①		14	14–10 AWG
DG1-345D6EB-C20C	DH1-347D6EB-C20C ①		14	14–10 AWG
<b>FR1</b>				
DG1-342D2xx-xxxx	DH1-343D3XX-XXXX	Grounding terminal	10	14–10 AWG
DG1-343D3xx-xxxx	DH1-344D3XX-XXXX		10	14–10 AWG
DG1-344D3xx-xxxx	DH1-345D6XX-XXXX		10	14–10 AWG
DG1-345D6xx-xxxx	DH1-347D6XX-XXXX		10	14–10 AWG
DG1-347D6xx-xxxx	DH1-349D0XX-XXXX		10	14–10 AWG
DG1-349D0xx-xxxx	DH1-34012XX-XXXX		10	14–10 AWG
<b>FR2</b>				
DG1-34012xx-xxxx	DH1-34016XX-XXXX	Grounding terminal	10	12–6 AWG
DG1-34016xx-xxxx	DH1-34023XX-XXXX		10	10–6 AWG
DG1-34023xx-xxxx	DH1-34031XX-XXXX		10	8–6 AWG
<b>FR3</b>				
DG1-34031xx-xxxx	DH1-34038XX-XXXX	Grounding terminal	10	8–4 AWG
DG1-34038xx-xxxx	DH1-34046XX-XXXX		10	8–4 AWG
DG1-34046xx-xxxx	DH1-34061XX-XXXX		10	6–4 AWG
<b>FR4</b>				
DG1-34061xx-xxxx	DH1-34072XX-XXXX	Grounding terminal	14	4–1/0 AWG
DG1-34072xx-xxxx	DH1-34087XX-XXXX		14	4–1/0 AWG
DG1-34087xx-xxxx	DH1-34105XX-XXXX		14	3–1/0 AWG
<b>FR5</b>				
DG1-34105xx-xxxx	DH1-34140XX-XXXX	Grounding terminal	35	3 AWG–250 kcmil
DG1-34140xx-xxxx	DH1-34170XX-XXXX		35	3 AWG–250 kcmil
DG1-34170xx-xxxx	DH1-34205XX-XXXX		35	3 AWG–250 kcmil
<b>FR6</b>				
DG1-34205xx-xxxx	DH1-34261XX-XXXX	Grounding terminal	35	3–300 kcmil
DG1-34245xx-xxxx	DH1-34310XX-XXXX		35	3–300 kcmil

**Note:** ① IP20 FR0 will be available in June 2018.

## Appendix D—Safety instructions for UL and cUL

- For 230 V Drive Series, required grounding wire torque, type and size range are listed in **Table 86**

**Table 86. Required grounding wire torque (230 V)**

DG1 catalog number	DH1 catalog number	Terminal type	Required torque (in-lb)	Required wire range
<b>FR0</b>				
DG1-323D7EB-C20C	DH1-324D8EB-C20C ①	Grounding terminal	14	14–10 AWG
DG1-324D8EB-C20C	DH1-326D6EB-C20C ①		14	14–10 AWG
DG1-326D6EB-C20C	DH1-327D8EB-C20C ①		14	14–10 AWG
<b>FR1</b>				
DG1-323D7xx-xxxx	DH1-324D8XX-XXXX	Grounding terminal	10	14–10 AWG
DG1-324D8xx-xxxx	DH1-326D6XX-XXXX		10	14–10 AWG
DG1-326D6xx-xxxx	DH1-327D8XX-XXXX		10	14–10 AWG
DG1-327D8xx-xxxx	DH1-32011XX-XXXX		10	14–10 AWG
DG1-32011xx-xxxx	DH1-32012XX-XXXX		10	12–10 AWG
<b>FR2</b>				
DG1-32012xx-xxxx	DH1-32017XX-XXXX	Grounding terminal	10	10–6 AWG
DG1-32017xx-xxxx	DH1-32025XX-XXXX		10	10–6 AWG
DG1-32025xx-xxxx	DH1-32031XX-XXXX		10	10–6 AWG
<b>FR3</b>				
DG1-32031xx-xxxx	DH1-32048XX-XXXX	Grounding terminal	10	6–4 AWG
DG1-32048xx-xxxx	DH1-32061XX-XXXX		10	6–4 AWG
<b>FR4</b>				
DG1-32061xx-xxxx	DH1-32075XX-XXXX	Grounding terminal	14	4–1/0 AWG
DG1-32075xx-xxxx	DH1-32088XX-XXXX		14	4–1/0 AWG
DG1-32088xx-xxxx	DH1-32114XX-XXXX		14	3–1/0 AWG
<b>FR5</b>				
DG1-32114xx-xxxx	DH1-32143XX-XXXX	Grounding terminal	35	3 AWG–250 kcmil
DG1-32143xx-xxxx	DH1-32170XX-XXXX		35	3 AWG–250 kcmil
DG1-32170xx-xxxx	DH1-32211XX-XXXX		35	3 AWG–250 kcmil
<b>FR6</b>				
DG1-32211xx-xxxx	DH1-32261XX-XXXX	Grounding terminal	35	3–300 kcmil
DG1-32248xx-xxxx	DH1-32312XX-XXXX		35	3–300 kcmil

**Note:** ① IP20 FR0 will be available in June 2018.

- For 575 V Drive Series, required grounding wire torque, type and size range are listed in **Table 87**

**Table 87. Required grounding wire torque (575 V)**

DG1 catalog number	DH1 catalog number	Terminal type	Required torque (in-lb)	Required wire range
<b>FR1</b>				
DG1-353D3xx-xxxx	DH1-354D5XX-XXXX	Grounding terminal	10	14–10
DG1-354D5xx-xxxx	DH1-357D5XX-XXXX		10	12–10
DG1-357D5xx-xxxx	DH1-35010XX-XXXX		10	10
<b>FR2</b>				
DG1-35010xx-xxxx	DH1-35013XX-XXXX	Grounding terminal	10	10–6
DG1-35013xx-xxxx	DH1-35018XX-XXXX		10	10–6
DG1-35018xx-xxxx	DH1-35022XX-XXXX		10	8–6
<b>FR3</b>				
DG1-35022xx-xxxx	DH1-35027XX-XXXX	Grounding terminal	10	8–4
DG1-35027xx-xxxx	DH1-35034XX-XXXX		10	8–4
DG1-35034xx-xxxx	DH1-35041XX-XXXX		10	6–4
<b>FR4</b>				
DG1-35041xx-xxxx	DH1-35052XX-XXXX	Grounding terminal	14	6–1/0
DG1-35052xx-xxxx	DH1-35062XX-XXXX		14	6–1/0
DG1-35062xx-xxxx	DH1-35080XX-XXXX		14	4–1/0
<b>FR5</b>				
DG1-35080xx-xxxx	DH1-35100XX-XXXX	Grounding terminal	35	4 AWG–250 kcmil
DG1-35100xx-xxxx	DH1-35125XX-XXXX		35	4 AWG–250 kcmil
DG1-35125xx-xxxx	DH1-35144XX-XXXX		35	4 AWG–250 kcmil
<b>FR6</b>				
DG1-35144xx-xxxx	DH1-35208XX-XXXX	Grounding terminal	35	3–300 kcmil
DG1-35208xx-xxxx	DH1-35250XX-XXXX		35	3–300 kcmil

## Appendix E—STO function

### Description of safety function

#### Safety function and safe state

The STO (Safe Torque Off) function of PowerXL Series AC drive is implemented only by hardware and no software is involved to perform the STO function.

The STO function is available for operator to turn off the motor torque. It is intended to be used in the safety-related applications up to SIL 1 / SIL CL 1 acc. to IEC 61800-5-2, IEC 61508 and IEC 62061, and up to Cat. 1 / PL c acc. to ISO 13849-1.

#### Safety function

The power that can cause rotation (or motion in the case of a linear motor) shall be switched off from the motor when demanded.

#### Safe state

The safe state is when the power supply of the motor is switched off.

#### System response time

The time from when the operator presses the emergency stop button to when the motor power supply switch is turned off is  $\leq 1$  ms.

**Table 88. Safety-related parameters**

Operation mode	FR0	FR1-FR6
Operation mode	High demand	High demand
Safety integrity level	SIL 1 / SIL CL 1	SIL 1 / SIL CL 1
Systematic capability	SC 1	SC 1
Safety architecture	1001	1001
Category	1	1
Performance level	c	c
HFT	0	0
SFF of each element	> 78%	> 60%
PFDAVG	5.07E-03 (at PTI=20 years, 5.07% of SIL1)	8.60E-03 (at PTI=20 years, 8.6% of SIL1)
PFH	5.79E-08 (0.58% of SIL1)	9.82E-08 (1% of SIL1)
MTTFd	1.00E+05 years (high)	1162 years (high)
Proof Test Interval (PTI)	20 years	20 years
MRT	0 hour	0 hour
MTTR	0 hour	0 hour
$\lambda$ (total failures)	—	944.04 FIT
$\lambda_s$ (safe failures)	—	845.25 FIT
$\lambda_{DD}$ (dangerous detected failures)	—	0.00 FIT
$\lambda_{DU}$ (dangerous undetected failures)	—	98.21 FIT

**Note:** 1 FIT =  $10^{-9}$ /h.

All the previously mentioned safety-related parameters are calculated based on the assumptions:

- Failure rate of each component is based on the Siemens SN29500 database
- Component failure rates are constant over the life of the device
- Operating at a maximum ambient temperature of 60 °C
- The equal distribution is used for the failure modes ratio of each component

### INFORMATION

The above mentioned parameters are calculated without considering failure rates of external devices e.g. buttons, power supply, etc.

### Safety architecture and reliability block diagram

**Figure 53. Functional block diagram**

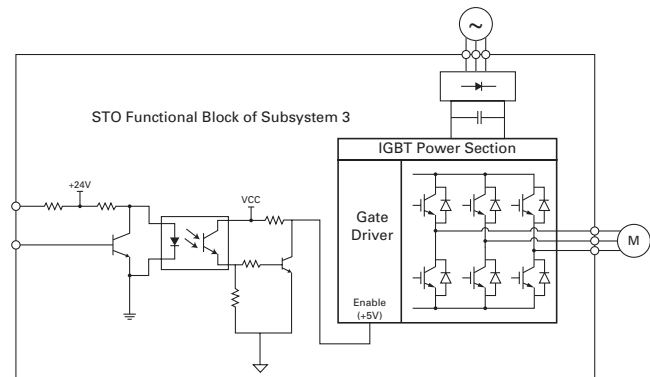

**Figure 54. Reliability block diagram**

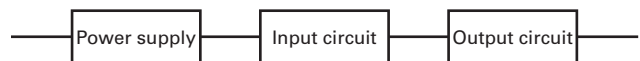

**Table 89. Power supply and input/output**

<b>Power supply</b>	230V series: 150–450 Vdc
	480V series: 300–900 Vdc
	575V series: 450–1100 Vdc
<b>Oversvoltage category</b>	III
<b>STO input signal voltage without demand</b>	5 Vdc ~ 18 Vdc
<b>STO input signal voltage when demand</b>	< 0.55 Vdc



**Table 90. Environmental and EMC conditions**

<b>Environmental</b>	
Ambient Operating Temperature	14 °F (–10 °C), no frost (down to –25 °C) +40 °C IL (110% OL for 1 Min) +50 °C IH (150% OL for 1 min) De-rating up to 55 °C, up to 60 °C with additional measures (e.g., removal of cover)
Storage Temperature	–40 °F (–40 °C) to 158 °F (70 °C)
Relative Humidity	0 to 95% RH, noncondensing, non-corrosive, no dripping water
Air Quality	Chemical vapors: EN60721-3-3, unit in operation, class 3C2; Mechanical particles: EN60721-3-3, unit in operation, class 3S2
Altitude	230 V and 480 V 100% load capacity (no de-rating) up to 3280 ft (1000 m); 1% de-rating for each 328 ft (100 m) above 3280 ft (1000 m); Max. 9842 ft (3000 m) Corner grounded TN (In a TN earthing system, one of the points in the generator or transformer is connected with earth, usually the star point in a three-phase system. The body of the electrical device is connected with earth via this earth connection at the transformer.) system and IT system up to 6561 ft (2000 m) maximum.  575 V 100% load capacity (no de-rating) up to 3280 ft (1000 m); 1% de-rating for each 328 ft (100 m) above 3280 ft (1000 m); Max. 6561 ft (2000 m)
Vibration	IEC/EN 61800-5-1, EN 60068-2-6; 3 to 150 Hz, Displacement amplitude 1 mm (peak) at 3 to 15.8 Hz, Max. acceleration amplitude 1G at 15.8 to 150 Hz (in package)
Shock	IEC/EN 61800-5-1, EN 60068-2-27 UPS Drop test (for applicable UPS weights) Storage and shipping: max. 15G, 11 ms (in package)
Enclosure Class	FR0: Open Type/IP20 FR1–FR6: NEMA Type 1/IP21 NEMA Type 12/IP54
<b>EMC</b>	
Immunity	EN/IEC 61800-3:2004+A1:2012, 2nd environment EN/IEC 61326-3-1:2017, 2nd environment
Radiated Emissions	EN/IEC 61800-3:2004+A1:2012 (Transient Testing included), 1st environment
Conducted emissions	EN/IEC 61800-3:2004+A1:2012 — Category C1: must be possible with external filter to drive (This is not part of the Project. When external filters are used, the internal ones have to be disabled to avoid resonances) — Category C2: with internal filter minimum of 10 m motor cable length — Category C3: with internal filter minimum of 50 m motor cable length
IEC/EN 61000-3-2 and IEC/EN 61000-3-12 for harmonics (with external measures)	
The change to EMC protection class will be done by removing built-in jumper, which will disconnect ground path	

**Applicable standards****IEC 61800-5-2:2016**Adjustable speed electrical power drive systems  
Part 5-2: Safety requirements—functional**IEC 61800-5-1:2007** (as far as applicable)Adjustable speed electrical power drive systems  
Part 5-1: Safety requirements—electrical, thermal and energy**IEC 61800-3:2017** (as far as applicable)Adjustable speed electrical power drive systems  
Part 3: EMC requirements and specific test methods**IEC 61326-3-1:2017**Electrical equipment for measurement, control and laboratory use—  
EMC requirementsPart 3-1: Immunity requirements for safety-related systems and for equipment intended to perform safety-related functions (functional safety)—  
general industrial applications**IEC 62061:2015**Safety of machinery—functional safety of safety-related electrical,  
electronic and programmable electronic control systems**ISO 13849-1:2015**Safety of machinery—Safety Related Parts of Control Systems  
Part 1: General principles for design**IEC 61508, parts 1–7:2010**Functional safety of electrical/electronic/programmable electronic  
safety-related systems

**Requirement for installation, commission, maintenance**

A two-pin terminal block in control board (STO in **Figure 55**) is used for customer to connect emergency stop switch, safety relay or PLC, and so on.

**Figure 55. STO terminal block in PowerXL control board**

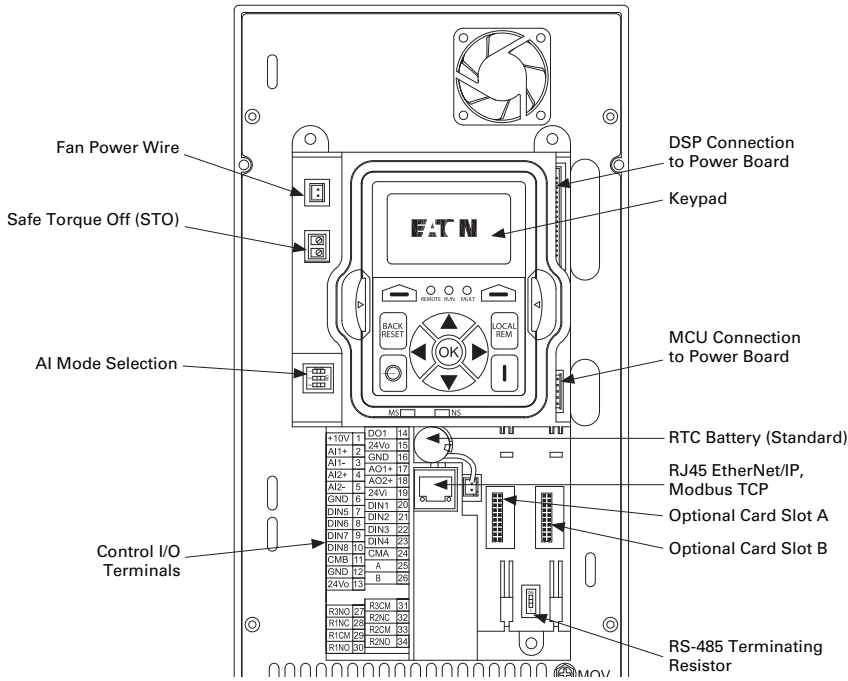

The STO terminal block shall be short circuited by jumper if user doesn't needed STO function.

If the function is used by customer, the STO terminal block shall be connected to emergency stop switch, safety relay or PLC, and so on.

The STO function needs to be always on, which means the idle-current principle shall be followed by the end user.

**Figure 56. Thermistor STO wiring diagram**

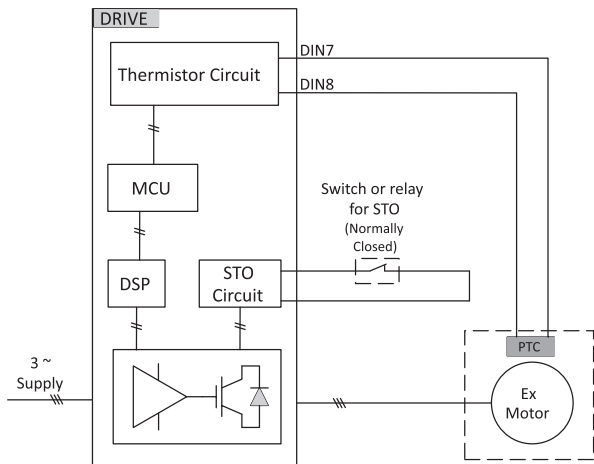

**Requirements of proof test**

- This device must be subjected to a full test at least once every 20 years
- The STO function must be verified
- The system response time must be verified to check whether it is still  $\leq 1\text{ms}$

**Note for EC Type-Examination Certificate**

Only below models meet MD/LVD/EMC requirements and apply for the STO EC Type-Examination Certificate, all other models apply for the STO Certificate without EC Type-Examination:

- DG1 Series: DG1-32xxxEB-C20C, DG1-32xxxFx-xxxx  
DG1-34xxxEB-C20C, DG1-34xxxFx-xxxx
- DH1 Series: DH1-32xxxEB-C20C, DH1-32xxxFx-xxxx  
DH1-34xxxEB-C20C, DH1-34xxxFx-xxxx

## Appendix F—UL certificate of compliance

### UL certificate of compliance

Certificate Number: E134360

Report Reference: E354803

Issued to: Eaton Corp

In accordance with UL 508C, Power Conversion Equipment and CSA C22.2 No. 274-13 and CSA C22.2 No. 274-17, Adjustable Speed Drives. See UL report for additional details.

### CE declaration of conformance

In accordance with the following standards:

2014/35/EU Low Voltage Directive

2014/30/EU EMC Directive

2011/65/EU RoHS Directive

based on compliance with European standard(s):

EN 61800-5-1:2007

EN 61800-3:2004 + A1:2012

EN 50581:2012

Visit [www.eaton.com/dg1](http://www.eaton.com/dg1) > Documentation > Certifications for additional details.

Visit [www.eaton.com/dh1](http://www.eaton.com/dh1) > Documentation > Certifications for additional details.



**Eaton**  
1000 Eaton Boulevard  
Cleveland, OH 44122  
United States  
Eaton.com

© 2019 Eaton  
All Rights Reserved  
Printed in USA  
Publication No. MN0400002EN / Z23435  
December 2019

Eaton is a registered trademark.

All trademarks are property  
of their respective owners.