

PowerXL DG1 Series VFD

Instruction Leaflet
Montageanweisung
Notice d'installation
Instrucciones de montaje
Istruzioni per il montaggio
安装说明

Инструкция по монтажу
Montagehandleiding
Montagevejledning
Οδηγίες εγκατάστασης
Instruções de montagem
Monteringsanvisning

Asennusohje
Návod k montáži
Paigaldusjuhend
Szerelési utasítás
Montážas instrukcija
Montavimo instrukcija

Instrukcja montażu
Navodila za montažo
Návod na montáž
Μονταžни инструкции
Instruções de montaj



(en) **Electric Current! Danger to Life!**

Only skilled or instructed persons may carry out the following operations.

(de) **Lebensgefahr durch elektrischen Strom!**

Nur Elektrofachkräfte und elektrotechnisch unterwiesene Personen dürfen die im Folgenden beschriebenen Arbeiten ausführen.

(fr) **Tension électrique dangereuse !**

Seules les personnes qualifiées et averties doivent exécuter les travaux ci-après.

(es) **¡Corriente eléctrica! ¡Peligro de muerte!**

El trabajo a continuación descrito debe ser realizado por personas cualificadas y advertidas.

(it) **Tensione elettrica: Pericolo di morte!**

Solo persone abilitate e qualificate possono eseguire le operazioni di seguito riportate.

(zh) **触电危险!**

只允许专业人员和受过专业训练的人员进行下列工作。

(ru) **Электрический ток! Опасно для жизни!**

Только специалисты или проинструктированные лица могут выполнять следующие операции.

(nl) **Levensgevaar door elektrische stroom!**

Uitsluitend deskundigen in elektriciteit en elektrotechnisch geïnstrueerde personen is het toegestaan, de navolgend beschrevene werkzaamheden uit te voeren.

(da) **Livsfare på grund af elektrisk strøm!**

Kun uddannede el-installatører og personer der er instruerede i elektrotekniske arbejdsopgaver, må udføre de nedenfor anførte arbejder.

(el) **Προσοχή, κίνδυνος ηλεκτροπληξίας!**

Οι εργασίες που αναφέρονται στη συνέχεια θα πρέπει να εκτελούνται μόνο από ηλεκτρολόγους και ηλεκροτεχνίτες.

(pt) **Perigo de vida devido a corrente eléctrica!**

Apenas electricistas e pessoas com formação electrotécnica podem executar os trabalhos que a seguir se descrevem.

(sv) **Livsfara genom elektrisk ström!**

Endast utbildade elektriker och personer som undervisats i elektroteknik får utföra de arbeten som beskrivs nedan.

(fi) **Hengenvaarallinen jännite!**

Vain pätevät sähköasentajat ja opastusta saaneet henkilöt saavat suorittaa seuraavat työt.

EAT•N

Powering Business Worldwide

Effective November 2017

CS Nebezpečí úrazu elektrickým proudem!

Níže uvedené práce směřjí provádět pouze osoby s elektrotechnickým vzděláním.

et Eluohhtlik! Elektrilöögioht!

Järgnevalt kirjeldatud töid tohib teostada ainult elektriala spetsialist või elektrotehnilise instrueerimise läbinud personal.

hu Életveszély az elektromos áram révén!

Csak elektromos szakemberek és elektrotechnikában képzett személyek végezhetik el a következőkben leírt munkákat.

lv Elektriskā strāva apdraud dzīvību!

Tālāk aprakstītos darbus drīkst veikt tikai elektrospeciālisti un darbam ar elektrotehniskām ekārtām instruetās personas!

lt Pavojus gyvybei dėl elektros srovės!

Tik elektrikai ir elektrotechnikos specialistai gali atlikti žemiau aprašytus darbus.

pl Porażenie prądem elektrycznym stanowi zagrożenie dla życia!

Opisane poniżej prace mogą przeprowadzać tylko wykwalifikowani elektrycy oraz osoby odpowiednio poinstruowane w zakresie elektrotechniki.

sl Življenjska nevarnost zaradi električnega toka!

Spodaj opisana dela smejo izvajati samo elektrostrokovnjaki in elektrotehnično poučene osebe.

sk Nebezpečenstvo ohrozenia života elektrickým prúdom!

Práce, ktoré sú nižšie opísané, smú vykonávať iba elektroodborníci a osoby s elektrotechnickým vzdelaním.

bg Опасност за живота от електрически ток!

Операциите, описани в следващите раздели, могат да се извършват само от специалисти-електротехници и инструктиран електротехнически персонал.

ro Atenție! Pericol electric!

Toate lucrările descrise trebuie efectuate numai de personal de specialitate calificat și de persoane cu cunoștințe profunde în electrotehnică.

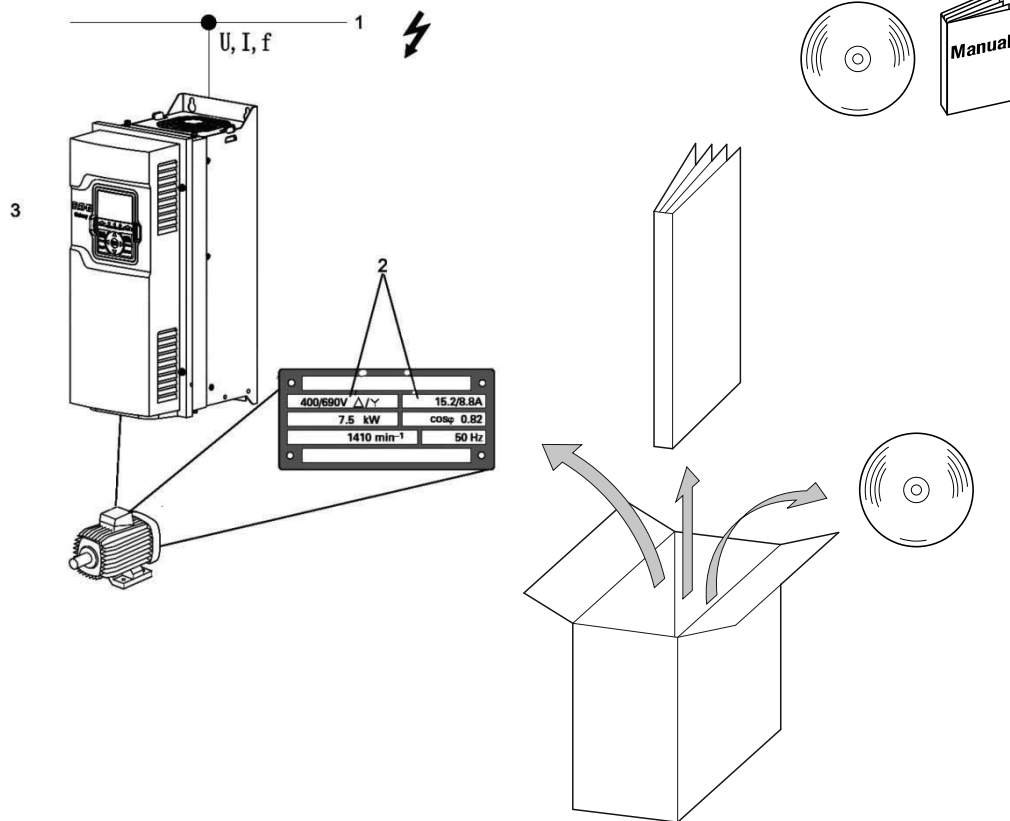

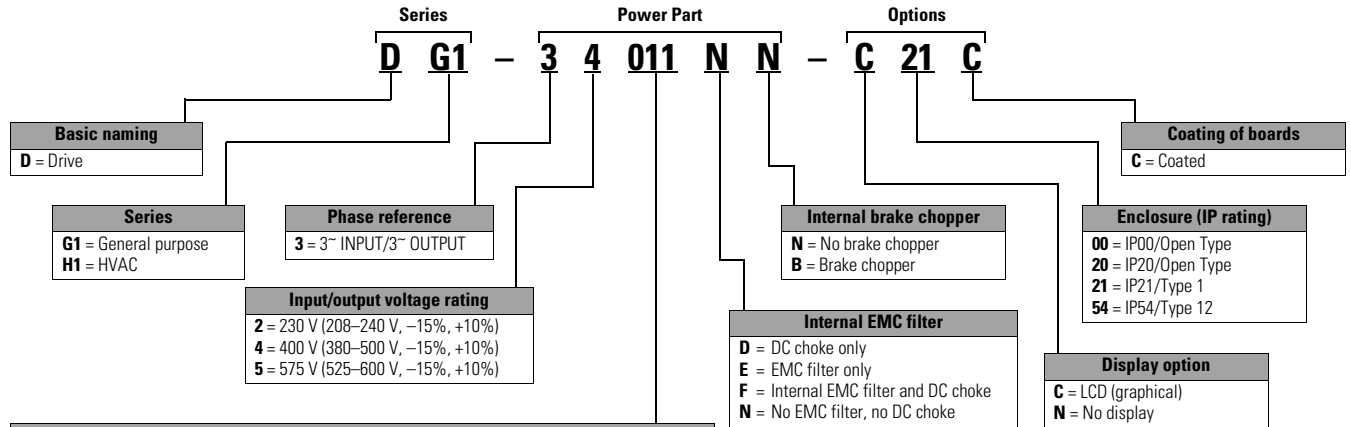

DG1—Output current rating (CT)		
208–240 V	380–500 V	525–600 V
3D7 = 3.7 A, 0.55 kW, 0.75 hp	2D2 = 2.2 A, 0.75 kW, 1 hp	3D3 = 3.3 A, 1.5 kW, 2 hp
4D8 = 4.8 A, 0.75 kW, 1 hp	3D3 = 3.3 A, 1.1 kW, 1.5 hp	4D5 = 4.5 A, 2.2 kW, 3 hp
6D6 = 6.6 A, 1.1 kW, 1.5 hp	4D3 = 4.3 A, 1.5 kW, 2 hp	7D5 = 7.5 A, 3.7 kW, 5 hp
7D8 = 7.8 A, 1.5 kW, 2 hp	5D6 = 5.6 A, 2.2 kW, 3 hp	010 = 10 A, 5.5 kW, 7.5 hp
011 = 11 A, 2.2 kW, 3 hp	7D6 = 7.6 A, 3 kW, 5 hp	013 = 13.5 A, 7.5 kW, 10 hp
012 = 12.5 A, 3 kW, 5 hp (VT)	9D0 = 9 A, 4 kW, 7.5 hp (VT)	018 = 18 A, 11 kW, 15 hp
017 = 17.5 A, 3.7 kW, 5 hp	012 = 12 A, 5.5 kW, 7.5 hp	022 = 22 A, 15 kW, 20 hp
025 = 25 A, 5.5 kW, 7.5 hp	016 = 16 A, 7.5 kW, 10 hp	027 = 27 A, 18.5 kW, 25 hp
031 = 31 A, 7.5 kW, 10 hp	023 = 23 A, 11 kW, 15 hp	034 = 34 A, 22 kW, 30 hp
048 = 48 A, 11 kW, 15 hp	031 = 31 A, 15 kW, 20 hp	041 = 41 A, 30 kW, 40 hp
061 = 61 A, 15 kW, 20 hp	038 = 38 A, 18.5 kW, 25 hp	052 = 52 A, 37 kW, 50 hp
075 = 75 A, 18.5 kW, 25 hp	046 = 46 A, 22 kW, 30 hp	062 = 62 A, 45 kW, 60 hp
088 = 88 A, 22 kW, 30 hp	061 = 61 A, 30 kW, 40 hp	080 = 80 A, 55 kW, 75 hp
114 = 114 A, 30 kW, 40 hp	072 = 72 A, 37 kW, 50 hp	100 = 100 A, 75 kW, 100 hp
143 = 143 A, 37 kW, 50 hp	087 = 87 A, 45 kW, 60 hp	125 = 125 A, 90 kW, 125 hp
170 = 170 A, 45 kW, 60 hp	105 = 105 A, 55 kW, 75 hp	144 = 144 A, 110 kW, 150 hp
211 = 211 A, 55 kW, 75 hp	140 = 140 A, 75 kW, 100 hp	208 = 208 A, 132 kW, 200 hp
248 = 248 A, 75 kW, 100 hp	170 = 170 A, 90 kW, 125 hp	
	205 = 205 A, 110 kW, 150 hp	
	245 = 245 A, 132 kW, 200 hp	

Dimensions and weights—Dimensões e pesos—Encombremets et poids—Abmessungen und Gewichte—Dimensioni e pesi—Afmetingen en gewichten—Dimensioner og vægt—Διαστάσεις και βάρη—Dimensiones y pesos—Mått och vikter—Mitat ja painot—Rozměry a hmotnosti—Mõõdud ja kaalud—Méretek és tömeg—Izmēri un svars—Matmenys ir masē—Wymiary i ciężary—Mere in teže—Rozměry a hmotnosti—Размеры и тепло—Dimensiuni și greutateți—Размеры и вес—尺寸和重量

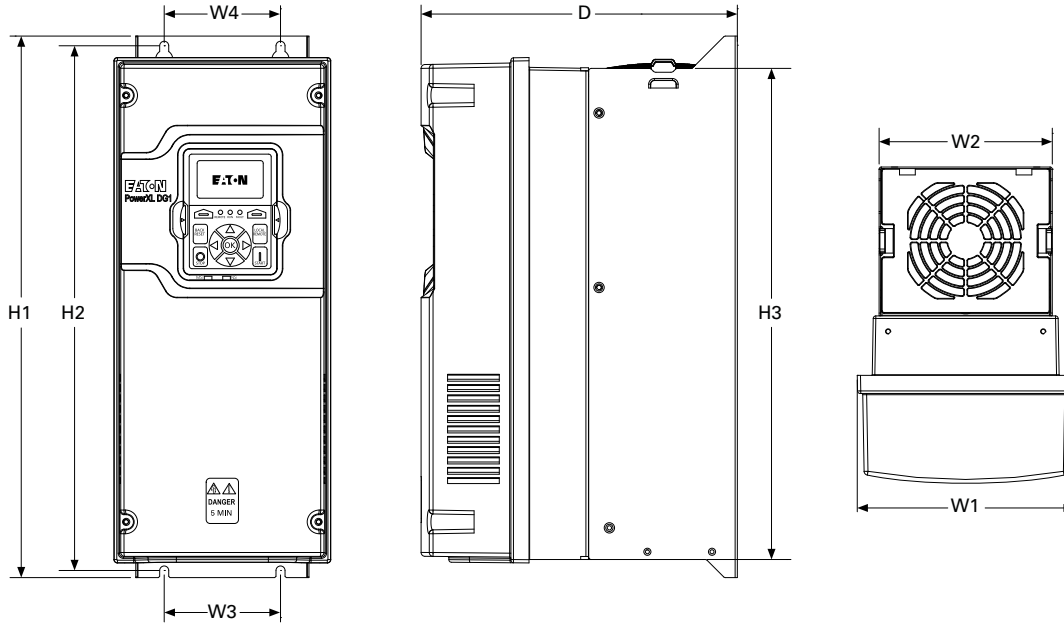

Frame size	Approximate dimensions in inches (mm)									Weight lb (kg)
	D	H1	H2	H3	W1	W2	W3	W4	Ø	
FR0	6.83 (173.5)	10.58 (268.7)	10.16 (258.0)	9.54 (242.3)	5.00 (127.0)	4.97 (126.3)	4.26 (108.3)	4.26 (108.3)	0.28 (7.0)	4.41 (2.0)
FR1	7.91 (200.9)	12.87 (327.0)	12.28 (312.0)	11.50 (292.0)	6.02 (153.0)	4.80 (122.0)	3.94 (100.0)	3.94 (100.0)	0.28 (7.0)	14.33 (6.5)
FR2	9.63 (244.7)	16.50 (419.0)	15.98 (406.0)	14.96 (380.0)	6.61 (167.8)	5.28 (134.0)	3.54 (90.0)	3.54 (90.0)	0.28 (7.0)	23.37 (10.6)
FR3	10.44 (265.1)	21.97 (558.0)	21.46 (545.0)	20.41 (518.5)	8.06 (204.6)	7.24 (184.0)	4.92 (125.0)	4.92 (125.0)	0.35 (9.0)	49.82 (22.6)
FR4	11.57 (294.0)	24.80 (630.0)	24.31 (617.5)	23.26 (590.7)	9.36 (237.7)	9.13 (232.0)	8.07 (205.0)	8.07 (205.0)	0.35 (9.0)	77.60 (35.2)
FR5	13.41 (340.7)	34.98 (888.5)	29.65 (753.0)	27.83 (707.0)	11.34 (288.0)	11.10 (282.0)	8.66 (220.0)	8.66 (220.0)	0.35 (9.0)	154.32 (70.0)
FR6	14.61 (371.1)	40.75 (1035.1)	33.27 (845.1)	31.38 (797.1)	19.13 (485.9)	18.90 (480.1)	15.75 (400.1)	15.75 (400.1)	0.35 (9.0)	246.91 (112.0)

**Mounting – Montaje – Montage – Montaggio – Monterig – Τοποθέτηση – Montagem – Asennus –
 Montáž – Paigaldamine – Felszerelés – Montáža – Montavimas – Montaż – Montaža – Монтаж –
 Montarea – Монтаж – 安装**

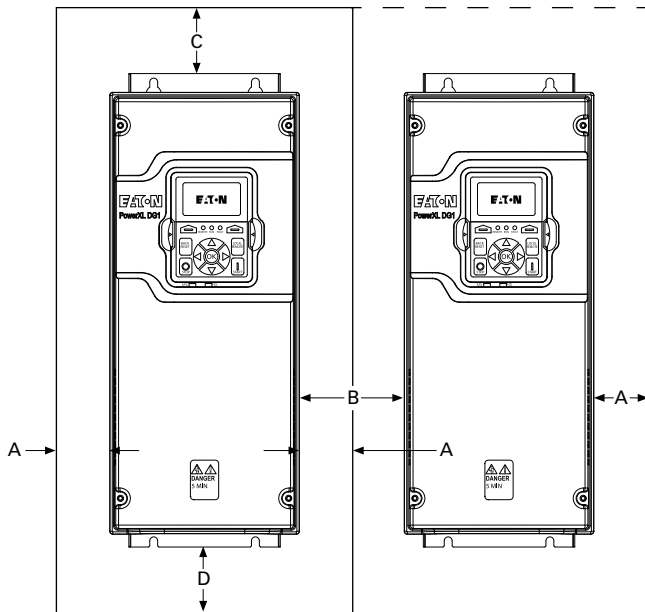

Frame size	A ^② In (mm)	B ^② In (mm)	C In (mm)	D In (mm)	Cooling air required CFM (m ³ /h) ^③
FR0	0	0	3.94 (100)	1.97 (50)	16.5 (28)
FR1	0.79 (20)	1.58 (40)	3.94 (100)	1.97 (50)	14 (24)
FR2	1.18 (30)	2.36 (60)	6.30 (160)	2.36 (60)	55 (94)
FR3	0	0	7.87 (200)	3.15 (80)	85 (144)
FR4	0	0	11.81 (300)	3.94 (100)	153 (260)
FR5	3.15 (80)	6.30 (160)	11.81 (300)	7.87 (200)	232 (395)
FR6	0	0	15.75 (400)	12.99 (330)	230 V: 435 (739) 460 V/600 V: 400 (679)

Notes

- ① kW ratings are at 400 V / 50 Hz.
- ② Minimum clearances A and B for drives with Type 12 (IP54) enclosure is 0 mm (in) for FR1, FR2, FR3, FR4, FR6.
- ③ The above guidelines apply unless testing has been completed to validate a design outside of these recommendations.

FR0 mounting instructions

Step 1:

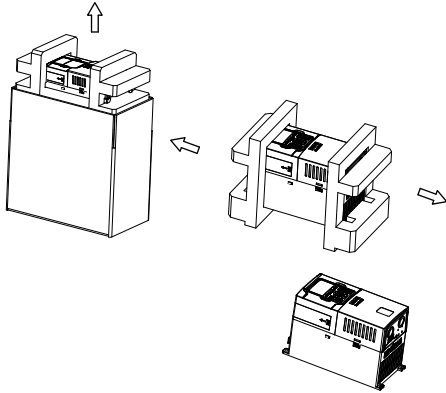

Step 2:

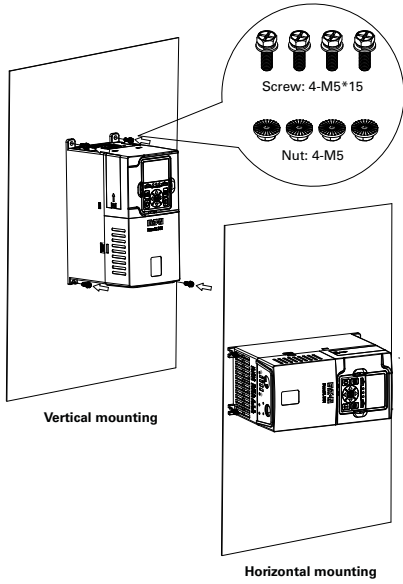

FR1 mounting instructions

Step 1:

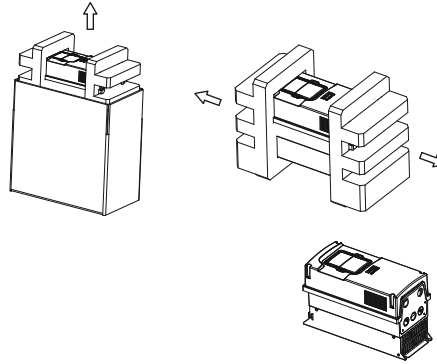

Step 2:

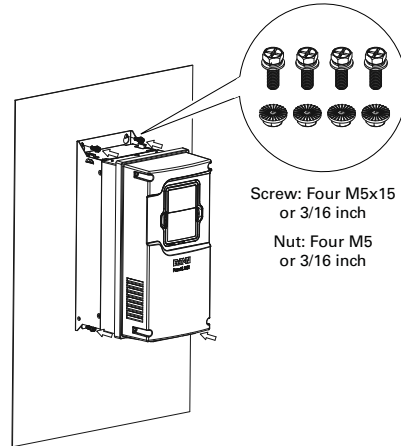

Step 3:

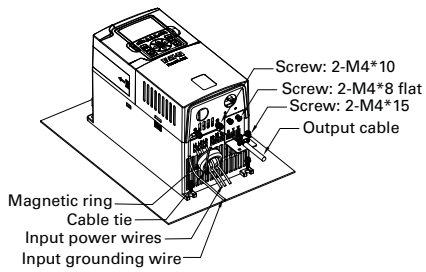

FR2 mounting instructions

Step 1:

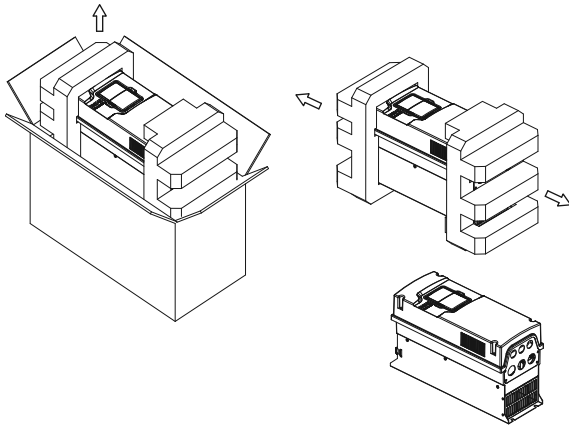

Step 2:

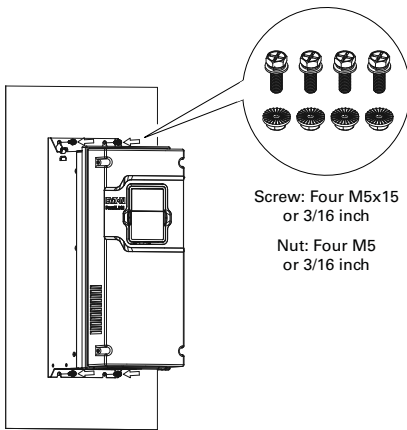

FR3 mounting instructions

Step 1:

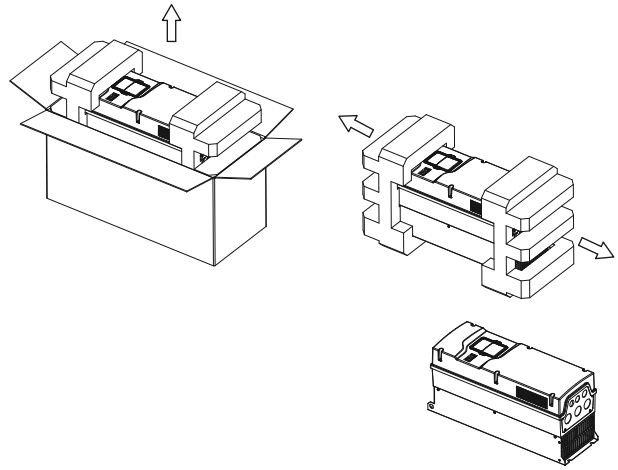

Step 2:

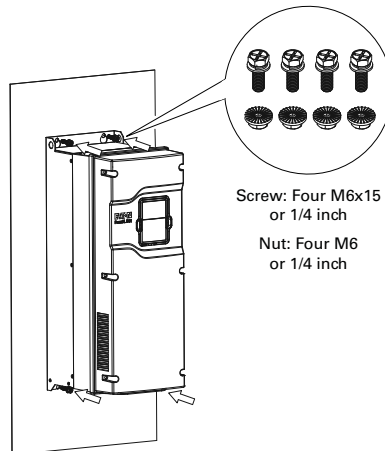

FR4 mounting instructions

Step 1:

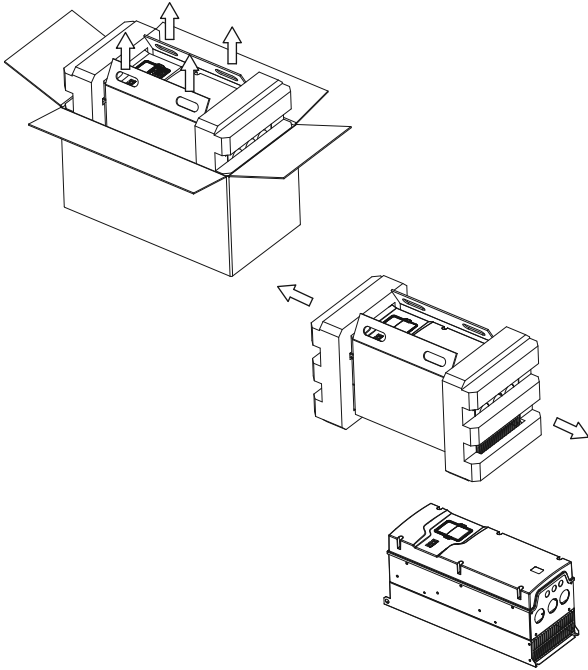

Step 2:

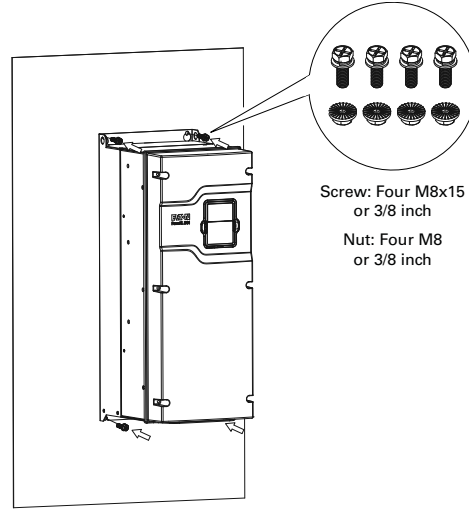

FR5 mounting instructions

Step 1:

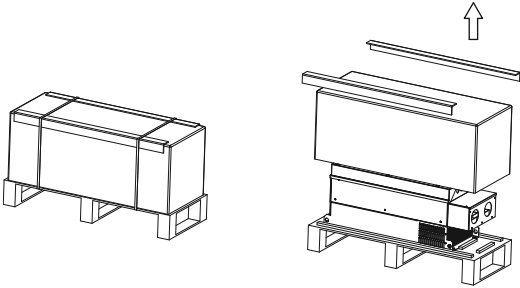

Step 2:

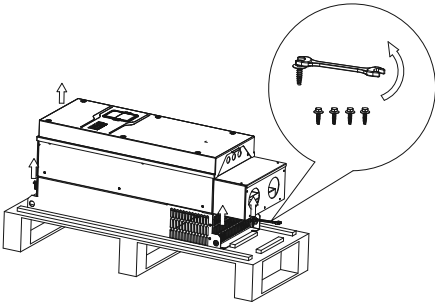

Step 3:

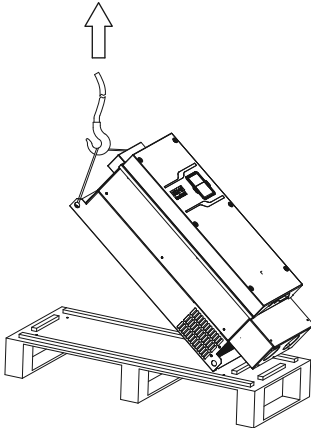

Step 4:

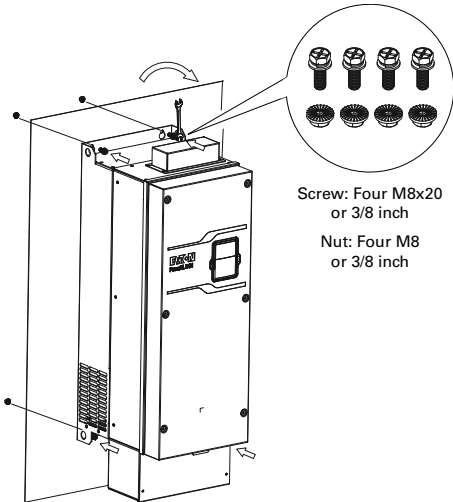

FR6 mounting instructions

Step 1: Remove the carton from the drive.

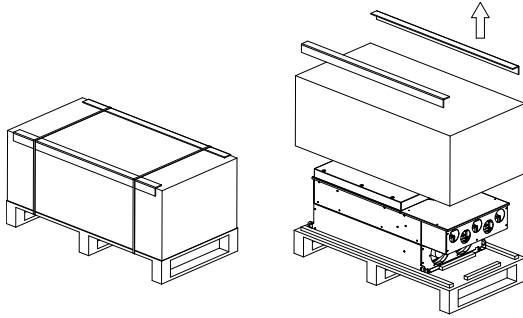

Step 2: Remove the four screws (used to fix the drive to the pallet) with an M8 or 3/8-inch wrench.

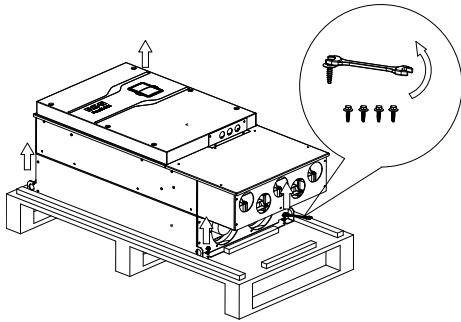

Step 4: Attach the drive to the mounting plate with four M8x20 or 3/8-inch screws and four M8 or 3/8-inch nuts with an M8 or 2/8-inch wrench. The opening dimensions on the mounting plate should follow required dimensions (refer to the drive mounting template printed on the outside carton).

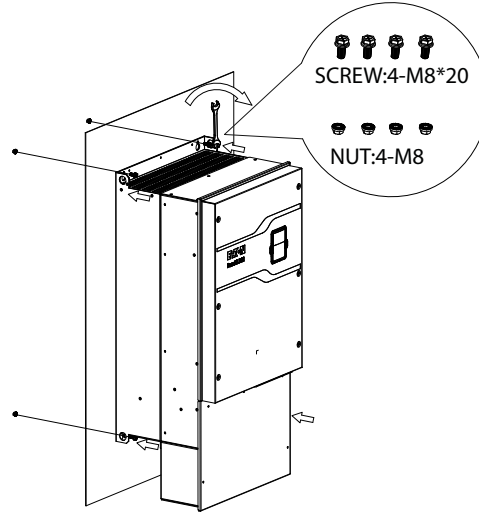

Step 3: Use a hook to lift the drive.

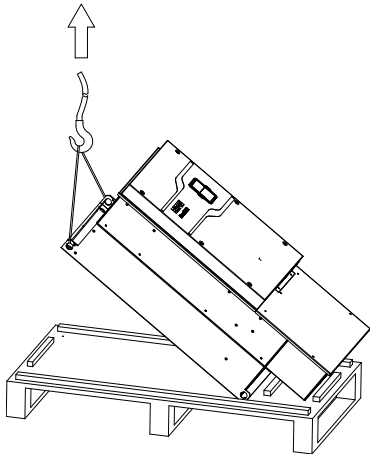



(en)

Warning!

Connect only in voltage-free state!

(es)

¡Advertencia!

¡Conectar únicamente en estado sin tensión!

(fr)

Avertissement !

Raccordez l'appareil uniquement hors tension !

(de)

Warnung!

Nur im spannungsfreien Zustand anschließen!

(it)

Avvertimento!

Collegare solo in assenza di tensione!

(nl)

Waarschuwing!

Alleen in spanningsloze toestand aansluiten!

(da)

Advarsel!

Må kun tilsluttes i spændingsfri tilstand!

(el)

Προειδοποίηση!

Συνδέστε μόνο όταν δεν επικρατεί τάση!

(pt)

Atenção!

Ligar apenas com a tensão desligada!

(sv)

Varning!

Får endast anslutas i spänningsfritt tillstånd!

(fi)

Varoitus!

Kytke vain jännitteettömässä tilassa!

(cs)

Varování!

Připojujte jen při zcela odpojeném napájení!

(et)

Hoiatus!

Ühendada ainult pingevabas olekus!

(hu)

Figyelmeztetés!

Csak feszültségmentes állapotban csatlakoztassa!

(lv)

Bīdinājums!

Pieslēgt tikai tad, kad nenotiek sprieguma padeve!

(lt)

Perspėjimas!

Prijungti tik tada, kai išjungta įtampa!

(pl)

Ostrzeżenie!

Podłączać zawsze po uprzednim odłączeniu od zasilania elektrycznego!

(sl)

Opozorilo!

Napravo priključite le, ko ni pod napetostjo!

(sk)

Varovanie!

Napájak len v stave bez napätia!

(bg)

Предупреждение!

Свързвайте само, когато уреда не е под напрежение!

(ro)

Atenție!

Conectați doar când aparatul nu se află sub tensiune!

(ru)

Предупреждение!

Подключать только в обесточенном состоянии!

(zh)

警告!

必须在断电状态下进行连接!

Ground wiring

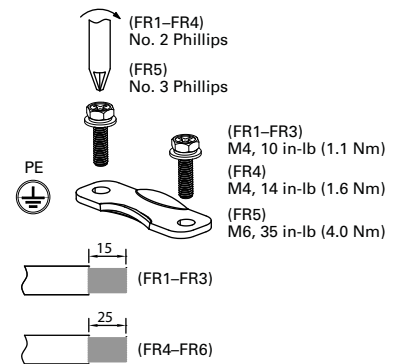
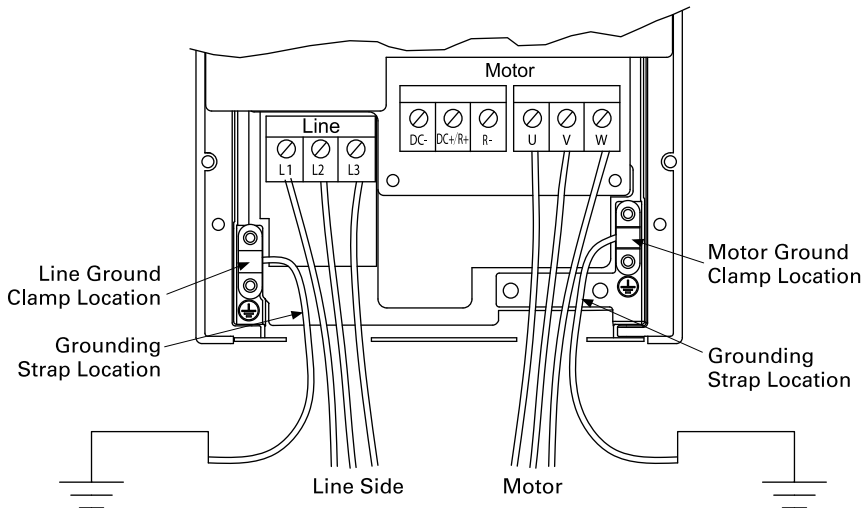

Ground wiring—FR0

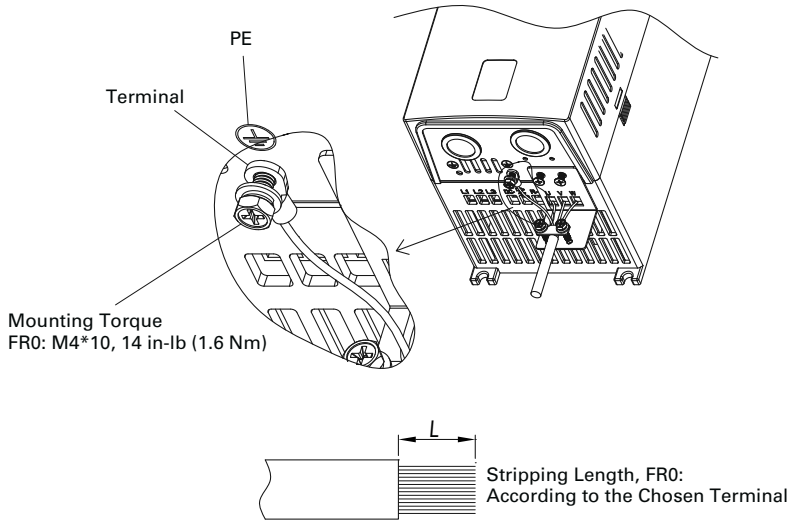

Rubber grommet installation instructions

Step 1:

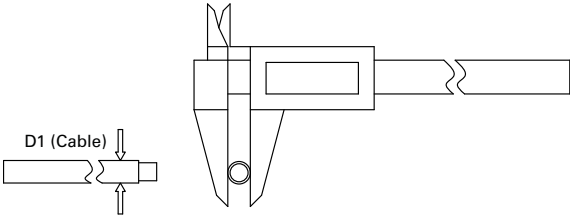

Step 2:

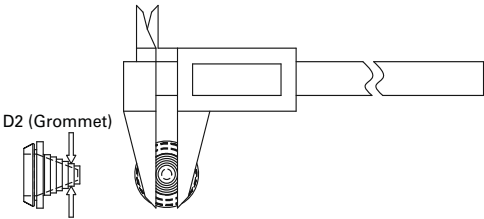

Step 3:

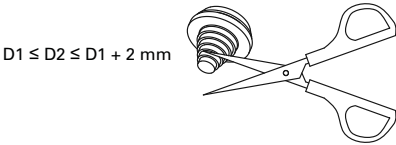

Step 4:

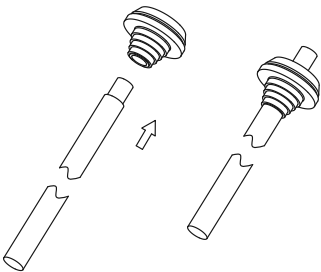

Step 5:

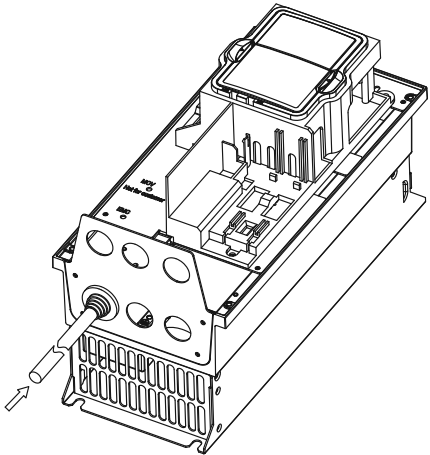

Step 6:

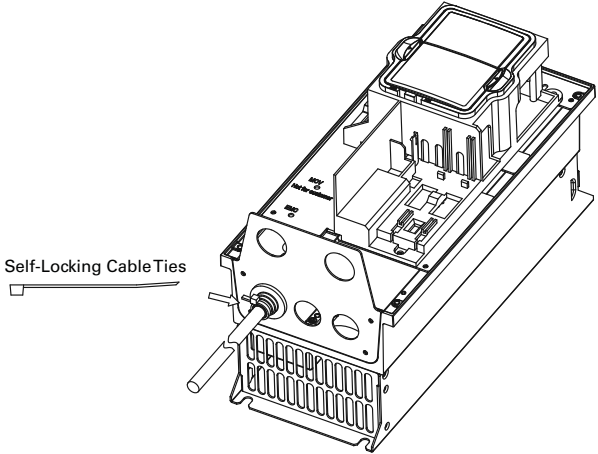

Input power and motor cable stripping lengths

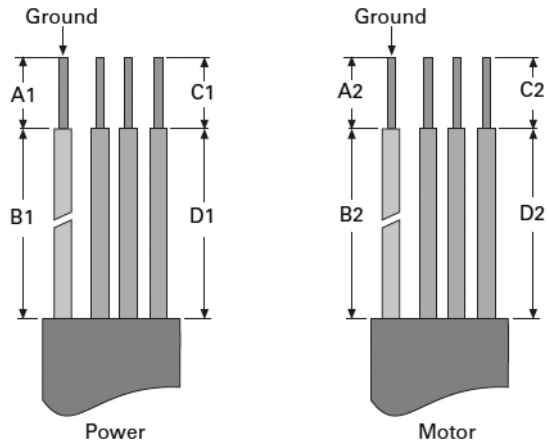

Frame size	Power wiring in inches (mm)				Motor wiring in inches (mm)			
	A1	B1	C1	D1	A2	B2	C2	D2
FR0	0.39 (10)	5.12 (130)	0.39 (10)	5.12 (130)	0.39 (10)	3.15 (80)	0.39 (10)	1.97 (50)
FR1	0.39 (10)	1.77 (45)	0.39 (10)	1.38 (35)	0.39 (10)	1.77 (45)	0.39 (10)	1.38 (35)
FR2	0.59 (15)	1.77 (45)	0.59 (15)	1.77 (45)	0.59 (15)	1.57 (40)	0.59 (15)	1.57 (40)
FR3	0.59 (15)	1.57 (40)	0.59 (15)	1.97 (50)	0.59 (15)	1.57 (40)	0.59 (15)	1.97 (50)
FR4	0.98 (25)	2.56 (65)	0.98 (25)	4.72 (120)	0.98 (25)	2.56 (65)	0.98 (25)	4.72 (120)
FR5	1.10 (28)	6.10 (155)	1.10 (28)	9.45 (240)	1.10 (28)	6.10 (155)	1.10 (28)	9.45 (240)
FR6	0.98 (25)	4.72 (120)	0.98 (25)	7.87 (200)	0.98 (25)	4.72 (120)	0.98 (25)	7.87 (200)

Power connection tightening torque ^{①②}

Frame size	Power wire in-lb (Nm)	Ground wire in-lb (Nm)	Control wire in-lb (Nm) ^③
FR0	5.3 (0.6)	14 (1.6)	4.5 (0.5)
FR1	5.3 (0.6)	10 (1.1)	4.5 (0.5)
FR2	15.6 (1.8)	10 (1.1)	4.5 (0.5)
FR3	40 (4.5)	10 (1.1)	4.5 (0.5)
FR4	95 (10.7)	14 (1.6)	4.5 (0.5)
FR5	354 (40.0)	35 (4.0)	4.5 (0.5)
FR6	480 (54.2)	35 (4.0)	4.5 (0.5)

Notes

- ① Strip the motor and power cables as shown above.
- ② Both UL[®] and IEC tools may be used.
- ③ Applies to strained wire, solid wire, or ferrule installations.

Cable and fuse guidelines

North America cable and fuse sizes—208 Vac to 240 Vac ratings ^{①②}

Frame size	Amp suffix		208 V input current		NEC motor amp rating		Current (CT/I _H) (VT/I _L)		Recommended fuse rating ^③	NEC [®] wire size (AWG)		Terminal connection size (AWG)	
	(CT/I _H)	(VT/I _L)	(CT/I _H)	(VT/I _L)	at 230 V	at 208 V	at 50 °C	at 40 °C		Line and motor	Ground	Line and motor	Ground
FR0	3D7	4D8	4.3	5.6	4.2	4.6	3.7	4.8	10	14	14	26–10	18–10
	4D8	6D6	5.6	7.6	6	6.6	4.8	6.6	10	14	14	26–10	18–10
	6D6	7D8	7.6	9	6.8	7.5	6.6	7.8	15	14	14	26–10	18–10
FR1	3D7	4D8	3.2	4.4	4.2	4.6	3.7	4.8	10	14	14	24–10	18–10
	4D8	6D6	4.4	6.1	6	6.6	4.8	6.6	10	14	14	24–10	18–10
	6D6	7D8	6.1	7.2	6.8	7.5	6.6	7.8	10	14	14	24–10	18–10
	7D8	011	7.2	10.2	9.6	10.6	7.8	11	15	14	14	24–10	18–10
	011	012	10.2	11.6	—	—	11	12.5	15	12	12	24–10	18–10
FR2	012	017	10.2	16.3	15.2	16.7	12.5	17.5	20	10	10	20–6	12–6
	017	025	16.2	23.2	22	24.2	17.5	25	30	8	10	20–6	12–6
	025	031	23.1	29	28	30.8	25	31	35	8	10	20–6	12–6
FR3	031	048	28.7	44.2	42	46.2	31	48	60	6	6	6–2	14–4
	048	061	44.4	56	54	59.4	48	61	80	4	6	6–2	14–4
FR4	061	075	56.4	64.6	68	74.8	61	75	100	3	4	6–1/0	10–1/0
	075	088	69.4	78	80	88	75	88	110	2	4	6–1/0	10–1/0
	088	114	81.4	94.3	104	114	88	114	125	1/0	3	6–1/0	10–1/0
FR5	114	143	105.5	129	130	143	114	143	175	3/0	3	1/0–350 kcmil	8–250 kcmil
	143	170	132.3	157	154	169	143	170	200	4/0	3	1/0–350 kcmil	8–250 kcmil
	170	211	157.3	189	192	211	170	211	250	300	3	1/0–350 kcmil	8–250 kcmil
FR6	211	248	196.3	242.8	248	273	211	261	400	2*2/0	3	2* (1/0–300 kcmil)	3–300 kcmil
	248	312	230.7	290.3	312	343	248	312	400	2*4/0	3	2* (1/0–300 kcmil)	3–300 kcmil

Notes

^① Line and motor cable size is selected according to UL 508C Table 40.3 for copper conductor rated 75 °C. Use only with copper wire rated 75 °C here.

Size requirements for other different wire types are defined in the National Electrical Code[®], ANSI/NFPA[®] 70.

^② Earthing conductor size is determined by the maximum overcurrent device rating used ahead of the drive according to UL 508C Table 6.4.

^③ If power cubes or bypass are used, a UL listed Class RK5, J, T or equivalent fuse is recommended.

Effective November 2017

International cable and fuse sizes—208 Vac to 240 Vac ratings ^{①②}

Frame size	Amp suffix		208 V input current		Current (CT/I _H)		Fuse rating (gG/gL) ^③	Mains and motor cable Cu (mm ²)	Terminal cable size	
	(CT/I _H)	(VT/I _L)	(CT/I _H)	(VT/I _L)	at 50 °C	at 40 °C			Main terminal Cu (mm ²)	Earth terminal Cu (mm ²)
FR0	3D7	4D8	4.3	5.6	3.7	4.8	10	3*1.5+1.5	0.2–6 solid or 0.2–4 stranded	0.75–6
	4D8	6D6	5.6	7.6	4.8	6.6	10	3*1.5+1.5	0.2–6 solid or 0.2–4 stranded	0.75–6
	6D6	7D8	7.6	9	6.6	7.8	16	3*1.5+1.5	0.2–6 solid or 0.2–4 stranded	0.75–6
FR1	3D7	4D8	3.2	4.4	3.7	4.8	6	3*1.5+1.5	0.2–6 solid or 0.2–4 stranded	0.75–6
	4D8	6D6	4.4	6.1	4.8	6.6	10	3*1.5+1.5	0.2–6 solid or 0.2–4 stranded	0.75–6
	6D6	7D8	6.1	7.2	6.6	7.8	16	3*1.5+1.5	0.2–6 solid or 0.2–4 stranded	0.75–6
	7D8	011	7.2	10.2	7.8	11	16	3*1.5+1.5	0.2–6 solid or 0.2–4 stranded	0.75–6
	011	012	10.2	11.6	11	12.5	16	3*1.5+1.5	0.2–6 solid or 0.2–4 stranded	0.75–6
FR2	012	017	10.2	16.3	12.5	17.5	20	3*4+4	0.5–16	4–16
	017	025	16.2	23.2	17.5	25	32	3*4+4	0.5–16	4–16
	025	031	23.1	29	25	31	32	3*6+6	0.5–16	4–16
FR3	031	048	28.7	44.2	31	48	50	3*16+16	16–35	2.5–25
	048	061	44.4	56	48	61	63	3*16+16	16–35	2.5–25
FR4	061	075	56.4	64.6	61	75	80	3*25+16	16–50	6–50
	075	088	69.4	78	75	88	100	3*35+16	16–50	6–50
	088	114	81.4	94.3	88	114	125	3*50+25	16–50	6–50
FR5	114	143	105.5	129	114	143	160	3*70+35	50–185	10–120
	143	170	132.3	157	143	170	200	3*95+50	50–185	10–120
	170	211	157.3	189	170	211	250	3*150+95	50–185	10–120
FR6	211	248	196.3	242.8	211	261	400	2*(3*70+35)	2*(50–150)	35–150
	248	312	230.7	290.3	248	312	400	2*(3*95+50)	2*(50–150)	35–150

Notes

- ① Line and motor cable size is selected according to IEC 60364-5-52:2009 Table B.52.4 for copper conductor with PVC insulation with a wiring condition of ambient temperature 30 °C in air and an installation method of "B2" (cables in conduit and cable trunking systems). For other wiring conditions, please refer to the standard of IEC 60364-5-52:2009 for suitable cable sizes.
- ② Earthing conductor size is determined by the cross-sectional area of phase conductors according to IEC/EN 61800-5-1:2007 Table 5. So if phase conductor size is changed, earthing conductor size should also be changed accordingly.
- ③ If power cubes or bypass are used, a Class gG/gL fuse is recommended.

North America cable and fuse sizes—440 Vac to 500 Vac ratings ^{①②}

Frame size	Amp suffix		208 V input current		NEC motor amp rating at 460 V	Current (CT/I _H) (VT/I _L)		Recommended fuse rating ^③	NEC [®] wire size (AWG)		Terminal connection size (AWG)	
	(CT/I _H)	(VT/I _L)	(CT/I _H)	(VT/I _L)		at 50 °C	at 40 °C		Line and motor	Ground	Line and motor	Ground
FR0	2D2	3D3	2.6	3.8	3	2.1	3	10	14	14	26–10	18–10
	3D3	4D3	3.8	4.3	3.4	3	3.4	10	14	14	26–10	18–10
	4D3	5D6	4.3	6	4.8	3.4	4.8	10	14	14	26–10	18–10
	5D6	7D6	6	9.6	7.6	4.8	7.6	15	14	14	26–10	18–10
FR1	2D2	3D3	2	2.8	3	2.1	3	10	14	14	26–10	18–10
	3D3	4D3	2.8	3.2	3.4	3	3.4	10	14	14	26–10	18–10
	4D3	5D6	3.2	4.5	4.8	3.4	4.8	10	14	14	26–10	18–10
	5D6	7D6	4.5	7.1	7.6	4.8	7.6	10	14	14	26–10	18–10
	7D6	9D0	7.1	8.4	—	7.6	7.6	15	14	14	26–10	18–10
	9D0	012	8.4	10.2	11	7.6	11	15	14	14	26–10	18–10
FR2	012	016	10.2	13	14	11	14	20	12	12	20–6	12–6
	016	023	13	19.6	21	14	21	30	10	10	20–6	12–6
	023	031	19.5	25.2	27	21	27	35	8	8	20–6	12–6
FR3	031	038	25.1	31.7	34	27	34	50	6	8	6–2	14–4
	038	046	31.6	37	40	34	40	60	6	8	6–2	14–4
	046	061	37.2	48.1	52	40	52	80	4	6	6–2	14–4
FR4	061	072	48.3	59.3	65	52	65	100	4	4	6–1/0	10–1/0
	072	087	60.4	70.3	77	65	77	110	3	4	6–1/0	10–1/0
	087	105	71.6	87.6	96	77	96	125	1	3	6–1/0	10–1/0
FR5	105	140	89.2	114.4	124	96	124	175	2/0	3	1/0–350 kcmil	8–250 kcmil
	140	170	115.3	144	156	124	156	200	3/0	3	1/0–350 kcmil	8–250 kcmil
	170	205	145	166.1	180	156	180	250	250 kcmil	3	1/0–350 kcmil	8–250 kcmil
FR6	205	245	169.8	226.4	240	180	240	400	2*2/0	3	2*(1/0–300 kcmil)	3–300 kcmil
	245	302	226.4	284.9	302	240	302	400	2*4/0	3	2*(1/0–300 kcmil)	3–300 kcmil

Notes

^① Line and motor cable size is selected according to UL 508C Table 40.3 for copper conductor rated 75 °C. Use only with copper wire rated 75 °C here.

Size requirements for other different wire types are defined in the National Electrical Code, ANSI/NFPA 70.

^② Earthing conductor size is determined by the maximum overcurrent device rating used ahead of the drive according to UL 508C Table 6.4.

^③ If power cubes or bypass are used, a UL listed Class RK5, J, T or equivalent fuse is recommended.

International cable and fuse sizes—380 Vac to 440 Vac ratings ^{①②}

Frame size	Amp suffix		400 V input current		Current (CT/I _H)		Fuse rating (gG/gL) ^③	Mains and motor cable Cu (mm ²)	Terminal cable size	
	(CT/I _H)	(VT/I _L)	(CT/I _H)	(VT/I _L)	at 50 °C	at 40 °C			Main terminal Cu (mm ²)	Earth terminal Cu (mm ²)
FR0	2D2	3D3	2.7	4.3	2.2	3.3	6	3*1.5+1.5	0.2–6 solid or 0.2–4 stranded	0.75–6
	3D3	4D3	4.3	5.5	3.3	4.3	10	3*1.5+1.5		0.75–6
	4D3	5D6	5.5	7.1	4.3	5.6	10	3*1.5+1.5	0.75–6	
	5D6	7D6	7.1	9.6	5.6	7.6	16	3*1.5+1.5	0.75–6	
FR1	2D2	3D3	2.0	3.1	2.2	3.3	6	3*1.5+1.5	0.2–6 solid or 0.2–4 stranded	0.75–6
	3D3	4D3	3.1	4	3.3	4.3	6	3*1.5+1.5		0.75–6
	4D3	5D6	4	5.2	4.3	5.6	10	3*1.5+1.5	0.75–6	
	5D6	7D6	5.2	7.1	5.6	7.6	16	3*1.5+1.5	0.75–6	
	7D6	9D0	7.1	8.4	7.6	9	16	3*1.5+1.5	0.75–6	
	9D0	012	8.4	11.2	9	12	16	3*1.5+1.5	0.75–6	
FR2	012	016	11.2	15	12	16	20	3*4+4	0.5–16	4–16
	016	023	14.9	21.5	16	23	25	3*4+4	0.5–16	4–16
	023	031	21.4	29	23	31	32	3*6+6	0.5–16	4–16
FR3	031	038	28.8	35.2	31	38	40	3*16+16	16–35	2.5–25
	038	046	35.3	42.6	38	46	50	3*16+16	16–35	2.5–25
	046	061	42.8	55.7	46	61	63	3*16+16	16–35	2.5–25
FR4	061	072	56.7	65.7	61	72	80	3*25+16	16–50	6–50
	072	087	66.9	79.4	72	87	100	3*35+16	16–50	6–50
	087	105	80.9	97	87	105	125	3*50+25	16–50	6–50
FR5	105	140	97.6	129	105	140	160	3*70+35	50–185	10–120
	140	170	130.1	157	140	170	200	3*95+50	50–185	10–120
	170	205	158.0	189	170	205	250	3*120+70	50–185	10–120
FR6	205	245	193.4	246.2	205	261	400	2*(3*70+35)	2*(50–150)	35–150
	245	302	231.1	292.4	245	310	400	2*(3*95+50)	2*(50–150)	35–150

Notes

- ① Line and motor cable size is selected according to IEC 60364-5-52:2009 Table B.52.4 for copper conductor with PVC insulation with a wiring condition of ambient temperature 30 °C in air and an installation method of "B2" (cables in conduit and cable trunking systems). For other wiring conditions, please refer to the standard of IEC 60364-5-52:2009 for suitable cable sizes.
- ② Earthing conductor size is determined by the cross-sectional area of phase conductors according to IEC/EN 61800-5-1:2007 Table 5. So if phase conductor size is changed, earthing conductor size should also be changed accordingly.
- ③ If power cubes or bypass are used, a Class gG/gL fuse is recommended.

North America cable and fuse sizes—525 Vac to 600 Vac ratings ^{①②}

Frame size	Amp suffix	575 V input current (CT/I _H)	575 V input current (VT/I _L)	NEC motor amp rating at 575 V	Current (CT/I _H) at 50 °C	Current (VT/I _L) at 40 °C	Recommended fuse rating ^③	NEC wire Size (AWG)		Terminal connection size (AWG)	
								Line and motor	Ground	Line and motor	Ground
FR1	3D3	3.1	4.2	3.9	3.3	4.5	10	14	14	26–10	18–10
	4D5	4.2	7	6.1	4.5	7.5	10	14	12	26–10	18–10
	7D5	7	9.3	9	7.5	10	15	14	10	26–10	18–10
FR2	010	9.3	12.5	11	10	13.5	20	12	10	20–6	12–6
	013	12.5	16.7	17	13.5	18	30	10	10	20–6	12–6
	018	16.7	20.4	22	18	22	35	10	8	20–6	12–6
FR3	022	20.4	25.2	27	22	27	40	6	8	6–2	14–4
	027	25.1	31.7	32	27	34	45	6	8	6–2	14–4
	034	31.6	38.2	41	34	41	50	6	6	6–2	14–4
FR4	041	38.1	48.1	52	41	52	70	4	6	6–1/0	10–1/0
	052	48.3	57.4	62	52	62	80	4	6	6–1/0	10–1/0
	062	57.6	73	77	62	80	125	2	4	6–1/0	10–1/0
FR5	080	74.4	91.3	99	80	100	150	1/0	4	1/0–350 kcmil	8–250 kcmil
	100	93	114.1	125	100	125	175	2/0	4	1/0–350 kcmil	8–250 kcmil
	125	116.2	132.9	144	125	144	200	3/0	4	1/0–350 kcmil	8–250 kcmil
FR6	144	140.4	202.8	192	144	208	400	2*1/0	3	2*(1/0–300 kcmil)	3–300 kcmil
	208	202.8	243.8	242	208	250	400	2*2/0	3	2*(1/0–300 kcmil)	3–300 kcmil

Notes

- ① Line and motor cable size is selected according to UL 508C Table 40.3 for copper conductor rated 75 °C. Use only with copper wire rated 75 °C here. Size requirements for other different wire types are defined in the National Electrical Code, ANSI/NFPA 70.
- ② Earthing conductor size is determined by the maximum overcurrent device rating used ahead of the drive according to UL 508C Table 6.4.
- ③ If power cubes or bypass are used, a UL listed Class RK5, J, T or equivalent fuse is recommended.

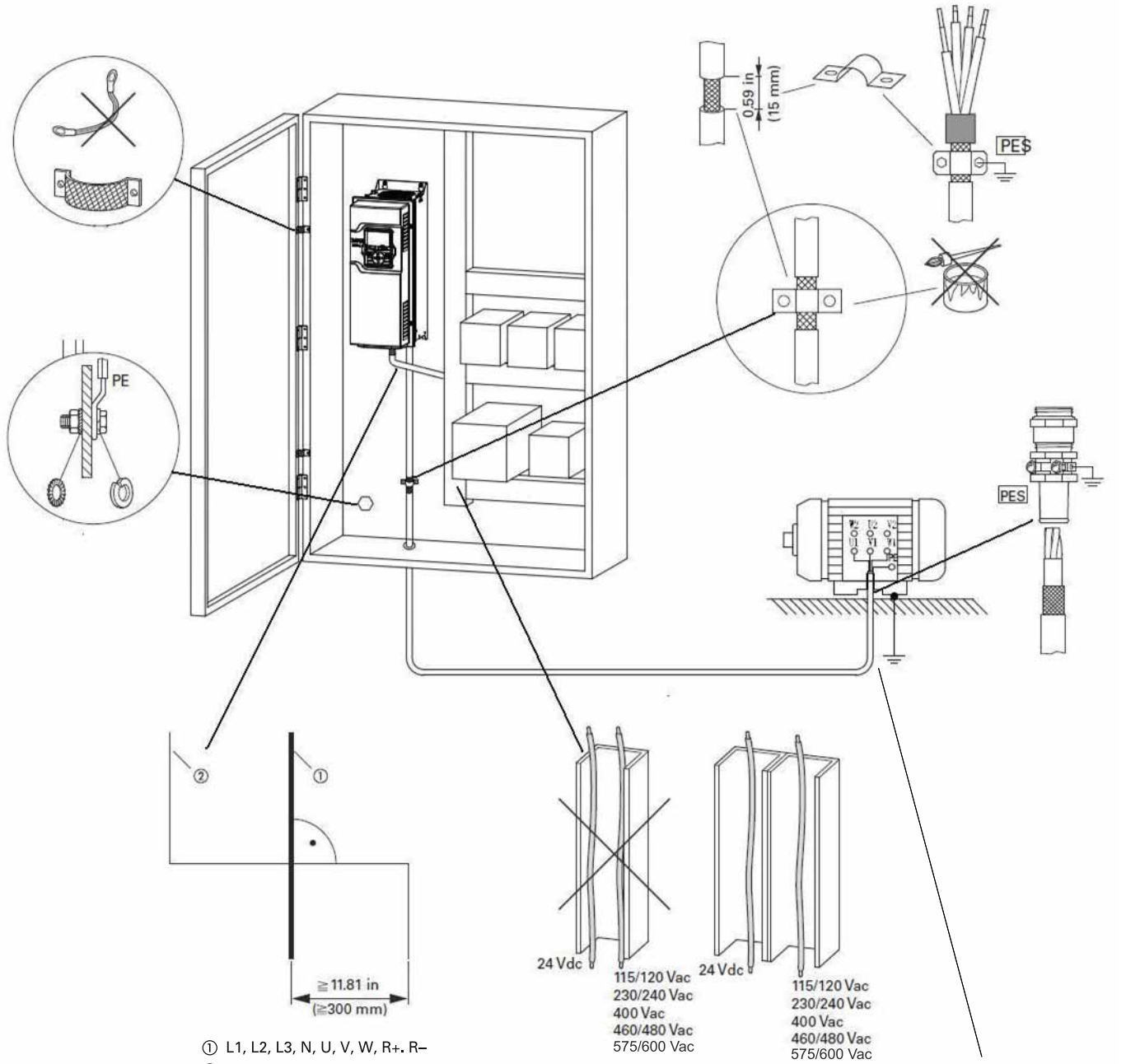

24 Vdc	115/120 Vac 230/240 Vac 400 Vac 460/480 Vac 575/600 Vac	24 Vdc	115/120 Vac 230/240 Vac 400 Vac 460/480 Vac 575/600 Vac
--------	---	--------	---

M-Max	Motor
U/T1U1	U/T1U1
V/T2V1	V/T2V1
W/T3W1	W/T3W1

400 Δ / 460 Y V	38 / 22 A
S1 11 kW	cos φ 0.67
1410 rpm	50 Hz

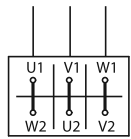
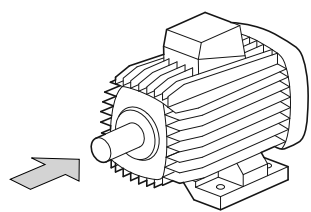

FWD

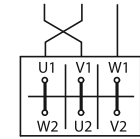

REV

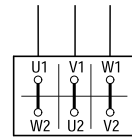

$U_{LN} = 230V$

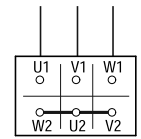

$(U_{LN} = 400V)$

Factory-set control terminal functions

I/O connection

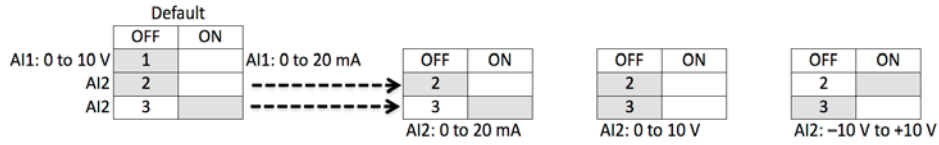

External wiring	Pin	Signal name	Signal	Default setting	Description
	1	+10 V	Ref. Output Voltage	—	10 Vdc Supply Source
	2	AI1+ ①	Analog Input 1	0–10 V	Voltage Speed Reference (Programmable to 4 mA to 20 mA)
	3	AI1–	Analog Input 1 Ground	—	Analog Input 1 Common (Ground)
	4	AI2+ ①	Analog Input 2	4 mA to 20 mA	Current Speed Reference (Programmable to 0–10 V)
	5	AI2–	Analog Input 2 Ground	—	Analog Input 2 Common (Ground)
	6	GND	I/O Signal Ground	—	I/O Ground for Reference and Control
	7	DIN5	Digital Input 5	Preset Speed B0	Sets frequency output to Preset Speed 1
	8	DIN6	Digital Input 6	Preset Speed B1	Sets frequency output to Preset Speed 2
	9	DIN7	Digital Input 7	Emergency Stop (TI–)	Input forces VFD output to shut off
	10	DIN8	Digital Input 8	Force Remote (TI+)	Input takes VFD from Local to Remote
	11	CMB	DI5 to DI8 Common	Grounded	Allows source input
	12	GND	I/O Signal Ground	—	I/O Ground for Reference and Control
	13	24 V	+24 Vdc Output	—	Control voltage output (100 mA max.)
	14	DO1	Digital Output 1	Ready	Shows the drive is ready to run
	15	24 Vo	+24 Vdc Output	—	Control voltage output (100 mA max.)
	16	GND	I/O Signal Ground	—	I/O Ground for Reference and Control
	17	A01+	Analog Output 1	Output Frequency	Shows Output frequency to motor 0–60 Hz (4 mA to 20 mA)
	18	A02+	Analog Output 2	Motor Current	Shows Motor current of motor 0–FLA (4 mA to 20 mA)
	19	24 Vi	+24 Vdc Input	—	External control voltage input
	20	DIN1	Digital Input 1	Run Forward	Input starts drive in forward direction (start enable)
	21	DIN2	Digital Input 2	Run Reverse	Input starts drive in reverse direction (start enable)
	22	DIN3	Digital Input 3	External Fault	Input causes drive to fault
	23	DIN4	Digital Input 4	Fault Reset	Input resets active faults
	24	CMA	DI1 to DI4 Common	Grounded	Allows source input
	25	A	RS-485 Signal A	—	Fieldbus Communication (Modbus, BACnet)
	26	B	RS-485 Signal B	—	Fieldbus Communication (Modbus, BACnet)
	27	R3NO	Relay 3 Normally Open	At Speed	Relay output 3 shows VFD is at Ref. Frequency
	28	R1NC	Relay 1 Normally Closed	Run	Relay output 1 shows VFD is in a run state
	29	R1CM	Relay 1 Common		
	30	R1NO	Relay 1 Normally Open		
	31	R3CM	Relay 3 Common	At Speed	Relay output 3 shows VFD is at Ref. Frequency
	32	R2NC	Relay 2 Normally Closed	Fault	Relay output 2 shows VFD is in a fault state
	33	R2CM	Relay 2 Common		
	34	R2NO	Relay 2 Normally Open		

Notes

The above wiring demonstrates a SINK configuration. It is important that CMA and CMB are wired to ground (as shown by dashed line). If a SOURCE configuration is desired, wire 24 V to CMA and CMB and close the inputs to ground. When using the +10 V for AI1, it is important to wire AI1– to ground (as shown by dashed line). If using +10 V for AI1 or AI2, terminals 3, 5, and 6 need to be jumpered together.

① AI1+ and AI2+ support 10K potentiometer.

接线图

PowerXL 系列—DG1 控制接线图

引脚	信号名称	信号	出厂默认值	产品描述
1	+10V	参考输出电压	-	10 Vdc 电源
2	AI1+	模拟输入1	0-10V	电压速度参考 (可编程为4-20mA)
3	AI1-	模拟输入1接地	-	模拟输入 通用 (接地)
4	AI2+	模拟输入2	4-20mA	电流速度参考 (可编程为0-10V)
5	AI2-	模拟输入2接地	-	模拟输入2 通用 (接地)
6	GND	I/O信号接地	-	I/O 接地, 用于参考和控制
7	DIN5	数字输入5	预设速度B0	设定频率输出至预设速度1
8	DIN6	数字输入6	预设速度B1	设定频率输出至预设速度2
9	DIN7	数字输入7	紧急停车	输入强制VFD输出关闭
10	DIN8	数字输入8	强制远程	输入将VFD从本地变为远程
11	CMB	DI5至DI8通用	已接地	允许电源输入
12	GND	I/O 信号接地	-	I/O接地, 用于参考和控制
13	24V	+24 Vdc 输出	-	控制电压输出 (最大值100mA)
14	DO1	数字输出1	准备就绪	显示变频器已准备好运行
15	24Vo	+24Vdc 输出	-	控制电源输出 (100mA)
16	GND	I/O信号接地	-	I/O接地, 用于参考和控制
17	AO1+	模拟输出1	输出频率	显示电机的输出频率 0-60Hz (4-20mA)
18	AO2+	模拟输出2	电机电流	显示电机的电机电流 0-FLA (4-20mA)
19	24Vi	+24VDC 输入	-	外部控制电压输入
20	DIN1	数字输入1	正向运行	输入以正向启动变频器 (启动启用)
21	DIN2	数字输入2	反向运行	输入以反向启动变频器 (启动启用)
22	DIN3	数字输入3	外部故障	输入造成变频器发生故障
23	DIN4	数字输入4	故障复位	输入复位有效故障
24	CMA	DI1至DI4通用	已接地	允许电源输入
25	A	RS-485 信号A	-	现场总线通讯 (Modbus, BACnet)
26	B	RS-485 信号B	-	现场总线通讯 (Modbus, BACnet)
27	R3NO	继电器3 常开	加速	继电器输出3显示VFD处于参考频率
28	R1NC	继电器1常闭	运行	继电器输出1显示VFD处于运行状态
29	R1CM	继电器1通用		
30	R1NO	继电器1常开		
31	R3CM	继电器3通用	加速	继电器输出3显示VFD处于参考频率
32	R2NC	继电器2常闭	故障	继电器输出2显示VFD处于故障状态
33	R2CM	继电器2通用		
34	R2NO	继电器2常开		

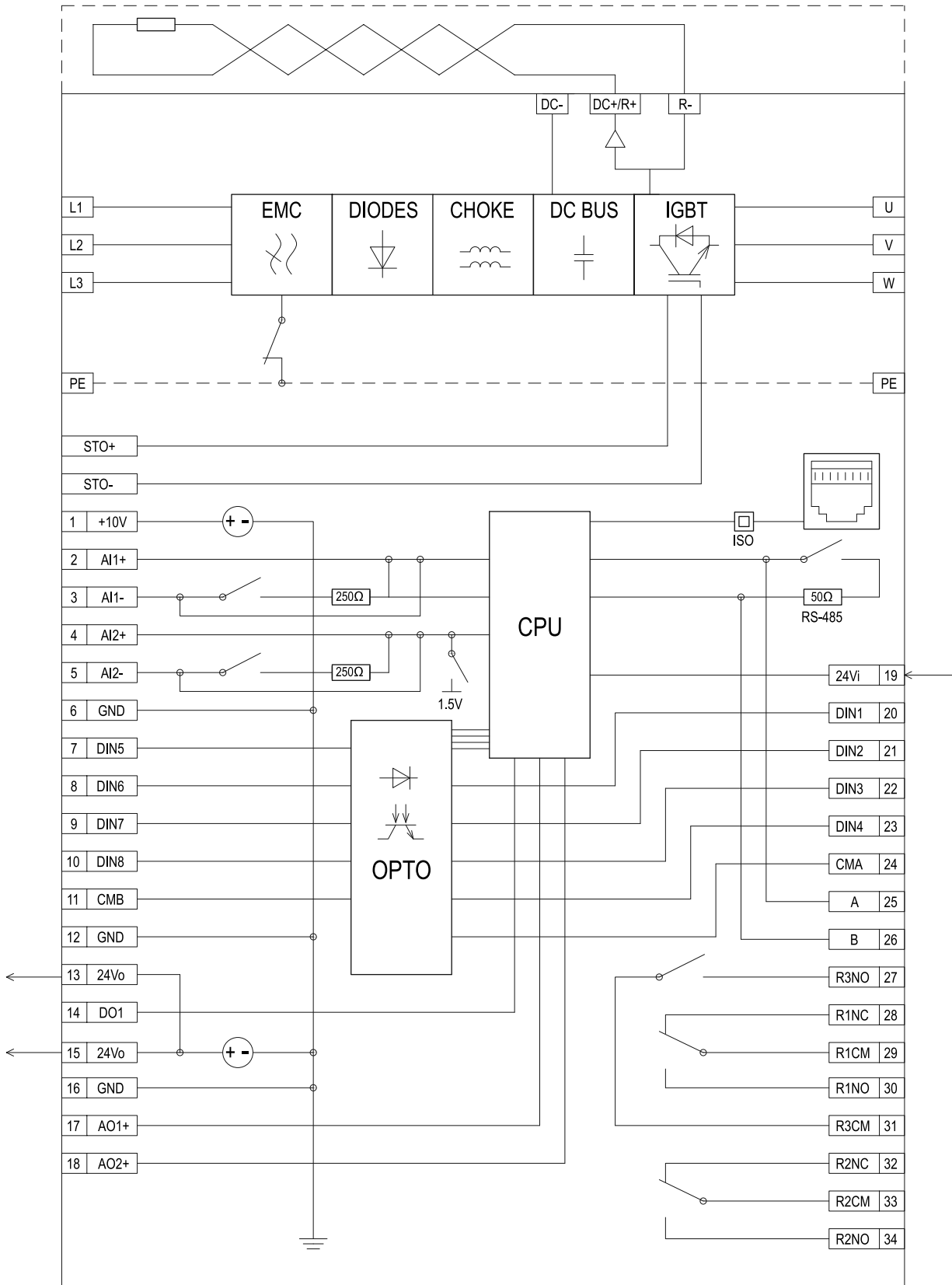



(en)

Caution!

In the territory of the EU Directive, the frequency-controlled devices and their accessories must be taken into operation only when the machine has been determined to fulfill the protection requirements of Machinery Safety Directive 89/392/EEC.

Ensure EMC-compliant installation. Lay control and communication cables spatially separated from the motor cable. Ensure a large contact area connection between p cable screen and PE.

(es)

¡Atención!

En el campo de aplicación de la normativa CE, los dispositivos controlados por frecuencia y sus correspondientes accesorios sólo deberán ponerse en marcha cuando se asegure que la máquina cumple con las exigencias de seguridad de la normativa de máquinas 89/392/CEE.

El montaje debe cumplir CEM. Los cables de mando y de conexión a red se deben instalar independientemente del cable de conexión al motor. El cable apantallado p se debe conectar a masa utilizando una amplia superficie de contacto.

(fr)

Attention !

En application des directives européennes, les convertisseurs de fréquence et leurs accessoires ne doivent être mis en service que s'il a été vérifié que la machine répond aux exigences de la directive machines 89/392/CEE.

Montage conforme aux règles de la CEM. Eloigner les câbles de commande et de réseau des câbles puissance. Relier le blindage au PE en assurant de grandes surfaces de contact.

(de)

Vorsicht!

Im Geltungsbereich der EG-Richtlinien dürfen die frequenzgesteuerten Geräte und deren Zubehör nur dann in Betrieb genommen werden, wenn festgestellt wird, dass die Maschine die Schutzanforderungen der Maschinenrichtlinie 89/392/EWG erfüllt.

EMV-gerechter Aufbau. Steuer- und Netzleitungen räumlich getrennt von der Motorleitung verlegen. p Leitungsschirm großflächig mit PE verbinden.

(it)

Attenzione!

Nel campo di validità delle direttive CE, gli apparecchi a controllo di frequenza e i loro accessori possono essere messi in esercizio soltanto se si verifica che la macchina soddisfa i requisiti di sicurezza della direttiva macchine 89/392/CEE.

Montaggio secondo CEM. Disporre i cavi comandi e di alimentazione separati dal cavo del motore. Collegare lo schermo del cavo p con PE con un'ampia superficie.

(nl)

Voorzichtig!

Binnen het geldigheidsgebied van de EC-richtlijnen mogen de frequentieregelde apparaten en de toebehoren daarvan alleen in bedrijf worden genomen, wanneer wordt vastgesteld, dat de machine aan de veiligheidsvoorschriften van de machinerichtlijn 89/392/EWG voldoet.

EMC-conforme constructie. Besturings- en netkabels ruimtelijk gescheiden van de motorkabel leggen. p Kabelafscherming over groot oppervlak met PE verbinden.

(da)

Forsigtig!

I det område, hvor EF-direktiverne er gældende, må det frekvensstyrede udstyr og dets tilbehør kun tages i anvendelse, hvis det konstateres, at maskinen opfylder beskyttelseskravene i maskindirektivet 89/392/EØF.

EMC-korrekt installation. Træk styre- og netledninger rumligt adskilt fra motorledningen. p Sørg for en stor kontaktflade mellem PES ledningsafskærmning og PE.

(el)

Προσοχή!

Στο πεδίο εφαρμογής των οδηγιών της ΕΚ, οι ελεγχόμενες μέσω συχνότητας συσκευές και τα παρελκόμενά τους επιτρέπεται να τίθενται σε λειτουργία μόνο εφόσον διαπιστωθεί ότι το μηχάνημα πληροί τις απαιτήσεις προστασίας της οδηγίας της ΕΚ για τα μηχανήματα 89/392/ΕΟΚ.

Κατασκευή σύμφωνα με τις απαιτήσεις ΗΜΣ. Εγκαθιστάτε τους αγωγούς ελέγχου και δικτύου ανεξάρτητα από τον αγωγό του κινητήρα. p Συνδέετε τη θωράκιση των αγωγών σε μεγάλη επιφάνεια με τη γείωση.

(pt)

Cuidado!

No âmbito das diretivas da CE, os aparelhos comandados por frequência e os respectivos acessórios só podem ser postos em operação se for comprovado que a máquina atende às exigências de proteção da diretiva de máquinas 89/392/CE.

Estrutura com compatibilidade eletromagnética. Dispor os fios de comando e de rede separados do fio do motor. p Ligar uma área grande da blindagem do cabo (PES) com o PE.

(sv)

Se upp!

I giltighetsområdet för EG-direktiven får de frekvensstyrda apparaterna och deras tillbehör endast tagas i drift när man fastställt att maskinen uppfyller skyddskraven i maskindirektiv 89/392/EEC.

EMC-anpassad uppbyggnad. Styr- och nätledningar dras avskilda från motorledningarna. p Förbind ledningsskärm över ett brett område med PE.

(fi)

Varo!

EU-direktiivien voimassaoloalueella taajuusohjatut laitteet ja niiden varusteet saa ottaa käyttöön vain silloin, kun todetaan, että kone täyttää konedirektiivin 89/392/ETY suojausvaatimukset.

EMC-mukainen rakenne. Ohjaus- ja verkkojohdot on asennettava tilalotteisesti erotettuina. Johdonsuoja on liitettävä laajasti maadoitukseen p.

(cs)

Pozor!

V rozsahu platnosti směrnice ES smí být frekvenčně řízené přístroje a jejich příslušenství uvedeny do provozu jedině tehdy, pokud je zjištěno, že stroj splňuje požadavky ochrany stanovené směrnicí 89/392/EHS o strojních zařízeních.

Nástavba odpovídající směrnici EMC. Řídící a síťová vedení pokládejte prostorově oddělená od vedení motoru. p Stínění vedení spojte velkoplošně s PE.

(et)

Ettevaatust!

EÜ-direktiivi kehtivuspiirkonnas võib sagedusjuhitavaid seadmeid ja nende lisaseadmeid kasutusele võtta ainult siis, kui on kindlaks tehtud, et masin vastab masinadirektiivi 89/392/EMÜ kaitsenõuetele.

Elektromagnetilisele ühilduvusele vastav ehitus. Juhtimis- ja võrgukaablid paigaldada mootori toitekaablist ruumiliselt eraldatuna. p Kaabli kaitseekraan ühendada ulatuslikult talitusmaandusega.

(hu)

Vigyázat!

Az EK irányelvek hatályossági területén a frekvenciavezérelt készülékeket és azok tartozékait csak akkor szabad üzembe helyezni, ha megállapítást nyert, hogy a gép megfelel a gépek biztonságáról szóló, 89/392/EGK számú irányelv biztonsági követelményeinek.

Elektromágnesesen összeférhető kivitelű biztosítson. A motorvezetékektől térben elkülönítve vezesse vezérlő és hálózati vezetékeket. p Nagy felületen csatlakoztassa a védőföldeléshez a vezetékkáryékolást.

(lv)

Ievērot piesardzību!

Valstīs, kurās ir spēkā EK direktīvas, ierīču ar frekvenčvadību un to piederumu ekspluatāciju drīkst sākt tikai tad, ja ir konstatēta iekārtas atbilstība Mašīnu direktīvā 89/392/EEK ietvertajām aizsardzības prasībām.

EMS atbilstoša uzbūve. Vadības un tīkla kabelus izvietot atsevišķi no motora kabeļa p Vada ekrānu plašā virsmā savienot ar PE.

Effective November 2017

lt Atsargiai!

EB direktyvų taikymo srityje dažniniu būdu valdomus įrenginius ir jų priedus leidžiama pradėti naudoti tik tada, kai nustatoma, kad įrenginys atitinka Mašinų direktyvos 89/392/EEB keliamus apsaugos reikalavimus.

Montažas turi atitikti EMS reikalavimus. Valdymo ir duomenų tinklo kabelius išdėstyti atokiai nuo variklio kabelio. p Kabelio ekraną dideliu paviršiumi sujungti su žeminiu.

pl Ostrożnie!

Na obszarze obowiązywania dyrektyw WE urządzenia sterowane częstotliwościowo wolno wprowadzać do eksploatacji tylko wtedy, gdy zostanie stwierdzone, że maszyna spełnia wymagania ochronne dyrektywy maszynowej 89/392/EWG.

Konstrukcja zgodna z dyrektywą w sprawie kompatybilności elektromagnetycznej (EMC). Przewody sterowania i zasilania elektrycznego należy układać oddzielnie od przewodu silnika. p Ekranowanie połączyć z przewodem uziemiającym na większej powierzchni.

sl Pozor!

Na območju veljavnosti direktiv ES je zagon frekvenčno krmiljenih naprav in njihovega pribora dovoljen le tedaj, ko je bilo ugotovljeno, da stroj ustreza varnostnim zahtevam Direktive o strojih 89/392/EGS.

Montaža v skladu z EMZ. Krmilne in omrežne vodnike napeljite ločeno od vodnikov motorja p Oklep vodnika na veliki površini povežite z zaščitnim vodnikom.

sk Pozor!

V krajinách, ktoré spadajú pod pôsobnosť smerníc ES smú byť rádiovo ovládané zariadenia a ich príslušenstvo uvedené do prevádzky len ak je zabezpečené, že stroj spĺňa ochranné ustanovenia smernice č. 89/392/EHS o strojových zariadeniach.

Montáž v súlade s požiadavkami elektromagnetickej kompatibility. Ovládacie a sieťové vedenia uložte v priestore oddelene od vedenia motora. p Zabezpečte veľkú kontaktnú plochu medzi káblovým tienením a PE.

bg Внимание!

В сферата на действие на изискванията на ЕС устройствата с честотно управление и техните допълнителни устройства могат да бъдат приведени в употреба, само ако се установи, че оборудването съответства на изискванията за безопасност на машинно оборудване спрямо 89/392/EWG.

Монтаж с електромагнитна съвместимост. Полагане на контролните и мрежови проводници пространствено отделно от проводника на двигателя. p Осигурете по-голяма контактна площ между силовия екран и PE.

ro Precauție!

În cadrul sferei de aplicare a directivelor UE dispozitivele controlate prin frecvență și accesoriile acestora au voie să fie puse în funcțiune doar dacă se stabilește că aparatul îndeplinește cerințele Directivei 89/392/CEE privind mașinile.

Montajul trebuie să fie compatibil EMC. Poziționați cablurile de control și de rețea la distanță de cablul motorului. p Asigurați o suprafață de contact mare între izolația cablului și PE.

ru Осторожно!

В сфере действия директив ЕС устройства с частотным управлением и их оснащение должны вводиться в эксплуатацию только в том случае, если установлено, что данное оборудование соответствует требованиям по защите Директивы о машинном оборудовании 89/392/EWG.

Сборка соответственно электромагнитной совместимости. Линии управления и электросети прокладывать в пространственном отношении отдельно от линии двигателя. p силовой экран соединять с PE по большой площади.

zh 注意!

根据欧盟设备一致性规范，安装频率控制设备及其配件时，应确保设备满足机器规范 89/392/EWG 中关于设备保护的要求。

p 按照电磁兼容规范正确安装。应将控制电缆和电源电缆与电机电缆分开。大面积采用 PE 包裹电缆。

UL cautions, warnings, and instructions

Wiring warnings for electrical practices and wire sizes

The Cautions, Warnings, and Instructions in this section summarize the procedures necessary to ensure an inverter installation complies with Underwriters Laboratories® guidelines.



(en)

Warning!

Use 60/75 °C Cu wire only or equivalent.



(en)

Warning!

Open Type Equipment.



(en)

Warning!

Suitable for use on a circuit capable of delivering not more than 5,000 rms symmetrical amperes:

- 240 V maximum for DG1-32 models
- 500 V maximum for DG1-34 models
- 600 V maximum for DG1-35 models

Circuit breaker and fuse sizes

The adjustable frequency drive's connections to input power must include UL listed inverse time circuit breakers with 600V rating, or UL listed fuses.

Terminal tightening torque and wire size

The wire size range and tightening torque for field wiring terminals are presented.

Wire connectors



(en)

Warning!

Field wiring connections must be made by a UL listed and CSA certified ring lug terminal connector sized for the wire gauge being used. The connector must be fixed using the crimping tool specified by the connector manufacturer.

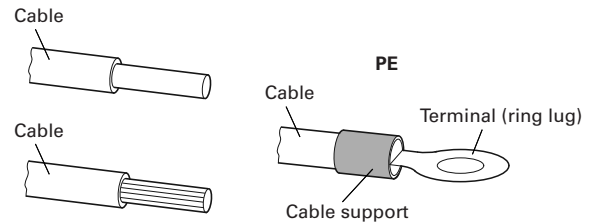

Motor overload protection

DG1 adjustable frequency drives provide solid-state motor overload protection, which depends on the proper setting of the following parameter: P7.2 "current limit."

Set the rated current [Amperes] of the motor(s) with the above parameters. The setting range is 0.2 * rated current to 2 * rated current, → manual MN040002EN.



(en)

Warning!

When two or more motors are connected to the inverter, they cannot be protected by the electronic overload protection. Install an external thermal relay on each motor.

Technical support contact information

	Americas	EMEA	APAC
Website	www.eaton.com/drives	www.eaton.eu/electrical	www.eaton.com.cn/electrical
Email	VFDaftermarketEG@eaton.com	AfterSalesEGBonn@eaton.com	CustomerServicePDCNA@eaton.com
Phone	1-877-386-2273 (8:00 a.m. to 6:00 p.m. Eastern Time U.S. [UTC-5]) 800-543-7038 (6:00 p.m. to 8:00 a.m. Eastern Time U.S. [UTC-5])	+49 (0) 180 5 223822	800 9881203

Eaton

1000 Eaton Boulevard
Cleveland, OH 44122
United States
Eaton.com

© 2017 Eaton
All Rights Reserved
Printed in USA
Publication No. IL040016EN / Z20125
November 2017



Eaton is a registered trademark.

All other trademarks are property
of their respective owners.