



Instructions for V201, V211 NEMA Size 4 Vacuum Contactor Nonreversing or Reversing

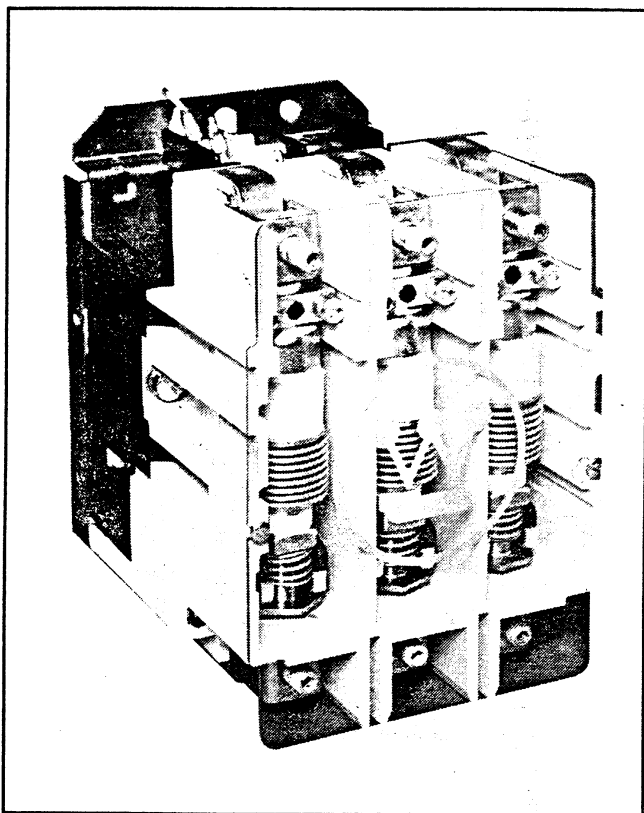

Fig. 1 V201 Nonreversing Contactor

THE CONTACTOR

This NEMA Size 4 contactor is designed for the control of inductive or non-inductive loads at voltages between 200 and 600, AC. It is suitable for mounting on either steel or insulated panels. All parts are front removable. Contactors should be protected against short circuits by branch circuit protective devices selected in accordance with the National Electrical Code (NEC). Care must be exercised to comply with local, state, and national regulations, as well as safety practices, for this class of equipment.

Mount each contactor with three $\frac{1}{4}$ " x 20 bolts. Use flat washers on bolts entering slotted holes or keyholes.

OPERATION

The V201 contactor has its main contacts sealed inside ceramic tubes from which all air has been evacuated, i.e., the contacts are in vacuum. No arc boxes are required, because any arc formed between opening contacts in a vacuum has no ionized air to sustain it. The arc simply stops when the current goes through zero as it alternates at line frequency. The arc usually does not survive beyond the first half cycle after the contacts begin to separate. The ceramic tube with the moving and stationary contacts enclosed is called a **vacuum inter-**

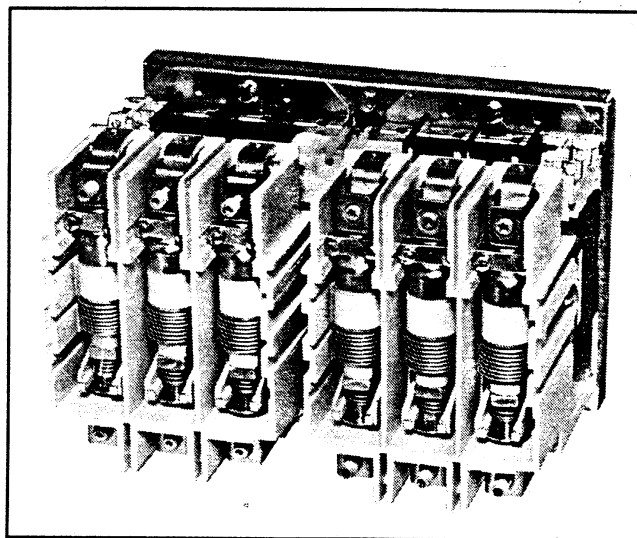

Fig. 2 V211 Reversing Contactor

rupter or a **bottle**, and there is one such bottle for each pole of the contactor. A two-pole contactor has two vacuum bottles, and a three-pole contactor has three vacuum bottles. A metal bellows (like a small, circular accordion) allows the moving contact to be closed and pulled open from the outside without letting air into the vacuum chamber of the bottle. Both the bellows and the metal-to-ceramic seals of modern bottles have been improved to the point that loss of vacuum is no longer cause for undue concern.

The moving contacts are driven by a molded plastic crossbar supported by two pre-lubricated ball bearings that are clamped in alignment for long life and free motion.

The contacts in an unmounted bottle (vacuum interrupter) are normally-closed, because the outside air pressure pushes against the flexible bellows. For contactor duty, the contacts must be "normally-open" when the operating magnet is not energized. Therefore, the contacts of the vacuum bottles must be held apart mechanically against the air pressure when used in a contactor. In the contactor, all of the bottles are held open by a single kickout spring in the rear of the contactor. The kickout spring pushes against the moving crossbar and thereby forces the bottles into the open position. In the open position, the crossbar is pulling the moving contacts to hold them open.

The contactor is intended to be mounted with its mounting plate vertical and the moving stem of the vacuum bottles aimed down. However, mounting position is not critical.

INSTALLATION

This industrial type control is designed to be installed, operated, and maintained by adequately trained workmen. These instructions do not cover all details, varia-

INSTALLATION (cont.)

tions, or combinations of the equipment, its storage, delivery, installation, check-out, safe operation, or maintenance. Care must be exercised to comply with local, state, and national regulations, as well as safety practices, for this class of equipment.

A three-pole contactor is suitable for use with a motor rated not more than the values shown in the table below.

CONTROLLER RATINGS — 3 POLE CONTACTORS				
THREE-PHASE HORSEPOWER AT				
200V	230V	380V	460V	575V
40	50	75	100	100
MAXIMUM CURRENT RATINGS				
Continuous Carrying Open	Continuous Carrying Enclosed	Motor, Transformer or Capacitor Make or Break		
150A RMS	135A RMS	1581A Peak*		
Maximum Capacitor Switching — 3 Phase 80 kvar at 460 volts; 100 kvar at 575 volts				
* Including offset at .45 power factor				

Two-pole contactors have the same current ratings as three-pole devices but are not suitable for controlling three-phase motors.

AUXILIARY CONTACTS — TYPE J

A J1C auxiliary contact unit with one normally-open and one normally-closed, delayed break, pole is supplied mounted in the left-center recess of each non-reversing contactor. The normally-closed pole is factory wired to switch a resistor and capacitor in series with the coil winding as the contactor closes. The contactor must not be operated with this switch disconnected or removed, as coil overheating and failure would result. Two additional J11 contact units are supplied on reversing contactors, wired as shown in Figure 7 to provide electrical interlocking of the forward and reverse contactors. This electrical interlocking should be incorporated into any reversing control scheme. A maximum of four auxiliary units can be installed in each nonreversing contactor (three in each reversing contactor). They mount by means of a spring clip and retainer screw. To remove the auxiliary contacts, loosen the retainer screw several times (counterclockwise) and then slide the auxiliary contact unit out of the recess.

COIL

The contactor accepts AC control power connected directly to the coil terminals (Figure 3), but uses a full-wave rectifier to get unfiltered DC magnet excitation through a single-winding coil. A capacitor and resistor are switched in series with the coil winding just before the armature fully closes, using a delayed break, normally-closed J1C auxiliary contact. This arrangement

TYPE J AUXILIARY CONTACTS			
Contact Type	Catalog No.		
2 Normally Closed	J02		
2 Normally Open	J20		
1 Normally Open and 1 Normally Closed	J11		
1 Normally Open and 1 Normally Closed, Delayed Break	J1C		
TYPE J CONTACT RATINGS (A600, R300)			
Voltage	Continuous	Make	Break
120-600 VAC	10A	7200VA	720VA
72-120 VAC	10A	60A	720VA
28-72 VAC	10A	60A	10A
28-300 VDC	1.0A	28VA	28VA

allows a relatively high current through the coil for pickup, then reduces the coil current to a low value sufficient to hold the magnet closed without overheating. All of the coil components are encapsulated.

FACE PLATE AND GAUGE

Each contactor comes equipped with a trademark face plate and an overtravel gauge mounted on the front of the unit. They are attached with two self-tapping screws that need not be completely removed in order to remove the face plate or overtravel gauge. Simply backout the screws a few turns and slide the face plate and overtravel gauge to a position where the screw heads can clear the large diameter portion of the keyhole slots. Remount the face plate and overtravel gauge by reversing the procedure, taking care to tighten the screws to just snug. The face plate must be removed to gain access to the vacuum bottles and check the overtravel gap. See **CONTACT WEAR ALLOWANCE**.

CONTACT FORCE AND ALTITUDE

A vacuum contactor is affected by atmospheric pressure on the bellows of the vacuum bottles. Up to an altitude of 6600 feet, the contactor is designed to tolerate normal variations in barometric pressure. If the contactor is to be operated over 6600 feet above sea level, consult the factory.

CONTACT WEAR ALLOWANCE

Contact material vaporizes from the contact faces during every interruption and condenses inside the bottle. This is normal, and is provided for by **overtravel**, or wear allowance. When the contactor is fully closed, there is a gap between the pivot plate and the bottle stem. See Figure 3. As the contacts wear, this gap decreases. When the gap on any bottle goes **below .010 in.**, the unit should be replaced. Use the .010 in. thick fork-shaped overtravel gauge supplied for this measurement, Part No. 9085A58H01.

CAUTION: The easiest way to close the contactor is to energize the coil. If the coil is energized for this or other maintenance, use adequate care to guard against electrical shock.

Do not re-adjust the bottles to reset overtravel as the bottles wear. Once placed into service, overtravel should be checked but not adjusted.

WARNING

Failure to completely disconnect the contactor from all power sources, including control circuit power, prior to inspection or servicing may result in severe injury or death.

CHECK-OUT, VACUUM INTERRUPTERS

The dielectric strength of the interrupters should be checked before the contactor is energized for the first time and regularly thereafter to detect any deterioration in the dielectric strength of the contact gap. A good interrupter will withstand a 5.5 kV, 50 or 60 hertz test across a .075 inch contact gap, which is the normal new gap.

When a vacuum bottle is tested with voltages over 5000 volts across its open gap, there is some possibility of generating X-rays. Test time should be minimized, and personnel should not be closer than 10 feet. This is a precaution until such time as the possible hazard is better understood and standards are published.

Periodic dielectric tests across open contacts are

desirable since under certain operating conditions the contactor may perform satisfactorily even though one vacuum interrupter becomes defective. Dielectric tests should be made with the contactor in the same position it has when operating.

The interval between periodic tests depends on the number of operations per day, environmental factors, and experience. It is a matter of operator judgement, and philosophy of preventive maintenance.

CHECK-OUT, MECHANICAL

Make sure all power circuits are de-energized and isolated. The contactor can be checked in its cabinet or outside. A mechanical interlock **must** be checked installed, to make certain that it functions properly.

If the contactor is checked in its cabinet, make certain that the contactor coil is electrically isolated, to prevent feedback into a control transformer that could be hazardous.

Connect a separate power source of correct AC voltage to the coil of the contactor. Operate appropriate pushbuttons to close and open the contactor.

While the contactor is closed, observe the overtravel gap between the pivot plates on the crossbar and the bottle stem on each pole. This overtravel gap should be no less than .046 inch when the contactor is new. If less, refer to **CONTACT WEAR ALLOWANCE**. Disconnect separate power source before proceeding.

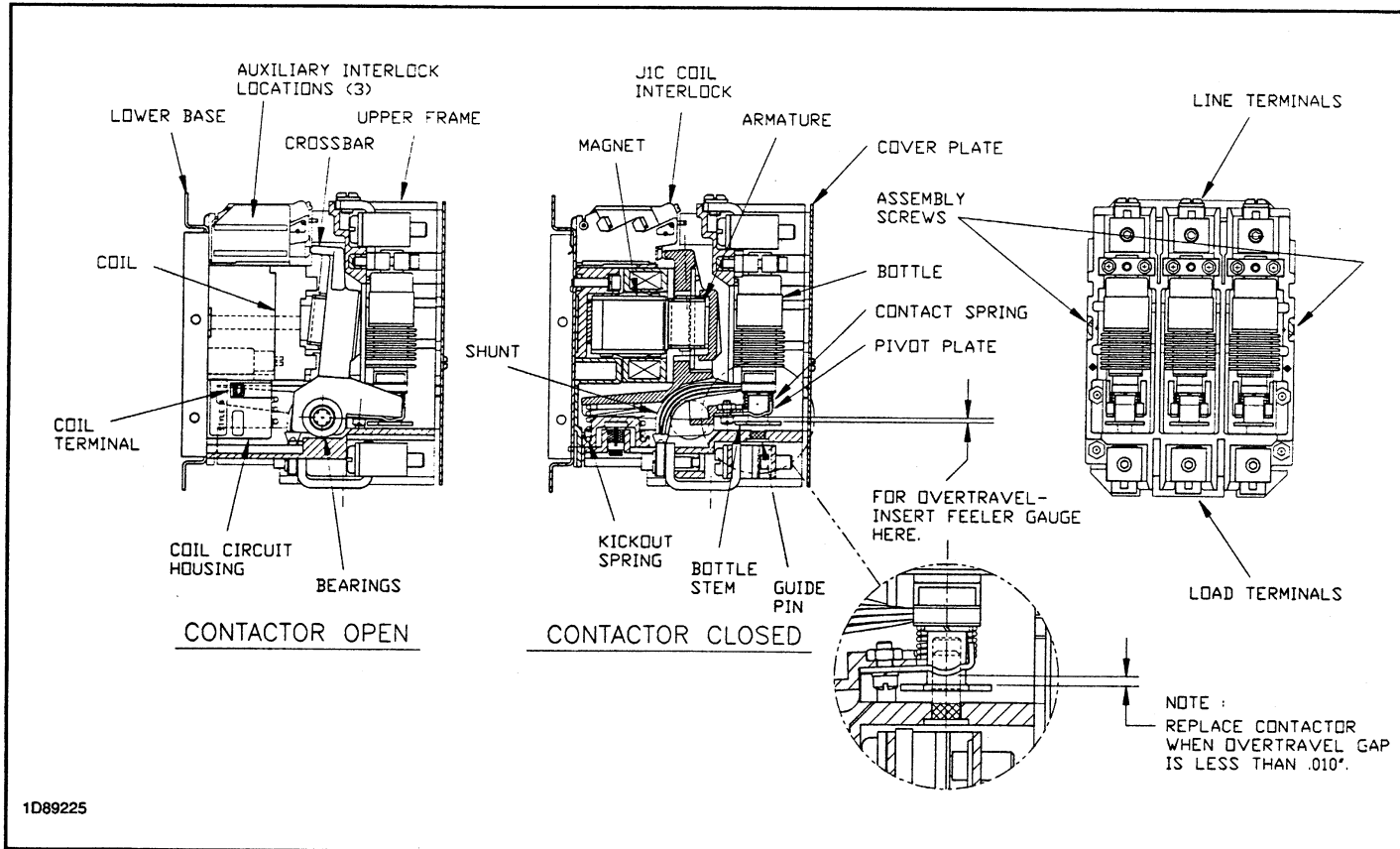

Fig. 3 Size 4 Vacuum Contactor

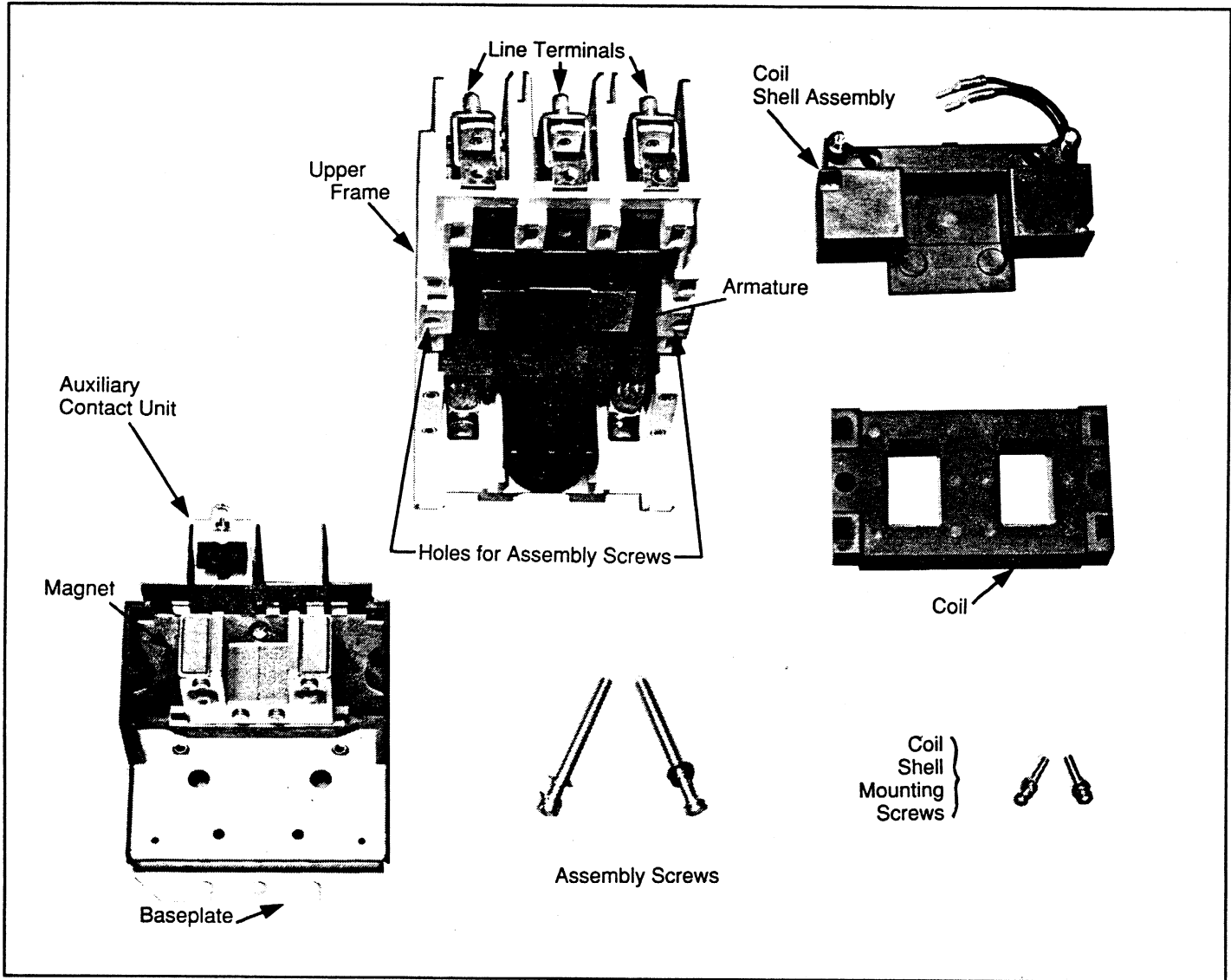

Fig. 4 Size 4 Vacuum Contactor Disassembled

CHECK-OUT, INSULATION LEVEL

After installation, and before energizing the contactor for the first time, measure and record the insulation resistance between poles and from each pole to ground. It is not practical to specify an absolute value for this reading since it is dependent on other connected apparatus, and conditions of service. However, any unusually low reading or sudden reduction in this reading after the contactor has been in service indicates a possible source of trouble, and the cause should be determined and corrected before restoring power.

MECHANICAL INTERLOCK

A mechanical interlock is used when a pair of controllers must be mechanically protected against the closing of one when the other is already closed. For the V211 configuration, the Type M33 is used. A mechanical interlock occupies one auxiliary contact recess in each contactor.

MAINTENANCE

Establish a maintenance program as soon as the contactor is installed and put into operation. After the contactor has been inspected a number of times at monthly intervals, and the condition noted, the frequency of inspection can be increased or decreased to suit the conditions found, depending upon the severity of the contactor duty. It is a matter of operator judgement.

This industrial type control is designed to be installed, operated, and maintained by adequately trained workmen. These instructions do not cover all details, variations, or combinations of the equipment, its storage, delivery, installation, check-out, safe operation, or maintenance. Care must be exercised to comply with local, state, and national regulations, as well as safety practices, for this class of equipment.

All work on this contactor should be done with the main circuit disconnect device open. Also, disconnect power from any other external circuits. Discharge any hazardous capacitors.

V201, V211 NEMA SIZE 4 VACUUM CONTACTOR

I.L. 17266B

Loss of Vacuum

Gross loss of vacuum is highly unlikely. It is also unlikely, but possible, to have a very slight leak that does not change the bottle force appreciably, but which might seriously damage the ability of the bottle to interrupt. In this regard, it must be remembered that in a three-phase ungrounded circuit, it is possible for any two good interrupters to successfully interrupt the circuit even if a third interrupter is weak. But this condition should not be allowed to continue. It can be detected only by an electrical test. See **CHECK-OUT, VACUUM INTERRUPTERS.**

WARNING: All work on this contactor should be done with the main disconnect device open. As with any contactor of this voltage, there is danger of electrocution and/or severe burns. Make certain that power is off.

Inspection After Short Circuit

The V201 contactor is intended to be protected by power fuses and/or a circuit breaker in accordance with the National Electrical Code. However, the magnitude of a short circuit may exceed the damage threshold of the vacuum bottles. After a short circuit, the unit should be examined for any apparent physical damage, or deformation of conductor bars and cables. If there is any evidence of severe stress, it is recommended that the unit be replaced. If the overtravel has changed significantly (from the last inspection) on one or more bottles, the unit should be replaced.

A dielectric test would not by itself confirm that the unit should be returned to service after a fault. However, if there is no physical evidence of stress, and if the overtravel exceeds the .010 in. minimum, the bottles **must** then be dielectrically tested as outlined previously. If physical stress, overtravel, and dielectric are O.K., it is reasonable to return the unit to service after a fault.

To Replace The Coil

Each replacement coil kit consists of an encapsulated coil winding and a coil circuit assembly which contains a rectifier, capacitor and resistor (Figure 4). These two units plug together in the assembled contactor, and **must be properly matched according to rated control voltage.** In the event of a coil failure, both units should be replaced. To replace the coil and coil circuit assembly, remove the contactor from the panel.

To remove the old coil, loosen the two assembly screws located at the sides of the contactor. Pull the loosened upper frame forward, and pull the coil straight up from the magnet. Then remove the two #10-32 screws that hold the coil circuit assembly to the baseplate, and set aside. Loosen the terminal screw on the delayed-break, normally-closed J1C auxiliary contact (mounted in the left-center recess of the contactor), and remove the two wires that connect to the coil circuit assembly. Pull the coil circuit assembly straight up from the lower base, feeding the two wires on the bottom back through the holes in the baseplate.

Reverse the above procedure to mount the new coil

circuit assembly, taking care to guide the wires back through the holes in the baseplate and connect them to the J1C auxiliary contact terminals. Plug the new coil into the coil circuit assembly, lining up the two pins in the bottom of the coil with the mating receptacles on the coil circuit assembly. Replace the upper frame. Slide the assembly screws into their respective holes and let the screws hang from the upper frame to facilitate reassembly. This step accommodates the beveled slot in each side of the upper frame and lets each screw be perpendicular to the baseplate. Check the auxiliary contacts for secureness when repositioning the upper frame. Tighten the assembly screws. Refer to Table I.

While the upper frame assembly is being installed on the lower frame make absolutely certain the J1C and other auxiliary contacts are pushed completely back into their cavities and secured. **It is essential that the J1C auxiliary contact be mounted correctly and securely in its cavity or a coil failure will result.**

REPLACEMENT COIL KIT: ORDER BY PART NUMBER, VOLTAGE, AND FREQUENCY

AC OPERATING COIL KITS		
Voltage	Freq. (Hz)	Part Number 2-3 pole
120/110	60/50	9085A57G01
240/220	60/50	9085A57G02
480/440	60/50	9085A57G03
600/550	60/50	9085A57G04

AC COIL DATA (TYPICAL VALUES)

Poles	Inrush VA	Sealed VA	Sealed Watts
2-3	300	30	8
Pickup Time: 18-24 ms		Dropout Time: 90-120 ms	

TABLE I — RECOMMENDED DRIVING TORQUE

Location (Qty.)	Driving Torque (lb.-in.)
Assembly Screw (2)	50 — 60
Coil Wire Connector (2)	8 — 9
Main Power Connector (2/pole)	90 — 100

SHORT-CIRCUIT RATINGS

Calculate the fault current available at the point of installation and select a short-circuit protective device that has the appropriate voltage rating, adequate interrupting capability and is consistent with the short-circuit withstand ratings shown in Table II.

This contactor is suitable for use on a circuit capable of delivering not more than the current (rms symmetrical amperes) shown below in circuits rated not more than the voltage shown in Table II.

TABLE II — SHORT-CIRCUIT WITHSTAND RATINGS						
Short-Circuit Protective Device (SCPD)	Max. Rating SCPD	Circuit Breaker Interrupting Rating	Short-Circuit Rating		Typical Disconnect Device Cat No.	
			Current	Voltage		
Class H Fuse	400A	—	10,000A	600V	DS465	
Class J Fuse	400A	—	100,000A	600V	HKB Interrupter	
Class R Fuse	400A	—	100,000A	600V	HKB Interrupter	
Class T Fuse	400A	—	100,000A	600V	HKB Interrupter	
Magnetic Only ¹ Type CB ²	150A*	Marked HMCP	50,000A	600V	HMCP	
			100,000A	480V		
Thermal/Mag. Type CB ³	250A		25,000A	25,000A	600V	HJD
			65,000A	65,000A	480V	
			35,000A	35,000A	600V	JDC
			100,000A	100,000A	480V	
Mag. Only Type CB + CL ⁴	150A*	HMCP+ Current Limiter	100,000A	600V	HMCP + EL	
Thermal/Mag. Type CB + CL ⁵	250A	200,000A	100,000A	600V	LA +TRI-PAC	
Thermal/Mag. Type CLB ⁶	250A	150,000A	100,000A	480V	LCL	

* To comply with the NEC, thermal overload relays must be included in the branch circuit.
¹ Instantaneous Adjustable Trip
² Circuit Breaker
³ Inverse-Time Circuit Breaker
⁴ Instantaneous Adjustable Trip with Current-Limiting Attachment
⁵ Inverse-Time with Built-In Current-Limiting Fuses
⁶ Inverse-Time Current-Limiting Breaker

POWER CIRCUIT TERMINALS	
Controller Size 4	Wire Size #12 - 4/0 AWG
Wire with copper conductors only.	

TABLE III — MINIMUM CLEARANCES	
Maintain minimum clearance between live parts and grounded parts and between live parts of opposite polarity.	
System Voltage Not greater than 600 volts	Minimum Clearance .375 inches

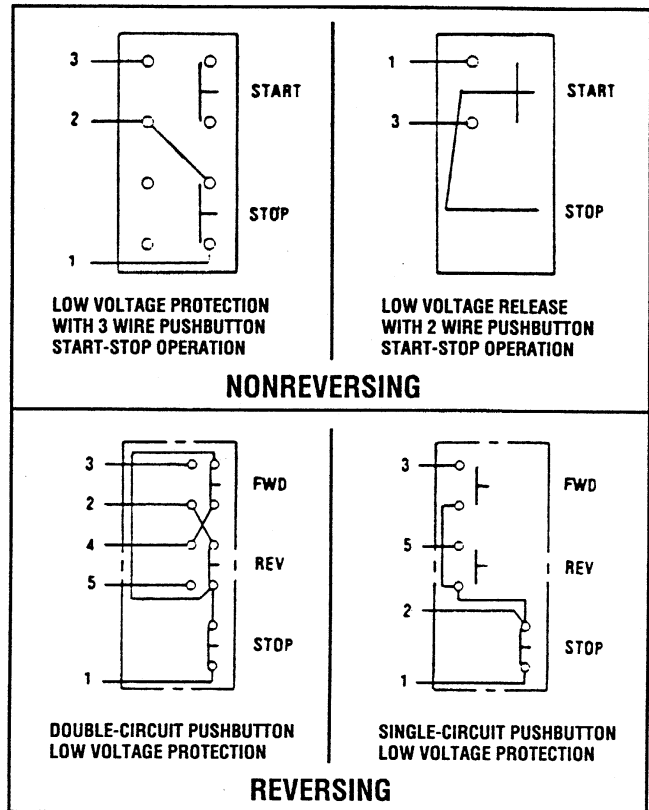

Fig. 5 Control Station Connection Diagrams

TABLE IV — ACCESSORIES		
Fuse Block Kits — Meet requirements of NEC concerning common control fusing.		
Order Cat. No.	Qty.	Description
F56	2	Contactor mounted Fuse Holder for 1 600 volt Buss KTK Fuse
FKR	1	Panel mounted Fuse Holder for 2 Class CC (Buss KTKR) Fuses*
*Use when available fault current exceeds 10,000 amperes		
Order Fuses Separately By Ampere Rating.		
Controller Size	Minimum Wire Size in Control Circuit	Suggested Fuse Size†
4	#16 AWG	10 AMP
† When using a control transformer, select fuse size per the National Electrical Code.		

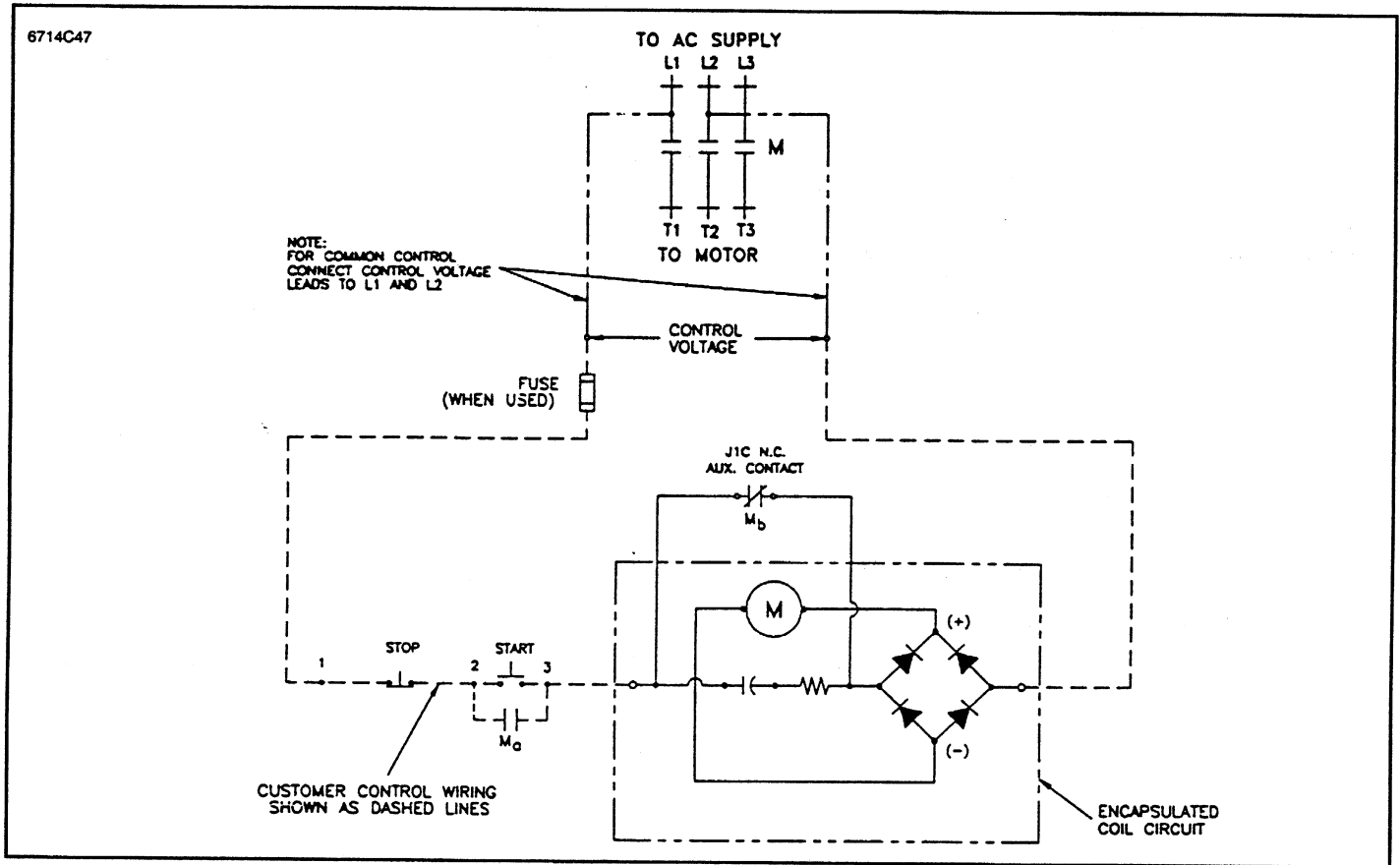

Fig. 6 Connection Diagram, V201

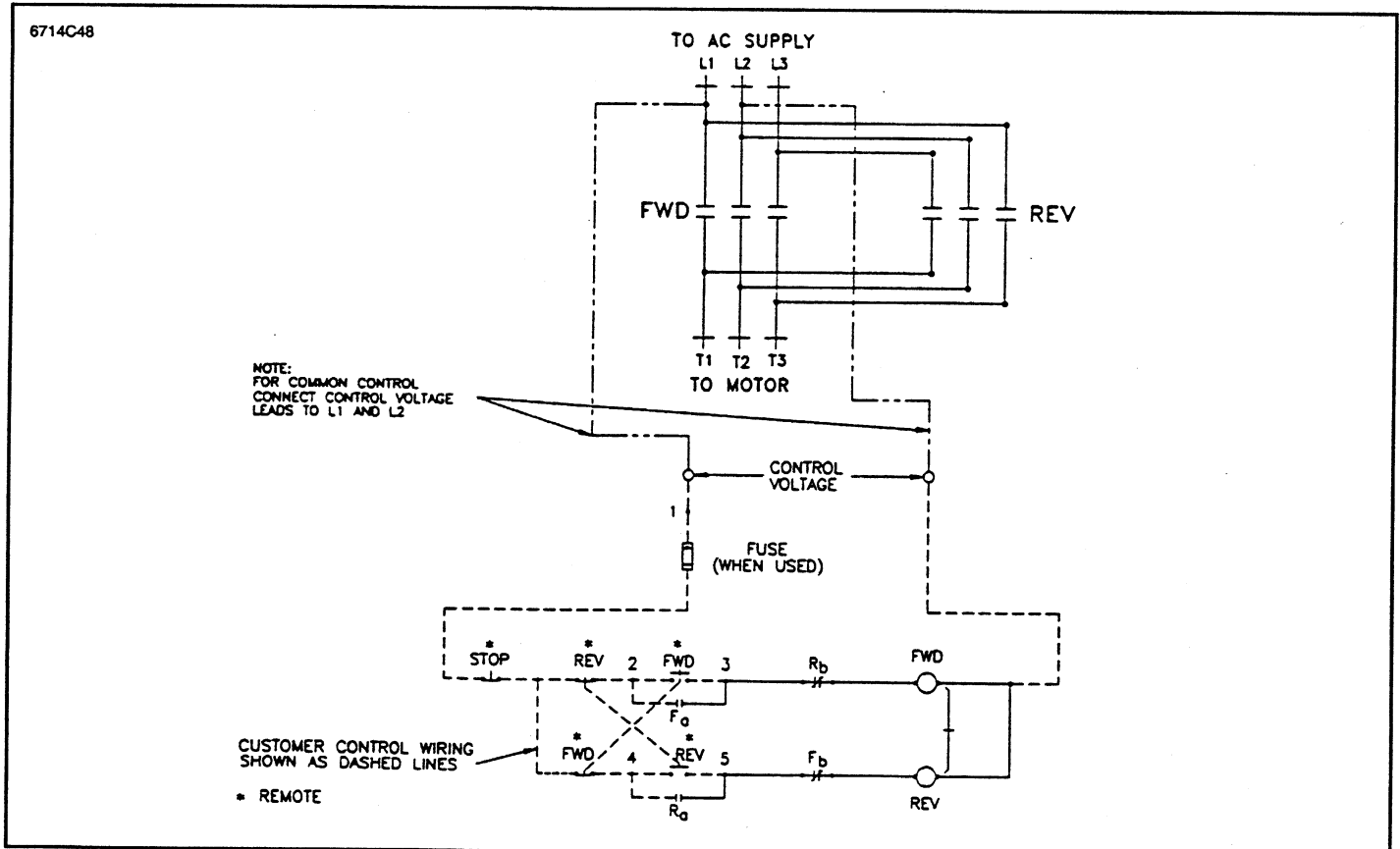

Fig. 7 Connection Diagram, V211

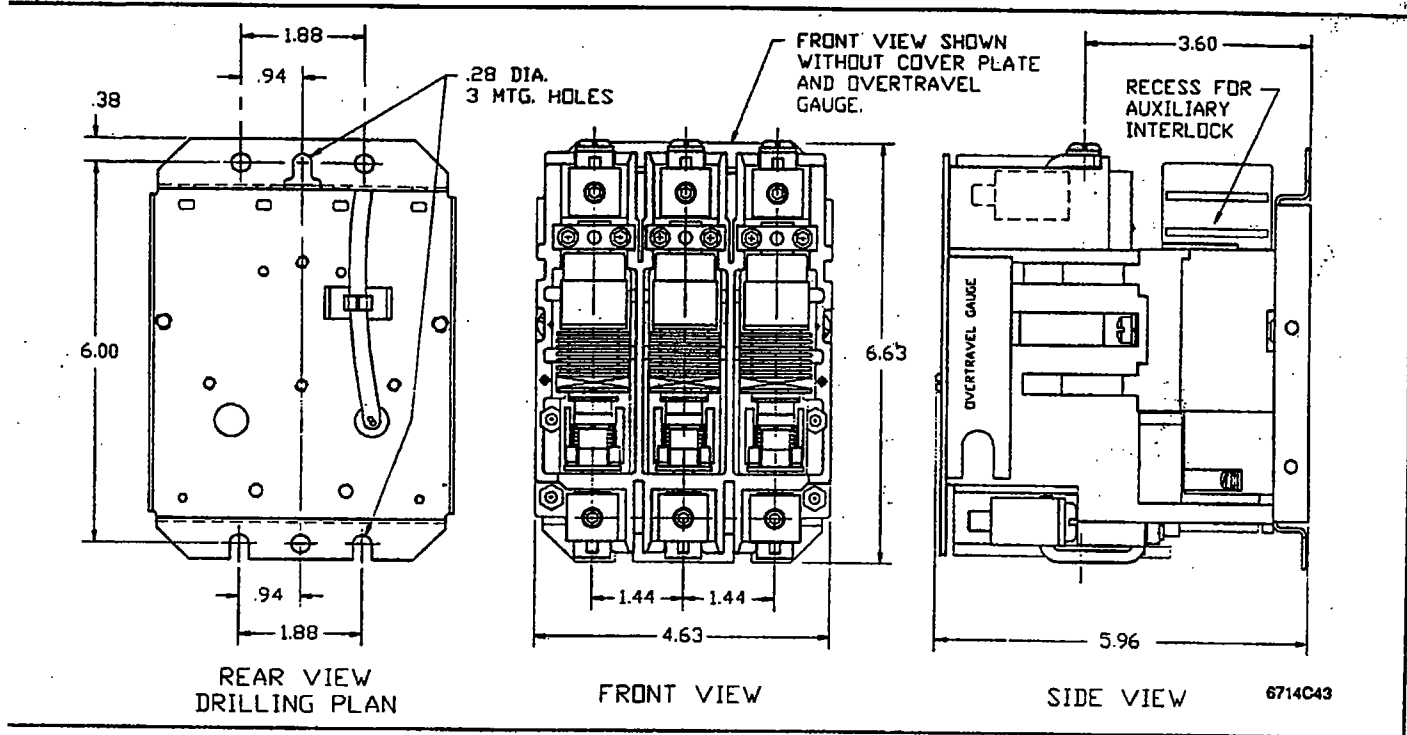

Fig. 8 Nonreversing Contactor (V201) Dimension Drawing (Dimensions in inches)

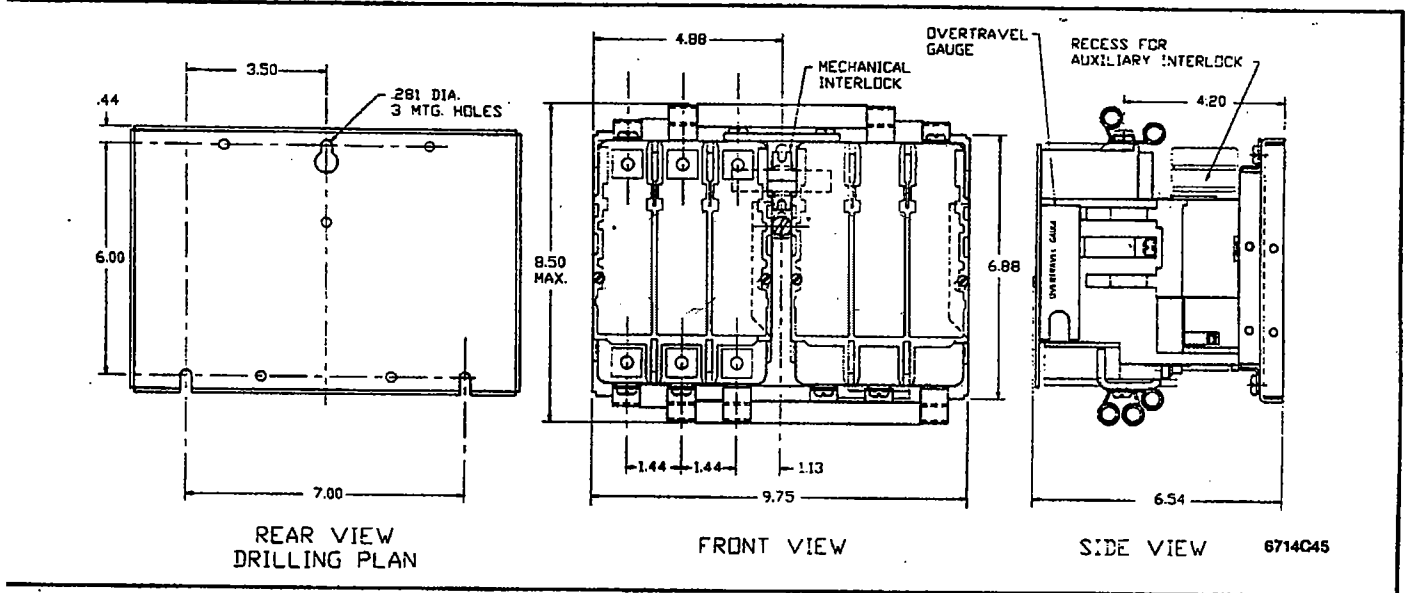

Fig. 9 Reversing Contactor (V211) Dimension Drawing (Dimensions in inches)