



User Manual SmartWire-DT Gateway

EU5C-SWD-PROFINET



Hilscher Gesellschaft für Systemautomation mbH

www.hilscher.com

DOC120304UM03EN | Revision 3 | English | 2012-07 | Released | Public

Table of Contents

1	INTRODUCTION.....	5
1.1	About This Manual.....	5
1.1.1	List of Revisions	5
1.1.2	Conventions in this Manual	6
1.2	Versions of Devices, Firmware, Software Tools, Drivers and Device Description File	7
1.3	Software Package.....	8
1.3.1	Contents of the Product DVD	8
1.3.2	How to Use the Product DVD	9
1.3.3	Notes on Installing the USB Driver.....	10
1.4	Documentation Overview.....	11
1.5	Legal Notes.....	12
1.5.1	Copyright	12
1.5.2	Important Notes	12
1.5.3	Exclusion of Liability	13
1.5.4	Warranty	13
1.5.5	Export Regulations	14
1.5.6	Registered Trademarks.....	14
2	SAFETY	15
2.1	General Note	15
2.2	Intended Use	15
2.3	Personnel Qualification.....	15
2.4	References Safety	15
2.5	Safety Instructions to Avoid Personal Injury	16
2.5.1	Electrical Shock Hazard	16
2.5.2	Danger of Unintended Starting Up of Machines.....	16
2.6	Safety Instructions to Avoid Property Damage	17
2.6.1	General Safety Instructions Concerning Supply Voltage	17
2.6.2	Device Destruction by Exceeding Allowed Supply Voltage.....	17
2.6.3	Electrostatic Sensitive Device	18
2.7	Labeling of Safety Messages.....	19
3	DESCRIPTIONS AND REQUIREMENTS	20
3.1	Device Description EU5C-SWD-PROFINET Gateway	20
3.1.1	Overview.....	20
3.1.2	Configuration	21
3.1.3	Interfaces.....	22
3.1.4	Diagnosis.....	22
3.1.5	Firmware Update.....	22
3.2	Prerequisites for Operation.....	23

3.2.1	Network System	23
3.2.2	Power Supply	23
4	DEVICE PICTURE, CONNECTORS AND LEDS	25
4.1	Device Picture.....	25
4.2	Positions and Meaning of the LEDs.....	26
4.2.1	Positions of the LEDs	26
4.2.2	Descriptions of the LEDs.....	27
4.3	Pinning PROFINET IO Interface	29
5	GETTING STARTED.....	30
6	INSTALLING EU5C-SWD-PROFINET GATEWAY	31
6.1	Safety Messages	31
6.2	Mounting Gateway.....	32
6.2.1	Mounting Gateway onto Top Hat Rail	32
6.2.2	Removing Gateway from Top Hat Rail.....	34
6.3	Connecting Gateway to Power Supply	35
6.4	Connecting SmartWire-DT.....	37
6.5	Connecting PROFINET IO.....	38
6.6	EMC-Conformant Wiring of the Network	39
7	COMMISSIONING EU5C-SWD-PROFINET GATEWAY	40
7.1	Configuring SmartWire-DT network in Gateway.....	40
7.1.1	Reading the SmartWire-DT Configuration	41
7.1.2	Switching On Gateway When Target Configuration Is Stored	42
7.2	Configuring Gateway in PROFINET IO Network	43
7.2.1	GSDML Device Description File.....	43
7.2.2	Creating Communication With PROFINET IO	43
7.3	Example: Using STEP 7 to Create a Gateway Project in PROFINET IO Network Controlled By S7-300 PLC.....	45
7.3.1	Overview.....	45
7.3.2	Step-by-Step Instructions for Configuring Gateway with STEP 7	46
7.3.3	Step-by-Step Instructions for Loading PROFINET IO Configuration to S7-300 PLC.....	67
7.3.4	Step-by-Step Instructions for Programming in STEP 7: Display I/O Data	71
7.3.5	Adding SmartWire-DT Slaves Later	79
7.3.6	Acyclical Data Communication S7-300 PLC	80
7.3.7	Using STEP 7 to Assign Device Name or IP Address on the Gateway	81
8	PROFINET IO DATA COMMUNICATION	84
8.1	Acyclical Communication	84
8.1.1	Address Mapping.....	84
8.1.2	Error Detection and Error Codes.....	85
8.2	Alarms and Diagnosis Controlled by the Gateway	88

9	UPDATING FIRMWARE	90
9.1	Prerequisites	90
9.2	Step-by-Step Instructions for Updating Firmware	91
9.3	Resetting Gateway	93
10	TECHNICAL DATA	94
10.1	Technical Data EU5C-SWD-PROFINET Gateway	94
10.2	PROFINET IO Device (Slave)	97
10.3	Compatibility of SmartWire-DT Devices and Gateway	98
11	ANNEX	100
11.1	List of Figures	100
11.2	List of Tables	102
11.3	Contacts	103

1 Introduction

1.1 About This Manual

This manual describes the Hilscher EU5C-SWD-PROFINET Gateway. Here you will find information on how to install, configure and operate the gateway.

This manual is intended for automation technicians and engineers. Detailed knowledge of PROFINET IO is presumed. In addition, readers should also be familiar with the handling of the SmartWire-DT system.



IMPORTANT!

- To avoid personal injuries or damage of electrical devices, please read this manual carefully before installing and using the EU5C-SWD-PROFINET Gateway.
 - Please first read the *Safety* chapter on page 15 ff.
-

1.1.1 List of Revisions

Index	Date	Chapter	Revisions
1	2012-06-01	All	Created
2	2012-06-25	1.3	<i>Scope of Delivery</i> section substituted by <i>Software Package</i> section.
3	2012-07-16	1.3	Installation program for USB driver added
		1.3.3	<i>Section Notes on Installing the USB driver</i> added

Table 1: List of Revisions

1.1.2 Conventions in this Manual

Notes, operation instructions and results of operation steps are marked as follows:

Notes



Important: <important note>



Note: <note>



<note, where to find further information>

Operation Instructions

1. <instruction>

2. <instruction>

or

➤ <instruction>

Results

↪ <result>

For a description of the labeling of **Safety Messages**, see *Labeling of Safety Messages* section on page 19.

1.2 Versions of Devices, Firmware, Software Tools, Drivers and Device Description File

The hardware revisions and software versions functionally belong together. This means that certain revisions of the hardware of the gateway need certain versions of firmware, software and drivers, in order to function properly.

This section lists the hardware revisions and the versions of the firmware, the configuration software, the drivers and the device description file which functionally belong together and to which all instructions in this manual refer.

Device and Firmware

This manual refers to the following hardware revision and firmware version of the EU5C-SWD-PROFINET Gateway:

Device type name	Protocol	Part number	Hardware revision	Firmware	Firmware version
EU5C-SWD-PROFINET	PROFINET IO	9233.920	3	E030D0U0.nxf	1.0.x.x

Table 2: Reference to Hardware and Firmware

Software Tools

This manual refers to the following software versions:

Software	Manufacturer	Version
Ethernet Device Configuration Tool	Hilscher	1.501
STEP 7	Siemens	5.4 SP5 / 5.5
SWD-Assist	Eaton	1.60

Table 3: Reference to Software Tools

Drivers

This manual refers to the following driver versions:

Driver	File name	Version
USB Driver by Windows ®	usbser.sys	-

Table 4: Reference to Drivers

Device Description File

This manual refers to the following device description file:

Device description file	File name
GSDML for EU5C-SWD-PROFINET Gateway	GSDML-V2.25-Hilscher-EU5C-SWD-201206xx.xml

Table 5: Reference to Device Description File

1.3 Software Package

For the EU5C-SWD-PROFINET Gateway, the software package **EU5C-SWD-SW** (order number 3233.920) is available from Hilscher. The package contains a product DVD and a Mini-USB cable.

You can download the complete product DVD as ZIP file from our website www.hilscher.com under **Products > Gateways** or under **Support > Downloads**.

1.3.1 Contents of the Product DVD

The product DVD includes:

- GSDML Device description file
- Firmware
- Eaton SWD-Assist software
- Wizard for installing the software available on the DVD and for downloading the latest version of the SWD-Assist software from the internet
- Installation program for USB driver (USB driver is needed if the gateway is to be connected to a PC in order to use the Eaton SWD-Assist software)
- Installation program for the Hilscher Ethernet Device Configuration Tool
- Documentation in PDF format
- Installation program for Adobe Reader

The product DVD has the following directories:

Directory	Contents
Documentation	PDF manuals in German and English and installation program for Adobe Reader
Driver	Folder containing installation program (<code>setup.exe</code>) and .INF- and .CAT- files for Windows USB driver.
EDS	GSDML device description file and bitmap files to be imported in PROFINET IO engineering tool
Firmware	Loadable gateway firmware
fscommand	Files for start screen of product DVD
Software	SWD-Assist software Folder: <code>Software\SWD-Assist</code> Wizard for installing the software available on the DVD and for downloading the latest version of the SWD-Assist software from the internet Folder: <code>Software\Setup</code> Installation program for Ethernet Device Configuration Tool Folder: <code>Software\EnDeviceCfg</code>

Table 6: Directory of DVD



Note: You can use the wizard on the product DVD to download updates of the Eaton SWD-Assist software, or you can download SWD-Assist directly from the www.moeller.net website under **Support > Download Center**.
Direct link:

<http://downloadcenter.moeller.net/en/software.a487d8b7-da91-486f-b3ba-a7ca2035db99>

You can download other content stored on the DVD from the Hilscher website www.hilscher.com under **Support > Downloads**.

1.3.2 How to Use the Product DVD

Insert the product DVD into your DVD drive.

If the auto start function of your DVD drive is enabled, the start screen of the DVD automatically opens. You can also start the DVD by double-clicking the `SmartWire.exe` file in the root directory of the DVD.

In the menu of the start screen of the DVD, click **Install Planning and Configuration Tools** to open a wizard for installing the software programs stored on the DVD and for downloading the latest version of the Eaton planning software SWD-Assist from the internet. The wizard provides the following options:

USB driver: installs USB driver for Windows on your PC.

SWD Planning Software SWD-Assist V1.60: installs version 1.60 of the SWD-Assist software (provided on the DVD) on your PC.

Download Center SWD-Assist, manual update check: connects your browser to a web page where you can download the latest version of the SWD-Assist software.

Ethernet Device Scanner/Configuration Tool: installs the Hilscher Ethernet Device Configuration Tool on your PC.

In the menu of the start screen of the DVD, you can also open folders (directories) in which the documentation, the USB driver and the GSDML file are stored.

1.3.3 Notes on Installing the USB Driver

If you intend to use the SWD-Assist software, you should first install the USB driver on your PC before you connect the EU5C-SWD-PROFINET Gateway via USB.

To install the USB driver from the DVD, choose **Install Planning and Configuration Tools** in the DVD menu to open the installation wizard, then select the **USB driver** option. As an alternative, you can double-click the `setup.exe` file in the `Driver\USB\Windows` folder of the DVD. Then simply follow the instructions of the installation routine.



Note: Under Windows XP, the installation process is not yet finished by the setup. The installation process has to be completed in the **Found new Hardware Wizard**, which automatically opens after you have connect the gateway to a PC via USB cable for the first time (see below).

Windows XP

When you connect the gateway via USB for the first time to a PC running under Windows XP, the **Found New Hardware Wizard** opens:

- Answer the question **Can Windows connect to Windows Update...?**, with **No, not this time**. Then click **Next** button.
- If you have already carried out the setup of the USB driver (as recommended), you can ignore the wizard's request to insert a CD or floppy disk. Answer the **What do you want the wizard to do?** question by selecting the **Install the software automatically** option, then click **Next** button.
- After the installation is complete, click **Finish** button.

Windows 7

If you have carried out the setup of the USB driver before first connecting the USB cable (as recommended), then the USB connection is instantly operable under Windows 7.

Uninstall USB Driver

If you want to remove the USB driver from a PC running under Windows XP, choose **Start** menu > **Control Panel** > **Add or Remove Programs**, then select:

Windows Driver Package – Hilscher GmbH (hilusbser) Ports entry. Click **Change/Remove** button to uninstall the driver.

Under Windows 7, choose **Start** menu > **Control Panel** > **Uninstall a program**, then select:

Windows Driver Package – Hilscher GmbH (hilusbser) Ports entry. Click **Uninstall/Change** button to uninstall the driver.

1.4 Documentation Overview

Besides this user manual at hand (path on product DVD: Documentation\english\1.Device Manuals\EU5C-SWD-PROFINET\EU5C-SWD-PROFINET UM 01 EN.pdf), the following documents are also relevant for the user of the EU5C-SWD-PROFINET Gateway:

Title	Contents	Publisher	Document ID	Path on product DVD
<i>SmartWire-DT Units</i>	Information on engineering, installation and programming of the individual SmartWire-DT slaves.	Eaton	05/11 MN05006001Z-EN	Documentation\english\ 2.SmartWire-DT\ MN05006001Z_EN.pdf
<i>SmartWire-DT The System</i>	Information on function, installation, commissioning and diagnostics of the SmartWire-DT system.	Eaton	02/11 MN05006002Z-EN	Documentation\english\ 2.SmartWire-DT\ MN05006002Z_EN.pdf
<i>Ethernet Device Configuration</i>	Operating Instruction Manual of Hilscher Ethernet Device Configuration Tool.	Hilscher	DOC0504020I05 EN	Documentation\english\ 3.Ethernet Device Configuration\ Ethernet Device Configuration OI 05 EN.pdf
<i>PROFINET Installation Guideline for Cabling and Assembly</i>	Information on PROFINET cabling.	PROFIBUS Nutzer-organisation e.V.	Order No: 8.072 Identification: TC2-08-0002	Documentation\english\ 4.PROFINET Guideline Assembly\ PROFINET_Guideline_Assembly_8072_V10_Jan09.pdf
<i>SWD-Assist Online help</i>	Online help for SWD-Assist planning software	Eaton	-	Included in SWD-Assist software

Table 7: Documentation Overview

1.5 Legal Notes

1.5.1 Copyright

© Hilscher 2012, Hilscher Gesellschaft für Systemautomation mbH

All rights reserved.

The images, photographs and texts in the accompanying material (user manual, accompanying texts, documentation, etc.) are protected by German and international copyright law as well as international trade and protection provisions. You are not authorized to duplicate these in whole or in part using technical or mechanical methods (printing, photocopying or other methods), to manipulate or transfer using electronic systems without prior written consent. You are not permitted to make changes to copyright notices, markings, trademarks or ownership declarations. The included diagrams do not take the patent situation into account. The company names and product descriptions included in this document may be trademarks or brands of the respective owners and may be trademarked or patented. Any form of further use requires the explicit consent of the respective rights owner.

1.5.2 Important Notes

The user manual, accompanying texts and the documentation were created for the use of the products by qualified experts, however, errors cannot be ruled out. For this reason, no guarantee can be made and neither juristic responsibility for erroneous information nor any liability can be assumed. Descriptions, accompanying texts and documentation included in the user manual do not present a guarantee nor any information about proper use as stipulated in the contract or a warranted feature. It cannot be ruled out that the user manual, the accompanying texts and the documentation do not correspond exactly to the described features, standards or other data of the delivered product. No warranty or guarantee regarding the correctness or accuracy of the information is assumed.

We reserve the right to change our products and their specification as well as related user manuals, accompanying texts and documentation at all times and without advance notice, without obligation to report the change. Changes will be included in future manuals and do not constitute any obligations. There is no entitlement to revisions of delivered documents. The manual delivered with the product applies.

Hilscher Gesellschaft für Systemautomation mbH is not liable under any circumstances for direct, indirect, incidental or follow-on damage or loss of earnings resulting from the use of the information contained in this publication.

1.5.3 Exclusion of Liability

The software was produced and tested with utmost care by Hilscher Gesellschaft für Systemautomation mbH and is made available as is. No warranty can be assumed for the performance and flawlessness of the software for all usage conditions and cases and for the results produced when utilized by the user. Liability for any damages that may result from the use of the hardware or software or related documents, is limited to cases of intent or grossly negligent violation of significant contractual obligations. Indemnity claims for the violation of significant contractual obligations are limited to damages that are foreseeable and typical for this type of contract.

It is strictly prohibited to use the software in the following areas:

- for military purposes or in weapon systems;
- for the design, construction, maintenance or operation of nuclear facilities;
- in air traffic control systems, air traffic or air traffic communication systems;
- in life support systems;
- in systems in which failures in the software could lead to personal injury or injuries leading to death.

We inform you that the software was not developed for use in dangerous environments requiring fail-proof control mechanisms. Use of the software in such an environment occurs at your own risk. No liability is assumed for damages or losses due to unauthorized use.

1.5.4 Warranty

Although the hardware and software was developed with utmost care and tested intensively, Hilscher Gesellschaft für Systemautomation mbH does not guarantee its suitability for any purpose not confirmed in writing. It cannot be guaranteed that the hardware and software will meet your requirements, that the use of the software operates without interruption and that the software is free of errors. No guarantee is made regarding infringements, violations of patents, rights of ownership or the freedom from interference by third parties. No additional guarantees or assurances are made regarding marketability, freedom of defect of title, integration or usability for certain purposes unless they are required in accordance with the law and cannot be limited. Warranty claims are limited to the right to claim rectification.

1.5.5 Export Regulations

The delivered product (including the technical data) is subject to export or import laws as well as the associated regulations of different countries, in particular those of Germany and the USA. The software may not be exported to countries where this is prohibited by the United States Export Administration Act and its additional provisions. You are obligated to comply with the regulations at your personal responsibility. We wish to inform you that you may require permission from state authorities to export, re-export or import the product.

1.5.6 Registered Trademarks

SmartWire-DT is a registered trademark of Eaton Industries GmbH, Bonn.

Windows[®] 2000, Windows[®] XP, Windows[®] Vista and Windows[®] 7 are registered trademarks of the Microsoft Corporation.

S7 and STEP 7 are registered trademarks of Siemens AG.

Adobe-Acrobat[®] is a registered trademark of the Adobe Systems Incorporated.

PROFINET is a registered trademark of PROFIBUS International, Karlsruhe.

All other mentioned trademarks are property of their respective legal owners.

2 Safety

2.1 General Note

The user manual, all accompanying texts and the documentation are written for the use of the products by educated personnel. When using the products, all safety instructions, property damage messages and all valid legal regulations have to be observed. Technical knowledge is presumed. The user has to assure that all legal regulations are obeyed.

2.2 Intended Use

The purpose of the EU5C-SWD-PROFINET Gateway described in this user manual is to create a connection between SmartWire-DT slaves and an overriding PROFINET IO controller (master device).

2.3 Personnel Qualification

The EU5C-SWD-PROFINET Gateway must be installed, configured and removed by qualified personnel only. Job-specific technical skills for people professionally working with electricity must be present concerning the following issues:

- Safety and health at work
- Mounting and connecting of electrical equipment
- Measurement and analysis of electrical functions and systems
- Evaluation of the safety of electrical systems and equipment
- Installing and configuring IT systems

2.4 References Safety

- [S1] ANSI Z535.6-2006 American National Standard for Product Safety Information in Product Manuals, Instructions, and Other Collateral Materials
- [S2] IEC 60950-1, Information technology equipment - Safety - Part 1: General requirements, (IEC 60950-1:2005, modified); German Edition EN 60950-1:2006
- [S3] EN 61340-5-1 and EN 61340-5-2 as well as IEC 61340-5-1 and IEC 61340-5-2

2.5 Safety Instructions to Avoid Personal Injury

To ensure your own personal safety and to avoid personal injury, you must read, understand and follow the following safety instructions in this manual and all warning messages, before you install and operate the EU5C-SWD-PROFINET Gateway.

2.5.1 Electrical Shock Hazard

Take care of the following safety measures before installing or uninstalling the gateway:

- First disconnect the power plug of the device.
- Make sure that the device is disconnected from the power supply.
- Cover or enclose neighboring units that are live.

Devices that are designed for mounting in housings or control cabinets must only be operated and controlled after they have been installed with the housing closed. Desktop or portable units must only be operated and controlled in enclosed housings.

2.5.2 Danger of Unintended Starting Up of Machines

- Install automation devices and related operating elements in such a way that they are well protected against unintentional operation.
- Emergency stop devices complying with IEC/EN 60204-1 must be effective in all operating modes of the automation devices. Unlatching the emergency-stop devices must not cause restart.
- You must take safety precautions (emergency switching off) in the external circuitry of the EU5C-SWD-PROFINET and any power modules type EU5C-SWD-PF1-1 or EU5C-SWDPF2-1 that are used. To do so, plan to switch off the power supply to the contactor coils AUX.
- Measures should be taken to ensure the proper restart of programs interrupted after a voltage dip or failure. This should not cause dangerous operating states even for a short time. If necessary, emergency stop devices should be implemented.
- Wherever faults in the automation system may cause damage to persons or property, external measures must be implemented to ensure a safe operating state in the event of a fault or malfunction (for example, by means of separate limit switches, mechanical interlocks etc.).

2.6 Safety Instructions to Avoid Property Damage

To avoid damage to your EU5C-SWD-PROFINET Gateway or your communication system, you must read, understand and follow the following safety instructions and all safety instructions and warnings in this manual concerning property damage, before you install and operate the gateway.

2.6.1 General Safety Instructions Concerning Supply Voltage

- In safety-relevant applications the power supply providing power to the SmartWire-DT system must feature a PELV power feed module (protective extra low voltage).
- Switch off the power supply, if you are reconnecting slaves in the SmartWire-DT system or reconnecting the ribbon cable connection. Otherwise the SmartWire-DT slaves can be destroyed!
- The gateway has protection against polarity reversal for the 24-V-DC-POW supply. However, if the gateway is connected via the serial interface to an earthed device (for example to a PC), the gateway can be destroyed, if the polarity of the power supply is reversed!
- The functional earth (FE) must be connected to the protective earth (PE) or to the potential equalization. The system installer is responsible for implementing this connection.
- Connecting cables and signal lines should be installed so that inductive or capacitive interference does not impair the automation functions.
- Suitable safety hardware and software measures should be implemented for the I/O interface so that a line or wire breakage on the signal side does not result in undefined states in the automation devices.

2.6.2 Device Destruction by Exceeding Allowed Supply Voltage

The EU5C-SWD-PROFINET Gateway must only be operated with the specified supply voltage.

- Make sure that the limits of the allowed range for the supply voltage are not exceeded. A supply voltage above the upper limit can cause severe damage of the gateway!
- A supply voltage below the lower limit can cause malfunction of the gateway!
- Ensure a reliable electrical isolation of the low voltage for the 24 volt supply. Only use power supply units complying with IEC 60364-4-41 (VDE 0100 Part 410) or HD 384.4.41 S2.

The allowed range for the supply voltage is indicated in section *Technical Data* on page 94.

2.6.3 Electrostatic Sensitive Device

The EU5C-SWD-PROFINET Gateway is sensitive to electrostatic discharge, which can cause internal damage and affect its normal operation. Therefore adhere to the necessary safety precautions for components that are vulnerable to electrostatic discharge when you install or remove the gateway. Follow the guidelines listed hereafter when you handle the gateway:

- Touch a grounded object to discharge potential static before you handle the gateway.
- Wear an approved grounding wriststrap.
- If possible, use a static-safe workstation.
- When not in use, store the device in appropriate static-safe packaging.

2.7 Labeling of Safety Messages

- The **Section Safety Messages** at the beginning of a chapter are pinpointed particularly. They are highlighted by a specific safety symbol and a signal word according to the degree of endangerment. In the safety message, the nature of the hazard is indicated.
- The **Integrated Safety Messages** embedded in operating instructions are highlighted by a signal word according to the degree of endangerment and possibly by a safety symbol. In the safety message, the nature of the hazard is indicated.



Safety symbol	Sort of warning or principle
	Warning of personal injury or property damage
	Warning of damages by electrostatic discharge
	Principle: Disconnect the power plug

Table 8: Safety Symbols and Sort of Warning or Principle





Signal word	Meaning	Meaning USA
	Indicates a direct hazard with high risk, which will have as consequence death or grievous bodily harm if it is not avoided.	Indicates a hazardous situation which, if not avoided, will result in death or serious injury.
	Indicates a possible hazard with medium risk, which will have as consequence death or (grievous) bodily harm if it is not avoided.	Indicates a hazardous situation which, if not avoided, could result in death or serious injury.
	Indicates a minor hazard with medium risk, which could have as consequence personal injury, if it is not avoided.	Indicates a hazardous situation which, if not avoided, may result in minor or moderate injury.
	Indicates a property damage message.	Indicates a property damage message.
Note	Indicates an important note in the manual.	Indicates an important note in the manual.

Table 9: Signal Words

In this document, the safety instructions and property damage messages are designed according both to the internationally used safety conventions as well as to the ANSI Z535 standard.

3 Descriptions and Requirements

3.1 Device Description EU5C-SWD-PROFINET Gateway

3.1.1 Overview

The EU5C-SWD-PROFINET Gateway integrates a SmartWire-DT network into a PROFINET network. The Gateway creates a data connection between the participants (the slaves) of the subordinate SmartWire-DT network and the controller (the master or PLC) of the superordinate PROFINET IO network.

The gateway acts as master in the SmartWire-DT network, and as modular IO Device (slave) in the PROFINET network. It thereby presents each connected SmartWire-DT participant as individual module to the PROFINET IO Controller.

The cyclic process data is exchanged transparently between both networks. 1000 Bytes of process input/output data can in sum be exchanged with up to 99 SmartWire-DT participants (slaves).

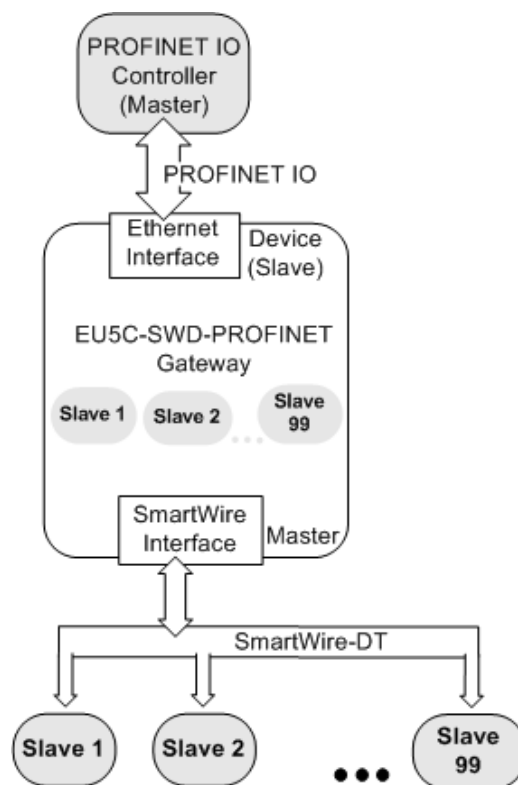

Figure 1: Data Flow EU5C-SWD-PROFINET Gateway

3.1.2 Configuration

The EU5C-SWD-PROFINET Gateway is easily commissioned by an automated configuration function: On pushing the configuration button on the front of the gateway, the gateway scans the current SmartWire-DT network configuration, the so-called actual configuration. It then stores the actual configuration as target configuration zero voltage-safe in the device, thus making the target configuration available for a comparison of actual and targeted SmartWire-DT configuration, which takes place each time the gateway is being switched on.

When the gateway is switched on after a target configuration has already been stored, the gateway automatically rescans the connected actual configuration and checks it against the target configuration. It then gets ready for PROFINET IO and waits for the PROFINET configuration. The gateway checks the project configuration, which it receives from the PROFINET IO controller, against the target configuration. Discrepancies between target and actual, or between target and project configurations are reported by the gateway via PROFINET-Diagnosis.

The gateway is commissioned in PROFINET by using a PROFINET IO controller engineering tool and a GSDML device description file, which is to be imported into engineering tool. The GSDML file of the gateway is stored in the `EDS\EU5C-SWD-PROFINET` directory of the product DVD, which is included in the scope of delivery. The file contains all configuration data and all possible SmartWire-DT slaves as I/O modules.



Note: The GSDML device description file contains only I/O information for SmartWire-DT slaves which were listed as sales products at the time of creation of the file.

Eaton SWD-Assist planning software

In principle, you can build-up and configure a SmartWire-DT network without any software tools. However, it is recommended to use the SWD-Assist software to plan, dimension and document the SmartWire-DT network. In SWD-Assist, a project specific GSDML file can be created and exported. Using this file gives you the benefit of finding the I/O modules of the SmartWire-DT slaves already preconfigured in your PROFINET controller engineering tool.



For further information, please refer to the SWD-Assist online help.



Note: You will find the Eaton SWD-Assist software on the product DVD, which is included in the EU5C-SWD-SW software package (order number 3233.920) available from Hilscher.

You can use the wizard on the product DVD to download updates of the Eaton SWD-Assist software, or you can download SWD-Assist directly from the www.moeller.net website under **Support > Download Center**.
Direct link:

<http://downloadcenter.moeller.net/en/software.a487d8b7-da91-486f-b3ba-a7ca2035db99>

3.1.3 Interfaces

The gateway features a SmartWire-DT interface (plug, 8-pole), a 2-port switch Ethernet interface (RJ45) and a Mini-USB interface. Via the Mini-USB interface, the gateway can communicate with the SWD-Assist software.

3.1.4 Diagnosis

The gateway can be diagnosed by connecting the SWD-Assist software to the Mini-USB interface. For further information, please refer to the SWD-Assist online help.

The PROFINET IO protocol also provides diagnostic functions. For further information, see section *Alarms and Diagnosis Controlled by the Gateway* on page 88.

3.1.5 Firmware Update

The EU5C-SWD-PROFINET Gateway is shipped with its most recent firmware already loaded. If an update of the firmware should be necessary, the update can be done by using an ordinary web browser.

A web server embedded in the gateway provides a special web page for updating the firmware, which can be accessed by the Ethernet interface of the gateway. For more details, please refer to the *Updating Firmware* chapter on page 90 ff.

3.2 Prerequisites for Operation

The following prerequisites must be fulfilled to operate the EU5C-SWD-PROFINET Gateway:

3.2.1 Network System

- SmartWire-DT network with maximum number of up to 99 participants/stations/slaves and maximum extension of up to 600 meters.
- PROFINET IO network with PROFINET IO Controller (master) respectively PLC. Maximum cable length for one segment (cable between two switches) is 100 meters.

3.2.2 Power Supply



NOTICE

In safety-relevant applications the power supply providing power for the SmartWire-DT system must feature a PELV power feed module (protective extra low voltage).



NOTICE

Ensure a reliable electrical isolation of the low voltage for the 24 volt supply. Only use power supply units complying with IEC 60364-4-41 (VDE 0100 Part 410) or HD 384.4.41 S2.



NOTICE

You must take safety precautions (emergency switching off) in the external circuitry of the EU5C-SWD-PROFINET and any power modules type EU5C-SWD-PF1-1 or EU5C-SWDPF2-1 that are used. To do so, plan to switch off the power supply to the contactor coils **AUX**.



Important!

Please take into consideration the total power consumption of your SmartWire-DT network and, if necessary, plan for an additional feeder module EU5C-SWD-PF2.

You can find information on the power consumption in the operating manuals of the SmartWire-DT devices.

3.2.2.1 POW Power Connection

A Power supply of 24 V DC for the coupling unit and for the Smart-Wire-DT slave electronics is needed at the connection **POW**.

On the SmartWire-DT gateway, connect the **POW** and **AUX** supply voltages via separate miniature circuit-breakers or fuses:

Miniature circuit-breaker 24 V DC for POW

- Cable protection in accordance with **DIN VDE 0641** Part 11, IEC/EN 60898:
Miniature circuit-breaker 24 V DC rated operational current 3 A; trip types **C** or Fuse 3 A, utilization class gL/gG
- Cable protection for cable AWG 24 in accordance with **UL 508** und CSA-22.2 No. 14:
Miniature circuit-breaker 24 V DC rated operational current 3 A; Tripping characteristics **C** or Fuse 3 A

3.2.2.2 AUX Power Connection

If any switching devices are also to be connected, for example via the DIL-SWD-32-001/002 SmartWire-DT slaves, a 24 V DC supply will also be required at the **AUX** power connection. This provides the supply for activating the contactor coils. This supply must be protected by an automatic circuit-breaker (3A gG/gl or 3 A miniature circuit-breaker with a Z characteristic).

If switching devices with an activation power greater than 3 A are connected, an additional feeder module EU5C-SWD-PF1 or EU5C-SWD-PF2 must be used.

On the SmartWire-DT gateway, connect the **POW** and **AUX** supply voltages via separate miniature circuit-breakers or fuses:

Miniature circuit-breaker 24 V DC for AUX

- Cable protection in accordance with **DIN VDE 0641** Part 11, IEC/EN 60898:
Miniature circuit-breaker 24 V DC rated operational current 3 A; trip type **Z** or Fuse 3 A, utilization class gL/gG
- Cable protection for cable AWG 24 in accordance with **UL 508** und CSA-22.2 No. 14:
Miniature circuit-breaker 24 V DC rated operational current 2 A; Tripping characteristics **Z** or Fuse 2 A

4 Device Picture, Connectors and LEDs

4.1 Device Picture

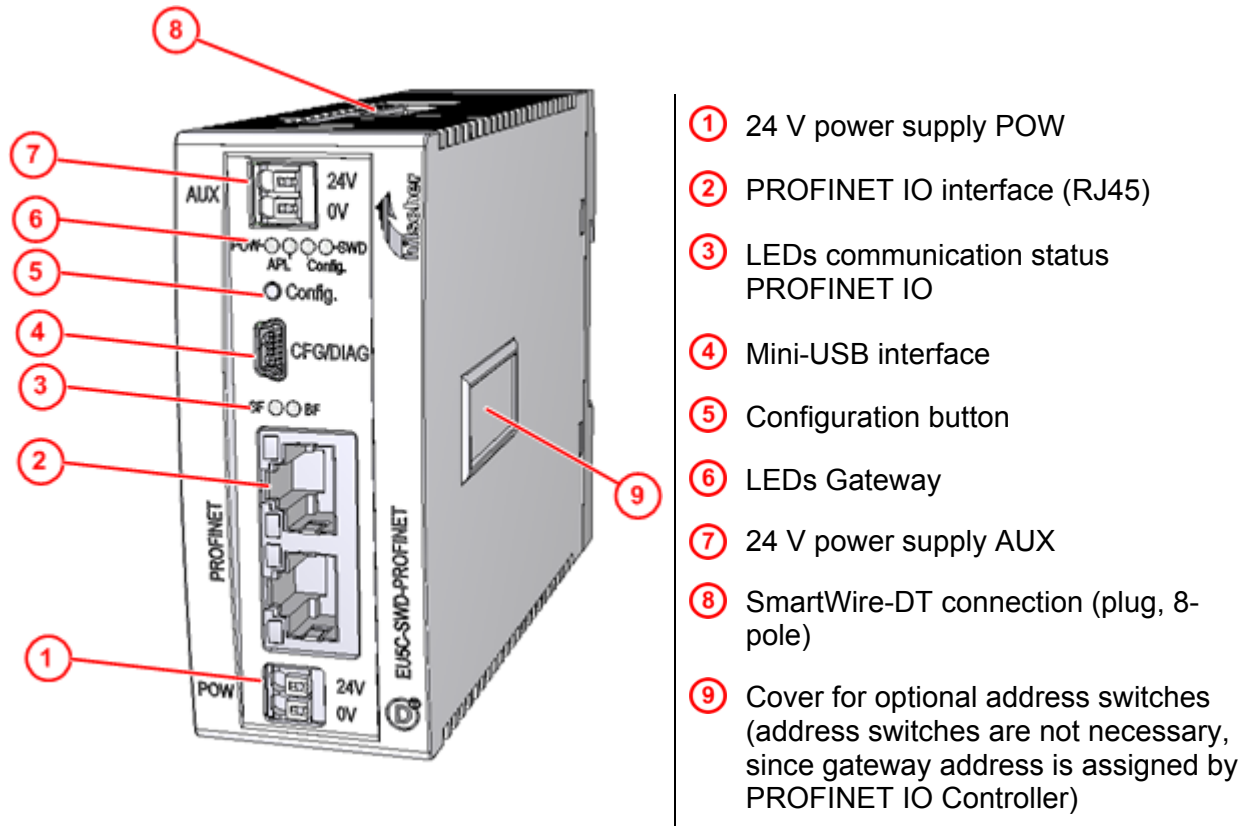
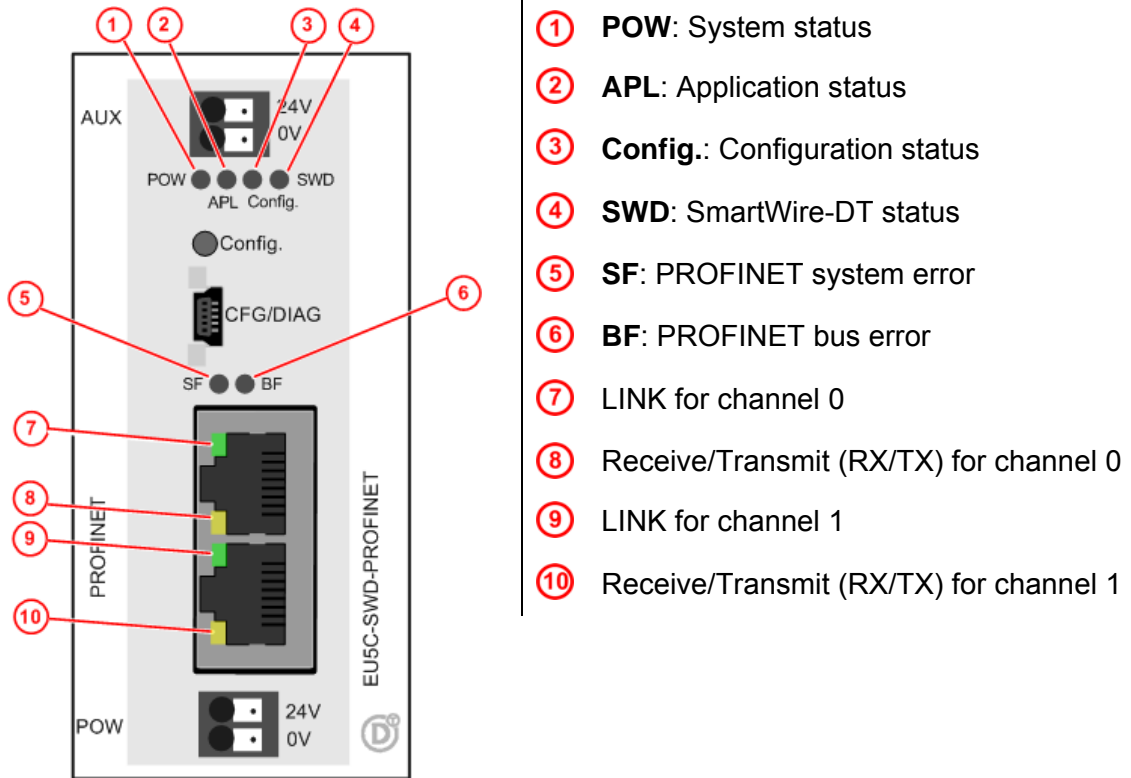

Figure 2: Front View EU5C-SWD-PROFINET Gateway

4.2 Positions and Meaning of the LEDs

4.2.1 Positions of the LEDs



- ① **POW**: System status
- ② **APL**: Application status
- ③ **Config.:** Configuration status
- ④ **SWD**: SmartWire-DT status
- ⑤ **SF**: PROFINET system error
- ⑥ **BF**: PROFINET bus error
- ⑦ LINK for channel 0
- ⑧ Receive/Transmit (RX/TX) for channel 0
- ⑨ LINK for channel 1
- ⑩ Receive/Transmit (RX/TX) for channel 1

Figure 3: LEDs EU5C-SWD-PROFINET Gateway

4.2.2 Descriptions of the LEDs















LED	Color	State	Meaning
POW System status Number in picture: ①	Duo-LED yellow/green		
	 (yellow)	On	Operating system is running, firmware is started.
	 (green/yellow)	Flashing	Bootloader mode active, firmware not loaded.
	 (green)	On	Firmware backup active.
	 (off)	Off	Power supply for device is missing or hardware defect.
APL Application status Number in picture: ②	Duo-LED red/green		
	 (green)	On	The communication on PROFINET and SmartWire-DT is in cyclic data exchange and the gateway function is executed.
	 (green)	Flashing 2 s off, 0.5 s on	Gateway is initialized, but the communication on PROFINET is not in cyclic data exchange.
	 (green)	Flashing 2 s off, 0.5 s on, 0.5 s off, 0.5 s on	Gateway is initialized, but the communication on SmartWire-DT is not in cyclic data exchange.
	 (red)	Flashing 2 s off, 0.5 s on	Gateway is initialized, but the configuration for the communication protocol on PROFINET is missing or in error.
	 (red)	Flashing 2 s off, 0.5 s on, 0.5 s off, 0.5 s on	Gateway is initialized, but the configuration for the communication protocol on SmartWire-DT is missing or in error.
	 (red)	On	Gateway has detected an error during the initialization: Missing configuration, error in configuration or internal error.
Config. Configuration status Number in picture: ③	Duo-LED red/green		
	 (green)	On	The planned configuration complies with the gateway target configuration. Data exchange between Gateway and PLC via PROFINET takes place.
	 (green)	Flashing	The planned configuration does not comply with the gateway target configuration, but is compatible with it. Data exchange between gateway and PLC via PROFINET takes place.
	 (red)	On	The planned configuration and the gateway target configuration are not compatible. No data exchange between gateway and PLC via PROFINET.
	 (off)	Off	No communication with the PROFINET IO controller or the gateway does not contain a project configuration.

Table 10: Description of the LEDs (1)















LED	Color	State	Meaning
SWD Status SmartWire-DT Number in picture: ④	Duo-LED red/green/orange (orange = red/green at same time)		
	 (green)	On	The current actual configuration complies with the gateway target configuration. Data exchange between gateway and SmartWire-DT slaves takes place.
	 (red)	Flashing	A necessary SmartWire-DT slave is missing or the gateway target configuration does not comply with the actual configuration. No data exchange between gateway and SmartWire-DT slaves.
	 (green)	Flashing	Slave addressing is active (after power On or the download of a planned configuration with empty modules). No data exchange between gateway and SmartWire-DT slaves.
	 (red)	On	Short-circuit on the 15 V power supply or no SmartWire-DT slave is connected. No data exchange between gateway and SmartWire-DT slaves.
	 (orange)	Flashing	After having pressed the configuration button: The gateway reads the current actual configuration and stores it as target configuration.
SF PROFINET System Error Number in picture: ⑤	Duo-LED red/green		
	 (red)	On	Watchdog timeout; channel-, generic or extended diagnosis present; system error.
	 (red)	Flashing cyclically at 2 Hz (for 3 sec.)	DCP signal service is initiated via the bus.
	 (off)	Off	No error.
BF PROFINET Bus Error Number in picture: ⑥	Duo-LED red/green		
	 (red)	On	No configuration; or low speed physical link; or no physical link.
	 (red)	Flashing cyclically at 2 Hz	No data exchange.
	 (off)	Off	No error.
LINK/RJ45 Ch0 & Ch1 Numbers in picture: ⑦ & ⑨	LED green		
	 (green)	On	Gateway has connection to Ethernet.
	 (off)	Off	Gateway has no connection to Ethernet.
RX/TX/RJ45 Ch0 & Ch1 Numbers in picture: ⑧ & ⑩	LED yellow		
	 (yellow)	Steady on or flashing	Gateway sends/receives Ethernet frames.

Table 11: Description of the LEDs (2)

4.3 Pinning PROFINET IO Interface

The following picture shows the pinning of the PROFINET IO interface of the EU5C-SWD-PROFINET Gateway:

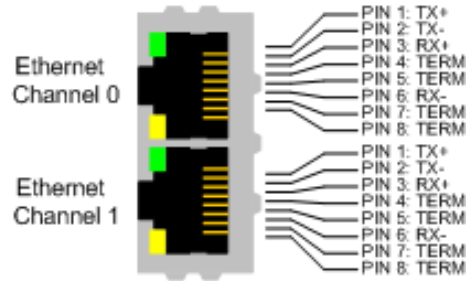

Figure 4: Pinning of the Ethernet Interface (RJ45)

Pin	Signal	Description
1	TX +	Transmit Data +
2	TX –	Transmit Data –
3	RX +	Receive Data +
4	TERM	Bob Smith Termination
5	TERM	
6	RX –	Receive Data –
7	TERM	Bob Smith-Termination
8	TERM	

Tabelle 1: Ethernet Interface Channel 0 and Channel 1 Pin Assignment (RJ45)



Note: Auto-Crossover function is supported by the gateway.

5 Getting Started

The following table provides an overview of the steps necessary for installing and commissioning the EU5C-SWD-PROFINET Gateway.



Note: The gateway is shipped with its firmware already loaded. For information on how to update the firmware of the gateway, please refer to *Updating Firmware* chapter on page 90.

#	Step	For details refer to
1	Install gateway	Chapter <i>Installing EU5C-SWD-PROFINET Gateway</i> on page 31 ff
1.1	Take safety precautions	Section <i>Safety Messages</i> on page 31
1.2	Mount gateway onto top hat rail	Section <i>Mounting Gateway onto Top Hat Rail</i> on page 32
1.3	Connect gateway to power supply	Section <i>Connecting Gateway to Power Supply</i> on page 35
1.4	Connect gateway to SmartWire-DT network	Section <i>Connecting SmartWire-DT</i> on page 37
1.5	Connect gateway to PROFINET IO network	Section <i>Connecting PROFINET IO</i> on page 38
2	Commission gateway	Chapter <i>Commissioning EU5C-SWD-PROFINET Gateway</i> on page 40 ff
2.1	Configure SmartWire-DT network in gateway	Section <i>Configuring SmartWire-DT network in Gateway</i> on page 40
2.2	Configure a PROFINET IO project for gateway	Section <i>Configuring Gateway in PROFINET IO Network</i> on page 43
2.2.1	Import GSDML device description file in programming tool	Section <i>GSDML Device Description File</i> on page 43 Example for STEP 7: Section <i>Import GSDML Device Description File</i> on page 48
2.2.2	Configure gateway in PROFINET IO project	Example for STEP 7: Section <i>Step-by-Step Instructions for Configuring Gateway with STEP 7</i> on page 46
2.2.3	Load PROFINET IO configuration to Controller/PLC	Example for STEP 7: Section <i>Step-by-Step Instructions for Loading PROFINET IO Configuration to S7-300 PLC</i> on page 67
2.3	Program Controller/PLC	Example for STEP 7: Section <i>Step-by-Step Instructions for Programming in STEP 7: Display I/O Data</i> on page 71

Table 12: Getting Started

6 Installing EU5C-SWD-PROFINET Gateway

6.1 Safety Messages



WARNING

Please observe the following safety messages when you install and handle the gateway!

- First disconnect the power plug of the device.
 - Make sure that the power supply is off at the device.
 - Cover or enclose neighboring units that are live.
-



NOTICE**Electrostatic Sensitive Device**

The gateway is sensitive to electrostatic discharge, which can cause internal damage and affect its normal operation. Therefore adhere to the necessary safety precautions for components that are vulnerable to electrostatic discharge, when you install or handle the gateway.

- Do not touch the metal pins of the connectors of the gateway.
 - Touch a grounded object to discharge potential static.
 - Wear an approved grounding wriststrap.
 - If available, use a static-safe workstation.
 - When not in use, store the device in an appropriate static-safe packaging.
-

6.2 Mounting Gateway

For mounting the EU5C-SWD-PROFINET Gateway onto a top hat rail, no tools are required. The back of the gateway **1** carries a spring-fitted bolt **2**, by which the gateway can be clamped to the rail **3**.

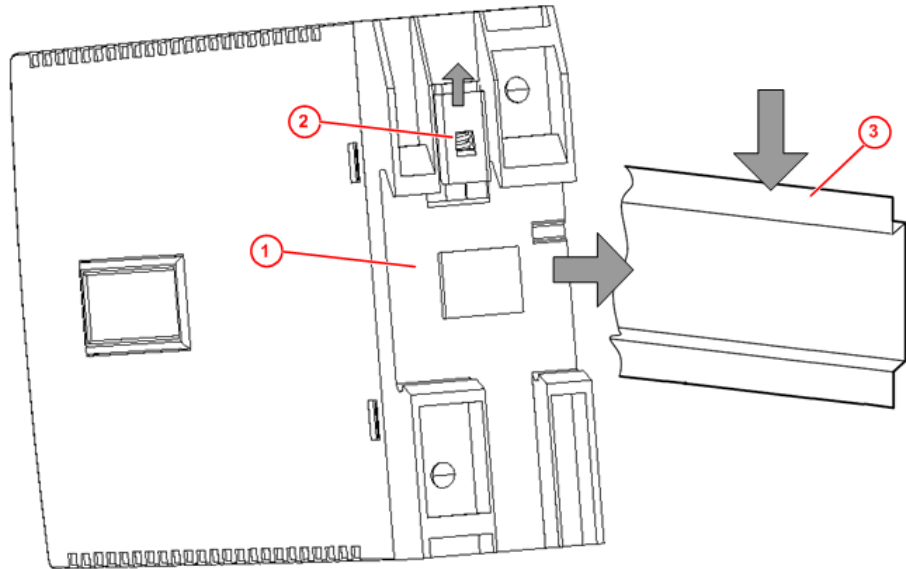

Figure 5: Mounting Principle of the Gateway

6.2.1 Mounting Gateway onto Top Hat Rail

To mount the gateway onto the top hat rail, proceed as follows:



- Make sure that the gateway is disconnected from any power supply.
- Cover or enclose neighboring units that are live.

- Tilt the gateway slightly and hook it into the upper railing from above, thereby pushing down the gateway with slight force, in order to overcome the resistance of the spring in the bolt.

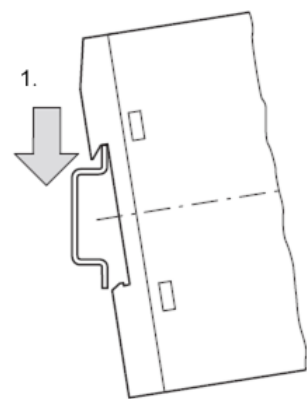

Figure 6: Hook Gateway to Upper Railing

- Keep on pushing the gateway downwards and tilt it back into vertical position, thereby hooking the gateway into the lower railing.

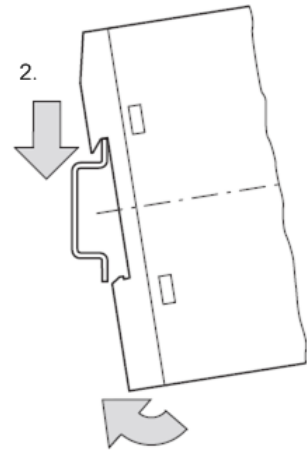

Figure 7: Hook Gateway to Lower Railing

- Let go of the gateway. The spring inside the bolt automatically pushes the gateway upwards into the railings, thereby fixing the gateway to the top hat rail.

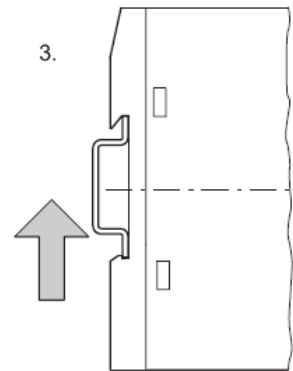

Figure 8: Gateway is Clamped to Top Hat Rail

6.2.2 Removing Gateway from Top Hat Rail

To remove the gateway from the top hat rail, proceed as follows:



- First disconnect the power plugs from the gateway.
- Make sure that the power supply is off at the gateway.
- Cover or enclose neighboring units that are live.

- Push down the gateway with slight force (to overcome the resistance of the spring in the bolt), then unhook the gateway first from the lower railing and then from the upper railing.

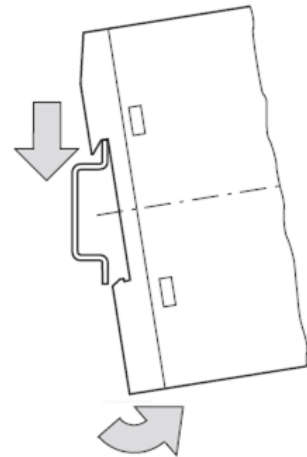

Figure 9: Unhook Gateway

6.3 Connecting Gateway to Power Supply

**NOTICE**

In safety-relevant applications, the power supply providing power to the SmartWire-DT system must feature a PELV power feed module (protective extra low voltage).

**NOTICE**

You must take safety precautions (emergency switching off) in the external circuitry of the EU5C-SWD-PROFINET Gateway and any power modules type EU5C-SWD-PF1-1 or EU5C-SWDPF2-1 that are used. To do so, plan to switch off the power supply to the contactor coils **AUX**.

**Important!**

Please take into consideration the total power consumption of your SmartWire-DT network and, if necessary, plan for an additional feeder module EU5C-SWD-PF2.

You can find information on the power consumption in the operating manuals of the SmartWire-DT devices.

- Connect the 24 V DC voltage to the **POW** terminals on the front side of the gateway. The **POW** connection provides the voltage for the gateway itself and for the SmartWire-DT slave electronics.



Note: For the 15 V supply of the SmartWire-DT slaves, the gateway contains an additional power feed module with an amperage of 0.7 A.

- If necessary, connect the 24 V DC voltage for the contactor coils to the **AUX** terminals on the front side of the gateway.

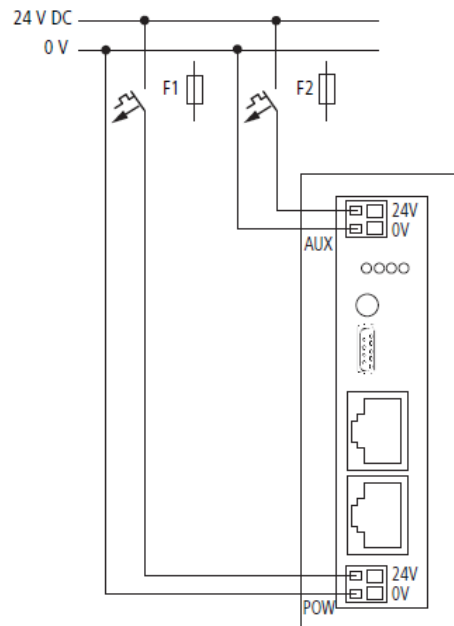

Figure 10: Gateway Power Supply



Note: The **AUX** supply is required if any switching devices are also to be connected, for example, via the DIL-SWD-32-001/002 SmartWire-DT slaves. The **AUX** connection provides the supply for activating the contactor coils.

This supply must be protected by an automatic circuit-breaker (3A gG/gI or 3 A miniature circuit-breaker with a Z characteristic).

If switching devices with an activation power greater than 3 A are connected, an additional feeder module EU5C-SWD-PF1 or EU5C-SWD-PF2 must be used.

Potential conditions between the components

The entire SmartWire-DT system operates on a common supply voltage. Provide a common star point for the earth wiring. In this way, the various slaves in the SmartWire-DT system will not be electrically isolated from one another.

The PROFINET network and the SmartWire-DT system are electrically isolated from one another.

6.4 Connecting SmartWire-DT

- Connect the SmartWire-DT network to the gateway. To do so, use the SmartWire-DT cable SWD4-100LF8-24 and the SWD4-8MF2 relevant blade terminal or prefabricated cables of type SWD4-(3/5/10)F8-24-2S.

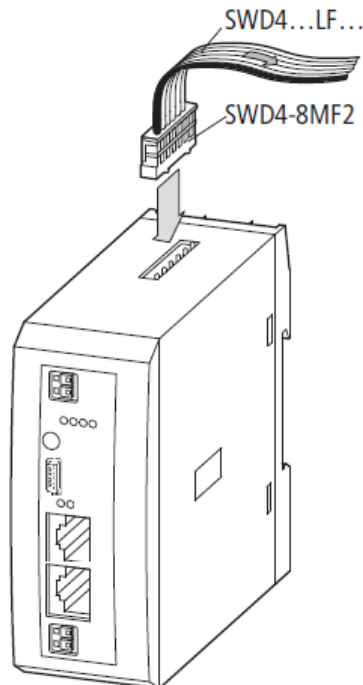

Figure 11: Connecting SmartWire-DT to Gateway



NOTICE

Switch off the power supply, if you are reconnecting slaves in the SmartWire-DT system or reconnecting the ribbon cable connection. Otherwise the SmartWire-DT slaves can be destroyed!



Note: Detailed instructions on adapting the SmartWire-DT external device plug (SWD4-8SF2-5) to the 8 pole Smart-Wire-DT cable are provided in chapter *Fitting external device plugs SWD4-8SF2-5* of the manual *SmartWire-DT – The System, MN05006002Z-EN* (previously AWB2723-1617en).

6.5 Connecting PROFINET IO

- Connect the RJ45 plug of the PROFINET IO cable to one of the Ethernet connectors on the gateway.

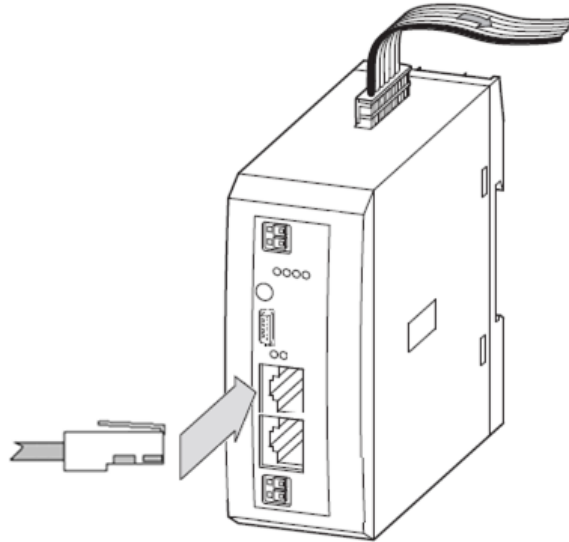

Figure 12: Connecting PROFINET IO to Gateway



Important!

Please observe the following notes on PROFINET IO cabling:

- Do not use hubs.
- Use switches only if the switch supports “Priority Tagging” and LLDP (100 MBit/s, Full Duplex).
- Maximum cable length in a segment is 100 meters.

Please also observe the following note on the cabling of the PROFINET IO Controller:

- Connect only ports with each other which have different cross-over settings. Otherwise, a connection between the devices can not be established. If the port settings of the PROFINET IO Controller are not set to AUTO, then Port0 is switched uncrossed and Port1 crossed.

6.6 EMC-Conformant Wiring of the Network

Undesired faults can occur on the bus due to electromagnetic interference. This can be minimized beforehand by the implementation of suitable EMC measures. These include:

- EMC-conformant system configuration,
- EMC compliant cable routing,
- Measures that do not allow the occurrence of large differences in potential and
- correct installation of the PROFINET system (cables, connection of the bus connectors, etc.)

The effects of electromagnetic interference can be significantly reduced by fitting a shield.



For detailed information on this, please refer to the *PROFINET Installation Guideline for Cabling and Assembly*, published by the PROFIBUS Nutzerorganisation e.V., Order No: 8.072.

7 Commissioning EU5C-SWD-PROFINET Gateway

Before switching on, check whether the power supply for the gateway is connected correctly. The configuration and installation of the SmartWire-DT network must also have been carried out correctly (with all slaves connected).

Commissioning takes place in several steps:

1. Putting the SmartWire-DT network into operation.
2. Create a connection to the PROFINET IO network.
3. Configure PROFINET IO network and load configuration to PLC (PROFINET IO Controller).
4. Write code for controller program and load it to PLC (PROFINET IO Controller).



WARNING

Danger of lethal injuries by unexpected starting up of motors or machinery!

If you have already integrated devices into a system, secure the operating range of any connected parts of the system against access, so that nobody is endangered by motors or machinery starting up unexpectedly.

7.1 Configuring SmartWire-DT network in Gateway

Before the gateway can exchange data with the PLC, a valid SmartWire-DT network configuration (a so-called gateway target configuration) has to be stored in the gateway.

This is compared with the current configuration (actual configuration) each time the gateway is restarted. If the gateway ascertains in this process that a SmartWire-DT slave cannot be reached or a wrong slave type is determined, the SmartWire-DT network will not go into operation (to be precise, this is dependent on the network configuration).

Reading of the SmartWire-DT network configuration takes place by pressing the configuration button on the gateway (for the position of the configuration button, see figure *Front View EU5C-SWD-PROFINET Gateway* on page 25). All SmartWire-DT slaves are re-addressed in ascending order in the process.

This process may only take place in the case of:

- initial commissioning,
- the replacement of a defective slave or
- a change to the configuration.

If a SmartWire-DT slave has failed, the SmartWire-DT network can still be operated with the remaining slaves, depending on the configuration setting (even after a repeat power up of the gateway). The failure is reported to the application.

**Important!**

If there is a faulty configuration and the configuration button is pressed, only the slaves up to the failed device are addressed and stored. Use of the remaining slaves is not possible until the defective slave has been replaced and the configuration has been read in again by pressing the configuration button.

7.1.1 Reading the SmartWire-DT Configuration

If you startup the gateway for the first time, or if you have replaced a SmartWire-DT slave or changed the setup of the SmartWire-DT network in some other way, you have to initiate a reading of the SmartWire-DT configuration.

Prerequisites for reading the configuration are:

- All SmartWire-DT slaves are connected to the SmartWire-DT line.
- The SmartWire-DT network is connected to the gateway.
- The voltage POW is applied to the coupling unit and the power LED POW is on.
- The voltage AUX is applied (if necessary).
- The SmartWire-DT status LEDs of the SmartWire-DT slaves are on or are flashing.



Note: Disconnect the PROFINET IO network from the gateway by removing the RJ45 plug from the Ethernet interface of the gateway, before pressing the configuration button.

- Press the configuration button on the gateway for at least two seconds (for the position of the configuration button, see figure *Front View EU5C-SWD-PROFINET Gateway* on page 25).
Take care to push the button properly. You have to feel and overcome a slight resistance when pushing the button into the gateway, otherwise the button won't trigger.
- ↻ The SmartWire status LED on the gateway begins to flash orange. The SmartWire-DT status LEDs on the SmartWire-DT slaves also flash.
- ↻ All slaves are addressed in sequence, the complete configuration is stored retentively as gateway target configuration.
- ↻ The gateway then restarts.

7.1.2 Switching On Gateway When Target Configuration Is Stored

If a configuration is stored in the gateway, each time the supply voltage is switched on, it is checked whether the slaves actually found on the network comply with the stored gateway target configuration.

The result of the check is indicated by the SmartWire-DT status LED on the gateway (for the position of the LED, see section *Positions of the LEDs* on page 26):





LED	Color	State	Meaning
SWD Status SmartWire-DT Number 4 in <i>Figure 3</i> on page 26	Duo-LED red/green/orange (orange = red/green at same time)		
	 (green)	On	The current actual configuration complies with the gateway target configuration. Data exchange between gateway and SmartWire-DT slaves takes place.
	 (red)	Flashing red	A necessary SmartWire-DT slave is missing or the gateway target configuration does not comply with the actual configuration. No data exchange between gateway and SmartWire-DT slaves.
	 (green)	Flashing green	Slave addressing is active (after power-on or the download of a planned configuration with empty modules). No data exchange between gateway and SmartWire-DT slaves.
	 (red)	On	Short-circuit on the 15 V power supply or no SmartWire-DT slave is connected. No data exchange between gateway and SmartWire-DT slaves.
 (orange)	Flashing	After having pressed the configuration button: The gateway reads the current actual configuration and stores it as target configuration.	

Table 13: SWD LED

7.2 Configuring Gateway in PROFINET IO Network

7.2.1 GSDML Device Description File

In the PROFINET engineering tool of the PLC programming system, the EU5C-SWD-PROFINET Gateway is integrated as PROFINET IO Device – i. e. as slave device. For this, a device description file (GSDML file) containing a standardized description of the gateway is necessary.

The ongoing development of the SmartWire-DT communication system results in different versions of the GSDML files. The relation between supported SmartWire-DT devices, gateway firmware versions and GSDML versions is shown in section *Compatibility of SmartWire-DT Devices and Gateway* on page 98.

You will find the GSDML file on the product DVD in the EDS\EU5C-SWD-PROFINET directory. You can also download the latest version of a GSDML file from our website www.hilscher.com under **Support > Downloads**.

Copy the relevant GSDML files together with the relevant bitmap files to the relevant directory of your PROFINET engineering tool or use the import function of the tool. For further information on this, please refer to the documentation of your engineering tool.

7.2.2 Creating Communication With PROFINET IO

If a data interchange is possible between the SmartWire-DT slaves and the gateway, in principle also communication between the gateway and the controller can be established via PROFINET IO.

- Connect the gateway to the PROFINET IO bus.
- Load the PROFINET IO configuration and possibly a controller program to the PLC.

On uploading the PROFINET IO configuration/program from the engineering tool to the PLC, the configuration of the entire PROFINET IO network is transferred to the PROFINET IO Controller (master). The PROFINET IO Controller then transfers the planned SmartWire-DT configuration, which is included in the PROFINET IO configuration, to the gateway, where it is being tested.

If the planned configuration complies with the stored gateway configuration, all status LEDs indicate a green continuous light. Any errors that occur are indicated via the Application status LED and the Config status LED.







LED	Color	State	Meaning
APL Application status Number ② in <i>Figure 3</i> on page 26	Duo-LED red/green		
	 (green)	On	The communication on PROFINET and SmartWire-DT is in cyclic data exchange and the gateway function is executed.
	 (green)	Flashing 2 s off, 0.5 s on	Gateway is initialized, but the communication on PROFINET is not in cyclic data exchange.
	 (green)	Flashing 2 s off, 0.5 s on, 0.5 s off, 0.5 s on	Gateway is initialized, but the communication on SmartWire-DT is not in cyclic data exchange.
	 (red)	Flashing 2 s off, 0.5 s on	Gateway is initialized, but the configuration for the communication protocol on PROFINET is missing or in error.
	 (red)	Flashing 2 s off, 0.5 s on, 0.5 s off, 0.5 s on	Gateway is initialized, but the configuration for the communication protocol on SmartWire-DT is missing or in error.
 (red)	On	Gateway has detected an error during the initialization: Missing configuration, error in configuration or internal error.	

Table 14: APL LED

Prerequisite for data interchange is that the PROFINET configuration drawn up in the PROFINET engineering tool (= planned configuration) complies with the target configuration actually available on the gateway. The result of this check is signaled on the gateway by the SmartWire-DT configuration LED:





LED	Color	State	Meaning
Config. Configuration status Number ③ in <i>Figure 3</i> on page 26	Duo-LED red/green		
	 (green)	On	The planned configuration complies with the gateway target configuration. Data exchange between Gateway and PLC via PROFINET takes place.
	 (green)	Flashing	The planned configuration does not comply with the gateway target configuration, but is compatible with it. Data exchange between gateway and PLC via PROFINET takes place.
	 (red)	On	The planned configuration and the gateway target configuration are not compatible. No data exchange between gateway and PLC via PROFINET.
 (off)	Off	No communication with the PROFINET IO controller or the gateway does not contain a project configuration.	

Table 15: Config LED

7.3 Example: Using STEP 7 to Create a Gateway Project in PROFINET IO Network Controlled By S7-300 PLC

7.3.1 Overview

The following example shows how to use the STEP 7 programming software to configure and program the EU5C-SWD-PROFINET Gateway in a PROFINET IO network which is controlled by a S7-300 PLC.

For this example, you need the following hard- and software:

- PROFINET engineering tool:
Programming device or PC with installed STEP 7 software (= programming system)
- GSDML device description file for EU5C-SWD-PROFINET Gateway
- S7-300 PLC
- EU5C-SWD-PROFINET Gateway
- PROFINET IO network
- SmartWire-DT network with slaves

To create and implement the gateway project, the following steps have to be performed in STEP 7:

1. Create new project
2. Import GSDML file
3. Configure PROFINET IO Controller (S7-300 PLC)
4. Configure PROFINET IO network
5. Configure gateway in PROFINET IO
6. Configure SmartWire-DT slaves in PROFINET IO
7. Save and compile configuration
8. Load configuration to S7-300 PLC (PROFINET IO Controller)
9. Program controller
10. Load controller program to S7-300 PLC (PROFINET IO Controller)

7.3.2 Step-by-Step Instructions for Configuring Gateway with STEP 7

7.3.2.1 Create Project in STEP 7

1. Start STEP 7 SIMATIC Manager.
 - In the Windows **Start** menu, choose **All Programs > SIMATIC > SIMATIC Manager**.
 - The SIMATIC Manager opens.
 - If the **STEP 7 Wizard: “New Project”** appears, close the wizard by clicking the **Cancel** button.
2. Create new project.
 - In the menu, choose **File > New**.
 - The **New Project** dialog box opens.

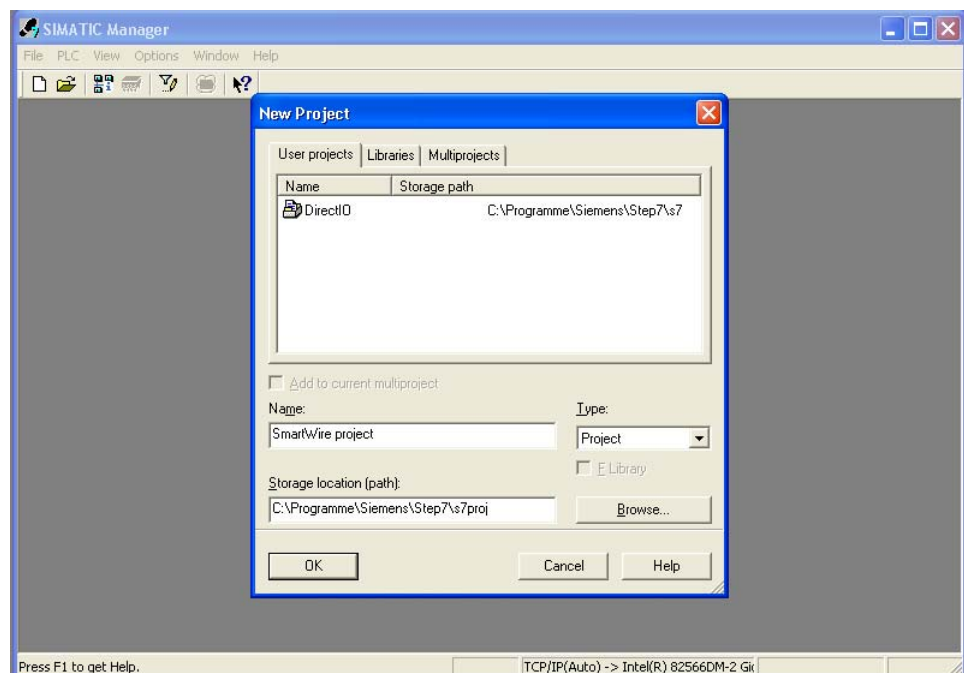

Figure 13: Create New Project in SIMATIC Manager

- In the **User projects** tab, use the **Name** field to enter the name of your project. In the **Type** drop-down list, select **Project** entry.
 - Click **OK** button.
 - The **New Project** dialog box closes, and a window containing the new project opens.
3. Add PLC to the project.
 - In the project tree of the project window (in the left part of the project window), select your new project.
 - In the menu bar, choose **Insert > Station > SIMATIC 300 Station**.

➤ The PLC is displayed in the project window.

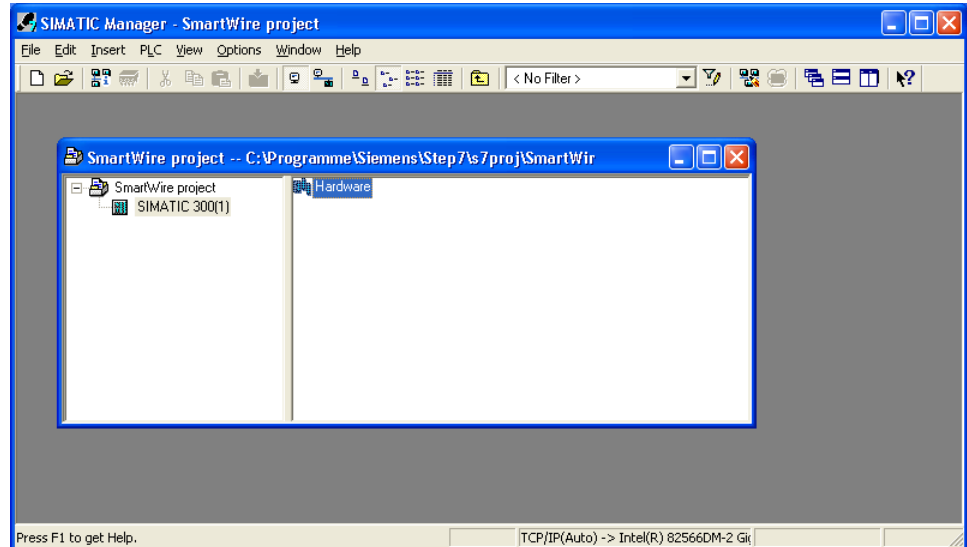

Figure 14: PLC Added to the Project

4. Open Hardware Configuration.

- In the project tree, select **SIMATIC 300(1)** symbol, then double-click **Hardware** symbol in the right part of the project window.
- The **HW Config** (Hardware Configuration) window for the project opens.

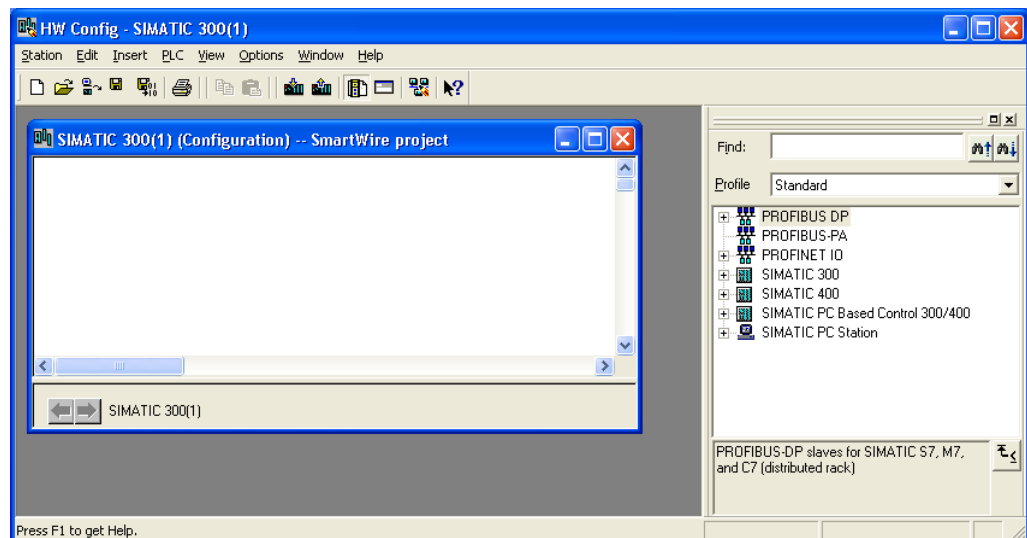

Figure 15: Hardware Configuration Window

7.3.2.2 Import GSDML Device Description File

- In the menu bar of the **HW Config** window, choose **Options > Install GSD File...**
- The **Install GSD Files** dialog box opens:

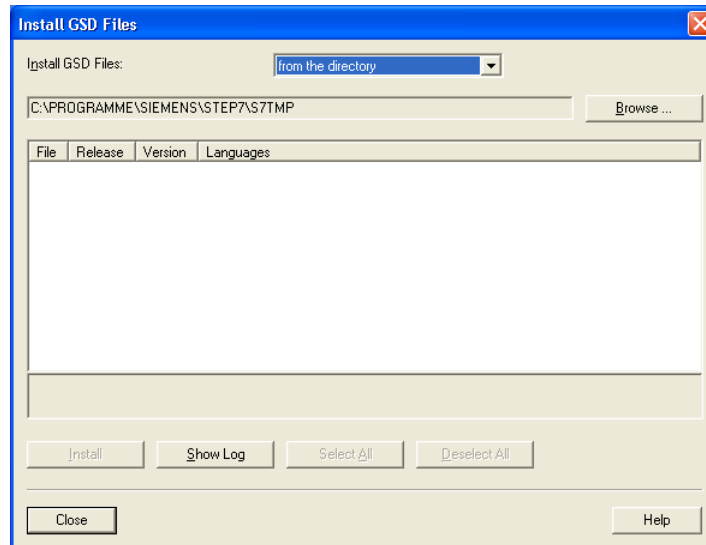

Figure 16: Install GSD Files Dialog Box

- Choose the directory where the GSDML file you want to install is stored. In the drop-down list located next to the **Install GSD Files** entry, select **from the directory** entry, then click **Browse...** button.
- The Windows **Search Folder** dialog opens.
- Navigate to the relevant directory, select relevant folder and click **OK** button.
- The **Search Folder** dialog closes, and in the **Install GSD Files** dialog box all GSD and GSDML files stored in that folder are displayed:

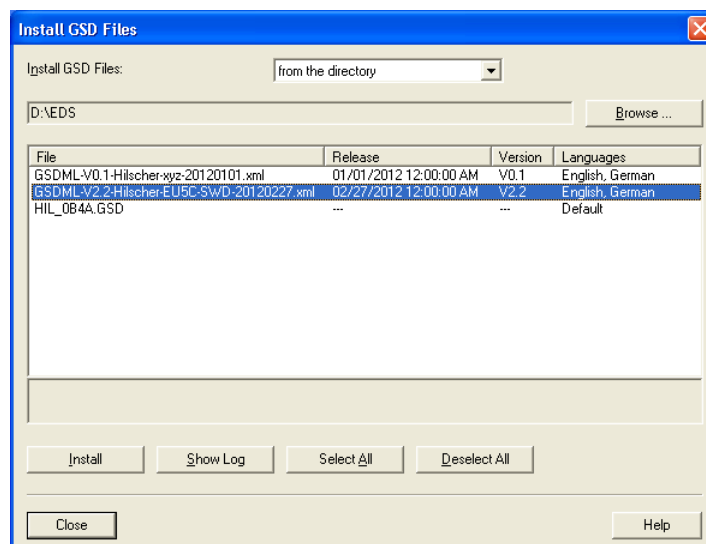

Figure 17: Select GSDML File



Note: Usually the GSDML file is delivered together with a bitmap file containing an icon, which symbolizes the gateway in the GUI of the programming system. This bitmap file must be stored in the same folder as the GSDML file, so that it can automatically be installed together with the GSDML file. Please note, that this bitmap file is not displayed in the **Install GSD Files** dialog box, even if it's actually there. Therefore, if you are in doubt, use the Windows Explorer to check whether the bitmap file is really present in the chosen folder.

- Select the relevant GSDML file, then click **Install** button.
- The GSDML file is installed. If an older version of the GSDML file has been installed before, this older file is transferred to a backup directory.
- Acknowledge all messages by clicking **Yes** or **OK**.
Click **Close** button to quit the **Install GSD Files** dialog box.
- In the **Hardware Catalog** of the **HW Config** window, the EU5C-SWD-PROFINET Gateway is displayed under **PROFINET IO > Additional Field Devices > Gateway**.



Note: If the **Hardware Catalog** is not visible by default, you can open it in the menu bar of the **HW Config** window by choosing **View > Catalog**.

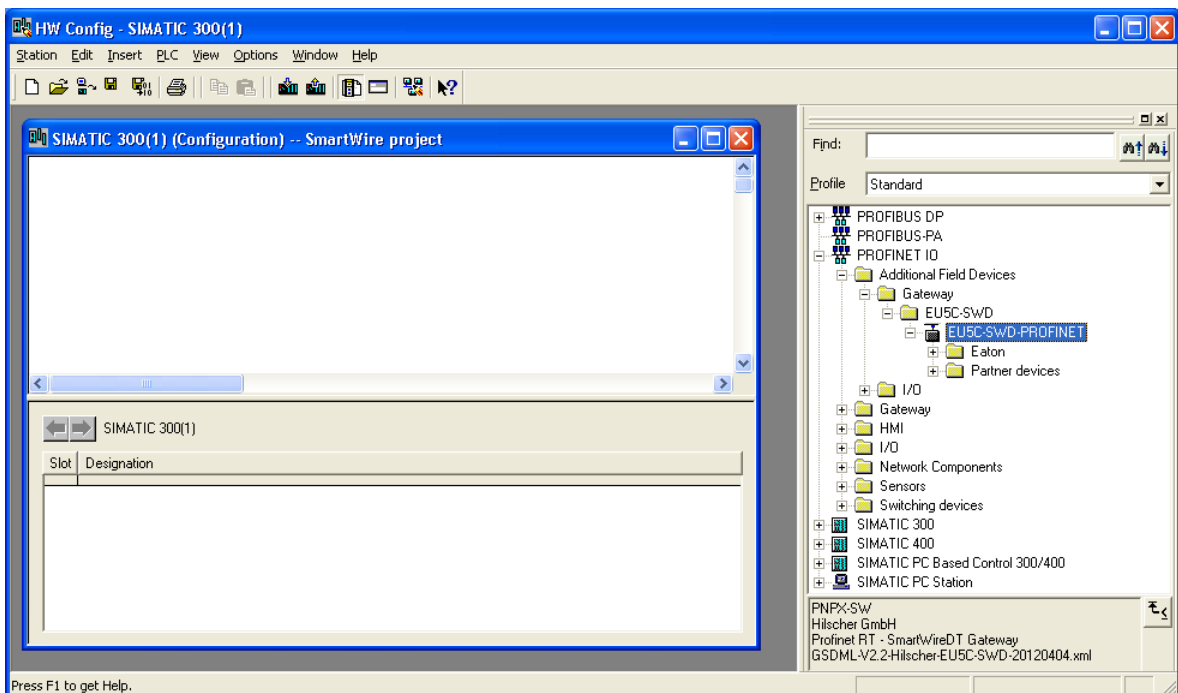

Figure 18: Installed GSDML File

7.3.2.3 Configure PROFINET IO Controller

1. Add rail (carrier rack) for IO Controller (PLC).
 - In the **Hardware Catalog** of the **HW Config** window, under **SIMATIC 300 > RACK-300**, choose **Rail** object, and drag and drop it into the configuration window.

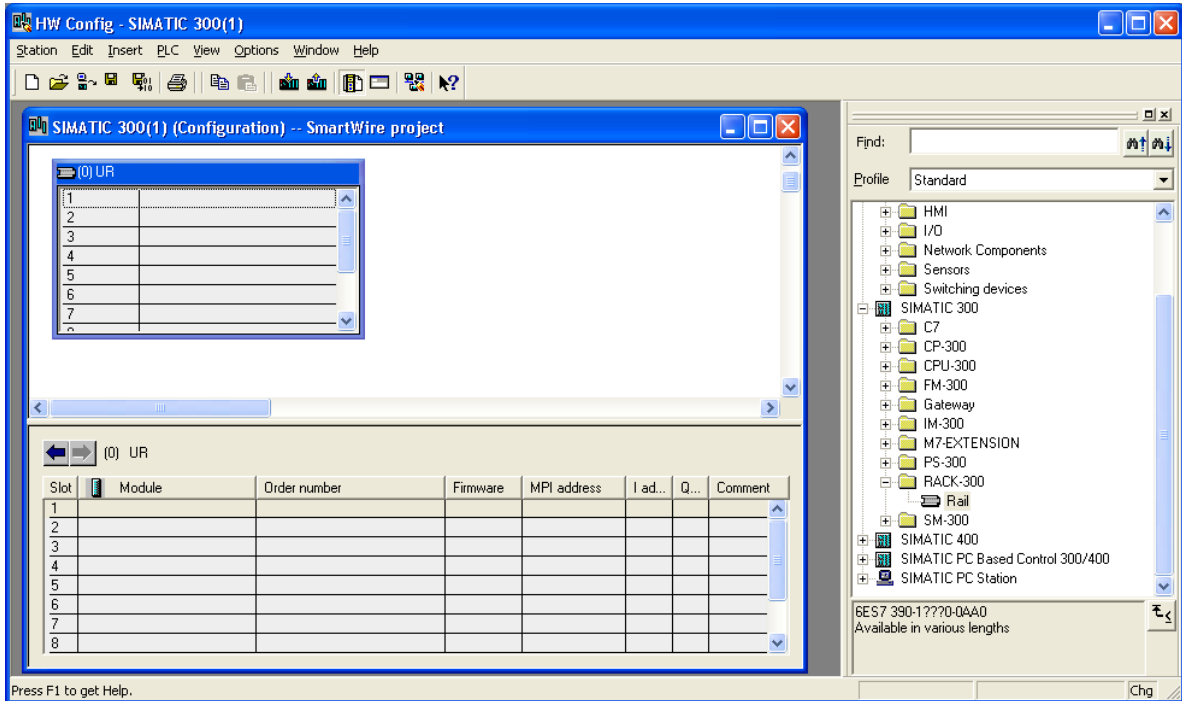

Figure 19: Added Rail

- The rail is displayed in the configuration window.
2. Add power supply module for IO Controller (PLC).
 - In the **Hardware Catalog** of the **HW Config** window, under **SIMATIC 300 > PS-300**, choose the appropriate power module, e. g. **PS 307 10A**, and drag and drop it onto **Slot 1** of the rail in the configuration window.



Note: Once you have selected an object in the hardware catalog, all slots in the configuration window onto which the object can be dropped, are highlighted in a green color. This helps you to find the right slot.

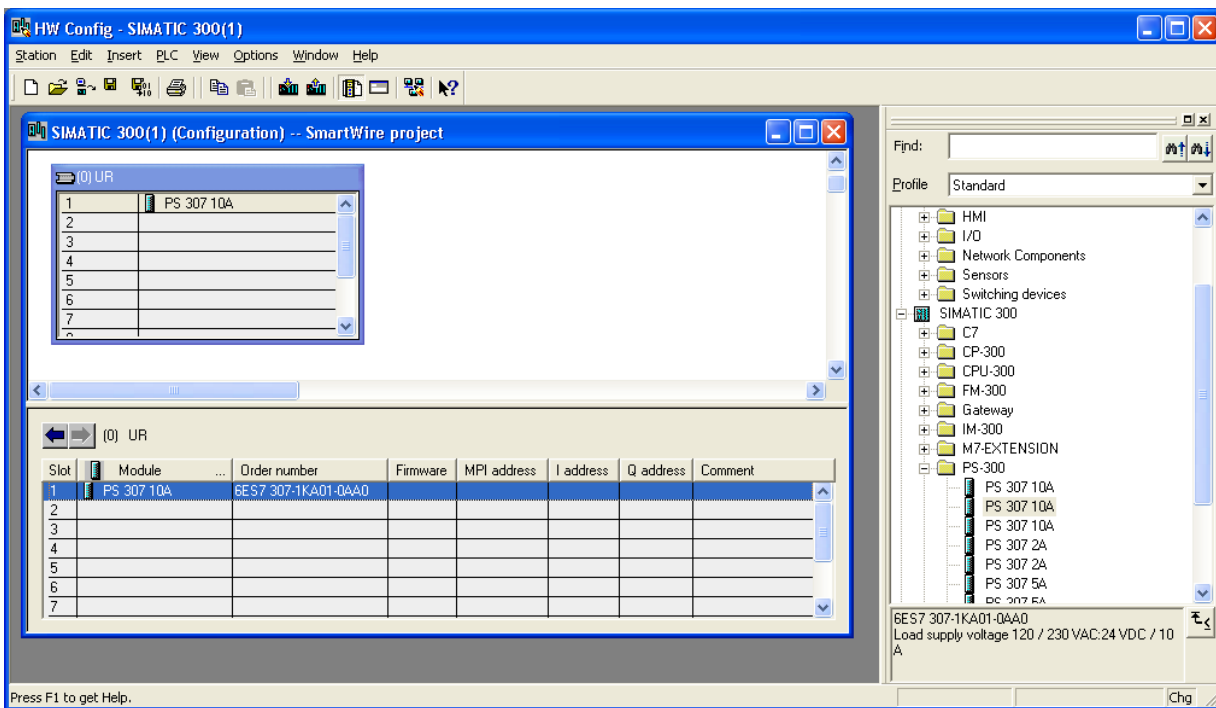

Figure 20: Added Power Module

- In the configuration window, the added power module is displayed in the rail.
3. Add CPU for IO Controller (PLC).
- In the **Hardware Catalog** of the **HW Config** window, choose the CPU you are using, e. g. **SIMATIC 300 > CPU-300 > CPU 315-2 PN/DP > 6ES7 315-2EH13-0AB0 > V2.6**, and drag and drop it onto **Slot 2** of the rail in the configuration window.

- On dropping the CPU onto the slot, the **Properties – Ethernet Interface** sheet automatically opens:

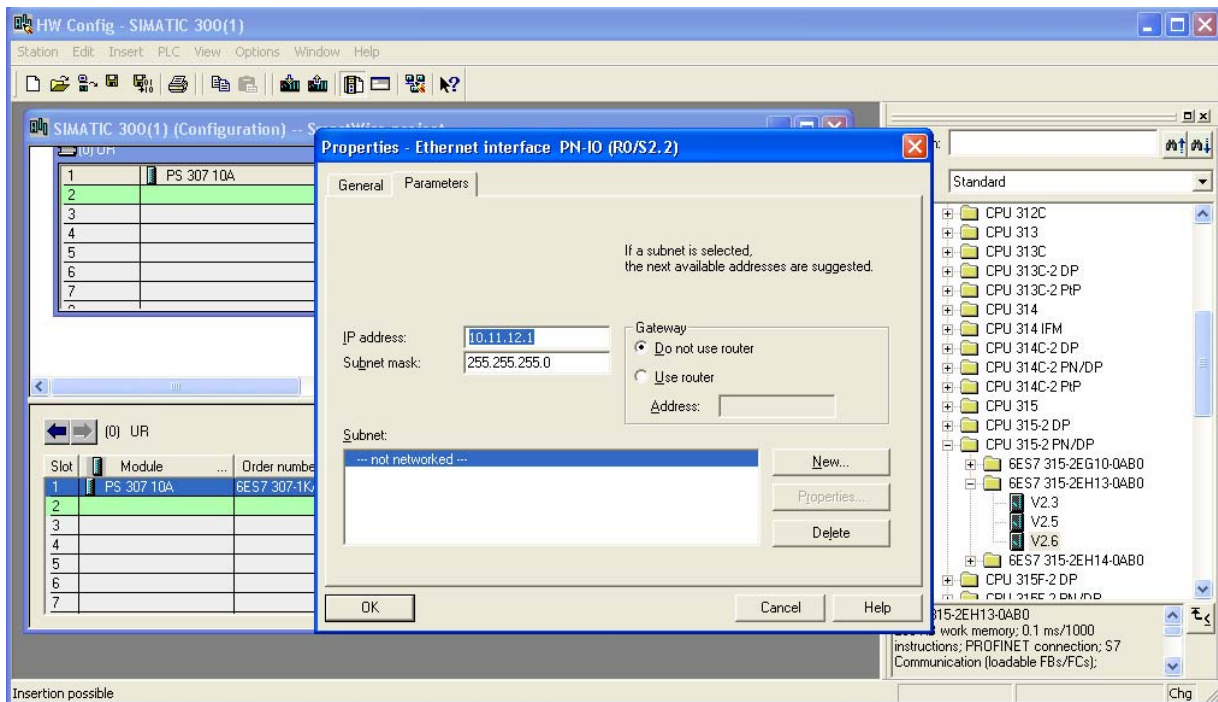

Figure 21: Add CPU

- In the **Parameters** tab of the **Properties – Ethernet Interface** sheet, enter **IP address** and **Subnet mask** or accept the preset default values. You can also set the IP address later during the next step, when you add a PROFINET IO network to the project.



Note: Consult your network administrator about IP addresses, if you intend to use your company's Ethernet network.

- Click **OK** button, to close the **Properties – Ethernet Interface** sheet.

- After the **Properties – Ethernet Interface** sheet is closed, the added CPU with its interfaces is displayed in the rail in the configuration window:

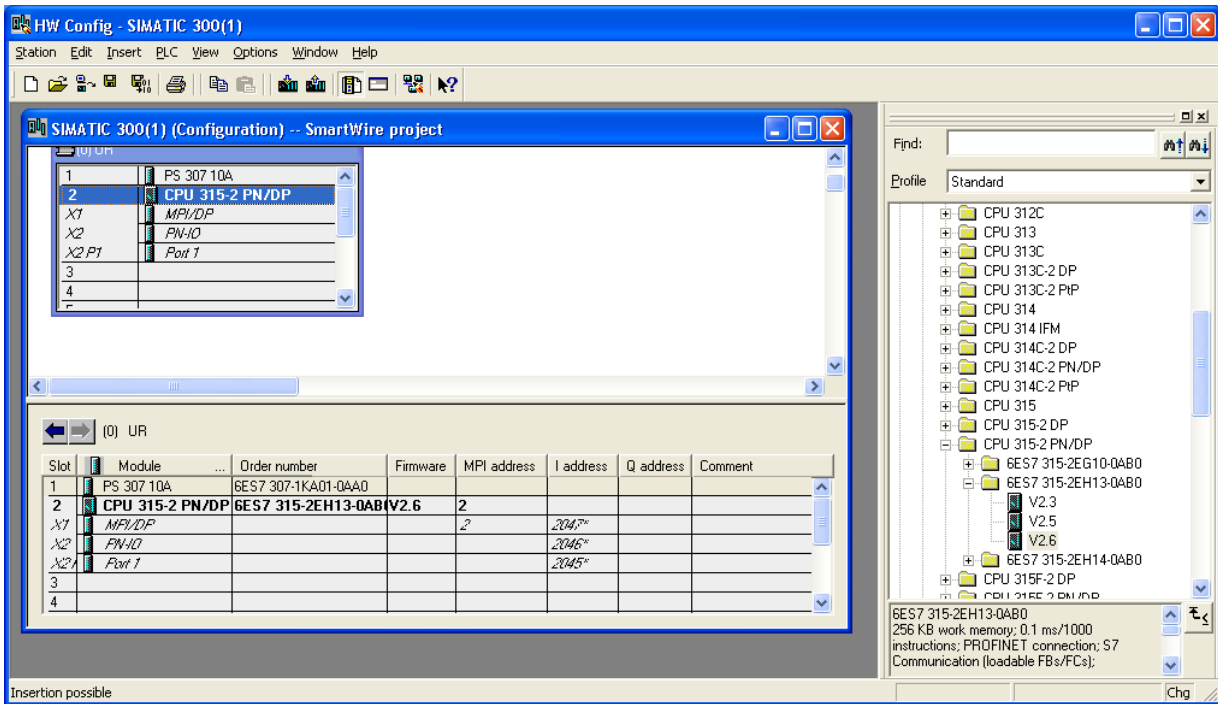

Figure 22: Added CPU

7.3.2.4 Configure PROFINET IO Network

1. Add PROFINET IO network.

- In the configuration window, right-click the **X2 PN-IO** interface, then choose **Insert PROFINET IO System** from the context menu.
- The **Properties – Ethernet Interface** sheet, which you have already seen in the previous step when you added the CPU, opens again. The **IP address** and the **Subnet mask** are displayed in the **Parameters** tab and can be changed here once again.

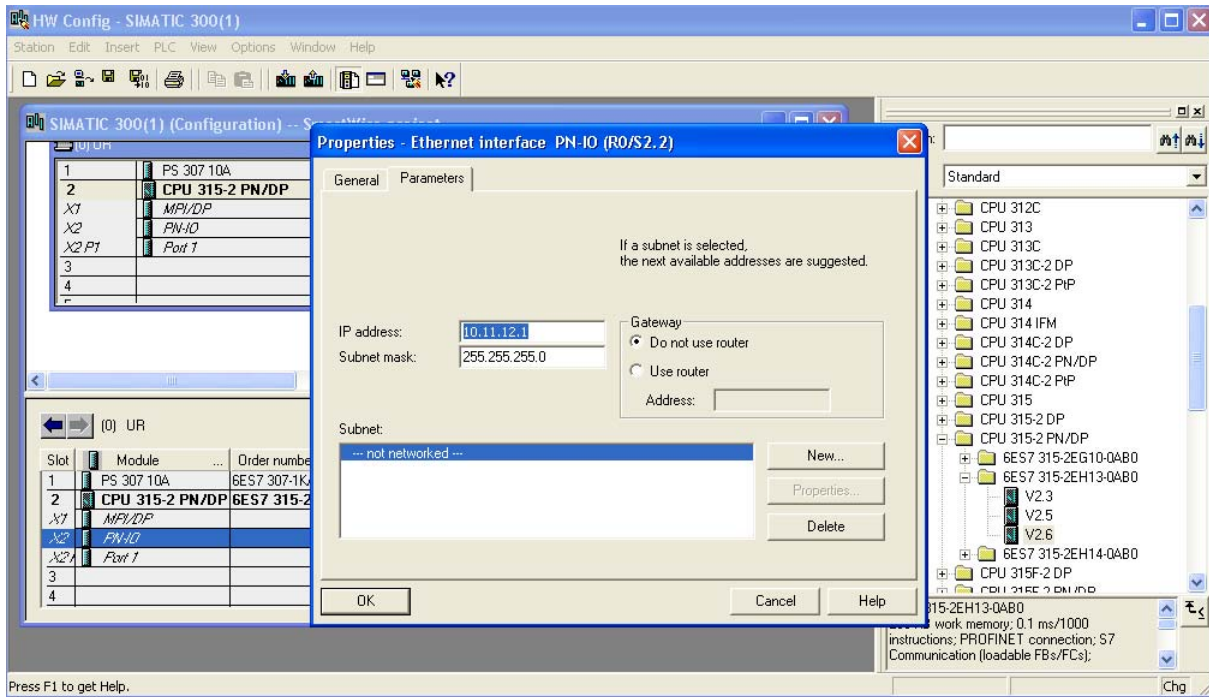

Figure 23: Add PROFINET IO (1)

2. Set parameters for PROFINET IO network.

- If necessary, change the values of the **IP address** and the **Subnet mask** in the **Parameters** tab.
- In the **Parameters** tab, click **New...** button.

➤ The **Properties – New subnet Industrial Ethernet** sheet opens:

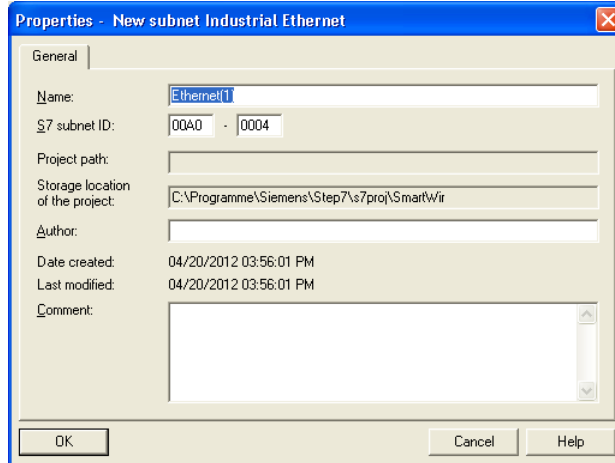

Figure 24: Add PROFINET IO (2)

- In the **Name** field of the **Properties – New subnet Industrial Ethernet** sheet, enter a new name for the network, or accept the preset default name. Then click **OK** button.
- You are back in the **Properties – Ethernet Interface** sheet.
- In the **Properties – Ethernet Interface** sheet, click **OK** button.
- The **Properties – Ethernet Interface** sheet is closed, and in the configuration window, the newly added PROFINET IO network is depicted as PROFINET bus line.

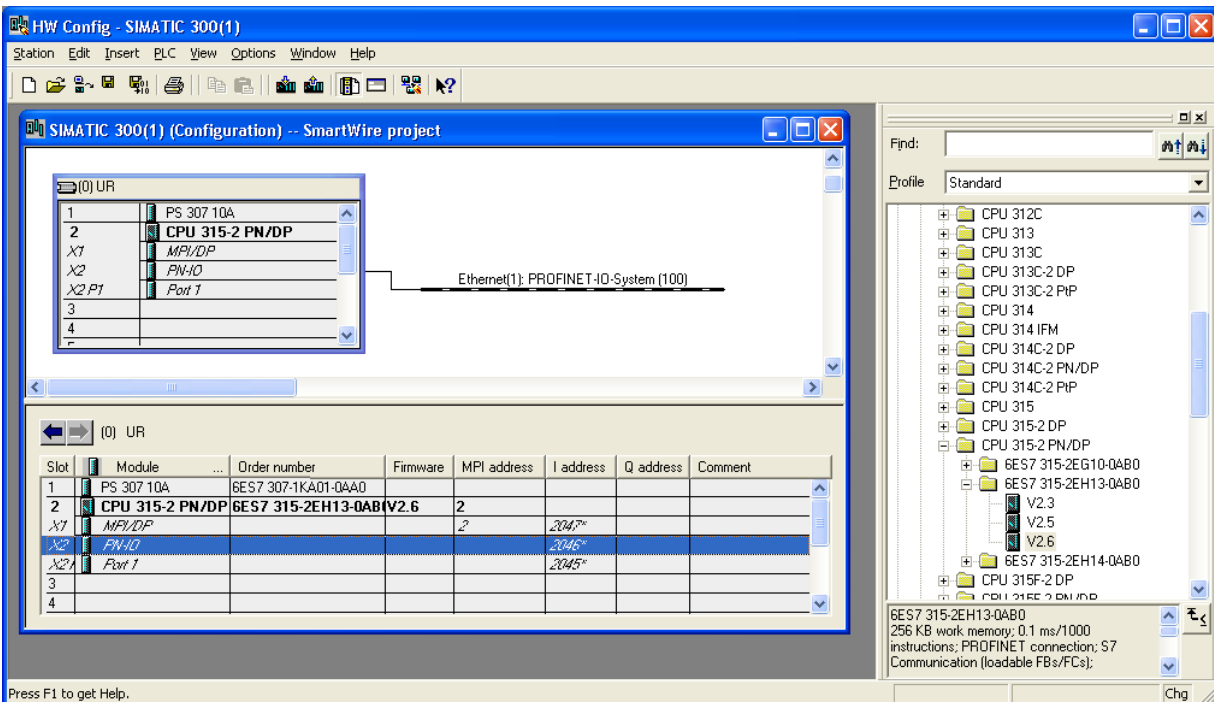

Figure 25: Added PROFINET IO Network

7.3.2.5 Configure Gateway in PROFINET IO

1. Add Gateway.

- In the **Hardware Catalog**, under **PROFINET IO > Additional Field Devices > Gateway > EU5C-SWD**, select the **EU5C-SWD-PROFINET** object and drag it into the configuration window, then drop it below the PROFINET bus line, which you have added in the previous step.
- In the configuration window, the PROFINET bus line is depicted with the connected gateway:

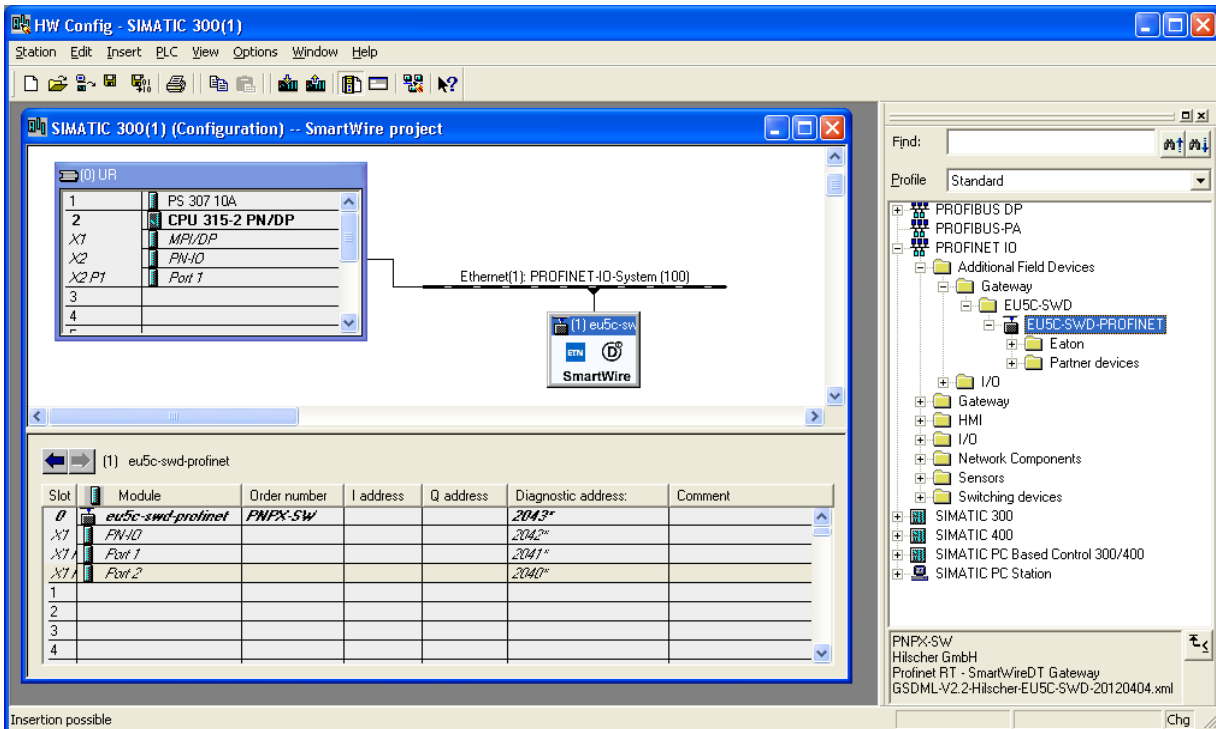

Figure 26: Added Gateway

2. Set device name of gateway in PROFINET IO network.

- In the upper part of the configuration window, double-click the gateway symbol.

➤ The **Properties** sheet of the gateway opens:

Figure 27: Set Device Name of Gateway

- In the **Device name** field of the **General** tab, you see the preset name of the gateway, which the STEP 7 software has taken over from the imported GSDML file. The PROFINET IO controller (the PLC) uses this name to address the gateway in the network.
- Keep the preset name, if you intend to use only one EU5C-SWD-PROFINET Gateway in your PROFINET network. If you intend to use more than one gateway, you must define a unique new name for each additional gateway. In that case you can keep the preset name for your first gateway, but have to enter a new **Device name** in the corresponding **Properties** sheets of the other gateways.



Important: Please note that you need to define these new names not only within the STEP 7 configuration, but that you also need to transfer the new names onto the additional gateways and save them there, in order to overwrite the preset standard name stored in each gateway. Otherwise the additional gateways will not respond when contacted by the PROFINET IO controller.

For information on how to change the device name on a gateway, see section *Using STEP 7 to Assign Device Name or IP Address on the Gateway* on page 81.

- Click **OK** button to close the **Properties** sheet.



Note: If you have installed more than one version of a GSDML device description file in the course of time, you can use the **Change Release Number...** button in the **General** tab of the **Properties** sheet to open a dialog box, in which you can choose an older version of the GSDML file to be used to configure the gateway.

Older versions of GSDML files are moved to a backup directory when new GSDML files are being imported to STEP 7, see *Import GSDML Device Description File* section on page 48.

3. Define IP address for gateway in PROFINET IO.

- In the upper part of the configuration window, right-click the gateway symbol, then choose **Edit PROFINET IO System IP address** from the context menu.

➤ The **Edit IP Addresses** dialog box opens:

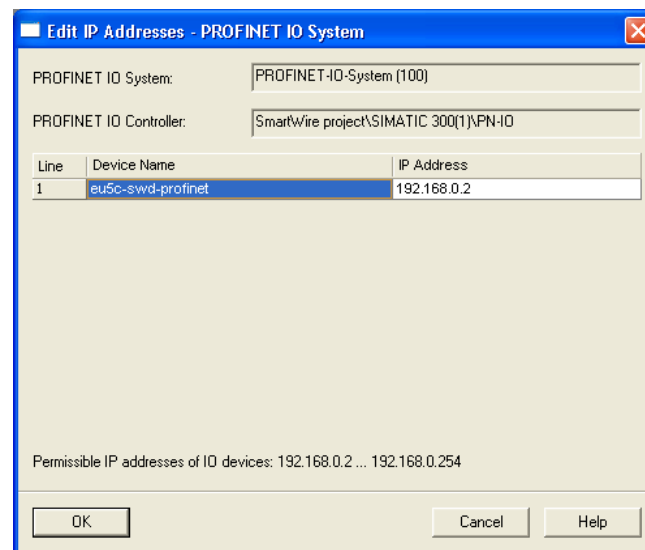

Figure 28: Set IP Address of Gateway

- Accept the IP address determined by the PROFINET IO controller, or click the **IP Address** field and enter a new address.
- Click **OK** button to close **Edit IP Addresses** dialog box.

4. Set further parameters of gateway.

- In the upper part of the configuration window, select the gateway symbol **①**, then double-click the gateway entry on **Slot 0** **②** in the lower part of the configuration window.

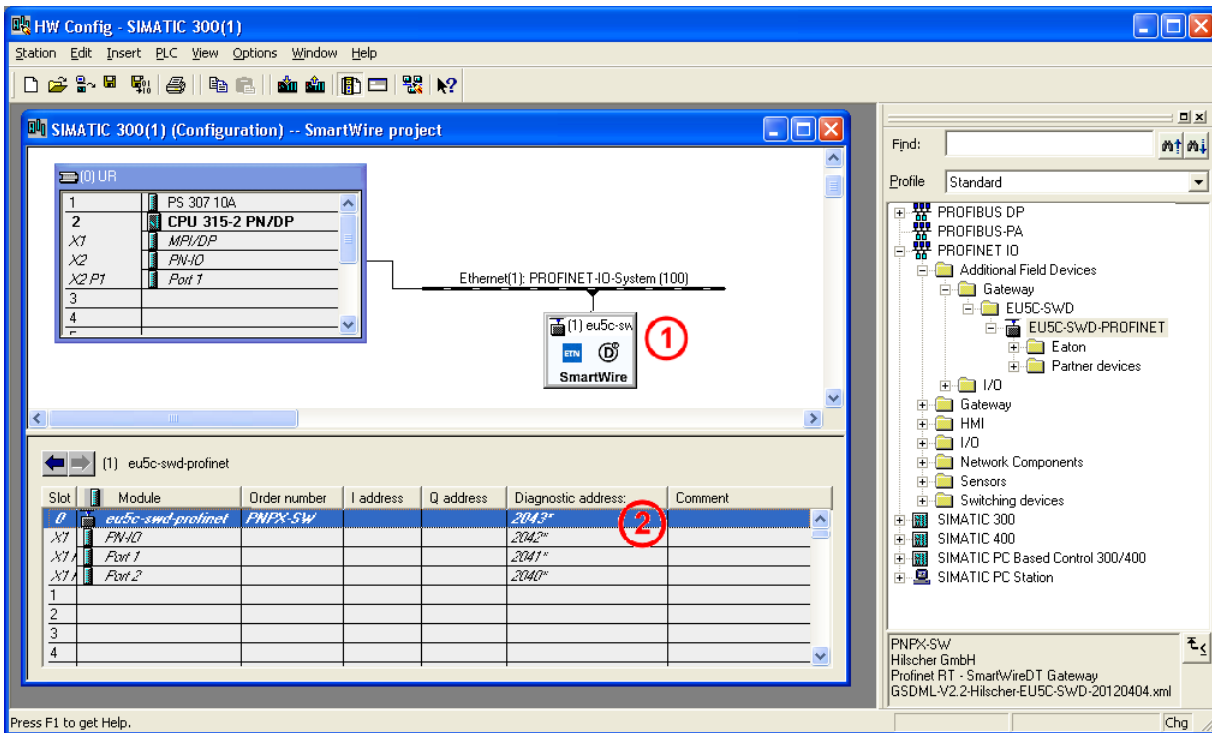

Figure 29: Set Further Gateway Parameters (1)

➤ The **Properties** sheet opens.



Note: The Gateways has two different **Property** sheets in STEP 7. One opens, if you double-click on the gateway symbol **①** in the upper part of the configuration window, the other opens, if you double-click the gateway entry on **Slot 0** **②** in the lower part of the configuration window.

In the **General** tab, you can enter a comment:

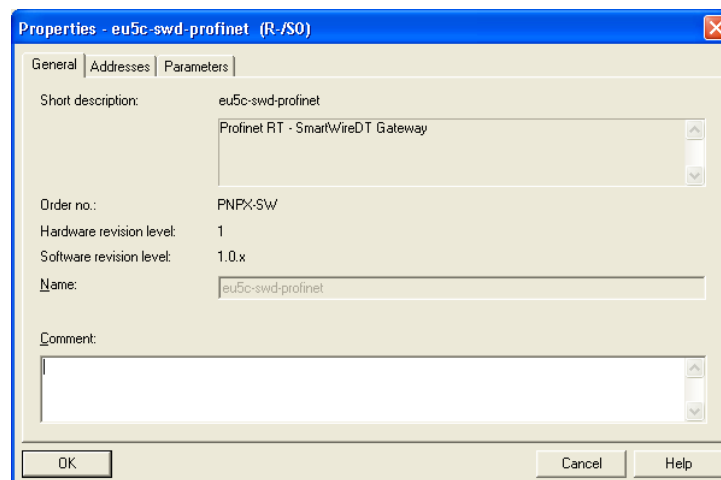

Figure 30: Set Further Gateway Parameters (2)

- Click the **Comment** field and enter your text.

- After closing the **Properties** sheet, the text will be displayed in the **Comment** column in the lower part of the configuration window.

In the **Addresses** tab, you can accept or change the preset diagnostic address of the gateway:

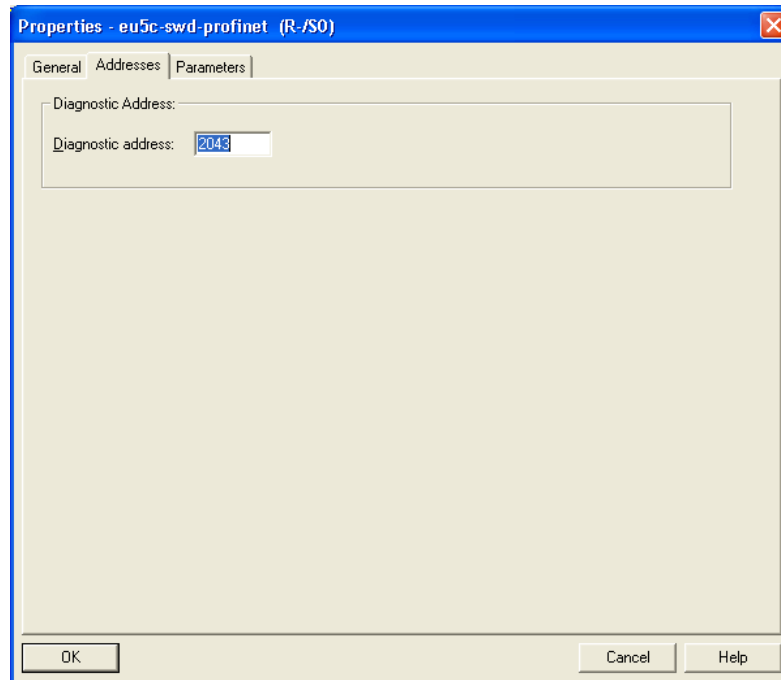

Figure 31: Set Diagnostic Address of Gateway

- Click the **Diagnostic address** field and enter the new address.

In the **Parameters** tab, you can set the application parameters of the gateway in regard to its function as master in the SmartWire-DT network.

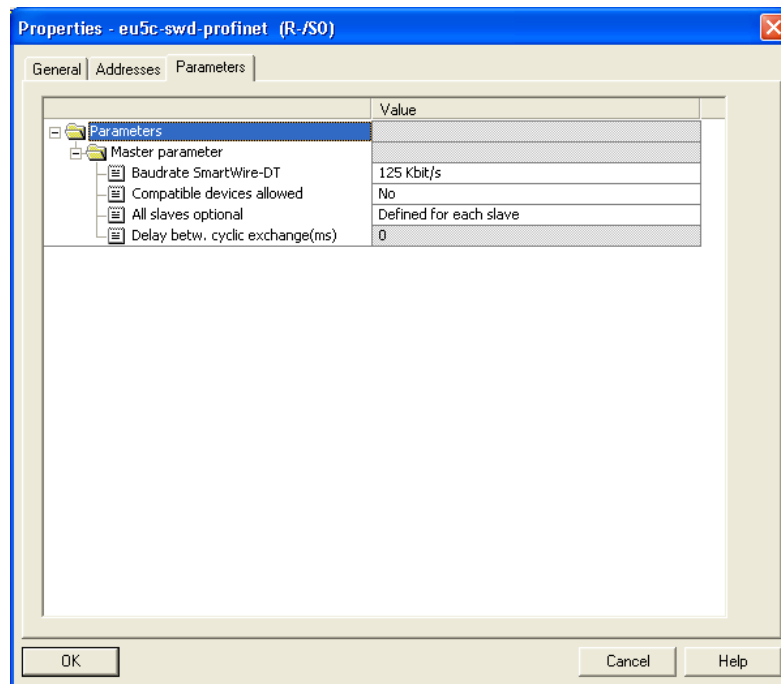

Figure 32: Set Application Parameters of Gateway

- In the **Value** column, click the entry you want to change. As soon as you click a value, a drop-down list opens, in which you can select other values.

You can set the following parameters:

Parameter	Value	Description
Baudrate SmartWire-DT	125 kBit/s	The baud rate of the SmartWire-DT network.
	250 kBit/s	
Compatible devices allowed	No	The planned SmartWire-DT slaves in the PROFINET IO configuration must comply 100 % with the SmartWire-DT slaves of the stored gateway target configuration. If not, no data interchange takes place with the PROFINET IO controller.
	Yes	Data exchange takes place, if the connected SmartWire-DT slaves are different but compatible with the planned SmartWire-DT slaves in the PROFINET IO configuration. This is indicated by the Config LED on the gateway.
All slaves optional	Defined for each slave	Specification is performed individually for each SmartWire-DT slave.
	Yes	Data transmission to the PROFINET IO also takes place for a random number of failed SmartWire-DT slaves. The setting in the module parameters of the SmartWire-DT slaves has no effect. See <i>Application Parameters of Slave</i> table on page 66.
Delay between cyclic exchange (ms)	0	Reserved option, other settings currently not supported.

Table 16: Application Parameters of Gateway

- Click **OK** button to close the **Properties** sheet.

7.3.2.6 Configure SmartWire-DT Slaves in PROFINET IO

1. Add SmartWire-DT slaves.



Note: If you are using a project-specific GSDML device description file which was created by the SWD-Assist software and which contains preconfigured SmartWire-DT slaves, you don't need to add and configure SmartWire-DT slaves as described in the subsequent section.

For information on project-specific GSDML files created with SWD-Assist, please refer to the SWD-Assist online help.

- In the configuration window, select the gateway symbol.
- In the **Hardware Catalog**, select under **PROFINET IO > Additional Field Devices > Gateway > EU5C-SWD > EU5C-SWD-PROFINET > Eaton** a slave device of your SmartWire-DT network, e. g. **EU5E-SWD-2A2A** in the **Input / Output modules** folder, then drag it into the lower part of the configuration window and drop it onto an appropriate slot of the gateway, e. g. **Slot 1**.
Slots, onto which the device can be dropped, are highlighted in green color.
- In the lower part of the configuration window, the added SmartWire-DT slave is displayed in the assigned gateway slot:

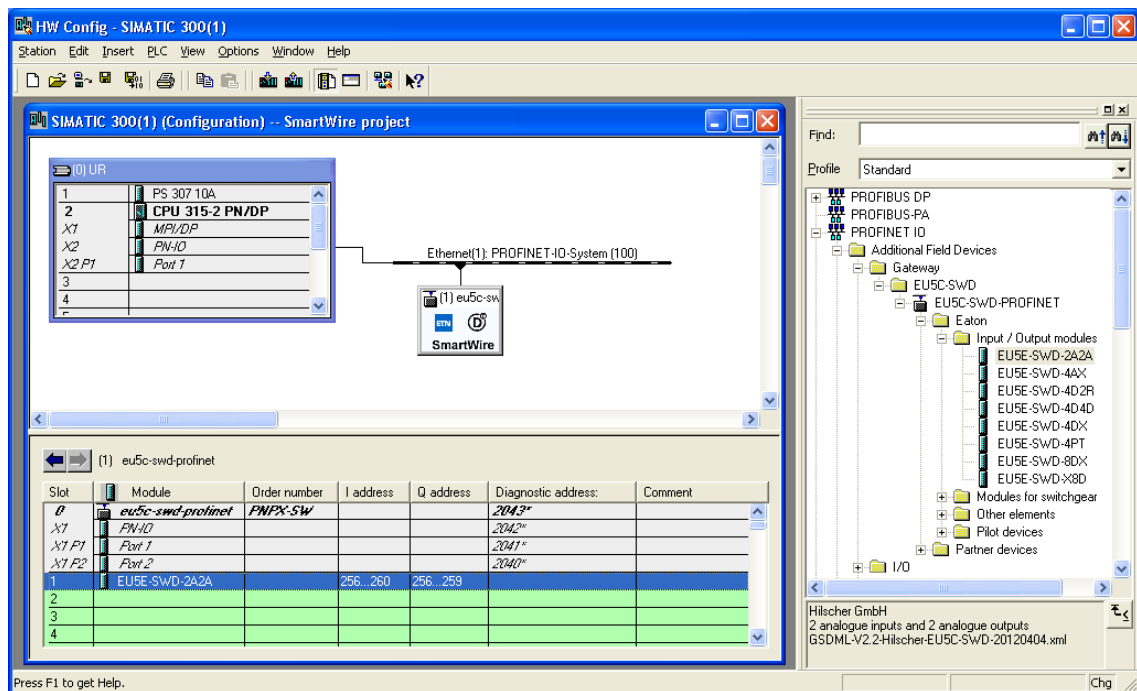

Figure 33: Added SmartWire-DT Slave

- Add other SmartWire-DT slaves as necessary. Proceed as described above.
If you are not sure about the final SmartWire-DT topology, and perhaps wish to add SmartWire-DT slaves later, you can add a placeholder. For further information, see section *Adding SmartWire-DT Slaves Later* on page 79.



Important:

- Observe the correct order of the SmartWire-DT slaves in the SmartWire-DT network. The SmartWire-DT slaves must be configured in PROFINET IO in the exact order according to their arrangement in the installation.
- The universal module is not a valid SmartWire-DT slave and must not be added to the project.

2. Configure SmartWire-DT slaves.

- In the upper part of the configuration window, select the gateway symbol **1**, then double-click the slave entry, e. g. **EU5E-SWD-2A2A** on **Slot 1** **2**, in the lower part of the configuration window.

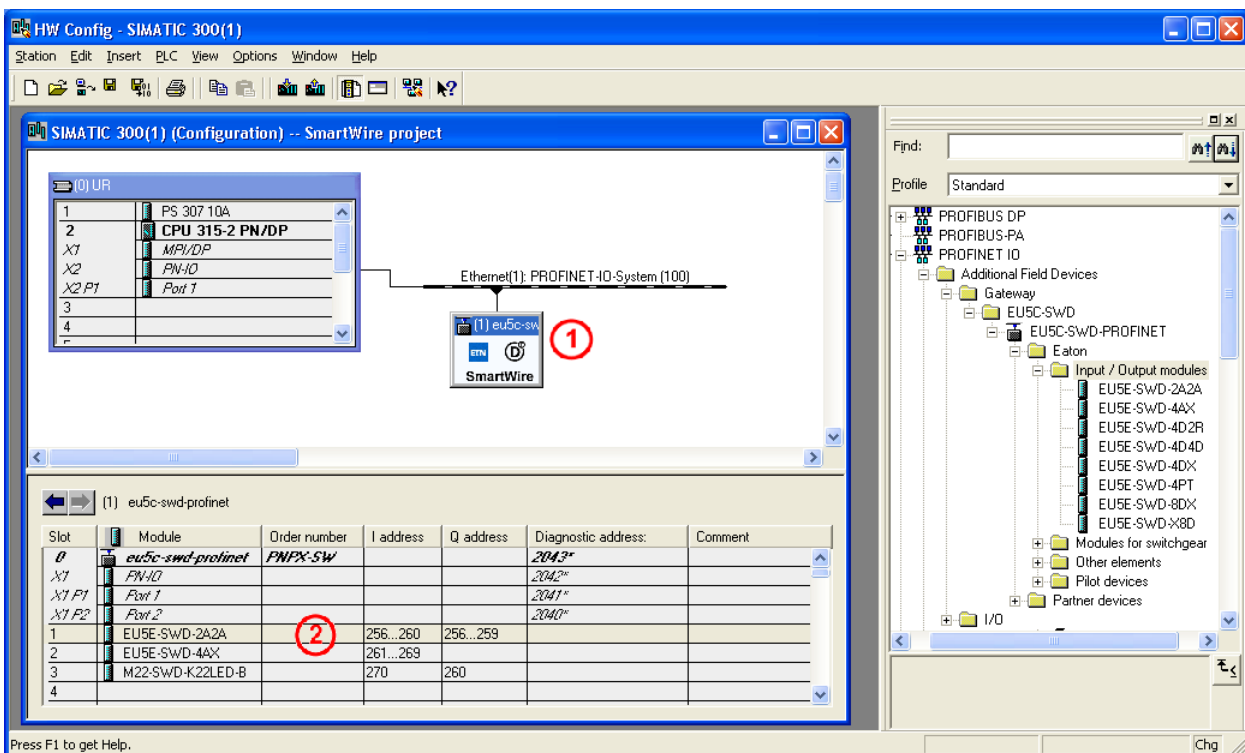

Figure 34: Configure SmartWire-DT Slave

➤ The **Properties** sheet opens.

In the **General** tab, you can accept or change the preset name of the SmartWire-DT slave.

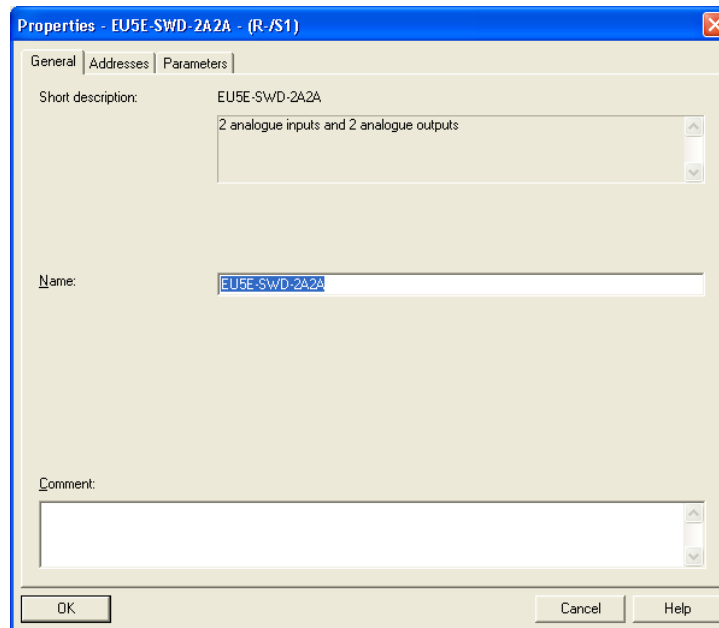

Figure 35: Set Properties of SmartWire-DT Slave

➤ Click **Name** field and enter a new name, if necessary.

In the **Addresses** tab, you can accept or change the addresses, which are reserved within the controller for the input and output data of the SmartWire-DT slave.

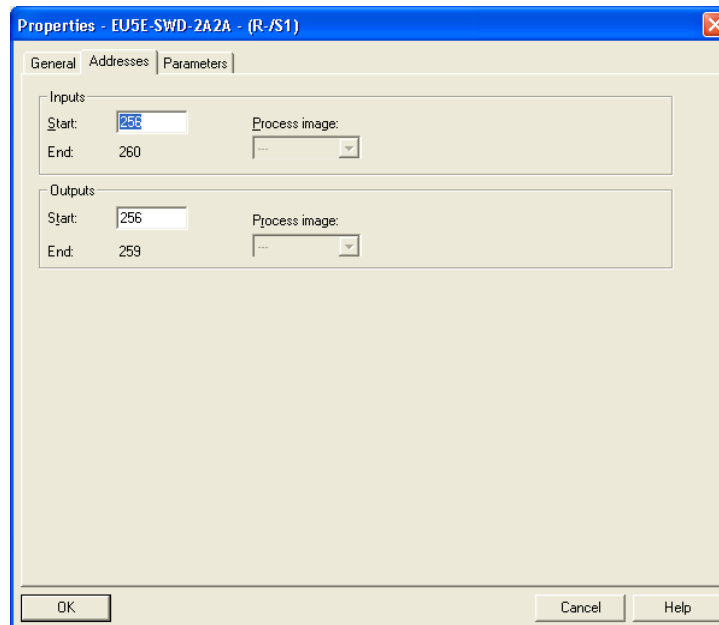

Figure 36: Set I/O Addresses of SmartWire-DT slaves, EU5E-SWD-2A2A Example



Note: On adding a SmartWire-DT slave, the addresses are assigned automatically by the system. The preset address value ensures that the start address is within the process image of the inputs and outputs.

- Click the **Start** field and enter a new start address, if necessary.

In the **Parameters** tab, you can set the application parameters of the SmartWire device in regard to its function as slave in the SmartWire-DT network. For example, you can parameterize the transient behavior for each SmartWire-DT slave. This defines how the gateway is to respond if an SmartWire-DT slave is not present. The standard setting is that all SmartWire-DT slaves have to be available.



Note: The information as to whether a SmartWire-DT slave is available, is also reported to the application via the diagnostics function, so that you can respond there to the failure of an individual slave.

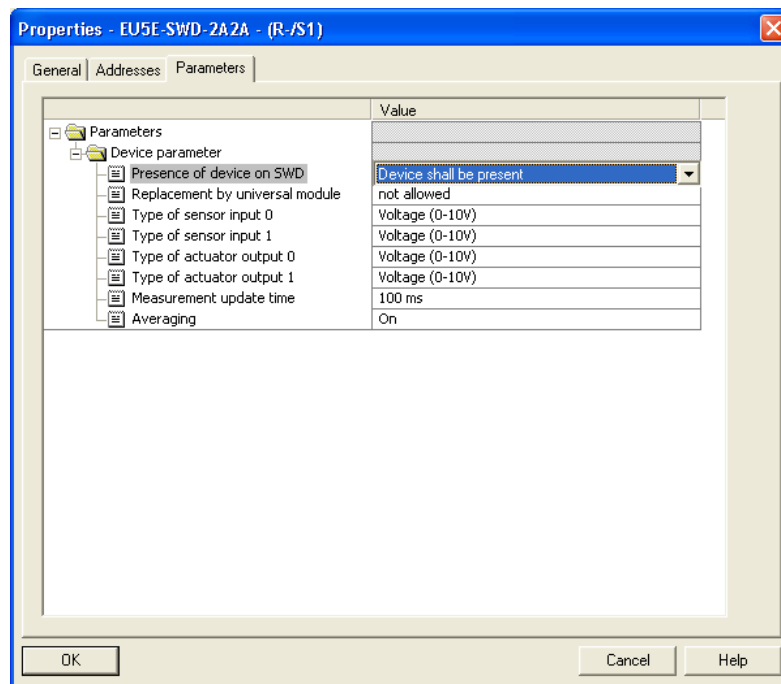

Figure 37: Set Application Parameters for SmartWire-DT Slave, EU5E-SWD-2A2A Example

- In the **Value** column, click the entry you want to change. As soon as you click a value, a drop-down list opens, in which you can select other values.

Which application parameters can be set here, depends on the individual device characteristics of the SmartWire-DT slave.



For information on individual device characteristics, please refer to the Eaton user manual *SmartWire-DT Units*, 05/11 MN05006001Z-EN.

For the EU5E-SWD-2A2A device you can set the following parameters:

Parameter	Value	Description
Presence of Device on SWD	Device shall be present	Data transfer to PROFINET takes place only if the SmartWire-DT slave is present.
	Device shall not be present	Data transfer to PROFINET takes place, even if the SmartWire-DT slave has failed or is not present.
 Note: Parameter setting at this point only makes sense, if in the application parameters of the gateway the All slaves optional parameter has been set to Defined for each slave . See <i>Application Parameters of Gateway</i> table on page 61.		
Replacement by universal module	not allowed	The SmartWire-DT slave may not be replaced by a universal module.
	allowed	The SmartWire-DT slave may be replaced by universal module M22-SWD-NOP(C).
Type of sensor input 0	Voltage (0-10V)	Defines the type of sensor/actuator the SmartWire-DT slave is using (current- or voltage-based sensor/actuator)
	Current (0-20mA)	
Type of sensor input 1	Voltage (0-10V)	
	Current (0-20mA)	
Type of actuator output 0	Voltage (0-10V)	
	Current (0-20mA)	
Type of actuator output 1	Voltage (0-10V)	
	Current (0-20mA)	
Measurement update time	20 ms; 100 ms; 200 ms; 500 ms	Defines the refresh rate of readings.
Averaging	On; Off	Switches averaging on/off

Table 17: Application Parameters of Slave

- Click **OK** button to close the **Properties** sheet.

7.3.2.7 Save and Compile Configuration

After you have finished to configure your PROFINET IO project, you must save and compile the configuration before you can upload it to your PROFINET IO controller, i. e. your S7-300 PLC.

- In the menu bar of the **HW Config** window, choose **Station > Save and Compile**.
- The hardware configuration is saved and compiled.

7.3.3 Step-by-Step Instructions for Loading PROFINET IO Configuration to S7-300 PLC

Prerequisites

- The S7-300 PLC is connected to power supply.
- The S7-300 PLC is connected to the programming device/PC with installed STEP 7 software.

Step-by-step instructions

1. Set up PG/PC interface in STEP 7.

➤ In the menu bar of the SIMATIC Manager on your programming device/PC, choose **Options > Set PG/PC Interface...**

➤ The **Set PG/PC Interface** dialog box opens:

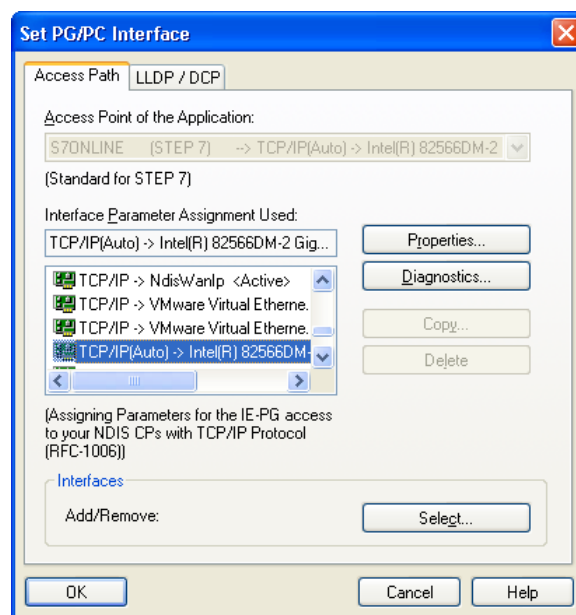

Figure 38: Set PG/PC Interface (1)

- In the **Interface Parameter Assignment Used** list of the **Access Path** tab, select the network interface card you are using on your programming device/PC.
- Click **Properties...** button.

➤ The **Properties** sheet for the selected network interface card opens:

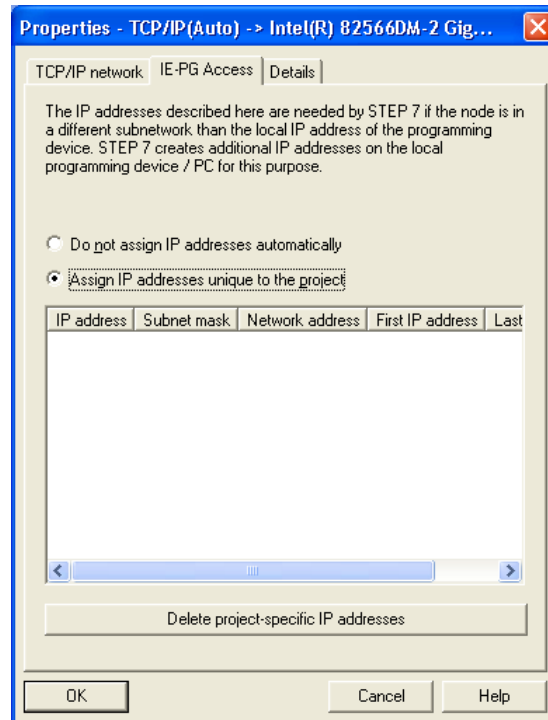

Figure 39: Set PG/PC Interface (2)

➤ In the **IE-PG Access** tab, select **Assign IP addresses unique to the project** option, then click **OK** button.

➤ You are back in the **Set PG/PC Interface** dialog box.

➤ Click **OK** button, to take over the setting of the PG/PC interface.

2. Load configuration to S7-300 PLC.

➤ Open the **HW Config** window for the Project.

➤ In the menu bar of the **HW Config** window, select **PLC > Download...**

➤ The **Select Target Module** dialog box opens:

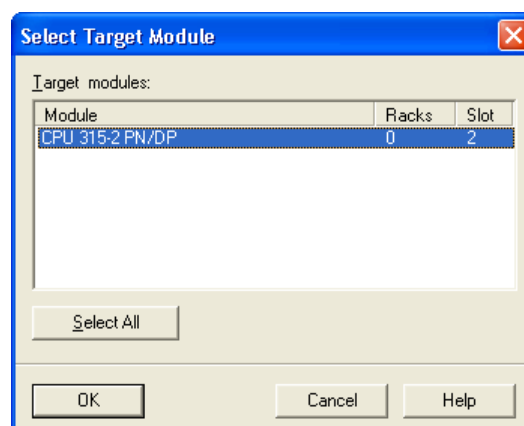

Figure 40: Select Target PLC

➤ In the **Module** list, select the target module (i. e. the CPU of the PLC), then click **OK** button.

➤ The **Select Node Address** dialog box opens:

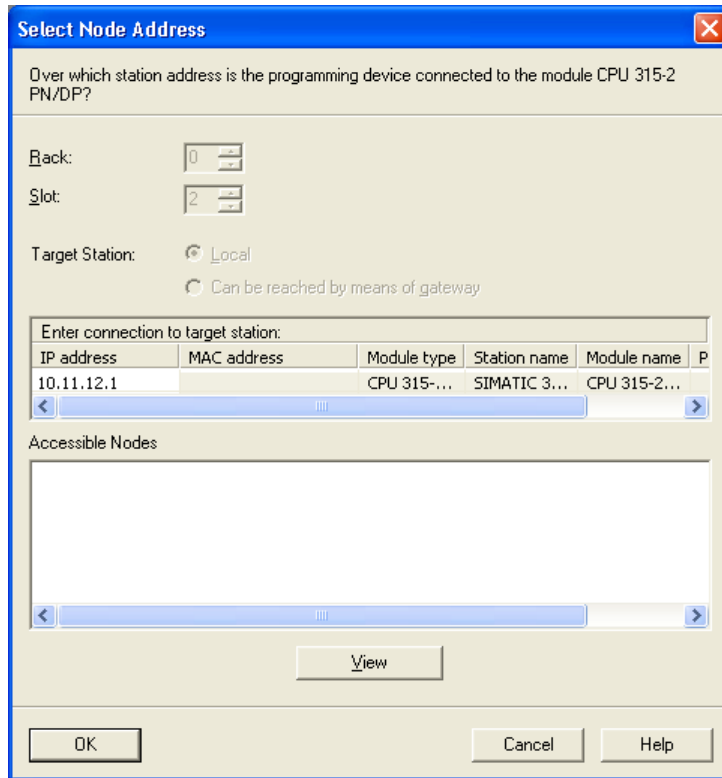

Figure 41: Select Node Address (1)

- The CPU of the PLC is not yet displayed in the **Accessible Nodes** list.
- Click **View** button.
- The programming device/PC reads the MAC addresses of the connected devices and displays them in the **Accessible Nodes** list.

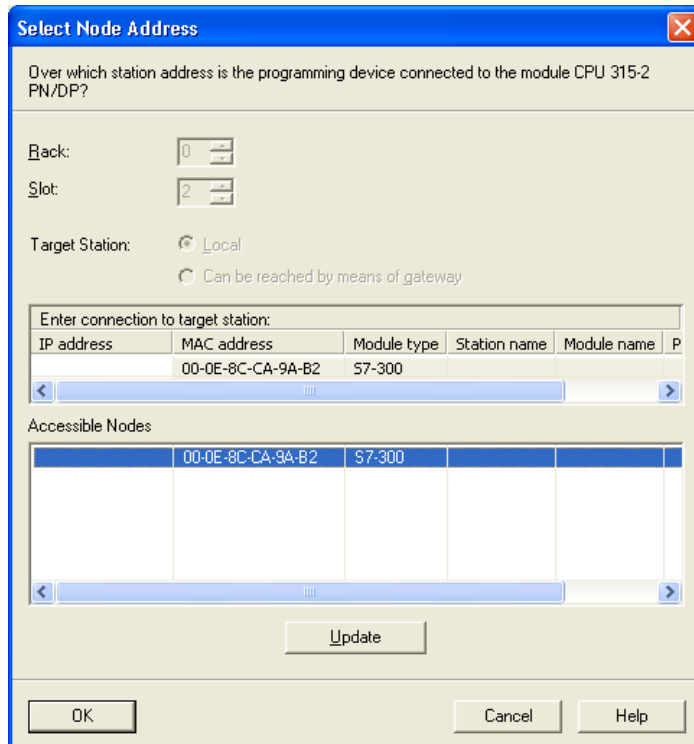

Figure 42: Select Node Address (2)

- In the **Accessible Nodes** list, select the row featuring the MAC address of the CPU, then click **OK** button.
- If no IP address has been assigned to the CPU before, the following **Download** message appears:

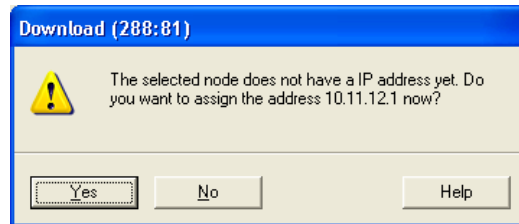

Figure 43: Select Node Address (3)

- Answer the question, whether the IP address should be assigned, with **Yes**.
- The IP address is assigned to the CPU, and the configuration is loaded to the CPU of the PLC.
- In the menu bar of the **HW Config** window choose **Station > Exit** to close **HW Config**. Answer the save prompt with **Yes**.

7.3.4 Step-by-Step Instructions for Programming in STEP 7: Display I/O Data

The following step-by-step instructions provide a simple programming example for a PLC in STEP 7. It shows, how to monitor I/O data of the M22-SWD-K22LED-B function element, which is a SmartWire-DT slave controlled by a S7-300 PLC via the EU5C-SWD-PROFINET Gateway. For this, you must first define a “data block” and an “organization block” and load them to the PLC. Then you can visualize input and output data of the M22-SWD-K22LED-B slave in STEP 7 by means of a “variable table”, and send output data to the slave too.

Prerequisites

- You have already created, configured and loaded onto the S7-300 PLC a project containing a certain SmartWire-DT slave (in this case the M22-SWD-K22LED-B function element).
- Communication between PROFINET IO and SmartWire-DT network via gateway runs smoothly, cyclic data is exchanged.
- The programming device/PC with installed STEP 7 software is connected to the S7-300 PLC.
- You know the meaning of the input and output signals (e. g. the assignment of certain Bits to certain operational states) of the concerned SmartWire-DT slave.



You will find the parameters of individual SmartWire-DT devices needed for programming in the Eaton user manual *SmartWire-DT Units*, 05/11 MN05006001Z-EN.

- The project is opened in the SIMATIC Manager.

Step-by-step instructions

1. Create data block.

- In the project tree, select the CPU.
- In the menu bar, choose **Insert > S7 Block > Data block**.

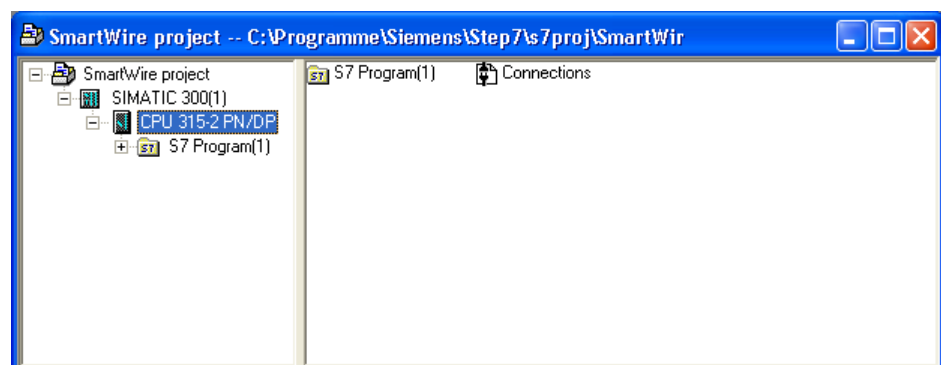

Figure 44: Project Window in SIMATIC Manager

➤ The **Properties** sheet of the data block opens.

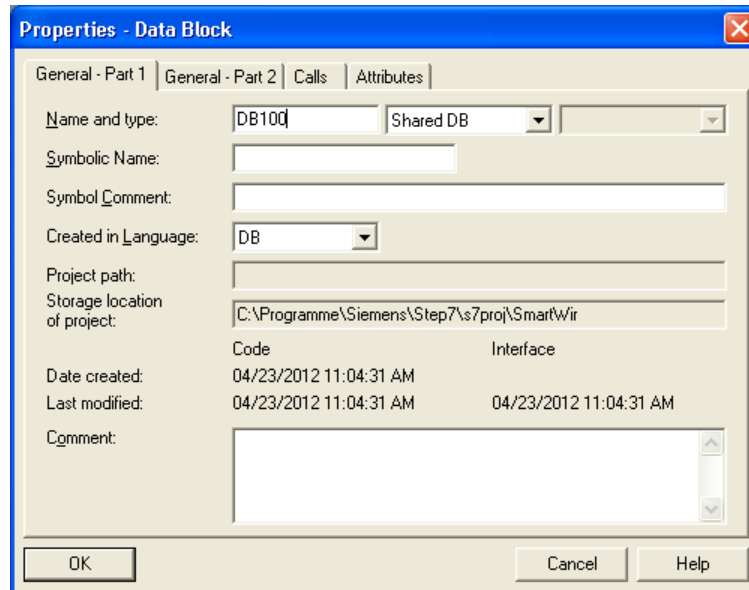

Figure 45: Create Data Block

- In the **Name and type** field of the **General – Part 1** tab, enter the name of the data block, e. g. „DB100“, then click **OK** button.
- The new data block is displayed in the **Blocks** node of the project window.

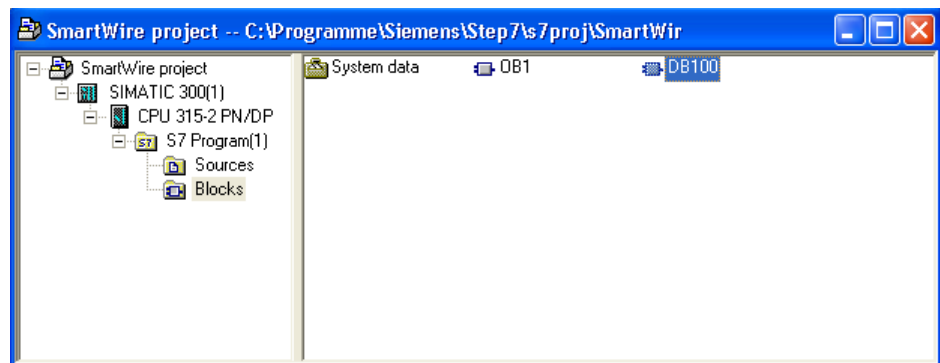

Figure 46: Data Block Created

2. Edit data block.

- Select **DB100** block.
- Double-click **DB100** block or choose **Edit > Open Object** in the menu bar.

➤ The data block is opened in the editor:

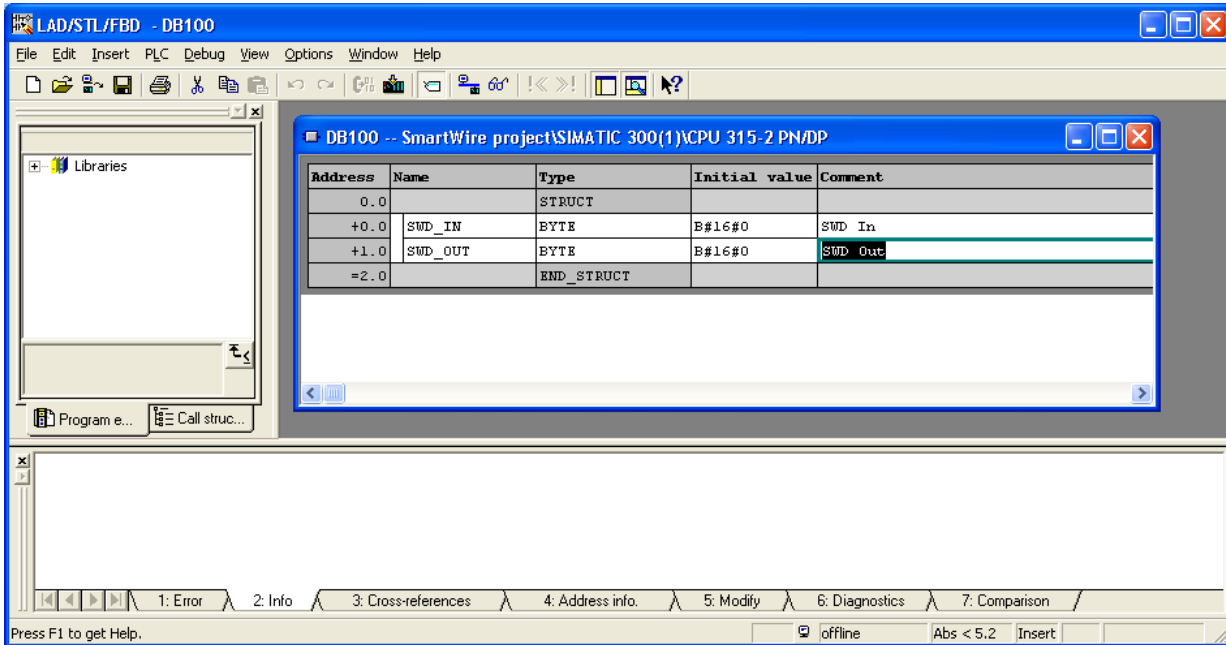

Figure 47: Edit Data Block

- Define **Name**, **Type** and **Initial value** of the elements which represent the input and output data.
 - In the menu bar of the editor, choose **File > Save**, then close the editor.
3. Edit organization block.



Note: You don't need to create a new organization block (whereas you had to create a new data block), because each project by default already includes an **OB1** organization block.

- In the **Blocks** node of the project window, select the **OB1** organization block.
- Double-click **OB1** block or choose **Edit > Open Object** in the menu bar.
- If you open the **OB1** organization block for the first time, the **Properties** sheet of the block opens.
- Close the **Properties** sheet by clicking the **OK** button.

➤ The organization block is opened in the editor:

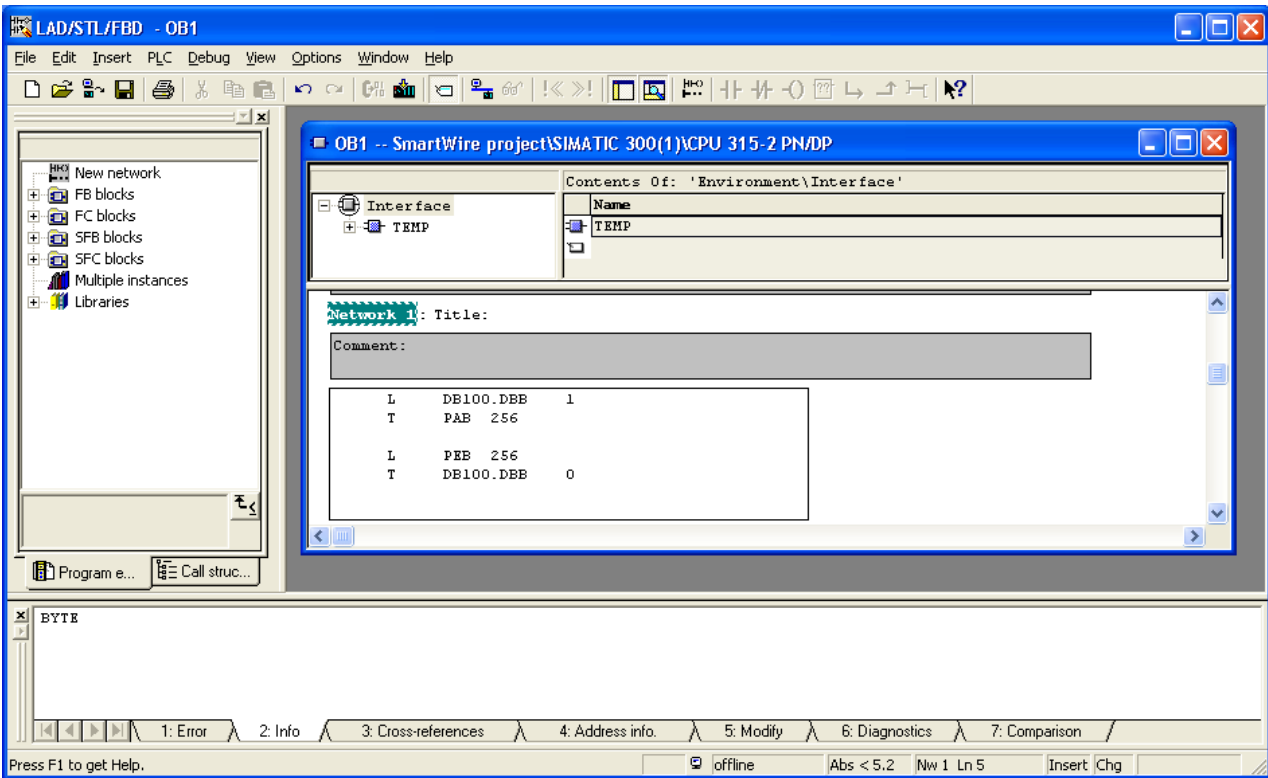

Figure 48: Edit Organization Block

- Link the elements representing the input and output data of the SmartWire-DT slave (i. e. DB100.DBB 1 and DB100.DBB 0 which you have defined in the data block) to the I/O addresses which were assigned to the SmartWire-DT slave when the project was being configured in PROFINET IO. (See section *Configure SmartWire-DT Slaves in PROFINET IO.*) If, for example, the value 256 was configured as I/O address, you must enter the programming code as shown in the picture above.
- After you have entered the code, choose **File > Save** in the menu bar of the editor, then close the editor.

4. Load blocks to S7-300 PLC.

Before you can use a variable table to monitor input and output data of the SmartWire-DT slave, you must download the code/blocks to the PLC.

- In the project tree, select **Blocks** node.

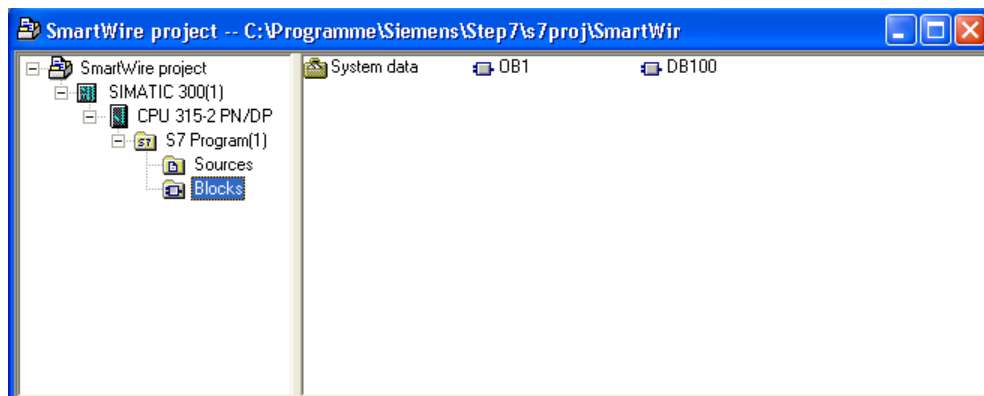

Figure 49: Select Blocks Node in SIMATIC Manager

- In the menu bar of the SIMATIC Manager, choose **PLC > Download**.
- The code/blocks are loaded to the PLC.
- 5. Create variable table.
 - In the project tree, select the CPU.

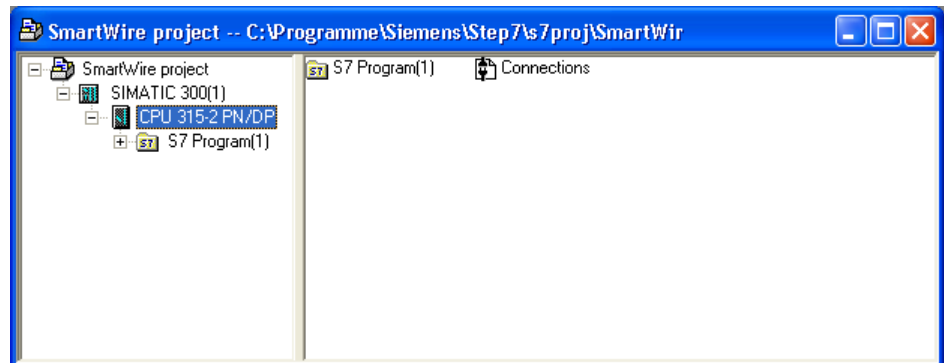

Figure 50: Selected CPU in Project Tree

- In the menu bar of the SIMATIC Manager, choose **Insert > S7 Block > Variable Table**.
- The **Properties** sheet of the variable table opens.

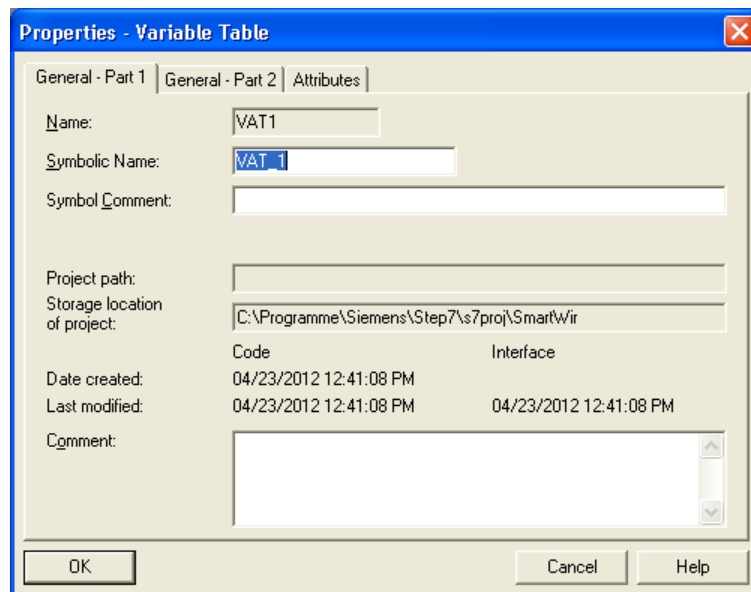

Figure 51: Create Variable Table

- In the **Symbolic Name** field of the **General – Part 1** tab, enter the name of the table, e. g. „ VAT_1“, then click **OK** button.

- The new variable table is displayed in the **Blocks** node of the project window:

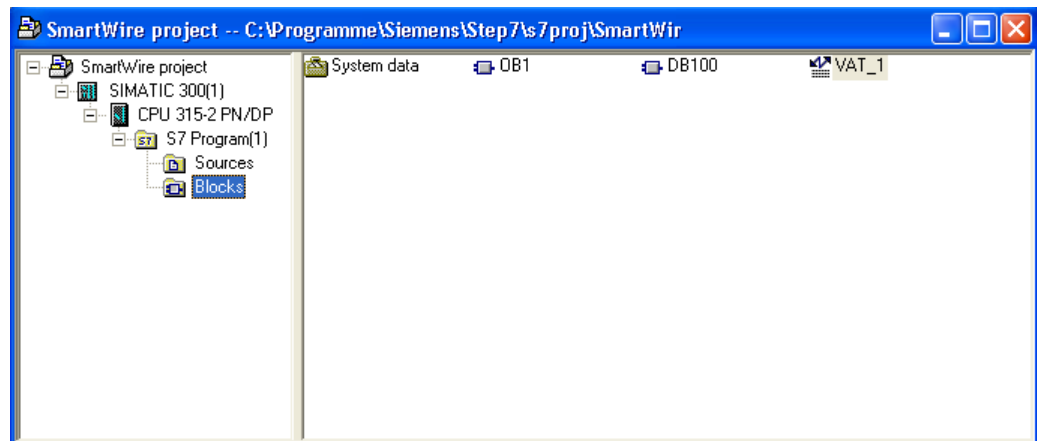

Figure 52: Variable Table Created

6. Edit Variable Table.

- Select the variable table.
- Double-click the variable table or choose **Edit > Open Object** in the menu bar.
- The variable table is opened in the editor:

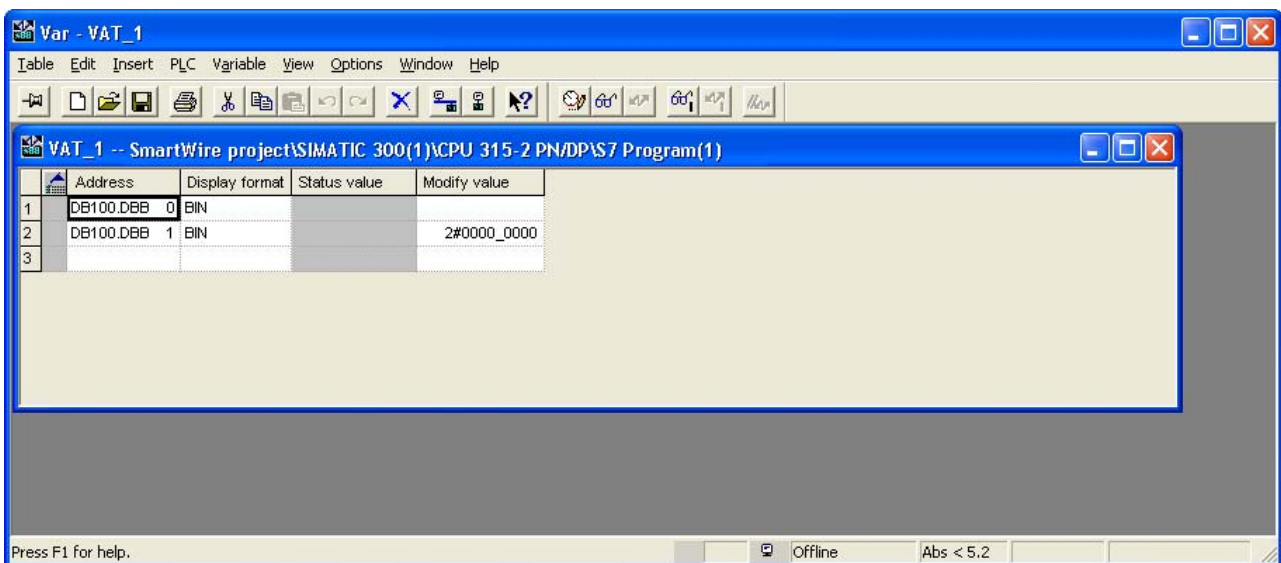



Figure 53: Edit Variable Table

- Fill in the **Address** and **Display format** columns as shown in the picture above.
 - In the menu bar of the editor, choose **Table > Save**.
- #### 7. Display I/O data.
- In the menu bar of the editor, choose **Variable > Monitor**, or click  button in the toolbar of the editor.

- An online connection to the S7-300 PLC of this project is automatically established, and signals currently sent by the SmartWire-DT slave are displayed in the **Status value** column.

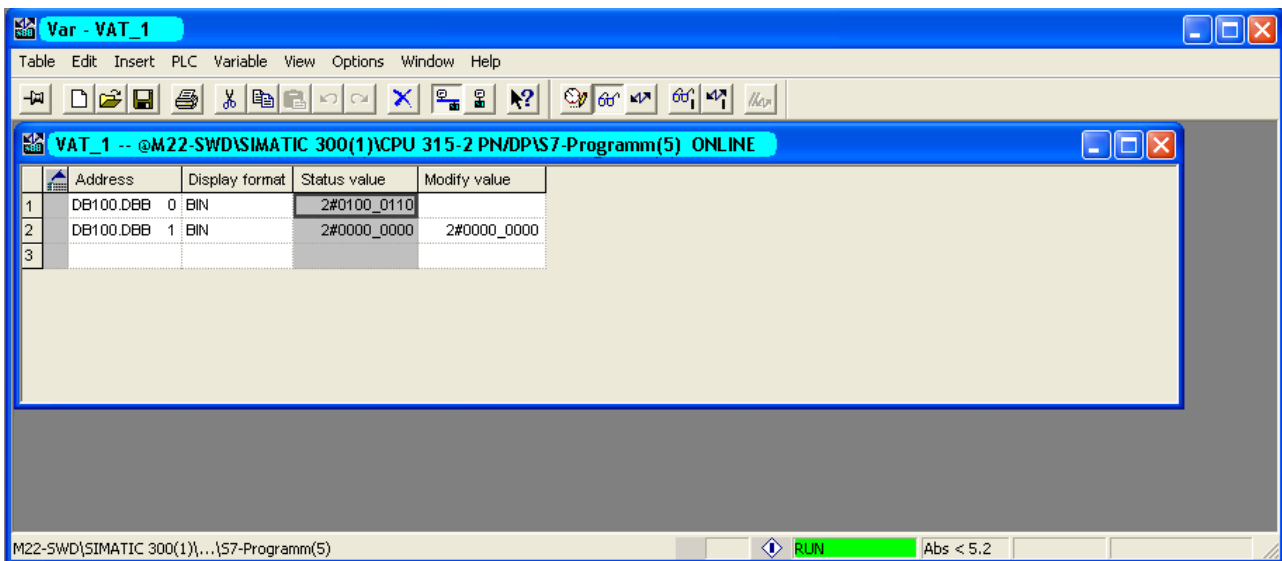

Figure 54: Monitor Input Data

If an event is triggered at the SmartWire-DT slave, the **Status value** of the DB100.DBB 0 element (which represents the input data) changes:

- Push one of the buttons of the M22-SWD-K22LED-B slave device.
- The corresponding Bit in the **Status value** column changes from 0 to 1.



Information on the assignment of certain Bits to certain operational states, and other parameters needed for programming SmartWire-DT slaves, can be found in the Eaton user manual *SmartWire-DT Units*, 05/11 MN05006001Z-EN.

If the **Modify value** of the DB100.DBB 1 element (which represents the output data) is changed, an event at the SmartWire-DT slave can be triggered:

- In the variable table, change the last Bit of the **Modify value** of the DB100.DBB 1 element from 0 to 1.

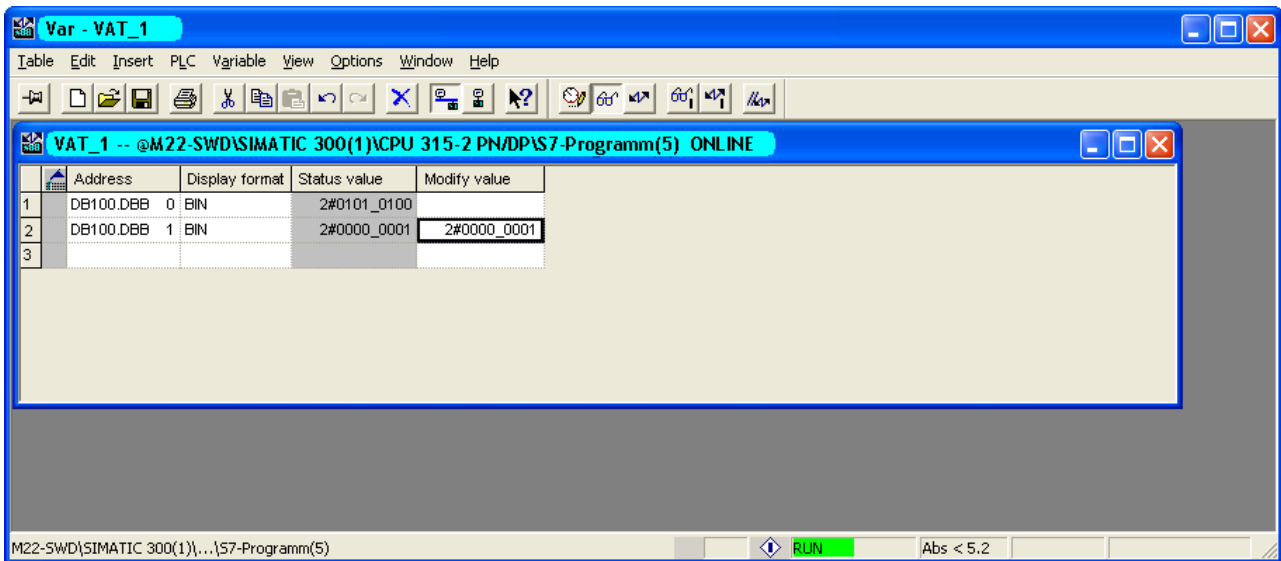



Figure 55: Modify Value

- In the toolbar of the editor, click  button.
- The LED at the M22-SWD-K22LED-B slave device lights up.

7.3.5 Adding SmartWire-DT Slaves Later

If you are not sure about the final SmartWire-DT topology, and may wish to add SmartWire-DT slaves later, adding a placeholder (dummy module) in the appropriate position in the SmartWire-DT network is recommended. This is especially useful in STEP 7, since the **HW Config** tool does not allow the adding of stations between occupied module locations.

- During configuration of the project in the engineering tool, position the permanent SmartWire-DT slaves in the correct order and add the **Reserved** (stored in the **Other elements** folder) element at the required position.

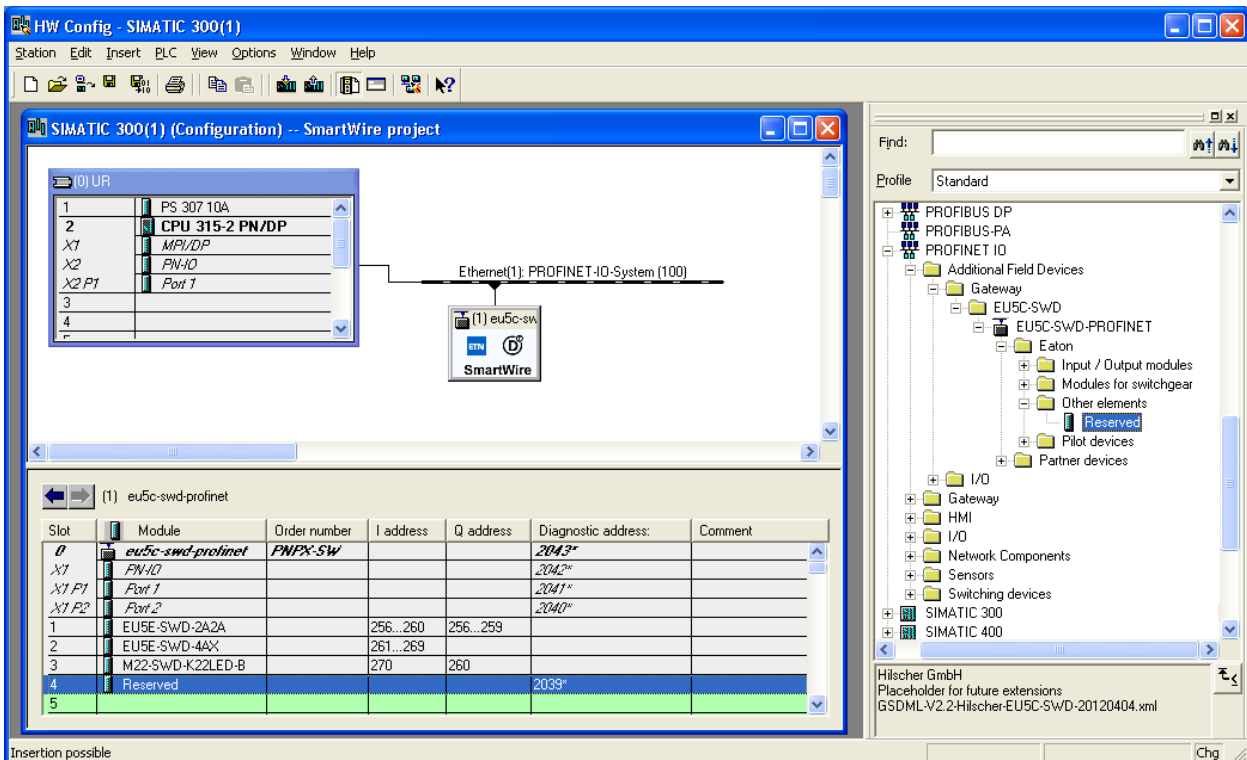

Figure 56: Add Placeholder

- The placeholder reserves a SmartWire-DT slave address for the SmartWire-DT slave which is to be added later.
- Save the project, transfer it to the PLC. Then switch the PLC to RUN mode.
- After the PROFINET IO configuration is received from the PLC, the SmartWire-DT gateway addresses the slaves automatically, taking the placeholder into account.

7.3.6 Acyclical Data Communication S7-300 PLC

SmartWire-DT slaves – such as the PKE-SWD-32 module for the electronic motor-protective circuit-breaker – also supply acyclical data in addition to the cyclical data. The function blocks **SFB52 RDREC** (read record) and **SFB53 WRREC** (write record) are used in STEP 7 for reading and writing acyclical data.

The reference to the required slave is implemented with these function blocks via the parameters **ID** and **Index**.



For further information on handling these function blocks, please refer to the STEP 7 documentation.

The address of the SmartWire-DT slave, with which communication is to be established, is set at the parameter **ID**. The **Index** parameter addresses the V1 object. The first object is assigned number 1, the second 2 etc. On the SmartWire-DT slave PKE-SWD-32, the object 1 supplies the current value **I_{rel}**.

For further information on acyclical data communication, see *Acyclical Communication* section on page 84.

7.3.7 Using STEP 7 to Assign Device Name or IP Address on the Gateway

You can use STEP 7 and your programming device/PC to assign to your gateway a new IP address or a new device name – independently from the PROFINET IO configuration.

Prerequisites

- The gateway is connected to power supply.
- The gateway is connected via Ethernet to the programming device/PC and the STEP 7 software.
- If you want to change the IP address of the gateway, the gateway must not be in a state of cyclic data exchange with the PROFINET IO controller.

Step-by-step instructions

- Open **HW Config** window for the project.
- In the menu bar of the **HW Config** window, choose **PLC > Ethernet > Edit Ethernet Node**.
- A blank **Edit Ethernet Node** dialog box opens:

Figure 57: Edit Ethernet Node (1)

- Below **Nodes accessible online**, click **Browse...** button.

- The **Browse Network** dialog box opens. After a short while, all found nodes are displayed:

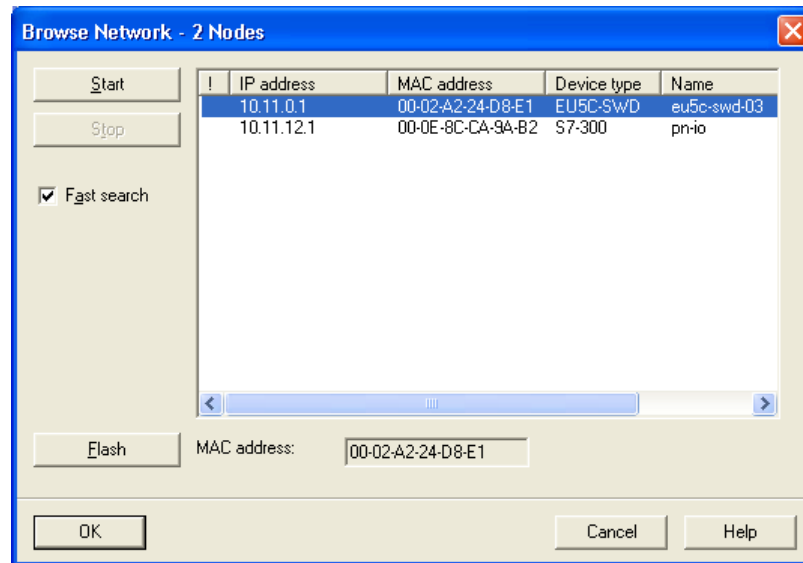

Figure 58: Browse Network

- Select the entry for the gateway, then click **OK** button.



Note: You can make the **SF** LED of the gateway flash, by clicking the **Flash** button in this dialog box. This may help you, to physically identify the gateway in a complex installation. Click **Stop Flash** button to switch off the LED.

- The **Browse Network** dialog box closes, and the current address parameter of the gateway are taken over into the **Edit Ethernet Node** dialog box:

Figure 59: Edit Ethernet Node (2)

- If you want to change the IP Address:
Enter the appropriate values in the **IP address** and **Subnet mask** fields, then click **Assign IP Configuration** button.
- The IP address is transferred to the gateway and is stored in the gateway.
- If you want to change the device name:
Enter the new name in the **Device name** field, then click **Assign name** button.
- The device name is transferred to the gateway and is stored in the gateway.
- Click **Close** button to leave the **Edit Ethernet Node** dialog box.



Important!

Please note, that you also have to change the parameters in the PROFINET IO configuration accordingly, and that you have to load the adjusted configuration to the S7-300 PLC.

8 PROFINET IO Data Communication

8.1 Acyclical Communication

8.1.1 Address Mapping

For acyclic communication, the read/write record services of the PROFINET IO controller are in the EU5C-SWD-PROFINET Gateway converted to SmartWire-DT read/write services and forwarded to the SmartWire-DT slaves. An address mapping enables the PROFINET IO Controller to access the SmartWire-DT slaves via the gateway.

The following figure depicts the mapping of the PROFINET IO slot, subslot and index to SmartWire-DT slave and index.

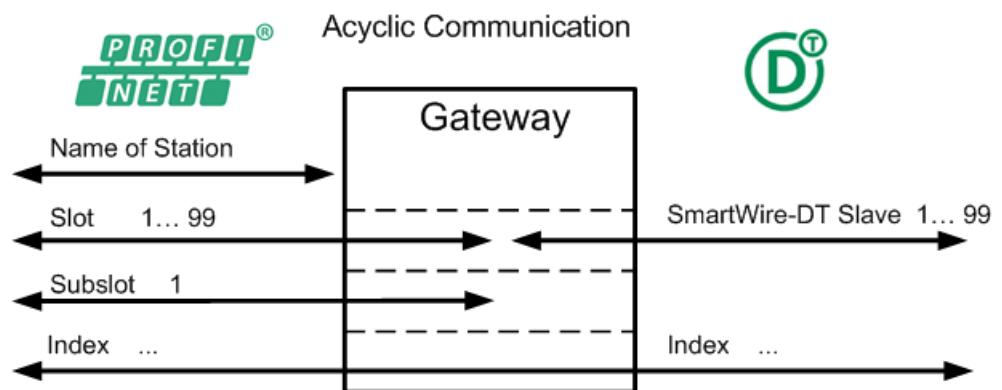

Figure 60: Acyclic Data Address Mapping

The gateway is addressed by the PROFINET IO **name of station**. This makes it possible to address devices in the PROFINET IO network.

The numbering of the slots corresponds to the sequence of the SmartWire-DT slaves, i. e. **Slot 1** is assigned to the first slave etc.

The **Subslot** in PROFINET IO and in SmartWire-DT is always 1.

The **Index** is passed on unaltered from SmartWire-DT to PROFINET IO. The meaning of the indexes depends on the individual SmartWire-DT slaves.

8.1.2 Error Detection and Error Codes

The following figure shows at which points error detection is possible in acyclic communication.

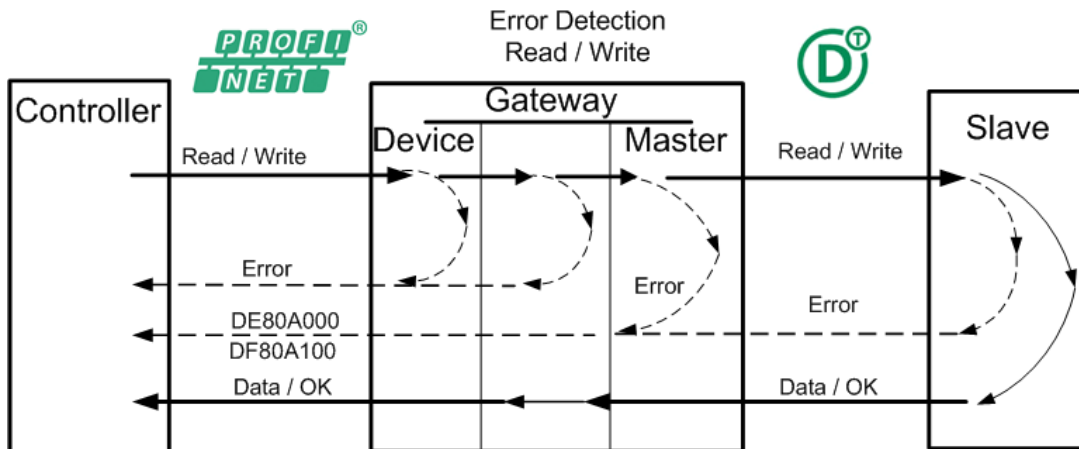

Figure 61: Acyclic Data Error Detection

Errors detected in the gateway (PROFINET IO device) are reported as normal PROFINET IO errors to the controller.

All errors, except addressing errors, which are detected on SmartWire-DT (master or slave) are reported with error code 0xDE80A000 (read) or 0xDF80A100 (write) to the PROFINET IO controller.

Error detection by the gateway for read/write records:

An error code, e. g. 0xDE80B000, consists of an ErrorCode (DE = IODReadRes), ErrorDecode (80 = PNIO RW), ErrorCode1 (B0 = invalid index) and ErrorCode2 (00 = not defined).

Error codes for read requests

All error messages supported by the gateway concerning **read requests** start with:

ErrorCode_{DE} = IODReadRes = negative response to a read request, followed by:

ErrorDecode₈₀ = PNORW = user error.

A description of ErrorCode1, which conveys the actual message, is provided in the following table. ErrorCode2 is not defined.

Error message for read request	ErrorCode1	Meaning
0xDE80A0xx	A0	Application error in SmartWire-DT
0xDE80B0xx	B0	Access invalid index
0xDE80B2xx	B2	Access invalid slot/subslot
0xDE80B3xx	B3	Access type conflict
0xDE80B4xx	B4	Access invalid area / API
0xDE80B5xx	B5	Access state conflict
0xDE80B6xx	B6	Access denied
0xDE80B7xx	B7	Access invalid range of a parameter/value
0xDE80B8xx	B8	Access invalid parameter
0xDE80B9xx	B9	Access invalid type
0xDE80BAxx	BA	Access backup
0xDE80BBxx	BB	Access user specific 7
0xDE80BCxx	BC	Access user specific 8
0xDE80BDxx	BD	Access user specific 9
0xDE80BExx	BE	Access user specific 10
0xDE80BFxx	BF	Access user specific 11
0xDE80C0xx	C0	Resource constrain conflict
0xDE80C2xx	C2	Resource busy
0xDE80C3xx	C3	Resource unavailable
0xDE80C4xx	C4	Resource not specified 1
0xDE80C5xx	C5	Resource not specified 2
0xDE80C6xx	C6	Resource not specified 3
0xDE80C7xx	C7	Resource not specified 4
0xDE80C8xx	C8	Resource user specific 12
0xDE80C9xx	C9	Resource user specific 13
0xDE80CAxx	CA	Resource user specific 14
0xDE80CBxx	CB	Resource user specific 15
0xDE80CCxx	CC	Resource user specific 16
0xDE80CDxx	CD	Resource user specific 17
0xDE80CExx	CE	Resource user specific 18
0xDE80CFxx	CF	Resource user specific 19

Table 18: Acyclic Data Error Codes For Read Requests

Error codes for write requests

All error messages supported by the gateway concerning **read requests** start with:

ErrorCode_{DF} = IODWriteRes = negative response to a write request, followed by:

ErrorDecode₈₀ = PNORW = user error.

A description of ErrorCode1, which conveys the actual message, is provided in the following table. ErrorCode2 is not defined.

Error message for write request	ErrorCode1	Meaning
0xDF80 A1 xx	A1	Application error in SmartWire-DT
0xDF80 B0 xx	B0	Access invalid index
0xDF80 B2 xx	B2	Access invalid slot/subslot
0xDF80 B3 xx	B3	Access type conflict
0xDF80 B4 xx	B4	Access invalid area / API
0xDF80 B5 xx	B5	Access state conflict
0xDF80 B6 xx	B6	Access denied
0xDF80 B7 xx	B7	Access invalid range of a parameter/value
0xDF80 B8 xx	B8	Access invalid parameter
0xDF80 B9 xx	B9	Access invalid type
0xDF80 BA xx	BA	Access backup
0xDF80 BB xx	BB	Access user specific 7
0xDF80 BC xx	BC	Access user specific 8
0xDF80 BD xx	BD	Access user specific 9
0xDF80 BE xx	BE	Access user specific 10
0xDF80 BF xx	BF	Access user specific 11
0xDF80 C1 xx	C1	Resource constrain conflict
0xDF80 C2 xx	C2	Resource busy
0xDF80 C3 xx	C3	Resource unavailable
0xDF80 C4 xx	C4	Resource not specified 1
0xDF80 C5 xx	C5	Resource not specified 2
0xDF80 C6 xx	C6	Resource not specified 3
0xDF80 C7 xx	C7	Resource not specified 4
0xDF80 C8 xx	C8	Resource user specific 12
0xDF80 C9 xx	C9	Resource user specific 13
0xDF80 CA xx	CA	Resource user specific 14
0xDF80 CB xx	CB	Resource user specific 15
0xDF80 CC xx	CC	Resource user specific 16
0xDF80 CD xx	CD	Resource user specific 17
0xDF80 CE xx	CE	Resource user specific 18
0xDF80 CF xx	CF	Resource user specific 19

Table 19: Acyclic Data Error Codes For Write Requests

8.2 Alarms and Diagnosis Controlled by the Gateway

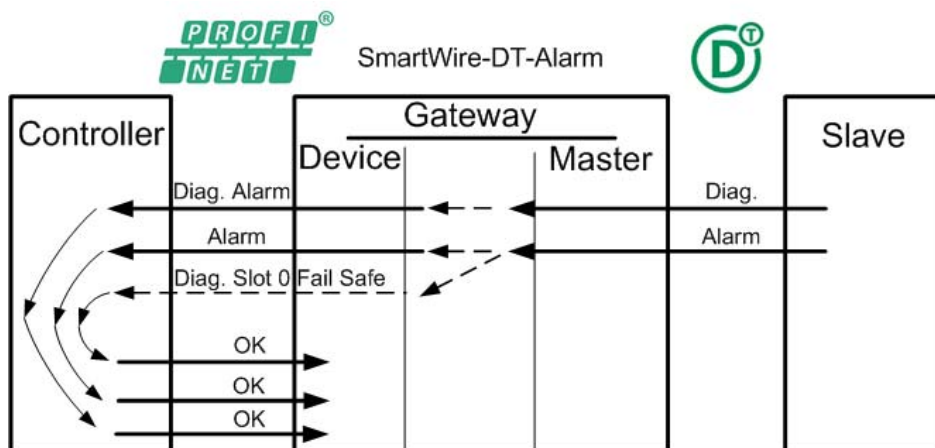

Figure 62: Diagnosis/Alarms

Alarms can be process alarms (PA) or diagnosis alarms (DA).

Process alarms are not issued by the gateway.

Diagnosis alarms can be:

- Return of submodule alarm
- Pull alarm
- Plug alarm
- Diagnosis

Return of submodule alarm

Alarm issued for every plugged SmartWire-DT slave when SmartWire-DT returns from **fail safe** back to **run normal** state.

Pull alarm

Removal (pulling) or failure of a slave in the SmartWire-DT network leads to a pull alarm in PROFINET IO.

Plug alarm

Adding (plugging) or reinstalling a slave in the SmartWire-DT network leads to a plug alarm only if the concerned slave device is included in the target configuration.

Adding a slave which is not included in the target configuration will not cause an alarm.



Note: After having added a new slave device to the SmartWire-DT network, you need to disconnect the PROFINET IO from the gateway and read-in the new target configuration of the SmartWire-DT network (see *Reading the SmartWire-DT Configuration* section on page 41). Please note, that you also need to add the new slave to the PROFINET IO configuration.

Diagnosis

Diagnosis data issued by a SmartWire-DT slave is forwarded to the PROFINET IO controller by the gateway using the following parameters:

Parameter	Value
Slot	Slot 0 = gateway reports Slot 1...99 = individual SmartWire-DT slaves
SubSlot	is always 1
Channel Number	0x8000 (= Submodule)
Channel Property	is always 0
ChannelErrorType	see subsequent table

Table 20: Diagnosis Parameters

ChannelErrorType:

PROFINET IO ChannelErrorType	SmartWire-DT Diagnosis code	Meaning	Slot
0x0107	-	SmartWire-DT is in state fail safe	0 (gateway)
0x0002	0x02	Supply voltage too low	1...99 (individual SWD-slaves)
0x0004	0x13	Short-circuit/overload at supply voltage	
0x0005	0x01	Temperature too high	
0x0007	0x17	Out-of-range high reading on at least one temperature input	
0x0008	0x18	Out-of-range low reading on at least one temperature input	
0x0013	0x03	No communication with host system	
0x0100	0x14	Internal error	
0x0101	0x10	At device M22: contact in undefined position / contact in the middle position for longer than four seconds	
0x0102	0x11	At device M22: contact short-circuit	
0x0103	0x12	At device M22: contact resistance too high	
0x0105	0x16	S0 power meters invalid	
0x0106	0x15	No unambiguous position of the 1-0-A switch (auto/manual switch) for more than four seconds	

Table 21: Diagnosis ChannelErrorType

9 Updating Firmware

The EU5C-SWD-PROFINET Gateway is shipped with its most recent firmware already loaded. The integrated web server of the gateway provides a function to update the firmware of the gateway by HTTP via its Ethernet interface. All you need is a PC with an ordinary web browser, connected to the gateway via the Ethernet network.

9.1 Prerequisites

- The gateway is connected to a power supply.
- The gateway is connected to an IP network via its Ethernet interface.
- PC with web browser connected to the IP network.
- The IP address of the gateway is compatible to the Ethernet subnet of the PC.
- You know the IP address of the gateway and user name and password needed for accessing the firmware update and reset functions of the web server.

Default authentication parameters are:

User Name: admin

Password: admin



Note: The current version of the firmware does not provide options to customize the user authentication of the web server by creating own groups, users or passwords.

IP address of gateway

On shipment, the default IP address of the gateway is 0.0.0.0.

In principle, the gateway receives its IP address temporarily from the PROFINET IO controller via DCP protocol, and on each restart anew. A statically stored IP address can also be assigned to the gateway by the DCP protocol. The DCP protocol is standardized and usually supported by PROFINET IO engineering tools.

Apart from address assignment by the PROFINET IO controller, you can assign the IP address of the gateway via DCP by using one of the following tools:

- **Hilscher Ethernet Device Configuration Tool.**
An installer for this program is stored on the product DVD in the directory `Software\EnDeviceCfg`. (It can also be installed by using the auto-start menu of the Product DVD.)
For further information about this tool, please refer to the operating instruction manual *Ethernet Device Configuration*, which is stored on the product DVD in the directory `Documentation\english\Ethernet Device Configuration`.
- **STEP 7.** For further information, please refer to section *Using STEP 7 to Assign Device Name or IP Address on the Gateway* on page 81.

9.2 Step-by-Step Instructions for Updating Firmware

- Start your web browser.
- In the address bar of your browser, enter URL:
`http://<IP address>/fwupdate`
- The user authentication dialog opens.
- Enter user name **admin** and password **admin**.



Note: The current version of the firmware does not provide options to customize the user authentication by creating own groups, users or passwords.

- The following web page opens:

Firmware

Firmware Identification

Channel	Name	Version	Date
0	SmartWire-DT PROFINET	0.9.4.1	9.5.2012

Firmware Update

Choose the new firmware file (.nxf) you want to install:

Submit your file by clicking on "transfer". The transfer will take a few seconds.

WARNING: Do not interrupt power or disconnect cable from the system while the transfer is in progress!

Figure 63: Firmware Update by HTTP (as depicted in Internet Explorer)

The **Firmware Identification** section displays the following information:

- Channel number (port number)
- Name of loaded firmware
- Firmware version
- Date of firmware

The **Firmware Update** section features the following control elements:

Control element	Function
Selection field	Shows selected file and its location.
Browse...	Opens the file selection dialog.
Transfer	Uploads selected firmware file to device.
Cancel	Cancels firmware update and clears selection field.

Table 22: Controls in Firmware Update Page

- Click **Browse...** button, to open a dialog box for selecting the firmware file.

- Select the firmware file and close the dialog box.



Note: The filename extension of firmware files is `.nxf`

- Path and name of the selected file are displayed in the field next to the **Browse...** button.
- Click **Transfer** button to load the new firmware file to the gateway.



NOTICE

Hazard of device damage by power failure during file transfer!

Do not interrupt the power supply during transfer of the firmware file. A power failure while switching from the old to the already stored new firmware can cause severe malfunction of the device.

- After you have started the upload by clicking the **Transfer** button, the validity of the firmware file is being checked by the system. If the file fails the validity check, the file will not be stored in the gateway and an error message will be displayed on the web page. If the file passes, a **Transfer succeeded** message will be displayed.



Note: After successful transfer, you need to reset the gateway in order to start up the new firmware.

9.3 Resetting Gateway

- In the address bar of your browser, enter URL:
`http://<IP address>/reset`
- If the user authentication dialog opens, enter user name **admin** and password **admin**.
- The following web page opens:

Device Reset

Firmware is being restarted and connections may be interrupted or time out!

Ethernet connection may be lost if IP parameters are not stored permanently!

Please confirm you want to reset the device.

Figure 64: Reset by HTTP (as depicted in Internet Explorer)



Important!

Please note the following consequences of a reset:

- The firmware is being restarted and connections will be interrupted or timed out.
- I/O bus communication is being stopped.
- The IP connection gets lost, if the gateway is not connected to a PROFINET IO controller and the IP address has not been permanently stored in the gateway.

- Activate the checkbox in front of **Please confirm...** to acknowledge that you want to reset the device.
- Then click **Submit** button to start the reset.

You can use the **Cancel** button to uncheck the checkbox in front of **Please confirm...**

10 Technical Data

10.1 Technical Data EU5C-SWD-PROFINET Gateway

Category	Parameter	Value
General	Part number	9233.920
	Dimensions (W x H x D)	35 x 90 x 127 mm
	Weight	160 g
	Mounting	Top hat rail 35 mm (IEC/EN 60715)
	Mounting position	Vertical
	Standards	IEC/EN 61131-2
	Communication controller	netX 50 processor
	Diagnostic interface	Mini-USB
	Integrated memory	8 MB SDRAM 4 MB serial Flash EPROM
Ambient mechanical conditions	Protection type (IEC/EN 60529, EN50178, VBG 4)	IP20
	Vibrations (IEC/EN 61131-2:2008)	Constant amplitude 3.5 mm: 5 – 9 Hz Constant acceleration 1 g: 9 – 150 Hz
	Mechanical shock resistance (IEC/EN 60068-2-27)	Semi-sinusoidal 15 g/11 ms: 9 Shocks
	Drop to (IEC/EN 60068-2-31)	Drop height: 50 mm
	Free fall, packaged (IEC/EN 60068-2-32)	Drop height: 1 m
Ambient climatic conditions	Operating ambient temperature (IEC 60068-2)	-25...+55 °C
	Condensation	Prevent by suitable measures
	Storage	-40...+70 °C
	Relative humidity, non-condensing (IEC/EN 60068-2-30)	5...95 %
Electromagnetic compatibility (EMC)	Pollution degree	2
	Electrostatic discharge (IEC/EN 61131-2:2008)	Air discharge (Level 3): 8 kV Contact discharge (Level 2): 4 kV
	Electromagnetic fields (IEC/EN 61131-2:2008)	80 – 1000 MHz: 10 V/m 1.4 – 2 GHz: 3 V/m 2 – 2.7 GHz: 1 V/m
	Radio interference suppression (SmartWire-DT)	EN 55011 Class A
	Burst (IEC/EN 61131-2:2008, Level 3)	Supply cables: 2 kV PROFINET bus cable: 1 kV SmartWire-DT cables: 1 kV
	Surge (IEC/EN 61131-2:2008, Level 1)	Supply cables: 0,5 kV PROFINET bus cable: 1 kV
	Radiated RFI (IEC/EN 61131-2:2008, Level 3)	0.15 – 80 MHz, 10 V, 80% AM / 1 KHz
Supply voltage U _{AUX}	Rated operational voltage	24 V DC -15 % +20 %

Category	Parameter	Value
	Input voltage residual ripple	≤ 5 %
	Protection against polarity reversal	Yes
	max. current I_{max}	3 A Note: If contactors with a total power consumption > 3 A are connected, a power feeder module EU5C-SWD-PF1/2 has to be used.
	Short-circuit strength	No, external fuse FAZ Z3
	Heat dissipation	Typ. 1 W
	Potential isolation	No
	Rated operating voltage of 24-V-DC slaves	Typical U_{AUX} -0,2 V
Supply voltage U_{POW}	Supply voltage	24 V DC -15 % +20 %
	Input voltage residual ripple	≤ 5 %
	Protection against polarity reversal	Yes
	Rated operational current I	111 mA (with two participants)
	Heat dissipation at 24 V DC	2.66 W (with two participants)
	Potential isolation between U_{POW} and 15-V-SmartWire-DT supply voltage	No
	Bridging voltage dips	10 ms
	Repeat rate	1 s
	Status display	Yes
SmartWire-DT supply voltage	Rated operational voltage U_e	15 V ± 3 %
	max. current I_{max}	0.7 A Note: If contactors with a total power consumption > 0.7 A are connected, a power feeder module EU5C-SWD-PF2 has to be used.
	Short-circuit strength	Yes
Connection supply voltages	Connection type	Push-in terminals
	solid	0.2 – 1.5 mm ² (AWG 24 – 16)
	Flexible with ferrule	0.25 – 1.5 mm ²
SmartWire-DT network	Participant type	SmartWire-DT master
	SmartWire-DT Master ASIC	SWD-80P-RS485
	Number of SmartWire-DT slaves	99
	Baud rate	125 / 250 kBd
	Address setting	Automatic
	Status display	SmartWire-DT master: SWD LED, duo color red/green Configuration: Config LED, duo color red/green

Category	Parameter	Value
	Connections	Plug, 8-pole
	Plug connectors	Blade terminal SWD4-8MF2
PROFINET IO network	Function	PROFINET IO Device (Slave)
	Baud rate	100 MBit/s
	Interface type	100 BASE-TX
	Half duplex/full duplex	Supported
	Auto-Negotiation	Supported
	Auto-Crossover	Supported
	Address setting	Automatically via PROFINET IO
	Status display	PROFINET IO device: APL, SF, BF LEDs, duo color red/green
	Connector socket	2 x RJ45
	Connector plug	RJ45
	Potential isolation	Yes

Table 23: Technical Data EU5C-SWD-PROFINET Gateway

10.2 PROFINET IO Device (Slave)

Parameter	Description
Maximum number of cyclic input data	800 bytes
Maximum number of cyclic output data	642 bytes
Maximum number of cyclic input/output data in sum	1000 bytes
Supported protocols	RTC – Real Time Cyclic Protocol, Class 1 and 2 (unsynchronized) RTA – Real Time Acyclic Protocol DCP – Discovery and configuration Protocol CL-RPC – Connectionless Remote Procedure Call LLDP – Link Layer Discovery Protocol SNMP – Simple Network Management Protocol
Used Protocols (subset)	UDP, IP, ARP, ICMP (Ping)
Topology recognition	LLDP, SNMP V1, MIB2, physical device
VLAN- and priority tagging	Yes
Context Management by CL-RPC	Supported
Minimum cycle time	1 ms for RTC1 and RTC2
Baud rate	100 MBit/s
Data transport layer	Ethernet II, IEEE 802.3
Limitations	RT over UDP not supported Multicast communication not supported Only one device instance is supported DHCP is not supported RT Class 2 synchronized (IRT “flex”) is not supported RT Class 3 synchronized not supported FastStartUp is not supported Media Redundancy (except MRP client) is not supported Access to the submodule granular status bytes (IOCS) is not supported The amount of configured IO-data influences the minimum cycle time that can be reached Supervisor-AR is not supported, Supervisor-DA-AR is supported Only 1 Input-CR and 1 Output-CR are supported Multiple WriteRequests are not supported

Table 24: Technical Data PROFINET IO Device

10.3 Compatibility of SmartWire-DT Devices and Gateway

SmartWire-DT slaves	EU5C-SWD-PROFINET Gateway Firmware: E030D0U0.nxf Firmware version number: 1.0.x.x Hardware revision number: 3 GSDML device description file: GSDML-V2.25-Hilscher-EU5C-SWD-201206xx.xml
I/O modules	
EU5E-SWD-8DX	√
EU5E-SWD-4D4D	√
EU5E-SWD-4D2R	√
EU5E-SWD-4DX	√
EU5E-SWD-X8D	√
EU5E-SWD-4AX	√
EU5E-SWD-2A2A	√
EU5E-SWD-4PT	√
DIL/PKE modules	
DIL-SWD-32-001	√
DIL-SWD-32-002	√
PKE-SWD-32 Profile 1, 2, 3	√
PKE modules	
PKE-SWD Profile 1, 2, 3	√
Circuit breakers	
NZM-XSWD-704 Profile 1, 2, 3, 4	√
RMQ modules	
M22-SWD-K11	√
M22-SWD-K11LED-B	√
M22-SWD-K11LEDC-B	√
M22-SWD-K11LEDC-G	√
M22-SWD-K11LEDC-R	√
M22-SWD-K11LEDC-W	√
M22-SWD-K11LED-G	√
M22-SWD-K11LED-R	√
M22-SWD-K11LED-W	√
M22-SWD-K22	√
M22-SWD-K22LED-B	√
M22-SWD-K22LEDC-B	√
M22-SWD-K22LEDC-G	√
M22-SWD-K22LEDC-R	√
M22-SWD-K22LEDC-W	√
M22-SWD-K22LED-G	√
M22-SWD-K22LED-R	√
M22-SWD-K22LED-W	√
M22-SWD-KC11	√
M22-SWD-KC22	√
M22-SWD-LED-B	√
M22-SWD-LEDC-B	√

SmartWire-DT slaves	EU5C-SWD-PROFINET Gateway Firmware: E030D0U0.nxf Firmware version number: 1.0.x.x Hardware revision number: 3 GSDML device description file: GSDML-V2.25-Hilscher-EU5C-SWD-201206xx.xml
M22-SWD-LEDC-G	√
M22-SWD-LEDC-R	√
M22-SWD-LEDC-W	√
M22-SWD-LED-G	√
M22-SWD-LED-R	√
M22-SWD-LED-W	√
Soft starter	
DS7-SWD PKE1	√
DS7-SWD PKE2	√
DS7-SWD PKE3	√
DS7-SWD PKE1-8Bit	√
DS7-SWD PKE2-8Bit	√
DS7-SWD PKE3-8Bit	√
DS7-SWD PKE1-PD 2x16Bit	√
DS7-SWD PKE2-PD 2x16Bit	√
DS7-SWD PKE3-PD 2x16Bit	√
DS7-SWD 8Bit	√
DS7-SWD PD 2x16Bit	√
Partner devices	
Phoenix Contact EM SWD-Adapter	√
Wöhner WOE-SWD-ECS3D2D	√
Wöhner WOE-SWD-AEL1DX	√
Wöhner WOE-SWD-CL9AX	√
Universal modules	
M22-SWD-NOP	√
M22-SWD-NOPC	√
Other elements	
Placeholder module (Reserved)	√

Table 25: Compatibility of Devices

11 Annex

11.1 List of Figures

Figure 1: Data Flow EU5C-SWD-PROFINET Gateway	20
Figure 2: Front View EU5C-SWD-PROFINET Gateway	25
Figure 3: LEDs EU5C-SWD-PROFINET Gateway	26
Figure 4: Pinning of the Ethernet Interface (RJ45)	29
Figure 5: Mounting Principle of the Gateway	32
Figure 6: Hook Gateway to Upper Railing	32
Figure 7: Hook Gateway to Lower Railing	33
Figure 8: Gateway is Clamped to Top Hat Rail	33
Figure 9: Unhook Gateway	34
Figure 10: Gateway Power Supply	36
Figure 11: Connecting SmartWire-DT to Gateway	37
Figure 12: Connecting PROFINET IO to Gateway	38
Figure 13: Create New Project in SIMATIC Manager	46
Figure 14: PLC Added to the Project	47
Figure 15: Hardware Configuration Window	47
Figure 16: Install GSD Files Dialog Box	48
Figure 17: Select GSDML File	48
Figure 18: Installed GSDML File	49
Figure 19: Added Rail	50
Figure 20: Added Power Module	51
Figure 21: Add CPU	52
Figure 22: Added CPU	53
Figure 23: Add PROFINET IO (1)	54
Figure 24: Add PROFINET IO (2)	55
Figure 25: Added PROFINET IO Network	55
Figure 26: Added Gateway	56
Figure 27: Set Device Name of Gateway	57
Figure 28: Set IP Address of Gateway	58
Figure 29: Set Further Gateway Parameters (1)	59
Figure 30: Set Further Gateway Parameters (2)	59
Figure 31: Set Diagnostic Address of Gateway	60
Figure 32: Set Application Parameters of Gateway	60
Figure 33: Added SmartWire-DT Slave	62
Figure 34: Configure SmartWire-DT Slave	63
Figure 35: Set Properties of SmartWire-DT Slave	64
Figure 36: Set I/O Addresses of SmartWire-DT slaves, EU5E-SWD-2A2A Example	64
Figure 37: Set Application Parameters for SmartWire-DT Slave, EU5E-SWD-2A2A Example	65
Figure 38: Set PG/PC Interface (1)	67
Figure 39: Set PG/PC Interface (2)	68
Figure 40: Select Target PLC	68
Figure 41: Select Node Address (1)	69
Figure 42: Select Node Address (2)	69
Figure 43: Select Node Address (3)	70
Figure 44: Project Window in SIMATIC Manager	71
Figure 45: Create Data Block	72
Figure 46: Data Block Created	72
Figure 47: Edit Data Block	73
Figure 48: Edit Organization Block	74

Figure 49: Select Blocks Node in SIMATIC Manager	74
Figure 50: Selected CPU in Project Tree	75
Figure 51: Create Variable Table	75
Figure 52: Variable Table Created	76
Figure 53: Edit Variable Table	76
Figure 54: Monitor Input Data	77
Figure 55: Modify Value	78
Figure 56: Add Placeholder	79
Figure 57: Edit Ethernet Node (1)	81
Figure 58: Browse Network	82
Figure 59: Edit Ethernet Node (2)	83
Figure 60: Acyclic Data Address Mapping	84
Figure 61: Acyclic Data Error Detection	85
Figure 62: Diagnosis/Alarms	88
Figure 63: Firmware Update by HTTP (as depicted in Internet Explorer)	91
Figure 64: Reset by HTTP (as depicted in Internet Explorer)	93

11.2 List of Tables

Table 1: List of Revisions	5
Table 2: Reference to Hardware and Firmware	7
Table 3: Reference to Software Tools	7
Table 4: Reference to Drivers	7
Table 5: Reference to Device Description File	7
Table 6: Directory of DVD	8
Table 7: Documentation Overview	11
Table 8: Safety Symbols and Sort of Warning or Principle	19
Table 9: Signal Words	19
Table 10: Description of the LEDs (1)	27
Table 11: Description of the LEDs (2)	28
Table 12: Getting Started	30
Table 13: SWD LED	42
Table 14: APL LED	44
Table 15: Config LED	44
Table 16: Application Parameters of Gateway	61
Table 17: Application Parameters of Slave	66
Table 18: Acyclic Data Error Codes For Read Requests	86
Table 19: Acyclic Data Error Codes For Write Requests	87
Table 20: Diagnosis Parameters	89
Table 21: Diagnosis ChannelErrorType	89
Table 22: Controls in Firmware Update Page	91
Table 23: Technical Data EU5C-SWD-PROFINET Gateway	96
Table 24: Technical Data PROFINET IO Device	97
Table 25: Compatibility of Devices	99

11.3 Contacts

Headquarters

Germany

Hilscher Gesellschaft für
Systemautomation mbH
Rheinstrasse 15
65795 Hattersheim
Phone: +49 (0) 6190 9907-0
Fax: +49 (0) 6190 9907-50
E-Mail: info@hilscher.com

Support

Phone: +49 (0) 6190 9907-99
E-Mail: de.support@hilscher.com

Subsidiaries

China

Hilscher Systemautomation (Shanghai) Co. Ltd.
200010 Shanghai
Phone: +86 (0) 21-6355-5161
E-Mail: info@hilscher.cn

Support

Phone: +86 (0) 21-6355-5161
E-Mail: cn.support@hilscher.com

France

Hilscher France S.a.r.l.
69500 Bron
Phone: +33 (0) 4 72 37 98 40
E-Mail: info@hilscher.fr

Support

Phone: +33 (0) 4 72 37 98 40
E-Mail: fr.support@hilscher.com

India

Hilscher India Pvt. Ltd.
New Delhi - 110 065
Phone: +91 11 43055431
E-Mail: info@hilscher.in

Italy

Hilscher Italia S.r.l.
20090 Vimodrone (MI)
Phone: +39 02 25007068
E-Mail: info@hilscher.it

Support

Phone: +39 02 25007068
E-Mail: it.support@hilscher.com

Japan

Hilscher Japan KK
Tokyo, 160-0022
Phone: +81 (0) 3-5362-0521
E-Mail: info@hilscher.jp

Support

Phone: +81 (0) 3-5362-0521
E-Mail: jp.support@hilscher.com

Korea

Hilscher Korea Inc.
Suwon, Gyeonggi, 443-734
Phone: +82 (0) 31-695-5515
E-Mail: info@hilscher.kr

Switzerland

Hilscher Swiss GmbH
4500 Solothurn
Phone: +41 (0) 32 623 6633
E-Mail: info@hilscher.ch

Support

Phone: +49 (0) 6190 9907-99
E-Mail: ch.support@hilscher.com

USA

Hilscher North America, Inc.
Lisle, IL 60532
Phone: +1 630-505-5301
E-Mail: info@hilscher.us

Support

Phone: +1 630-505-5301
E-Mail: us.support@hilscher.com