

Mains Wiring Configuration Options of the S811+ Reduced Voltage Soft Starter

Application

The S811+ soft starter may be utilized to accomplish motor starting using the Inline or Inside-the-Delta mains wiring configurations. The (0) Inline Wiring or (1) Inside Delta configuration option is selected in the Motor Wiring Configuration parameter located in the Soft Start Configuration Menu. The Inline Wiring configuration is the parameter default from the factory. The Inline Wiring method is the simplest form of connection and may utilize 3-lead, 6-lead, or 12-lead motors. The Inside-the-Delta configuration requires a 6-lead, or 12-lead motor. 3-lead and 9-lead motors cannot be used with the Inside-the-Delta configuration. 24Vdc control command wiring for the S811+ does not change depending on which configuration is used with the load.

Overview

Soft starter mains wiring is shown in Figures 1 & 2 below. The Inline Wiring configuration may be used on motors that are wired in either the Star (Wye) or Delta configuration. Please note that a soft starter (Inline Wiring) / motor (Delta configuration) combination wired in an Inline configuration is not the same as a soft starter (Inside Delta) / motor (Inside-the-Delta) combination wired in an Inside-the-Delta configuration. Inline Wiring applications are often configured with a motor (Delta) combination to achieve maximum torque/horsepower.

More information is provided in the S811+ Inline Wiring Configuration and S811+ Inside-the-Delta Wiring Configuration sections of this document.

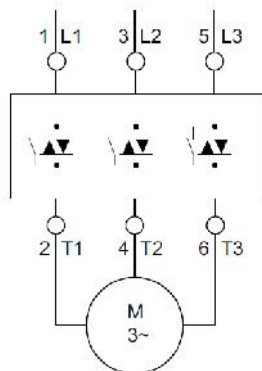

Figure 1 – Inline Configuration

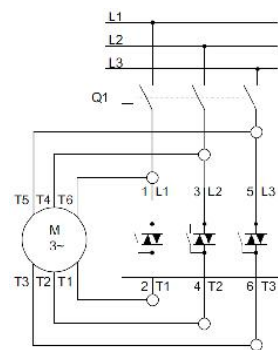

Figure 2 – Inside-the-Delta Configuration

S811+ inline wiring configuration

The catalog tables for the S811+ are based on an inrush value of 300% to 450% motor Full Load Amps (FLA) of the motor. On motors with quadratic loads, starting current rise values are generally 300% to 350% motor nameplate FLA. While start ramp times also must be considered during product selection, the impact of long Soft Start Time values on current rise is minimal. The Initial Torque parameter has the greatest impact on the current rise (Initial Torque/motor circuit impedance) during the start ramp time and may significantly impact the maximum allowable current capacity (soft starter size) due to heat exposure of the SCR's.

NOTE: In the event that the soft starter/motor combination is wired in an Inline Wiring configuration, but the Motor Wiring Configuration parameter is set to inside-the-delta, the start ramp characteristics will be significantly affected. With the soft starter in this situation, a Start command will result in full SCR gating AND internal bypass closure after an approximately 10 second delay after the Start command is received.

CAUTION: If the Start command is a momentary signal, the approximate 10 second delay profile will still be in effect if the soft starter has recognized the Start command. This condition could result in an unexpected motor start due to the failure of the soft starter to energize the motor in the expected time frame and has been interpreted as the unit's "failure" to recognize the Start command. Attempts to correct this condition by reducing the Initial Torque parameter value and/or extending the Soft Start Time will not be effective.

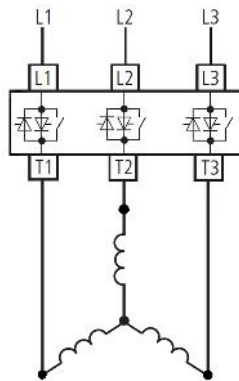

Figure 3 – Star (Wye) Configuration

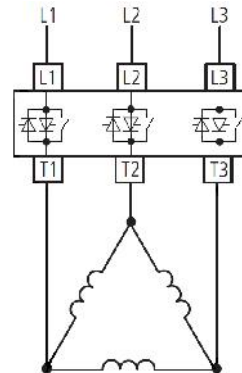

Figure 4 – Delta Configuration

Inline wiring motor circuit protection

A shunt trip breaker may be installed and configured to open in the event that a Fault Trip occurs to provide additional motor protection.

An isolation contactor may be installed in the line side of the soft starter and configured to close 100ms (minimum) prior to the soft starter energization and open with Stop command (or end of Soft Stop time) to provide leakage voltage (SCR) isolation at the motor. Leakage voltage is a normal condition of solid state control devices such as SCR's.

Isolation contactors may be installed in line and load circuits to achieve isolation from alternate motor control devices such as direct-on-line starters or variable frequency drives.

S811+ inside-the-delta wiring configuration

The catalog tables for the S811+ are based on an inrush value of 300% to 450% FLA of the motor, similar to an Inline Wiring configuration. The main characteristic of an Inside Delta configuration is the reduction in current by a factor of $\sqrt{3}$ that the soft starter is exposed to for the same size motor when compared to an Inline Wiring configuration. To accomplish an Inside Delta wiring configuration, the motor must be either a 6-lead or 12-lead motor. 3-lead and 9-lead motors cannot be configured for Inside-the-Delta operation.

NOTE: In the event that the soft starter/motor combination is wired in an Inside-the-Delta configuration, but the Motor Wiring Configuration parameter is still set to Inline Wiring (default), the start ramp characteristics will be significantly affected. With the soft starter in this situation, a Start command will result in full SCR gating. Closure of the internal bypass contactors will occur when the motor achieves synchronous speed. Attempts to reduce the aggressiveness of this start profile by reducing the Initial Torque values and/or extending the Soft Start Time ramp will not be effective.

CAUTION: Please note that mains mis-wiring and/or improper selection of the Motor Wiring Configuration parameter is not monitored by any protection parameter.

The overload protection threshold values based on Motor FLA values do not need to be calculated for the S811+. When the Inside Delta configuration is selected, the Motor Nameplate FLA values shift to line current (motor nameplate) values.

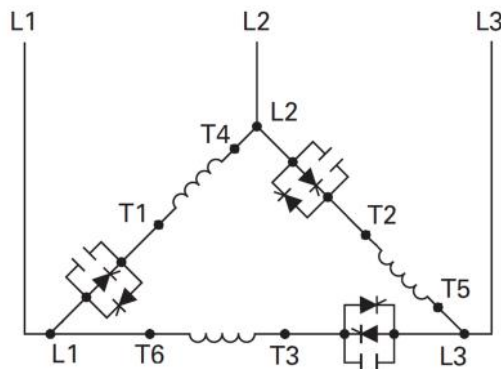

Figure 5 – Inside-the-Delta Configuration

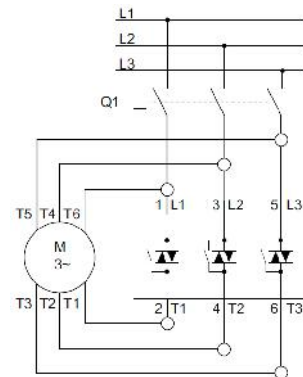

Figure 6 – Circuit Protection

Inside-the-delta motor circuit protection:

NOTE: Installation of an isolation contactor or shunt trip breaker in an Inside-the-Delta configuration is highly recommended. In Figure 5 for example, a single phase condition will be created between L1 and L2 if Phase A (L1-T1) becomes shorted for any reason. Due to the circuit impedance which includes the motor winding (T1-T4), current flow in most applications will not be high enough to cause a breaker to open (overload trip) before the motor winding becomes damaged from overheating.

The S811+ can be configured to open a shunt trip breaker in the event of any Fault Trip or up to three (3) dedicated Fault Trip conditions to provide additional motor protection.

Figure 6 shows an isolation contactor Q1 (or shunt trip breaker) on the line side of the soft starter.

The S811+ and the isolation contactor may be controlled simultaneously with the soft starter from a single RUN command by adjusting the Start Delay parameter found in the Advanced I/O Setup Menu to allow the isolation contactor to close completely 100ms (minimum) before the S811+ begins the Start cycle. The isolation contactor may be configured to open when the S811+ receives a Stop command, or at the end of the Soft Stop time. This configuration will also provide leakage voltage (SCR) isolation at the motor. Leakage voltage is a normal condition of solid state control devices such as SCR's.

The use of isolation contactors staged by the Run Command provides the benefit of soft starter/motor isolation at all times when the application is not running, and regardless of the operational status of the soft starter.

Isolation contactors may be installed in line and load circuits to achieve isolation from alternate motor control devices such as direct-on-line starters or variable frequency drives.

Additional Help

In the US or Canada: please contact the Technical Resource Center at 1-877-ETN-CARE or 1-877-326-2273 option 2, option 2.

All other supporting documentation is located on the Eaton web site at www.eaton.com/softstaters



Eaton
1000 Eaton Boulevard
Cleveland, OH 44122 USA
Eaton.com

© 2014 Eaton
All Rights Reserved
Printed in USA
Publication No. AP039009EN
December 2014

Eaton is a registered trademark
of Eaton Corporation.

All other trademarks are property
of their respective owners