

## D65VMLS Series Voltage Monitoring Relay Product Installation Leaflet

### THE MONITOR

The D65VMLS Voltage Monitoring Relay is a protective device for three-phase, Wye or Delta connected, power distribution networks supplying motor circuits. It may be installed in a motor feeder and control the supply to a number of motors or in a motor branch circuit to protect a single motor and its load. The D65VMLS automatically operates when one or more phases of the three-phase supply is lost, or when the phase sequence is reversed.

Each D65VMLS also responds to overcharge conditions (+10% fixed), a pre-selected under voltage threshold, and a pre-selected percent of phase imbalance. The percent phase imbalance is adjustable from 2-10% and the under voltage dropout can be set at 80-95% of the operating voltage. The adjustable time delay dropout on under voltage (0.3-30 seconds) eliminates nuisance tripping caused by momentary voltage fluctuations. There is also an adjustable time delay (1-300 seconds) on both power up and on restart after a fault has been cleared.

### INSTALLATION

This industrial type control is designed to be installed, operated, maintained by adequately trained workers. These instructions do not cover all details, variations, or combinations of the equipment, its storage, delivery, installation, check out, safe operation, or maintenance. Care must be exercised to comply with local, state, and national regulations, as well as safety practices, for this class of equipment.

### MOUNTING AND WIRING

See Figure 1. The D65VMLS can be mounted directly on 35mm DIN track.

Figure 2 shows the wiring diagram. When the proper three-phase line voltage is applied to the unit and the phase sequence is correct, the relay is energized after the Restart Delay is completed. The N.C. contacts across terminals 7 & 8 and 11 & 12 open, and the N.O. contacts across terminals 8 & 9 and 10 & 11 open. Any one of five fault conditions will de-energize the relay after a delay and the contacts return to their normal state.

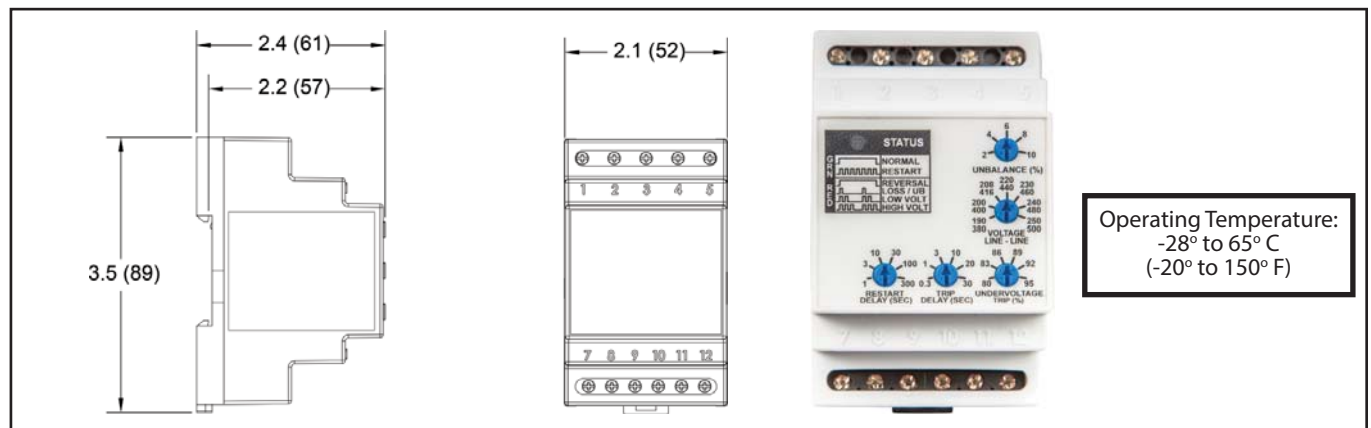

Operating Temperature:  
-28° to 65° C  
(-20° to 150° F)

Fig. 1 Dimension Drawing: Inches (mm)

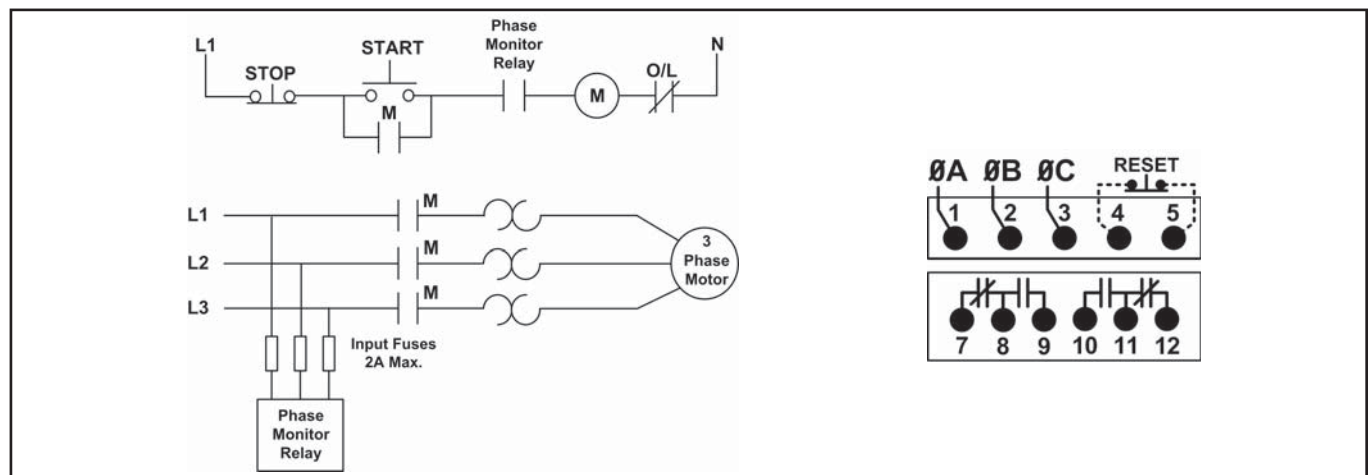

Fig. 2 Wiring Diagram

# INSTRUCTIONS AND OPERATION IL121002EN

Effective June 2017

## INSTALLATION AND SETUP

- Mount the relay on 35mm DIN rail in a suitable enclosure. Use one #12-30 solid or stranded copper or copper-clad aluminum conductors- a terminal tightening torque of 7in-lbs should be used.
- Set the VOLTAGE LINE-LINE knob to the actual three-phase line-to-line voltage. The Voltage Line-Line knob on the D65VMLS480 has two ranges (see Figure 1 on reverse side): 190-250V on the low voltage scale and 380-500V on the high voltage scale. The unit auto senses the three-phase line-line voltage when applied and automatically selects one of the two ranges. The D65VMLS120 has a single adjustable range of 102-138V and the D65VMLS600 has a single adjustable range of 460-600V.
- Set initial settings on the UNDERVOLTAGE TRIP, TRIP DELAY and RESTART DELAY knobs to minimum. Set initial setting on the UNBALANCE knob to maximum.
- Connect the three-phase line-line voltage to terminals 1, 2 and 3 (see Wiring Diagram on the side of the relay or Figure 2 on reverse side). A connection to the neutral or ground is not required in Wye systems. DO NOT connect output wires to terminals 7-12 until later (Step 12).
- RESET: As standard, the D65VMLS Series relays are in the Automatic Reset mode, which means they will automatically reset once the fault has been corrected. However, they can be set up in the Manual Reset mode by connecting an external N.C. switch across terminals 4 and 5. Upon application of three-phase voltage, the D65VMLS Series will go into Manual Reset mode if it recognizes a closure across terminals 4 and 5. After a fault clears, the relay will not reset until the N.C. switch is opened. NOTE: this unit can only be set back to Automatic Reset mode from Manual Reset mode by removing three-phase voltage, re moving the N.C. switch across terminals 4 and 5, and reapplying the three-phase voltage.
- Apply three-phase voltage. The LED indicator should initially flash GREEN if in the Automatic Reset mode while the relay goes through its start-up delay or waiting for an external switch to be operated if in the Manual Reset mode and then illuminate solid GREEN. If the LED turns RED solid or flashing, a fault condition exists and must be corrected. Use the LED Status Table at right to determine exact cause of fault. Make required corrections.

## SETTINGS

- REMOVE THREE-PHASE VOLTAGE for Steps 8-12.
- Set the RESTART DELAY knob. This setting should be the time period required after a fault has been cleared before the relay should automatically energize. NOTE: this value is ignored when in the Manual Reset mode (see Step 5).
- Set the UNDERVOLTAGE TRIP knob between 80 and 95% of the line-line voltage setting. This value should be the same as the minimum operating voltage for the equipment to be adequately protected.
- Set the TRIP DELAY knob. This is the maximum time period that an unbalance, undervoltage or overvoltage condition should be allowed to last. Too short a setting will cause nuisance tripping if there are momentary changes in the three-phase voltage. Too long a setting could cause damage to the equipment. Note that the setting should be at least slightly longer than the time a three-phase motor is drawing its inrush or startup current. This will avoid nuisance tripping caused by the starting current.

Eaton Corporation  
Electrical Group  
1000 Cherrington Parkway  
Moon Township, PA 15108  
United States  
877-ETN-CARE (877-386-2273)  
www.Eaton.com

© 2010 Eaton Corporation  
All Rights Reserved  
Printed in USA  
Publication No. P49991/ 004  
December 2010



# Instructions for D65VMLS Series Voltage Monitoring Relay

- Set the UNBALANCE knob. This setting should be the maximum allowable unbalance in phase voltage that the three-phase system can tolerate. Too low of a setting can cause nuisance tripping. Too high of a setting may not adequately protect the system.

## OPERATION

- Connect the output terminal wires to terminals 7-12 (see Wiring Diagram on the side of the relay or Figure 2 on reverse side).
- When all connections are made, apply three-phase line-line voltage. The LED indicator should initially flash GREEN while the relay goes through its restart delay or waiting for an external switch to be operated if in the Manual Reset mode and then illuminate solid GREEN when all voltage conditions are correct.
- If the LED does not illuminate solid GREEN during regular operation, a fault condition has occurred. REMOVE THREE-PHASE VOLTAGE, and check for proper phase rotation, presence of all three phases, and low or high voltage conditions. Use the LED Status Table or the Troubleshooting Guide below to determine exact cause of fault. Correct if necessary. Re-energization is automatic upon correction of the fault condition unless using MANUAL RESET, which requires opening

LED STATUS TABLE		
NORMAL		NORMAL (RELAY ON)
		RESTART (DELAY)
FAULT		REVERSAL
		LOSS/UB (UNBALANCE)
		LOW VOLT (UNDERVOLTAGE)
		HIGH VOLT (OVERVOLTAGE)

Table I - RELAY OUTPUT
10A @ 277V AC / 30V DC 1/2 hp @ 120 / 240V AC (N.O.) 1/3 hp @ 120 / 240V AC (N.C.) B300 Pilot Duty, R300 (N.O.)

Table II - REPLACEMENT UNITS		
Mounting	Nominal Voltage	Catalog Number
DIN Rail	102-138	D65VMLS120C
	190-500	D65VMLS480C
	460-600	D65VMLS600C

Table III - RECOMMENDED SPECS	
Wire Range	Torque, Plug-In Unit
(1) #12 to 30	7 LB-IN

\* Use conductors rated for 75°C or better when use temperatures exceeding 60°C.  
TROUBLESHOOTING GUIDE

If the unit fails to operate, check connections per Figure 2. For assistance, call EATON Resource Center (TCR) at 1-800-809-2772.



PowerChain Management®

PowerChain Management is a registered trademark of Eaton Corporation.

All other trademarks are property of their respective owners.