

**Motor Protection Circuit Breaker**



**Manual Motor Protector**



**Overload Relay—C440**



**Overload Relays—C441 Motor Insight**



**Motor Management Relay—  
Power Xpert C445**



## 5.1 Monitoring Relays

Product Overview—Monitoring Relays .....	V5-T5-2
Current Monitoring Relays .....	V5-T5-3
Phase Monitoring Relays .....	V5-T5-5
Voltage Monitoring Relays .....	V5-T5-13
Ground Fault Monitoring Relays .....	V5-T5-24

## 5.2 Motor Protection Circuit Breakers

Motor Protection Circuit Breakers (MPCB) .....	V5-T5-37
--	----------

## 5.3 Manual Motor Protection

Manual Motor Protectors—XTPB, XTPR and XTPE .....	V5-T5-38
---	----------

## 5.4 Overload Relays

Product Overview .....	V5-T5-40
<b>XT</b> IEC Overload Relays .....	V5-T5-42
C306 Bimetallic Overload Relays .....	V5-T5-46
C440/ <b>XT</b> Electronic Overload Relay .....	V5-T5-47
C441 Overload Relays .....	V5-T5-68
C445 Motor Management Relay .....	V5-T5-90

## Volume 5—Motor Control and Protection, CA08100006E

### Tab 5—Motor Protection and Monitoring

Revision date	Section	Change page(s)	Description
07/11/2019	—	All	Update TOC
07/11/2019	5.4	V5-T5-90 to end	Content edits and new content additions



*Powering Business Worldwide*

#### Monitoring Relays



5

#### Contents

##### Description

##### Page

Monitoring Relays	
Current Monitoring Relays	V5-T5-3
Phase Monitoring Relays	V5-T5-5
Voltage Monitoring Relays	V5-T5-13
Ground Fault Monitoring Relays	V5-T5-24

### Product Overview—Monitoring Relays

#### Current Monitoring Relays

The CurrentWatch ECS and ECSJ Series from Eaton's Electrical Sector is a family of solid-state adjustable current switches, ideal for providing status information on electrical equipment.

#### Phase Monitoring Relays

The D65 Series Phase Monitoring Relays provide protection against premature equipment failure caused by voltage faults on three-phase systems. All D65 phase monitoring relays are compatible with most wye or delta systems. In wye systems, a connection to neutral is not required. Phase Monitoring relays protect against single-phasing regardless of any regenerative voltages.

#### Voltage Monitoring Relays

The D65 Series Voltage Monitoring Relays monitor either AC single-phase (50/60 Hz) or DC voltages to protect equipment against voltage fault conditions. No separate supply (input) voltage is required. All versions are available in a compact plug-in case using an 8-pin octal socket.

There are two styles of voltage monitoring relays:

- Over/Undervoltage Relays
- Voltage Band Relays

#### Ground Fault Monitoring Relays

Eaton offers two different series of ground fault monitoring relays:

##### D64R Series

- The D64R digital ground fault relays are microprocessor-based and replace the previous generation of analog-based devices
- Microprocessor-based D64R GFRs combine more selectable features into a single model, which makes easier model selection and reduces spares inventory requirements

##### D64L Series

- Type D64L ground fault monitors are designed to monitor ungrounded supplies on three-phase AC power systems up to 600 V. If an insulation fault develops anywhere on the system between the source and the load, the D64L will detect it and give an alarm or trip, depending on the adjustable field settings selected
- The D64L is ideally suited for systems supplied from the secondary of either an ungrounded delta or an ungrounded wye connected transformer

**ECS Series CurrentWatch Current Switches**



**Contents**

<i>Description</i>	<i>Page</i>
Current Monitoring Relays	
ECS Series CurrentWatch Current Switches	
ECSJ Series CurrentWatch Current Switches . . .	<b>V5-T5-4</b>
Phase Monitoring Relays . . . . .	<b>V5-T5-5</b>
Voltage Monitoring Relays . . . . .	<b>V5-T5-13</b>
Ground Fault Monitoring Relays . . . . .	<b>V5-T5-24</b>

**ECS Series CurrentWatch™ Current Switches**

**ECS Series**

**Product Description**

The CurrentWatch™ ECS Series from Eaton’s Electrical Sector is a family of solid-state adjustable current switches, ideal for providing status information on electrical equipment. The ECS is excellent for new installations, where the conductors run through the housing, requiring no cutting. These switches are also ideal for retrofits, since split-core models can be opened to fit around existing conductors. The current switch is accurate, reliable and easy to install.

The ECS can sense continuous currents from 1 to 150 A and does not require any supply voltage, as the power required is induced from the monitored conductor. The output is a non-polarity-sensitive solid-state contact for switching AC and DC circuits up to 240 Vac/Vdc. This switch also includes an LED indicating two states: on and below trip point, and above trip point with contacts energized. All ECS Series switches carry an unconditional five-year warranty.

Any change in current can be sensed with the ECS Series. A change in current may indicate motor failure, belt loss/slippage or mechanical failure. Any of these events can cause the current to drop significantly, tripping the switch and notifying the controller.

**Standards and Certifications**

- UL® Listed
- cUL® Listed
- CE Certified



**Reference**

Refer to **Volume 8—Sensing Solutions**, CA08100010E, Tab 7, section 7.2 for additional product information.

<b>ECS Series CurrentWatch</b>	<b>Tab Section</b>
Application Description . . . . .	<b>7.2</b>
Product Selection . . . . .	<b>7.2</b>
Accessories . . . . .	<b>7.2</b>
Technical Data and Specifications . . . . .	<b>7.2</b>
Wiring Diagrams . . . . .	<b>7.2</b>
Dimensions . . . . .	<b>7.2</b>

#### ECSJ Series CurrentWatch Current Switches



5

#### Contents

##### Description

	<i>Page</i>
Current Monitoring Relays	
ECS Series CurrentWatch Current Switches . . .	<b>V5-T5-3</b>
ECSJ Series CurrentWatch Current Switches	
Phase Monitoring Relays . . . . .	<b>V5-T5-5</b>
Voltage Monitoring Relays . . . . .	<b>V5-T5-13</b>
Ground Fault Monitoring Relays . . . . .	<b>V5-T5-24</b>

#### ECSJ Series CurrentWatch Current Switches

##### ECSJ Series

##### Product Description

The CurrentWatch™ ECSJ Series current operated switches from Eaton’s Electrical Sector provide the same dependable indication of status offered by the CurrentWatch ECS Series, but with the added benefit of increased setpoint precision. A choice of three, jumper-selectable input ranges allows the ECSJ Series to be

tailored to an application, providing more precise control through improved setpoint resolution. Self-powering, isolated solid-state outputs, 1–6 A, 6–40 A and 40–200 A input ranges, and a choice of split- or solid-core enclosures are standard. For typical applications of the CurrentWatch ECSJ Series, see listing on this page.

##### Application Description

- Typical Applications
- **Electronic Proof of Flow**—Current operated switches eliminate the need for multiple pipe or duct penetrations and are more reliable than electro-mechanical pressure or flow switches
  - **Conveyors**—Detect jams and overloads
  - **Lighting Circuits**—Easier to install and more accurate than photocells
  - **Fans, Pumps and Heating Elements**—Faster response than temperature sensors
  - **Critical Motors**
  - **Ancillary Equipment**

##### Standards and Certifications

- UL Listed
- cUL Listed
- CE Certified
- UL 508 Industrial Equipment (USA and Canada)



##### Reference

Refer to **Volume 8—Sensing Solutions**, CA08100010E, Tab 7, section 7.3 for additional product information.

<i>ECSJ Series CurrentWatch</i>	<i>Tab Section</i>
Application Description . . . . .	<b>7.3</b>
Product Selection . . . . .	<b>7.3</b>
Accessories . . . . .	<b>7.3</b>
Technical Data and Specifications . . . . .	<b>7.3</b>
Wiring Diagrams . . . . .	<b>7.3</b>
Dimensions . . . . .	<b>7.3</b>

### Phase Monitoring Relays



### Product Overview

The D65 Series Phase Monitoring Relays provide protection against premature equipment failure caused by voltage faults on three-phase systems. All D65 phase monitoring relays are compatible with most wye or delta systems. In wye systems, a connection to neutral is not required. Phase Monitoring relays protect against single-phasing regardless of any regenerative voltages.

### Application Description

#### Protection

Depending on the unit selected, it will protect three-phase equipment against:

- **Phase Loss**—total loss of one or more of the three phases. Also known as “single phasing.” Typically caused by a blown fuse, broken wire or worn contact. This condition would result in a motor drawing locked rotor current during startup. In addition, a three-phase motor will continue to run after losing a phase, resulting in possible motor burn-out.
- **Phase Reversal**—reversing any two of the three phases will cause a three-phase motor to run in the opposite direction. This may cause damage to driven machinery or injury to personnel. The condition usually occurs as a result of mistakes made during routine maintenance or when modifications are made to the circuit.
- **Phase Imbalance**—imbalance of a three-phase system occurs when single-phase loads are connected such that one or two of the lines (phases) carry more or less of the load. This could cause motors to run at temperatures above published ratings.
- **Undervoltage**—when voltage in all three lines of a three-phase system drop simultaneously.
- **Overvoltage**—when voltage in all three lines of a three-phase system increase simultaneously.

### Contents

<b>Description</b>	<b>Page</b>
Current Monitoring Relays . . . . .	V5-T5-3
Phase Monitoring Relays	
Product Selection Guide . . . . .	V5-T5-6
D65PLR Series—Phase Loss and Reversal . . . . .	V5-T5-7
D65VM Series—Phase Loss, Reversal, Imbalance and Under/Overvoltage . . . . .	V5-T5-9
Voltage Monitoring Relays . . . . .	V5-T5-13
Ground Fault Monitoring Relays . . . . .	V5-T5-24

#### Device Connection

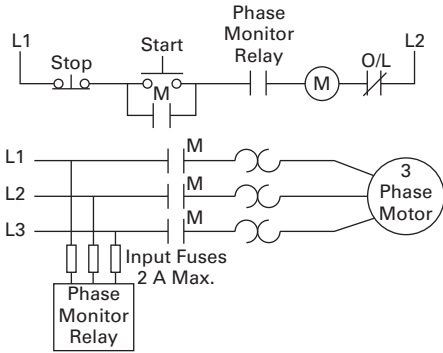

#### Standards and Certifications

##### D65PLR Series

- cRUus listed
- RoHS recognized
- CE marked



##### D65VMLP Series

- cRUus listed
- RoHS recognized
- CE marked



##### D65VMLS Series

- cULus listed
- RoHS recognized
- CE marked



#### Product Selection Guide

##### D65 Series—Product Family Selection

Series	Mounting Style	Phase Reversal	Phase Loss and Reversal	Undervoltage	Overvoltage	Phase Imbalance	Time Delay on Undervoltage
D65PLR	Plug-in <sup>①</sup>	3	3	—	—	—	—
D65VMLP	Plug-in <sup>①</sup>	3	3	✓ (adjustable)	✓ (fixed)	3	0.1–20 sec
D65VMLS	Surface	3	3	✓ (adjustable)	✓ (fixed)	3	0.1–20 sec

##### Note

<sup>①</sup> In addition to the above approvals, all plug-in products are also UL Listed when used with the appropriate Eaton socket.

### D65PLR Series—Phase Loss and Reversal



### D65PLR Series—Phase Loss and Reversal

#### Product Description

The D65PLR Series Monitoring Relays provide protection against phase loss and phase reversal in a compact plug-in design. These devices are designed to be compatible with most wye or delta systems. In wye systems, a connection to a neutral is not required. Phase monitoring relays protect against single-phasing regardless of any regenerative voltages.

A bi-color LED indicates NORMAL conditions with a green status, PHASE REVERSAL conditions with a steady red status, and PHASE LOSS conditions with a flashing red status. Re-energization is automatic upon correction of the fault condition.

#### Features

- Protects against phase loss and phase reversal
- True RMS voltage sensing for improved accuracy
- Continued operation through phase loss conditions
- Bi-color LED provides indication for both normal and fault conditions
- Compact plug-in case utilizing industry-standard 8-pin octal socket
- 10 A SPDT output contacts

### Contents

#### Description

	<i>Page</i>
Current Monitoring Relays . . . . .	V5-T5-3
Phase Monitoring Relays	
Product Selection Guide . . . . .	V5-T5-6
D65PLR Series—Phase Loss and Reversal	
Product Selection . . . . .	V5-T5-8
Technical Data and Specifications . . . . .	V5-T5-8
Dimensions . . . . .	V5-T5-8
D65VM Series—Phase Loss, Reversal, Imbalance and Under/Overvoltage . . . . .	V5-T5-9
Voltage Monitoring Relays . . . . .	V5-T5-13
Ground Fault Monitoring Relays . . . . .	V5-T5-24

#### Standards and Certifications

- cRUus
- UL listed ①
- RoHS compliant



#### Note

① When used with appropriate Eaton socket.



#### Product Selection

D65PLR480



#### D65PLR Series, Phase Loss and Reversal

Mounting Style	Nominal Voltage	Catalog Number
Plug-in	190–500 V	D65PLR480 ①

#### Accessories

#### D65PLR Series, Phase Loss and Reversal

Description	Standard Pack	Catalog Number
8-pin socket	10	D3PA2
Hold-down spring	10	D65CHDS

#### Technical Data and Specifications

#### D65PLR Series, Phase Loss and Reversal

Description	Specification
Phase loss	Unit trips on loss of any Phase A, B or C
Phase reversal	Unit trips if sequence of the three phases is anything other than A-B-C
Output contacts	10 A SPDT at 277 Vac, 1 hp at 250 Vac, 1/2 hp at 120 Vac. C300 pilot duty
Life	Full load—100,000 operations
Response times	
Operate	50 ms
Release	50 ms
Load (burden)	3 VA
Temperature	–20 to 150 °F (–28 to 65 °C)
Transient protection	10,000 volts for 20 microseconds
Mounting	Uses an 8-pin octal socket. Requires a 600 V rated socket when used on system voltages greater than 300 V
Indicator LED	Bi-color LED will be Green when NORMAL condition is present, Steady Red when PHASE REVERSAL condition is present, and Flashing Red when PHASE LOSS condition is present
Reset	Automatic upon correction of fault

#### Wiring Diagram

#### Wiring for 8-Pin Socket

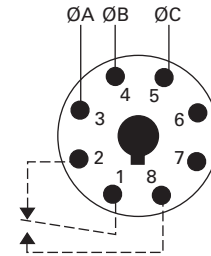

#### Dimensions

Approximate Dimensions in Inches (mm)

#### D65PLR Series, Phase Loss and Reversal

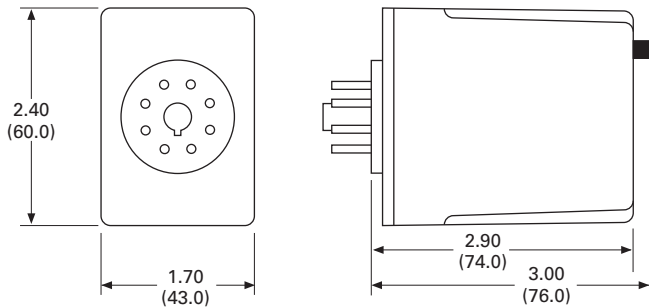

#### Note

① Requires a 600 V rated socket when used on system voltages greater than 300 V.

**D65VM Series—Phase Loss, Reversal, Imbalance and Under/Overtoltage**



**Contents**

<i>Description</i>	<i>Page</i>
Current Monitoring Relays . . . . .	<b>V5-T5-3</b>
Phase Monitoring Relays	
Product Selection Guide . . . . .	<b>V5-T5-6</b>
D65PLR Series—Phase Loss and Reversal . . . . .	<b>V5-T5-7</b>
D65VM Series—Phase Loss, Reversal, Imbalance and Under/Overtoltage	
Features . . . . .	<b>V5-T5-10</b>
Product Selection . . . . .	<b>V5-T5-11</b>
Technical Data and Specifications . . . . .	<b>V5-T5-11</b>
Dimensions . . . . .	<b>V5-T5-12</b>
Voltage Monitoring Relays . . . . .	<b>V5-T5-13</b>
Ground Fault Monitoring Relays . . . . .	<b>V5-T5-24</b>

**D65VM Series—Phase Loss, Reversal, Imbalance and Under/Overtoltage**

**Product Description**

Eaton’s D65 Phase Monitoring Relay protects distribution systems supplying motor feeder or branch circuits against premature equipment failure caused by voltage faults on three-phase systems—wye or delta connected. Phase monitoring relays protect against voltage imbalance and single-phasing regardless of any regenerative voltages. The relay is energized when the phase sequence and all voltages are correct. Any of five abnormal conditions (phase loss, phase reversal, overvoltage, undervoltage or phase imbalance) will de-energize the relay. As standard, re-energization is automatic upon correction of the fault condition. The D65 can also be wired for manual reset.

**Application Description**

**Protective Functions**

The D65 Series Relay makes separate trip decisions based on the status of the three-phase voltage inputs. Control power is derived from the three-phase voltage inputs. Separate control power is not required. The device will trip in response to any combination of the following conditions:

- **Undervoltage**—When voltage in all three lines of a three-phase system drops simultaneously. Undervoltage drop-out can be set at 80–95% of operating voltage. Unit trips when the average of all three lines is less than the adjusted set point for a period longer than the adjustable time delay drop-out (0.1–20 seconds). This time delay eliminates nuisance tripping caused by momentary voltage fluctuation.

- **Overtoltage**—Fixed at 110% of nominal, unit trips when the average of all three lines is greater than the fixed set point for a period longer than the time delay drop-out.
- **Phase Imbalance**—Imbalance of a three-phase system occurs when single-phase loads are connected such that one or two of the lines (phases) carry more or less of the load. This could cause motors to run at temperatures above published ratings. Unit trips when any one of the three lines is more than the adjusted set point below the average of all three lines. The percent phase imbalance is adjustable from 2–10% and also has a Disable setting for applications where poor voltage conditions could cause nuisance tripping.
- **Phase Loss (Single-Phasing)**—Total loss of one or more of the three phases. Typically caused by a blown fuse, broken wire or worn contact. This condition would result in a motor drawing locked rotor current during start-up. In addition, a three-phase motor will continue to run after losing a phase, resulting in potential motor burn-out. Unit trips on loss of any phase.
- **Phase Reversal**—Reversing any two of the three phases will cause a three-phase motor to run in the opposite direction. This may cause damage to machinery or injury to personnel. Unit trips if rotation (sequence) of the three phases is anything other than A-B-C.

#### Device Connection

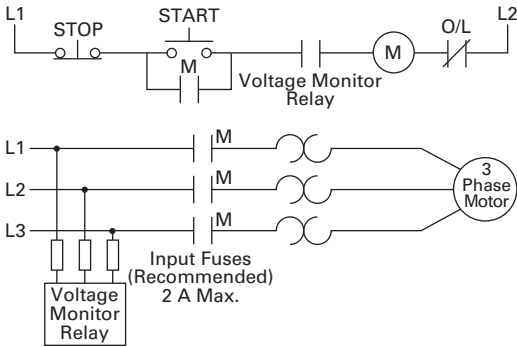

5

#### Features

- Universal voltage range of 190–500 V provides the flexibility to cover a variety of applications (120 V and 600 V units also available)
- True RMS voltage sensing for improved accuracy
- Continued operation through phase loss conditions
- Automatic or manual reset after the fault condition is corrected
- Bi-color LED indicates normal condition and defines fault type for simpler troubleshooting
- D65VMLS can be mounted directly onto 35 mm DIN rail with no additional parts
- D65VMLP will plug into D3PA2 socket and mount on 35 mm DIN rail
- Small, compact size
- User-adjustable settings include nominal voltage, percent phase imbalance, undervoltage drop-out, time delay on undervoltage and time delay on restart after fault

#### Operation

The D65 provides protection against premature equipment failure caused by voltage faults on three-phase systems. The D65 is designed to be compatible with most wye or delta systems. In wye systems, a connection to a neutral is not required. D65 Phase Monitoring Relays protect against imbalanced voltages or single-phasing regardless of any regenerative voltages.

The relay is energized when the phase sequence and all voltages are correct. Any one of five fault conditions will de-energize the relay. Re-energization is automatic upon correction of the fault condition.

Manual reset is available if a NC switch is wired to the appropriate terminals. A bi-color LED indicates normal condition and also provides

specific fault indication to simplify troubleshooting. The percent phase imbalance is adjustable from 2–10%, and the undervoltage drop-out can be set at 80–95% of operating voltage. The adjustable time delay drop-out on undervoltage (0.3–30 sec) eliminates nuisance tripping caused by momentary voltage fluctuations.

#### LED Operation

LED Status	Plug-In and Surface-Mount Indication
Green steady	Normal/relay ON
Green flashing	Power-up/restart delay
Red steady	Reversal
Red single flash <sup>①</sup>	Loss/imbalance
Red double flash <sup>②</sup>	Undervoltage
Red triple flash <sup>③</sup>	Overvoltage

#### Notes

- <sup>①</sup> Single flash = On 25 ms, Off 175 ms.
- <sup>②</sup> Double flash = On 25 ms, Off 25 ms, On 25 ms, Off 125 ms.
- <sup>③</sup> Triple flash = On 25 ms, Off 25 ms, On 25 ms, Off 25 ms, On 25 ms, Off 75 ms.

### Standards and Certifications

- CE (Low Voltage + EMC Directive EN60947-5-1)
- cULus listed (D65VMLS only)
- cRUus (D65VMPL only)
- RoHS compliant
- UL Listed ①



### Product Selection

#### D65VM



#### D65VM Series—Phase Loss, Reversal, Imbalance and Under/Overvoltage ②

Mounting Style	Operating Voltage 50/60 Hz	Catalog Number
Surface-mount (DIN rail)	102–138 V	<b>D65VMLS120C</b>
	190–500 V	<b>D65VMLS480C</b>
	460–600 V	<b>D65VMLS600C</b>
Plug-in (DIN rail)	102–138 V	<b>D65VMPL120</b>
	190–500 V	<b>D65VMPL480</b> ③
	460–600 V	<b>D65VMPL600</b>
8-pin socket	—	<b>D3PA2</b>
8-pin IP20 rated socket	—	<b>D3PA6</b>

### Technical Data and Specifications

#### D65VM Series—Phase Loss, Reversal, Imbalance and Under/Overvoltage

Description	Specification
Nominal voltages (50–60 Hz)	
For D65VMLS	102–138 V, 190–500 V, 460–600 V
For D65VMPL	102–138 V, 190–500 V, 460–600 V
Connections	Wye or delta
Output contacts	
For D65VMLS	DPDT: NO: 10 A resistive at 277 Vac/30 Vdc, 1/2 hp at 120/240 Vac, B300 pilot duty, R300 NC: 10 A resistive at 277 Vac/30 Vdc, 1/3 hp at 120/240 Vac, B300 pilot duty, R300
For D65VMPL	SPDT: 10 A SPDT at 277 Vac, 1 hp at 250 Vac, 1/2 hp at 120 Vac, C300 pilot duty
Dielectric	1000 V + (2 * nominal voltage rating) between input terminals and case or active circuitry
Operating temp.	–20 to 150 °F (–28 to 65 °C)
Response times	
Power up	1–300 seconds adjustable
Restart after fault	1–300 seconds adjustable
Dropout due to fault	100 ms fixed on phase loss and phase reversal; 0.3–30 sec adjustable for all other faults—unbalance, undervoltage, overvoltage
Mechanical life	10,000,000 operations
Electrical life	100,000 operations
Power consumption	40 VA
Hysteresis	2–3%

#### Notes

- ① When used with accompanying Eaton Socket (D65VMPL only).
- ② Additional models available. Please visit our Web site for the latest offering.
- ③ Requires a 600 V-rated socket when used on system voltages greater than 300 V. The D3PA2 socket is rated 10 A, 600 V.

#### Wiring Diagrams

##### Plug-In

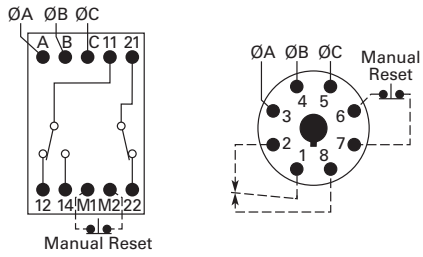

##### Surface-Mount

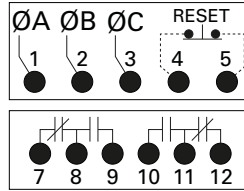

#### Dimensions

Approximate Dimensions in Inches (mm)

##### Plug-In

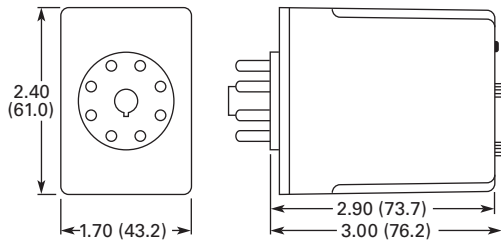

##### Surface-Mount

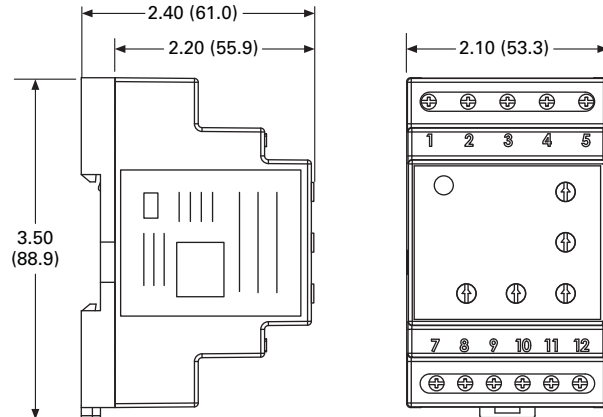

### Voltage Monitoring Relays



### Product Overview

Voltage Monitoring Relays monitor either AC single-phase (50/60 Hz) or DC voltages to protect equipment against voltage fault conditions. No separate supply (input) voltage is required. All versions are available in a compact plug-in case using an 8-pin octal socket.

There are two styles of voltage monitoring relays:

- Over/Undervoltage Relays
- Voltage Band Relays

### Over/Undervoltage Relays

Over/Undervoltage Relays provide protection to equipment where either an over- or undervoltage condition is potentially damaging. Each relay can be used as either an overvoltage or an undervoltage relay, depending on the output contact used. When used as an undervoltage relay, it provides protection to equipment that is required to operate above a minimum voltage. When used as an overvoltage relay, it protects equipment against excessive voltage conditions. Over/undervoltage relays are designed to operate when the operating voltage reaches a preset value and drop out when the operating voltage drops to a level below the preset value.

### Contents

<b>Description</b>	<b>Page</b>
Current Monitoring Relays .....	<b>V5-T5-3</b>
Phase Monitoring Relays .....	<b>V5-T5-5</b>
Voltage Monitoring Relays	
Product Selection Guide .....	<b>V5-T5-14</b>
D65VMRP Over/Undervoltage Relays (Fixed Time Delay) .....	<b>V5-T5-15</b>
D65VAKP Over/Undervoltage Relays .....	<b>V5-T5-18</b>
D65VWKP Voltage Band Relays .....	<b>V5-T5-21</b>
Ground Fault Monitoring Relays .....	<b>V5-T5-24</b>

### Voltage Band Relays

Voltage Band Relays provide protection to equipment that is required to operate within an upper and lower voltage limit. As long as the operating voltage remains within an over- and undervoltage range, the internal relay stays energized. If the operating voltage falls outside this range, the relay will drop out.

### Standards and Certifications

- CE
- cRUus listed
- UL listed ①
- RoHS recognized



**Note**

① When used with accompanying Eaton socket.

## Product Selection Guide

### D65V Product Family Selection—Over/Undervoltage Relays

Series	Pickup Voltage	Dropout Voltage	Time Delay Dropout	Fixed Time Delay for Over/Undervoltage Relays	Adjustable Time Delay Over/Undervoltage Relays
D65VMRP	Adjustable 75–125% nominal	Fixed at 95% of pickup	Fixed 500 ms <sup>①</sup>	<b>Page V5-T5-16</b>	—
D65VAKP		Adjustable 75–95% of pickup	Adjustable 0.1–10 seconds	—	<b>Page V5-T5-19</b>

5

### D65V Product Family Selection—Voltage Band Relays

Series	Pickup Voltage	Dropout Voltage	Time Delay Dropout	Voltage Band Relays
D65VWKP	Adjustable 75–125% nominal	Adjustable 75–95% of pickup	Adjustable 0.1–10 seconds	<b>Page V5-T5-22</b>

#### Note

<sup>①</sup> Fixed time delay eliminates nuisance tripping due to short voltage surges or drops.

D65VMRP—Fixed Time Delay Over/Undervoltage Relays



Contents

<i>Description</i>	<i>Page</i>
Current Monitoring Relays . . . . .	V5-T5-3
Phase Monitoring Relays . . . . .	V5-T5-5
Voltage Monitoring Relays	
Product Selection Guide . . . . .	V5-T5-14
D65VMRP Over/Undervoltage Relays (Fixed Time Delay)	
Product Selection . . . . .	V5-T5-16
Technical Data and Specifications . . . . .	V5-T5-16
Dimensions . . . . .	V5-T5-17
D65VAKP Over/Undervoltage Relays . . . . .	V5-T5-18
D65VWKP Voltage Band Relays . . . . .	V5-T5-21
Ground Fault Monitoring Relays . . . . .	V5-T5-24

**D65VMRP Over/Undervoltage Relays (Fixed Time Delay)**

**Product Description**

The D65VMRP Over/Undervoltage Relays provide protection to equipment where either an over- or undercurrent condition is potentially damaging. They are designed to operate when the operating voltage reaches a preset value and drop out when the operating voltage drops to a level below the preset value.

The pickup voltage setting is user-adjustable from 75 to 125% of the nominal voltage rating. As standard, the D65VMRP Series has a dropout voltage setting fixed at 95% of the pickup voltage setting. The relay energizes when the monitored voltage is above the pickup setting. The relay de-energizes when the monitored voltage is below the dropout setting for a period longer than the drop-out time delay, which is fixed at 500 ms.

**Application Description**

Each relay can be used as either an overvoltage or an undervoltage relay, depending on the output contact used.

**Overvoltage Relay**

Provides protection to equipment that cannot handle excess voltages. Uses a normally closed contact (NC). As long as the monitored voltage remains below the maximum voltage the equipment can withstand (pickup setting), the relay remains energized and the NC contact remains closed, keeping the load energized. If the operating voltage increases beyond the maximum rating of the equipment, the relay energizes and the NC contact opens, turning off the load. When the voltage falls below the dropout settings (hysteresis), the relay de-energizes and the NC contact re-closes, turning on the load.

**Undervoltage Relay**

Provides protection to equipment that is required to operate above a certain minimum voltage. Uses a normally open contact (NO). As long as the monitored voltage is above the minimum value required (pickup setting), the relay will energize and the NO contact closes, turning on the load. If the voltage drops below the dropout setting (the minimum voltage required minus hysteresis), the relay will de-energize and the NO contact will re-open, turning off the load.

**Features**

- Monitors AC single-phase and DC voltages
- Wide range of user-adjustable pickup with fixed dropout settings
- Fixed time delay on dropout of 500 ms
- LED indicates output relay status
- Compact plug-in case using industry standard 8-pin socket
- 10 A DPDT output contacts

**Fixed Time Delay Over/Undervoltage Current Monitoring**

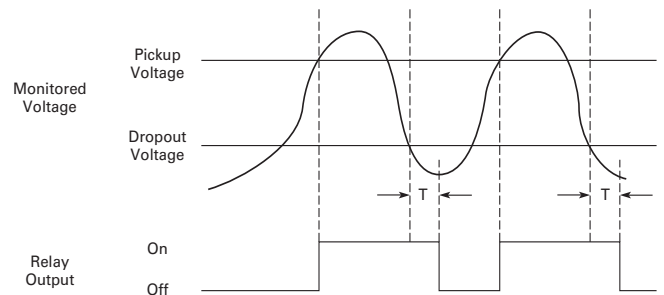



## Product Selection

D65VM

**D65VMRP Series—Over/Undervoltage Relay** <sup>①</sup>,  
**Adjustable Pickup, Fixed Dropout Settings** <sup>②</sup>

Nominal Voltage	Voltage Range Pickup	Dropout	Catalog Number
120 Vac	90–150 Vac	68–142 Vac	D65VMRPA

5

## Accessories

**D65VMRP Series—Over/Undervoltage Relays**

Description	Standard Pack	Catalog Number
8-pin socket	10	D3PA2
Hold-down spring	10	D65CHDS

## Technical Data and Specifications

**D65V Series—Fixed and Adjustable Time Delay Over/Undervoltage Relays**
**D65VMRP and D65VAKP Series, Over/Undervoltage Relays**

Description	Specification
Voltage tolerance	±50% of nominal voltage; AC voltages are 50/60 Hz No supply (input) voltage is required
Load (burden)	Less than 2 VA (12–120 V); 30 VA (240 V and 480 V)
Current settings	
Pickup	Adjustable from 75 to 125% of nominal voltage
Dropout	Fixed at 95% of the pickup setting for D65VMRP Adjustable from 75 to 95% of the pickup setting for D65VAKP
Temperature	–20 to 131 °F (–28 to 65 °C)
Response times	
Pickup	500 ms
Dropout	Fixed 500 ms for D65VMRP Adjustable 0.1–10 seconds for D65VAKP
Output contacts	10 A at 240 Vac, 7 A at 30 Vdc, 1/4 hp at 120/240 Vac, C300
Mechanical life	10,000,000 operations
Electrical life	100,000 operations
Indicator LED	Red steady when relay is energized; green when relay is OFF
Transient protection	2000 V per IEC 61000-4-5 Level 3 (±2 kV)
Reset	Automatic
Mounting	Requires an 8-pin socket

**Notes**

① Time delay on dropout fixed at 500 ms.

② Dropout voltage is fixed at 95% of the adjusted pickup setting.

**Wiring Diagram**

**Wiring for 8-Pin Socket**

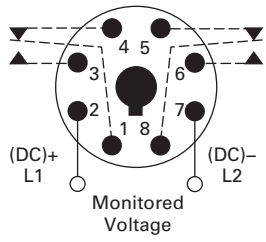

**Dimensions**

Approximate Dimensions in Inches (mm)

**D65V Series—Fixed and Adjustable Time Delay Over/Undervoltage Relays**

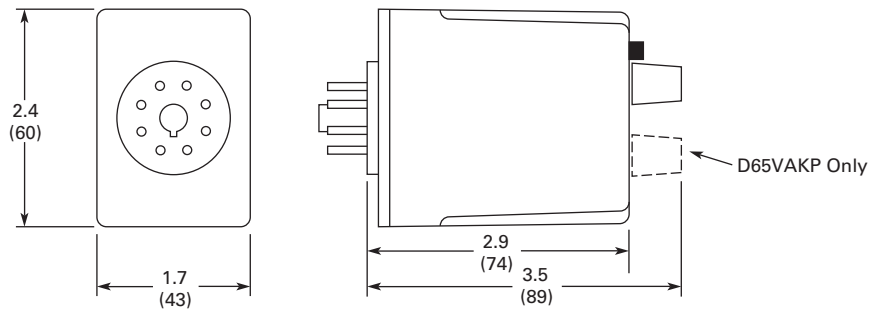

#### D65VAKP—Adjustable Time Delay Over/Undervoltage Relays



### D65VAKP Over/Undervoltage Relays (Adjustable Time Delay)

#### Product Description

The D65VAKP Over/Undervoltage Relays provide protection to equipment where either an over- or undercurrent condition is potentially damaging. They are designed to operate when the operating voltage reaches a preset value and drop out when the operating voltage drops to a level below the preset value.

The pickup voltage setting is user-adjustable from 75 to 125% of the nominal voltage rating. As standard, the D65VAKP has an adjustable dropout setting of 75–95%. The relay energizes when the monitored voltage is above the pickup setting. The relay de-energizes when the monitored voltage is below the dropout setting for a period longer than the dropout time delay, which is adjustable from 0.1 to 10 seconds. A fixed time delay of 500 ms is available with the D65VMP Series.

#### Application Description

Each relay can be used as either an overvoltage or an undervoltage relay, depending on the output contact used.

#### Overvoltage Relay

Provides protection to equipment that cannot handle excess voltages. Uses a normally closed contact (NC). As long as the monitored voltage remains below the maximum voltage the equipment can withstand (pickup setting), the relay remains energized and the NC contact remains closed, keeping the load energized. If the operating voltage increases beyond the maximum rating of the equipment, the relay energizes and the NC contact opens, turning off the load. When the voltage falls below the dropout settings (hysteresis), the relay de-energizes and the NC contact re-closes, turning on the load.

### Contents

#### Description

	<i>Page</i>
Current Monitoring Relays .....	<b>V5-T5-3</b>
Phase Monitoring Relays .....	<b>V5-T5-5</b>
Voltage Monitoring Relays	
Product Selection Guide .....	<b>V5-T5-14</b>
D65VMRP Over/Undervoltage Relays (Fixed Time Delay) .....	<b>V5-T5-15</b>
D65VAKP Over/Undervoltage Relays (Adjustable Time Delay)	
Product Selection .....	<b>V5-T5-19</b>
Technical Data and Specifications .....	<b>V5-T5-20</b>
Dimensions .....	<b>V5-T5-20</b>
D65VWKP Voltage Band Relays .....	<b>V5-T5-21</b>
Ground Fault Monitoring Relays .....	<b>V5-T5-24</b>

#### Features

- Monitors AC single-phase and DC voltages
- Wide range of user-adjustable pickup and dropout settings
- Adjustable time delay on dropout of 0.1–10 seconds
- LED indicates output relay status
- Compact plug-in case using industry standard 8-pin socket
- 10 A DPDT output contacts

#### Undervoltage Relay

Provides protection to equipment that is required to operate above a certain minimum voltage. Uses a normally open contact (NO). As long as the monitored voltage is above the minimum value required (pickup setting), the relay will energize and the NO contact closes, turning on the load. If the voltage drops below the dropout setting (the minimum voltage required minus hysteresis), the relay will de-energize and the NO contact will re-open, turning off the load.

#### Adjustable Time Delay Over/Undervoltage Current Monitoring

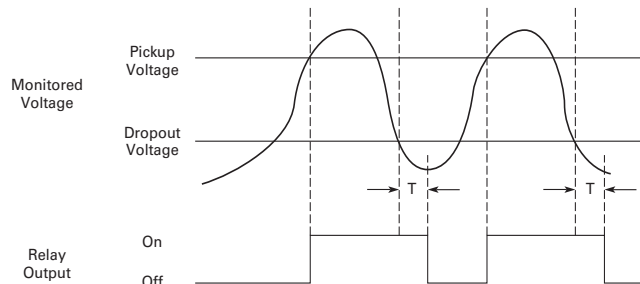

**Product Selection**

D65VA



**D65VAKP Series—Over/Undervoltage Relay <sup>①</sup>, Adjustable Pickup and Dropout Settings <sup>②</sup>**

Nominal Voltage	Voltage Range Pickup	Dropout	Catalog Number
120 Vac	90–150 Vac	68–142 Vac	<b>D65VAKPA</b>
12 Vdc	9–15 Vdc	7–14 Vdc	<b>D65VAKPR1</b>
24 Vdc	18–30 Vdc	14–38 Vdc	<b>D65VAKPT1</b>
48 Vdc	36–60 Vdc	27–57 Vdc	<b>D65VAKPW1</b>
110 Vdc	83–138 Vdc	62–130 Vdc	<b>D65VAKPA1</b>
240 Vac	180–300 Vac	135–285 Vac	<b>D65VAKPA2</b>
480 Vac	360–600 Vac	270–570 Vac	<b>D65VAKPA3</b>

**Accessories**

**D65VAKP Series—Over/Undervoltage Relays**

Description	Standard Pack	Catalog Number
8-pin socket	10	<b>D3PA2</b>
Hold-down spring	10	<b>D65CHDS</b>

**Notes**

- ① Time delay on dropout adjustable 0.1–10 sec.
- ② Dropout voltage is adjustable from 75 to 95% of the adjusted pickup setting.

#### Technical Data and Specifications

##### D65V Series—Fixed and Adjustable Time Delay Over/Undervoltage Relays

##### D65VMP and D65VAKP Series, Over/Undervoltage Relays

Description	Specification
Voltage tolerance	±50% of nominal voltage; AC voltages are 50/60 Hz No supply (input) voltage is required
Load (burden)	Less than 2 VA (12–120 V); 30 VA (240 V and 480 V)
Current settings	
Pickup	Adjustable from 75 to 125% of nominal voltage
Dropout	Fixed at 95% of the pickup setting for D65VMP Adjustable from 75 to 95% of the pickup setting for D65VAKP
Temperature	–18 to 149 °F (–28 to 65 °C)
Response times	
Pickup	500 ms
Dropout	Fixed 500 ms for D65VMP Adjustable 0.5–10 seconds for D65VAKP
Output contacts	10 A at 240 Vac, 7 A at 30 Vdc, 1/4 hp at 120/240 Vac, C300
Mechanical life	10,000,000 operations
Electrical life	100,000 operations
Indicator LED	Red steady when relay is energized; green when relay is OFF
Transient protection	2000 V per IEC 61000-4-5 Level 3 (±2 kV)
Reset	Automatic
Mounting	Requires an 8-pin socket

#### Wiring Diagram

##### Wiring for 8-Pin Socket

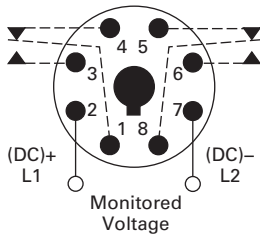

#### Dimensions

Approximate Dimensions in Inches (mm)

##### D65V Series—Fixed and Adjustable Time Delay Over/Undervoltage Relays

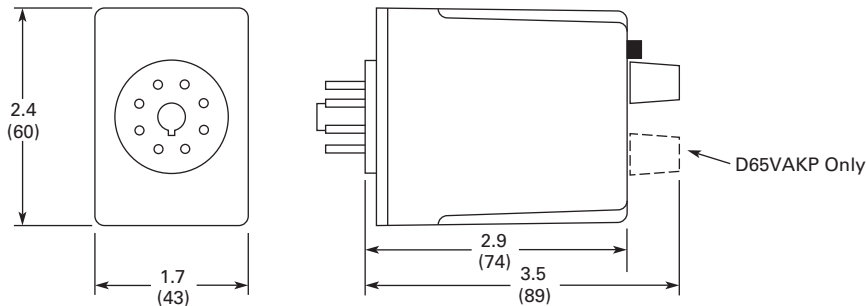

**D65VWKP Voltage Band Relays**



**D65VWKP Voltage Band Relays**

**Product Description**

The D65VWKP Series Voltage Band Relays provide protection to equipment that is required to operate within an upper and lower voltage limit. As long as the operating voltage remains within an over- and undervoltage range, the internal relay stays energized. If the operating voltage falls outside this range, the relay will drop out.

When nominal operating voltage is applied, the internal relay will energize (pickup). If the operating voltage falls outside the preset over trip point (adjustable 75–125% of nominal), or under trip point (adjustable 75–95% of pickup), for a period longer than the dropout time delay, the relay will de-energize (dropout). When the voltage returns to normal (within the preset over- and undervoltage trip points), the unit automatically resets and the relay energizes. The D65VWP has a 0.1–10 second dropout time.

**Contents**

<b>Description</b>	<b>Page</b>
Current Monitoring Relays . . . . .	<b>V5-T5-3</b>
Phase Monitoring Relays . . . . .	<b>V5-T5-5</b>
Voltage Monitoring Relays	
Product Selection Guide . . . . .	<b>V5-T5-14</b>
D65VMRP Over/Undervoltage Relays (Fixed Time Delay) . . . . .	<b>V5-T5-15</b>
D65VAKP Over/Undervoltage Relays (Adjustable Time Delay) . . . . .	<b>V5-T5-18</b>
D65VWKP Voltage Band Relays	
Product Selection . . . . .	<b>V5-T5-22</b>
Technical Data and Specifications . . . . .	<b>V5-T5-22</b>
Dimensions . . . . .	<b>V5-T5-23</b>
Ground Fault Monitoring Relays . . . . .	<b>V5-T5-24</b>

**Features**

- Monitors AC single-phase and DC voltages
- Provides voltage band (window) protection
- Wide range of user-adjustable overvoltage and undervoltage settings
- Adjustable time delay on dropout from 0.1 to 10 seconds
- LED indicates output relay status
- Compact plug-in case using industry standard 8-pin octal socket
- 10 A DPDT output contacts

**Voltage Band Relay Current Monitoring**

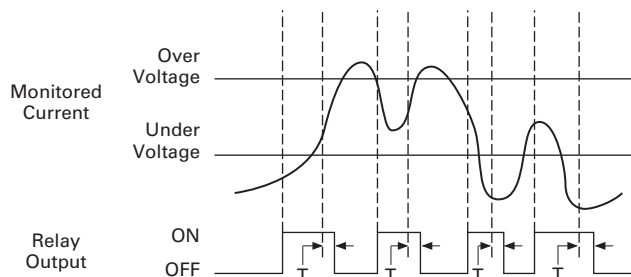

## Product Selection

D65VW\_

**D65VWKP Voltage Band Relays  
Adjustable Dropout Time Delay (0.1–10 Seconds)**

Nominal Voltage	Voltage Range		Catalog Number
	Over	Under	
120 Vac	90–150 Vac	68–142 Vac	D65VWKP

5

## Accessories

**D65VWKP Voltage Band Relays**

Description	Standard Pack	Catalog Number
8-pin socket	10	D3PA2
Hold-down spring	10	D65CHDS

## Technical Data and Specifications

**D65VWKP Series, Voltage Band Relays**

Description	Specification
Voltage tolerance	±50% of nominal voltage; AC voltages are 50/60 Hz No separate supply (input) voltage is required
Load (burden)	Less than 2 VA (12–120 V); 30 VA (240 V and 480 V)
Voltage settings	
Overvoltage	75–125% of nominal voltage
Undervoltage	75–95% of pickup voltage
Temperature	–18 to 149 °F (–28 to 65 °C)
Indicator LED	Red steady when relay is energized; green when relay is OFF
Reset	Automatic Contact Eaton for information on how to order a unit with manual reset
Response times	
Operate	500 ms
Release	Adjustable 0.1–10 seconds
Output contacts	10 A at 240 Vac, 7 A at 30 Vdc, 1/4 hp at 120/240 Vac, C300
Mechanical life	10,000,000 operations
Electrical life	100,000 operations
Transient protection	2000 V per IEC 61000-4-5 Level 3 (±2 kV)

**Wiring Diagram**

**Wiring for 8-Pin Socket**

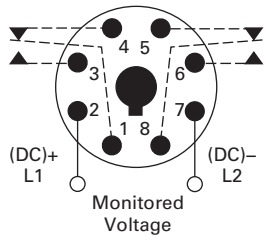

**Dimensions**

Approximate Dimensions in Inches (mm)

**D65VWKP Series, Voltage Band Relays**

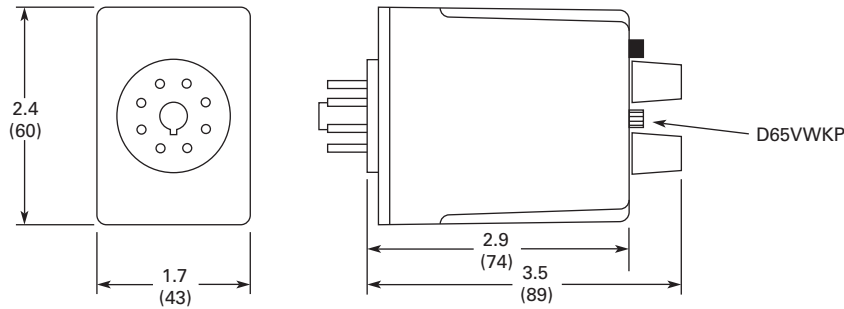



#### Ground Fault Relays and Monitors



5

#### Product Overview

##### D64R Series— Digital Ground Fault Relays

The new D64R digital ground fault relays are microprocessor-based and replace the previous generation of analog-based devices.

Microprocessor-based D64R GFRs combine more selectable features into a single model, which makes easier model selection and reduces spares inventory requirements.

These devices are designed to provide reliable detection of ground fault conditions on three-phase AC resistance grounded or solidly grounded electrical distribution systems.

##### D64L Series— Ground Fault Monitors

Type D64L ground fault monitors are designed to monitor ungrounded supplies on three-phase AC power systems up to 600 V. If an insulation fault develops anywhere on the system between the source and the load, the D64L will detect it and give an alarm or trip, depending on the adjustable field settings selected.

The D64L is ideally suited for systems supplied from the secondary of either an ungrounded delta or an ungrounded wye connected transformer.

#### Contents

##### Description

	<i>Page</i>
Current Monitoring Relays .....	<b>V5-T5-3</b>
Phase Monitoring Relays .....	<b>V5-T5-5</b>
Voltage Monitoring Relays .....	<b>V5-T5-13</b>
Ground Fault Relays and Monitors	
D64R Series—Digital Ground Fault Relays . . . .	<b>V5-T5-25</b>
D64L Series—Ground Fault Monitors . . . . .	<b>V5-T5-35</b>

Because D64L has high immunity from the effects of voltage transients and cable capacitance, it may be applied in automotive, sub-sea, mobile lighting, portable generators, sensitive equipment and other installations where ungrounded systems are used extensively.

The user is able to individually set the alarm level and the trip level from 20%–80% of the maximum leakage current limit of the D64L selected. Any leakage current above the alarm level will activate the alarm relay and light the alarm LED. Should the leakage current rise above the trip level, the trip relay and trip LED will activate.

**D64R Series—Digital Ground Fault Relays**



**Contents**

<i><b>Description</b></i>	<i><b>Page</b></i>
Current Monitoring Relays . . . . .	<b>V5-T5-3</b>
Phase Monitoring Relays . . . . .	<b>V5-T5-5</b>
Voltage Monitoring Relays . . . . .	<b>V5-T5-13</b>
Ground Fault Relays and Monitors	
D64R Series—Digital Ground Fault Relays	
Features . . . . .	<b>V5-T5-26</b>
Options . . . . .	<b>V5-T5-26</b>
Standards and Certifications . . . . .	<b>V5-T5-26</b>
Product Selection . . . . .	<b>V5-T5-27</b>
Accessories . . . . .	<b>V5-T5-28</b>
Technical Data and Specifications . . . . .	<b>V5-T5-29</b>
Wiring Diagrams . . . . .	<b>V5-T5-30</b>
Dimensions . . . . .	<b>V5-T5-32</b>
D64L Series—Ground Fault Monitors . . . . .	<b>V5-T5-35</b>

**D64R Series—Digital Ground Fault Relays**

**Product Description**

The new D64R digital ground fault relays are microprocessor-based and replace the previous generation of analog-based devices.

Microprocessor-based D64R GFRs combine more selectable features into a single model, which makes easier model selection and reduces spares inventory requirements.

These devices are designed to provide reliable detection of ground fault conditions on three-phase AC resistance grounded or solidly grounded electrical distribution systems.

**Application Description**

D64R ground fault relays feature adjustable trip settings for both trip current and trip time. This allows the user to set the ground fault trip current just above the “charging” current of the system. This prevents nuisance tripping and provides meaningful protection of additional ground fault leakage currents.

Every system has a “charging” current that can cause nuisance tripping if the trip current is set too low. The “charging” current is caused by the capacitance-to-ground effect of phase conductors in a system and will vary depending on:

- The overall length of the cables
- The types of loads
- The quality of the insulation on the phase conductors
- Surrounding equipment grounding, cable trays, junction boxes, and so on
- Type and size of transformer

A “rule-of-thumb” for systems 600 V and lower: the “charging” current is 0.5 A per 1000 kVA of transformer capacity.

## Features

### Standard Models

- Built-in current sensor (zero sequence CT)
- Run and trip indicating LEDs
- Built-in harmonic filtering for variable frequency drives or standard 50/60 Hz applications (see **Page V5-T5-29** for frequency response range)
- DIN rail or panel mounting
- Rugged epoxy encapsulated construction
- Pull-apart terminal block connectors
- Form “Z” (4 terminal) NO and NC output contacts, 5 amps at 250 Vac
- Pulsed (trip) auto reset mode

The pulsed (trip) auto reset mode is designed for applications where the output relay is operating a shunt trip device. The D64R relay resets automatically, three seconds after the ground fault current is interrupted by the tripping action of the circuit breaker. This opens the output contact wired to the shunt trip coil and prevents damage to the internal mechanism of the circuit breaker in the event that the operator tries to reset the circuit breaker.

- Suitable for use on 600 V systems—may be applied on higher voltages by using separate CTs with power conductors insulated for the system voltage
- Built-in test circuitry—no external power or additional wiring is necessary—tests trip time and current settings
- Communications port (standard RJ-10 jack) for connection to optional remote display (D64D1) and door mounted units (on D64RPB100 models only)
- Fail-safe selectable mode (on D64RPB100 models only)

In the fail-safe mode, the relay is energized when control voltage is applied and will trip when either:

- a ground fault trip is detected or,
- there is a loss of control power.

### Service Protection Models

- Service protection models require C311CT 10,000:1 ratio CTs
- Trip current range of 50 to 1200 A
- Green LED indicates “Power On”
- Circuit breaker toggle position indicates “Normal” or “Tripped” condition
- Form “C” (3 terminal) NO-NC output contacts, 3 amps at 250 Vac
- Frequency response range of 40 to 200 Hz
- Zone interlocking feature with green LED to indicate “Grading Input Active” and DIP switch array for zone grading backup delay and block signal override (on D64RPBH15 model only)
- Test button to invoke test at 20 A trip current—tests external CT, electronics and circuit breaker trip
- Fail-safe selectable mode (see above for description)
- Inhibit selectable mode—this allows the relay to differentiate between normal ground fault trip levels and short circuit conditions

The trip inhibit function is useful when the relay is being used to trip a contactor or motor starter on a solidly grounded system. Under a bolted fault condition, the relay would trip and could cause the contactor or motor starter to interrupt the high fault current with harmful results. By inhibiting the trip, the ground fault relay will not trip on bolted faults and will allow the upstream protective device to clear the fault instead.

- Through-the-door or rear panel mounting

### Options

- Other ranges of trip currents and times
- Fixed trip current and times
- Other control voltages
- Custom packaging for volume OEM requirements
- Separate outputs for alarming vs trip
- Relays for neutral grounding resistance monitoring
- Relays for ground fault detection on DC power systems
- Other sizes of current transformers

## Standards and Certifications

- UL 1053
  - Ground Fault Sensing and Relaying Equipment, Class 1 (UL File # E195341)
- CSA® C22.2 No. 144-M91
  - Ground Fault Circuit Interrupters (CSA File # 700103)
- CE Mark—Declaration of Conformity
- IEC 60755
  - General Requirements for residual current operated protective devices
- EN 50081-1
  - Electromagnetic compatibility (radiated emission), “household” directive

D64R ground fault relays are UL listed as Class 1 devices designed to protect electrical equipment against extensive damage from arcing ground faults.



**Product Selection**

**Standard Models**

When Ordering, Specify

- Catalog number of relay from tables
- Catalog number of zero sequence current transformers, if or when required, remote digital display or remote indicator units

**Ground Fault Relay with Built-In Current Sensor**

	Control Power	Trip Current Range	Current Transformer Selection	Catalog Number
<b>D64RP18</b> without Plug-In 	24–240 Vac/Vdc	30 mA–6 A	Built-in 1.1 in CT <sup>①</sup> If external CT is required for specific application, select 500:1 ratio CT <sup>②</sup>	<b>D64RP18</b>
<b>D64RPB100</b> Full-Featured Ground Fault Relay 	24–240 Vac/Vdc	30 mA–9 A	Built-in 2.0 in CT <sup>③</sup> If external CT is required for specific application, select 500:1 ratio CT <sup>②</sup>	<b>D64RPB100_</b>
		3–900 A	Select 500:5 ratio CT <sup>④</sup>	<b>D64RPB100_</b>
		30–9000 A	Select 5000:5 ratio CT <sup>④</sup>	<b>D64RPB100_</b>
<b>D64RPB30</b> without Internal CT 	24–240 Vac/Vdc	30 mA–9 A	Requires use of applicable C331CT, see <b>Page V5-T5-28</b> .	<b>D64RPB30</b>

**Service Protection Models**

When Ordering, Specify

- Catalog number of relay from tables
- Catalog number of zero sequence current transformers, if or when required, remote digital display or remote indicator units

**Ground Fault Relay**

**D64RPBH15** Ground Fault Relay with Zone Interlocking



Control Power	Zone Interlocking Feature	Trip Current Range	Current Transformer Selection	Catalog Number
120 Vac	No	50 A–1200 A	Select 10,000:1 ratio CT <sup>⑤</sup>	<b>D64RPBH13</b>
120 Vac	Yes	50 A–1200 A	Select 10,000:1 ratio CT <sup>⑤</sup>	<b>D64RPBH15</b>

**Notes**

- ① Maximum allowable continuous current through built-in CT is 100 amps.
- ② For 500:1 ratio CTs, select from Protective Relays in **Volume 3—Power Distribution and Control Assemblies**, CA08100004E, Tab 9, section 9.3.
- ③ Maximum allowable continuous current through built-in CT is 200 amps.
- ④ For 500:5 or 5000:5 ratio CTs, select any commercially available 5 amp secondary CT with the same ratio.
- ⑤ For 10,000:1 ratio CTs, select from Protective Relays in **Volume 3—Power Distribution and Control Assemblies**, CA08100004E, Tab 9, section 9.3.

#### Accessories

##### Zero Sequence Current Transformers

- A complete size range of zero sequence CTs designed specifically for use with D64R relays provide excellent coupling to the monitored circuit. This means accurate ground fault leakage current detection over the full setting range of the relay with no saturation
- Built-in back-to-back zeners across the output terminals of all 500:1 and 10,000:1 CTs provide personnel safety should the secondary circuit be opened
- Rectangular split core CTs make retro-fitting easy
- All CTs are epoxy potted, panel mounted and come with either secondary screw terminals or threaded studs
- The core is very high grade silicon iron to give superior coupling characteristics and to withstand high shock and vibration
- All CTs are 600 Volt class. They may be used on higher voltage circuits provided that power conductors are insulated for the system voltage

#### Zero Sequence Current Transformers for D64RP18 and D64RPB100 Relay <sup>①②③</sup>

##### C311CT9



##### Toroidal

Description/Window Size	Ratio 500:1 CTs <sup>④</sup>
	Catalog Number
1.1 in (28 mm)	C311CT8
1.8 in (46 mm)	C311CT1
2.5 in (65 mm)	C311CT9
3.5 in (90 mm)	C311CT2
5.7 in (144 mm)	C311CT5
9.5 in (240 mm)	C311CT6

##### Split Core (Rectangular/Square)

Description/Window Size	Ratio 500:1 CTs <sup>④</sup>
	Catalog Number
5.9 x 6.7 in (150 x 170 mm)	C311CT3
4.0 x 13.8 in (100 x 350 mm)	C311CT4
11.8 x 11.8 in (300 x 300 mm)	C311CT7

#### Zero Sequence Current Transformers for D64RPBH13 and D64RPBH15 Relays

##### Toroidal

Description/Window Size	Ratio 10,000:1 CTs <sup>⑤</sup>
	Catalog Number
2.5 in (65 mm)	C311CT11
5.7 in (144 mm)	C311CT12
9.5 in (240 mm)	C311CT13

##### Notes

- ① D64RP18 relays use 500:1 ratio CTs if needed.
- ② D64RPB100 relays can use 500:1 ratio CTs when needed for 30 mA–9 A, 500:5 ratio for 3 A–900 A and 5000:5 ratio for 30 A–9000 A trip current ranges.
- ③ For 500:5 or 5000:5 ratio CTs, select any commercially available 5 Amp secondary CT with the same ratio.
- ④ The maximum allowable continuous current through CTs is 1000 A.
- ⑤ The maximum allowable continuous current through 10,000:1 ratio CTs is 10,000 A.

**D64D1 Digital Display Unit**

The D64D1 digital display unit is connected to the D64RPB100 by up to 30 ft (10m) of standard four-wire telephone type cable. It is supplied with door-mounting hardware. It provides the following remote indications and functions:

- Continuous reading of actual ground fault current, employing auto ranging
- Display of the pre-trip ground fault current, after a trip has occurred (flashing display)
- Display of the trip current setting, after a Test Trip has been activated
- Green RUN LED, red TRIP LED
- TEST and RESET pushbuttons. The RESET button must be held pressed before the TEST is pressed to invoke the test procedure. The function of this button can be enabled/disabled by inserting the interconnecting cable from the D64RPB100 relay into one of two sockets, TEST ON or TEST OFF, on the right side of the display
- Pushing VERIFY pushbutton shows if D64RPB100 tripped due to a ground fault prior to loss of its control voltage—red TRIP LED lights, or if there was no ground fault trip—green RUN LED lights. This indication will remain available for at least ten hours
- The Numerical LCD window displays actual ground fault current in amps. When a 5000:5 ratio interposing CT is used, all displayed values are to be interpreted as kA rather than amps

**D64D1**



**Remote Display Unit for D64RPB100**

**Description**

Remote digital display with numerical LCD, RUN and TRIP LEDs, TEST, RESET and VERIFY pushbuttons: C/W 3 ft (1 m) of cable.

**Catalog Number**

**D64D1**

**Technical Data and Specifications**

**D64R Series—Digital Ground Fault Relays**

Catalog Number	Control Power Volts)	Frequency Response (Hz)	Trip Current Range		Trip Time Delay Range		Built-In Current Sensor	External Current Transformer		Test/Reset Provision	
			Min.	Max.	Min.	Max.		Required	Ratio	Pushbutton on Cover	Remote
<b>D64RP18</b>	24–240 Vac/Vdc non-isolated	45–450 Hz	30 mA	6 A	20 ms	500 ms	1.1 in	Optional	500:1	No	Pushbutton
<b>D64RPB100</b>	24–240 Vac/Vdc isolated	45–450 Hz	30 mA	9 A	20 ms	5 sec	2.0 in	Optional	500:1	Yes	Pushbutton or RJ-11 Communications port
			3 A	900 A				Required	500:5		
			30 A	9000 A				Required	5000:5		
<b>D64RPBH13</b>	120 Vac	45–200 Hz	50 A	1200 A	35 ms	1 sec	None	Required	10000:1	Yes	Pushbutton
<b>D64RPBH15</b> ①	120 Vac	40–200 Hz	50 A	1200 A	35 ms	1 sec	None	Required	10000:1	Yes	Pushbutton

**Note**

① With zone interlocking feature.

#### Wiring Diagrams

**Typical Field Connection of D64RP18 Using Built-In Current Transformer**

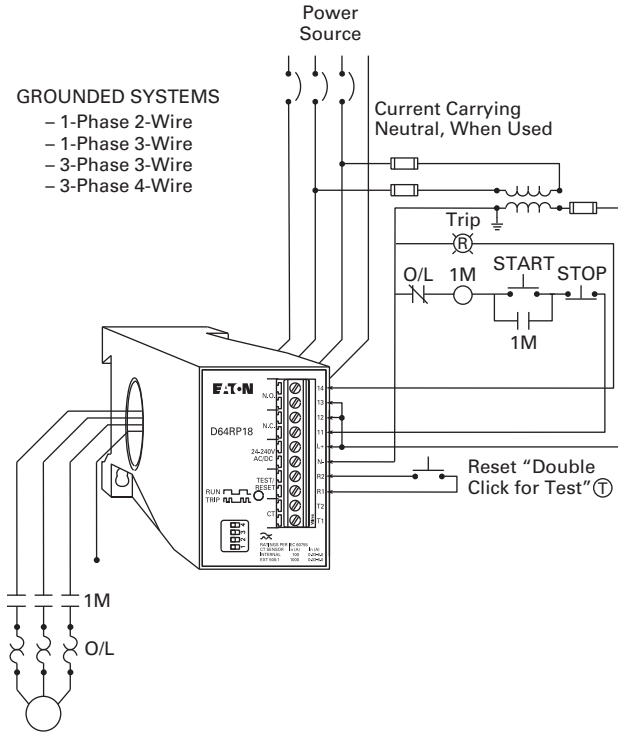

**Typical Field Connection of D64RPB100 Using Built-In Current Transformer and Remote Test/Reset**

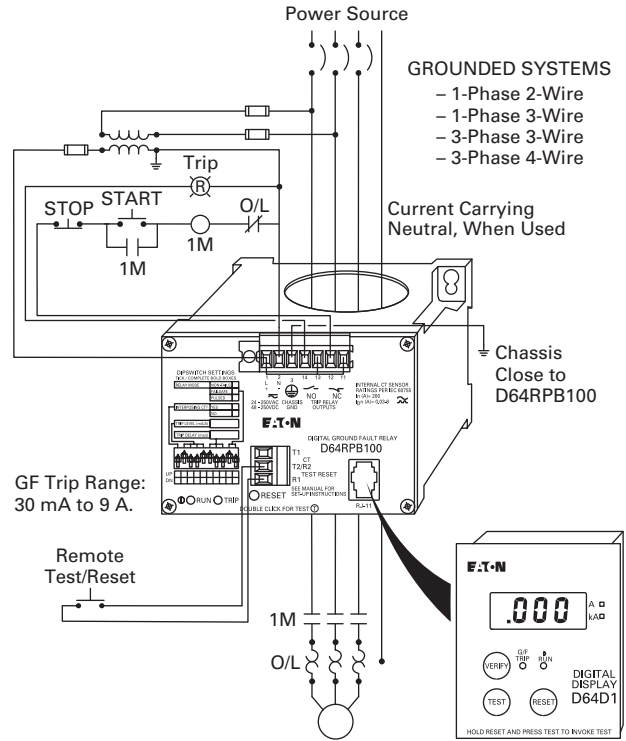

**Typical Field Connection of D64RP18 with External 500:1 Current Transformer and Pulsed Trip-Auto Reset**

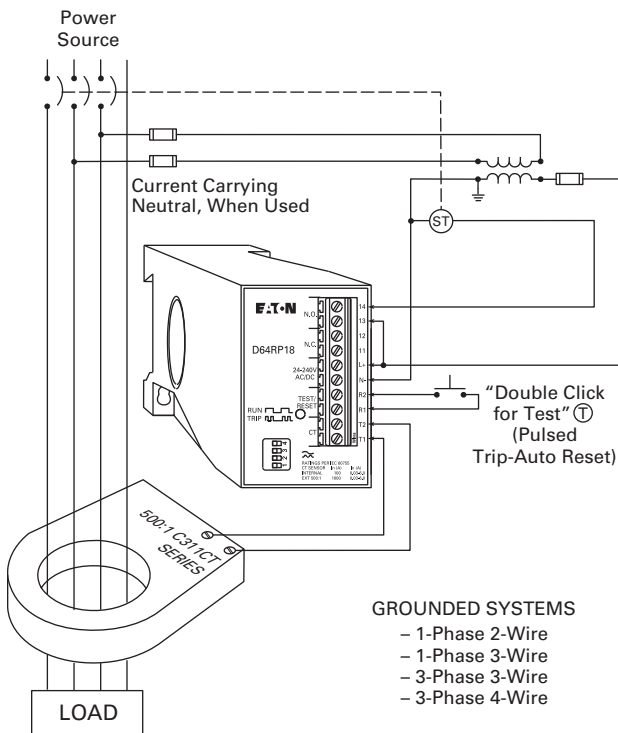

**Typical Field Connection of D64RPB100 with Interposing 500:5 Current Transformer, Pulsed Trip-Auto Reset for Shunt Trip Breaker**

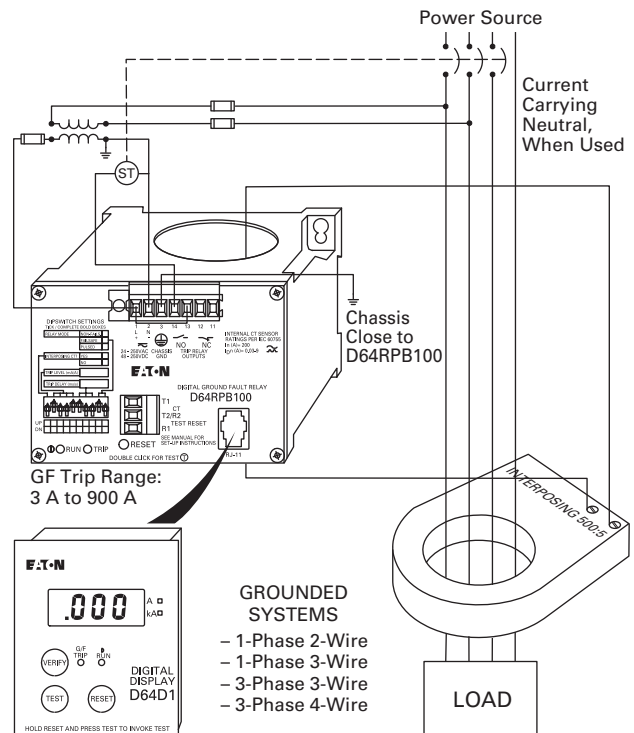

**Typical Field Connection of D64RPB100 with External 500:1 Current Transformer (C311CT Series) Pulsed Trip-Auto Reset for Shunt Trip Breaker**

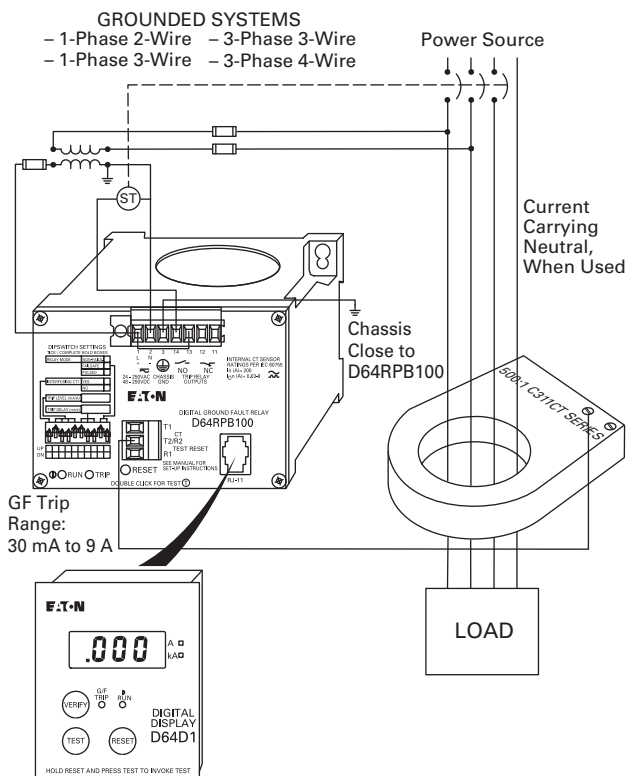

**D64RPBH15 Typical Field Connection**

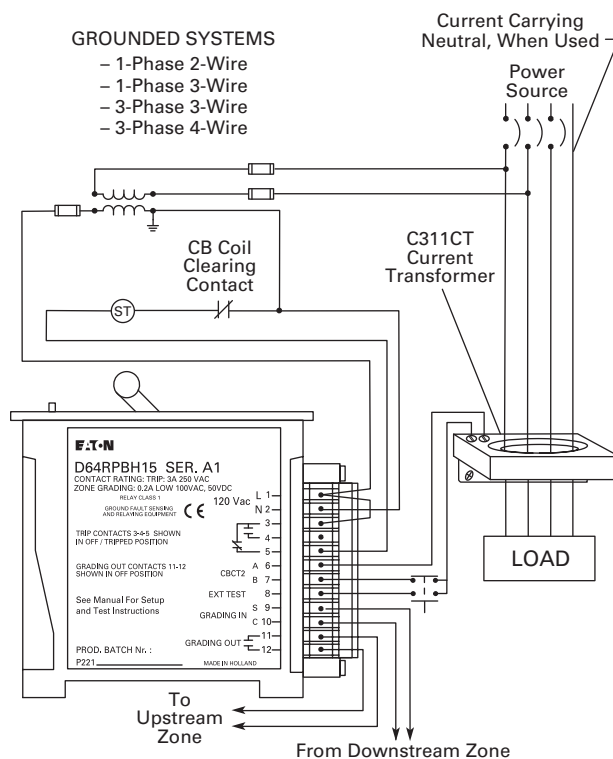

**D64RPBH13 Typical Field Connections**

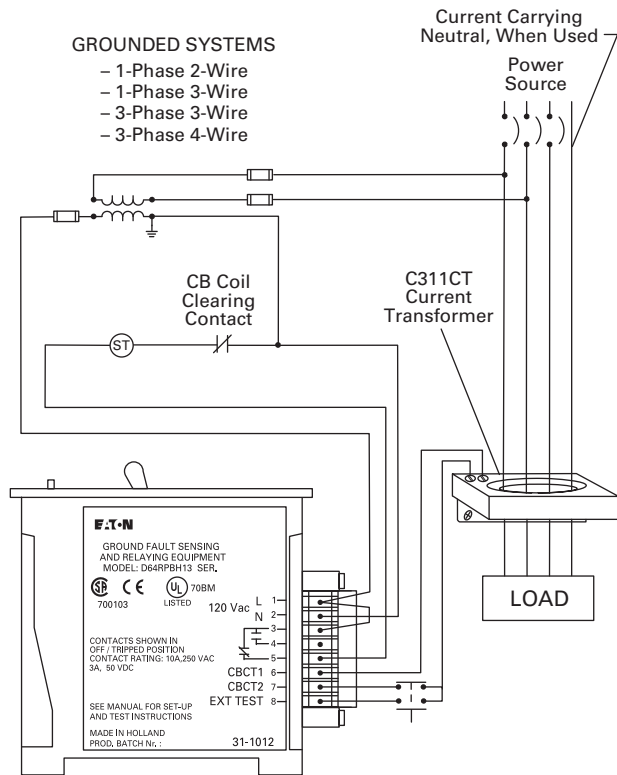



# 5.1

## Motor Protection and Monitoring

### Monitoring Relays

#### Dimensions

Approximate Dimensions in Inches (mm)

#### D64RP18

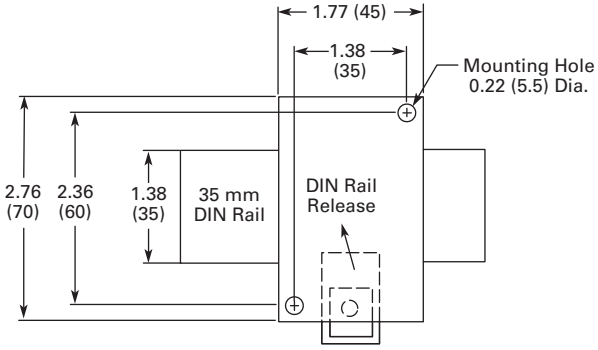

Rear Panel Mounting DIN Rail or Two Screw

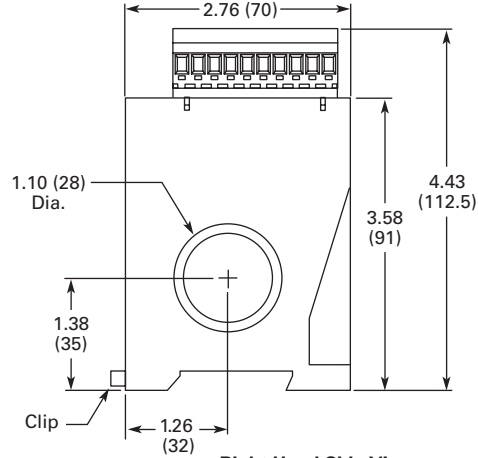

Right Hand Side View

#### D64RPB100

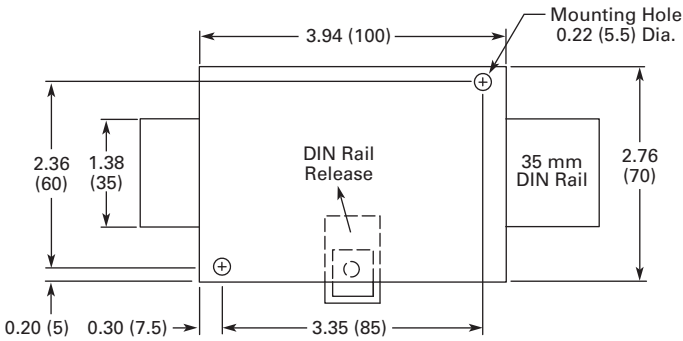

Rear Panel Mounting DIN Rail or Two Screw

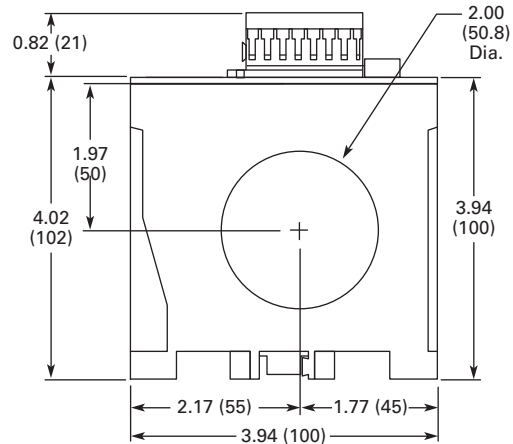

Bottom Side View

Approximate Dimensions in Inches (mm)

### D64RPBH13 and D64RPBH15

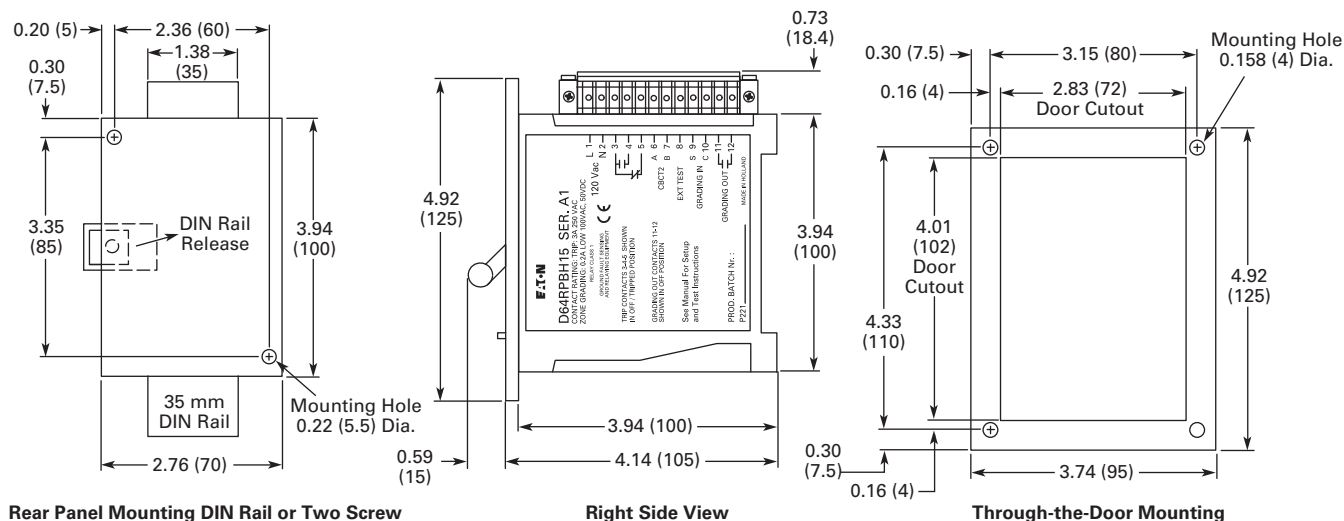

### D64D1 and D64D2

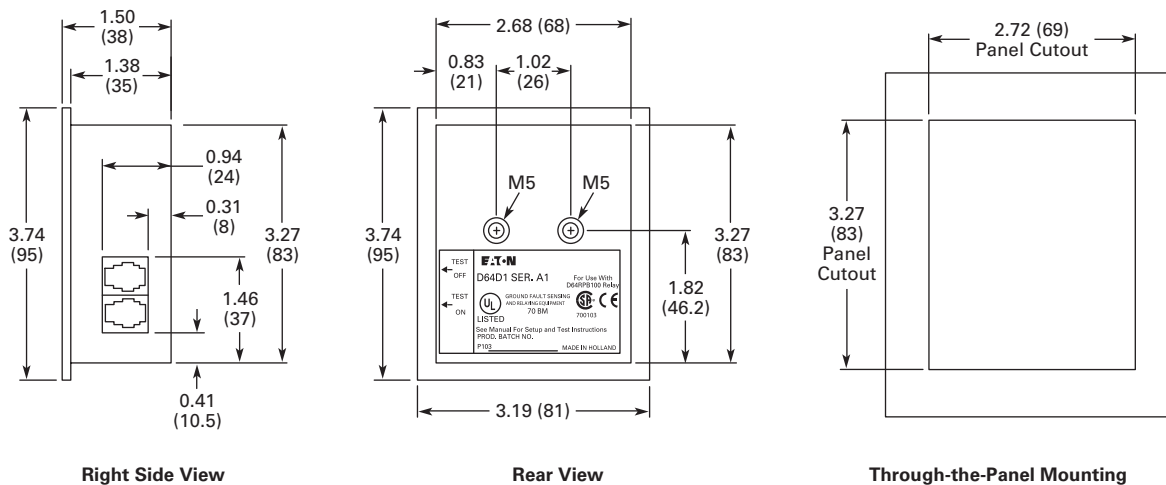

# 5.1

## Motor Protection and Monitoring

### Monitoring Relays

Approximate Dimensions in Inches (mm)

#### C311CT Series

5

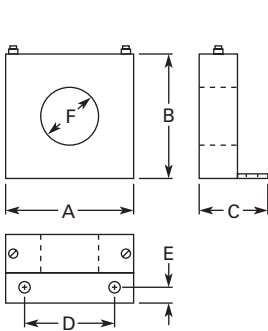

Figure A

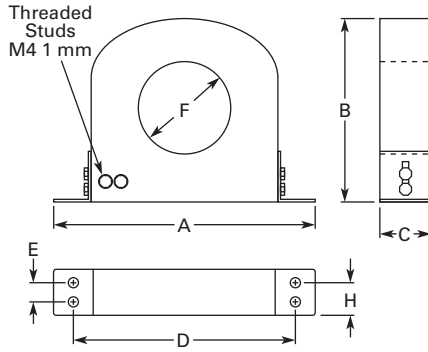

Figure B

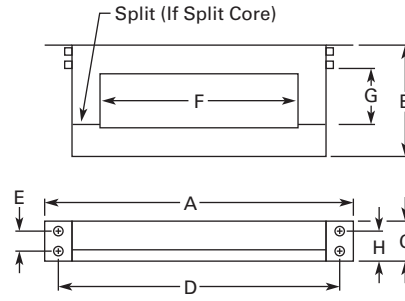

Figure C

Note: All Mounting Holes Are 0.25 (6.4) Dia.

Catalog Number	Figure	Wide A	High B	Deep C	Mounting D	Mounting E	F	G	H
C311CT1	A	3.35 (85)	3.35 (85)	1.57 (40)	0.98 (25)	0.39 (10)	1.81 (46)	—	—
C311CT2	B	7.30 (185)	5.50 (140)	1.20 (30)	6.42 (163)	0.59 (15)	3.54 (90)	—	0.89 (22.5)
C311CT3	C	13.58 (345)	8.75 (222)	1.57 (40)	12.80 (325)	0.59 (15)	6.70 (170)	5.90 (150)	0.89 (22.5)
C311CT4	C	20.87 (530)	7.87 (200)	1.57 (40)	20.08 (510)	0.59 (15)	13.78 (350)	3.94 (100)	0.89 (22.5)
C311CT5	B	10.12 (257)	8.27 (210)	1.46 (37)	9.33 (237)	0.59 (15)	5.70 (145)	—	0.89 (22.5)
C311CT6	B	13.86 (352)	11.89 (302)	1.46 (37)	13.07 (332)	0.59 (15)	9.45 (240)	—	0.89 (22.5)
C311CT8	A	2.17 (55)	2.56 (65)	2.20 (56)	0.98 (25)	0.59 (15)	1.10 (28)	—	—
C311CT9	B	6.68 (167)	4.84 (123)	1.18 (30)	5.78 (147)	0.59 (15)	2.56 (65)	—	0.89 (22.5)
C311CT11	B	6.68 (167)	4.84 (123)	1.18 (30)	5.78 (147)	0.59 (15)	2.56 (65)	—	0.89 (22.5)
C311CT12	B	10.12 (257)	8.27 (210)	1.85 (47)	9.33 (237)	0.59 (15)	5.70 (145)	—	0.89 (22.5)
C311CT13	B	13.86 (352)	11.89 (302)	1.85 (47)	13.07 (332)	0.59 (15)	9.45 (240)	—	0.89 (22.5)

D64L Series—Ground Fault Monitors



Contents

<i>Description</i>	<i>Page</i>
Current Monitoring Relays . . . . .	V5-T5-3
Phase Monitoring Relays . . . . .	V5-T5-5
Voltage Monitoring Relays . . . . .	V5-T5-13
Ground Fault Relays and Monitors	
D64R Series—Digital Ground Fault Relays . . . . .	V5-T5-25
D64L Series—Ground Fault Monitors	
Product Selection . . . . .	V5-T5-36
Wiring Diagram . . . . .	V5-T5-36
Dimensions . . . . .	V5-T5-36

D64L Series—Ground Fault Monitors

Product Description

Type D64L ground fault monitors are designed to monitor ungrounded supplies on three-phase AC power systems up to 600 V. If an insulation fault develops anywhere on the system between the source and the load, the D64L will detect it and give an alarm or trip, depending on the adjustable field settings selected.

The D64L is ideally suited for systems supplied from the secondary of either an ungrounded delta or an ungrounded wye connected transformer.

Because D64L has high immunity from the effects of voltage transients and cable capacitance, it may be applied in automotive, sub-sea, mobile lighting, portable generators, sensitive equipment and other installations where ungrounded systems are used extensively.

The user is able to individually set the alarm level and the trip level from 20%–80% of the maximum leakage current limit of the D64L selected. Any leakage current above the alarm level will activate the alarm relay and light the alarm LED. Should the leakage current rise above the trip level, the trip relay and trip LED will activate.

Features

- Adjustable leakage current limit setting (20 mA, 35 mA or 50 mA). Factory set at 20 mA
  - Built-in RESET button on all models
  - Selectable fail-safe/non-fail-safe operation
  - Auto reset after alarm condition
  - Selectable auto/manual reset after trip
  - Three LEDs for POWER ON, ALARM and TRIP
  - Three LEDs to indicate which phase is faulted
  - Adjustable alarm setting 20%–80% of leakage current limit
  - Adjustable trip setting 20%–80% of leakage current limit
  - 70 ms response time for alarm and trip level. Resample time—2 seconds
  - Minimum alarm signal duration—70 ms
  - 110/120 V or 220/240 V 50/60 Hz control power, 4 VA
  - Isolated voltage free Form Z NO and NC contacts on both alarm and trip relays, 5 A at 250 Vac
  - 30 A 600 V screw terminals, 12 AWG capacity, for phase and ground connections
  - 10 A 300 V screw clamp terminals, 12 AWG capacity for relay outputs and control supply
  - CSA certified
  - 35 mm DIN rail or two screw mounting
- Suggested Fuse Block and Fuses**
- DIN rail mounting
    - 1—C350BD3C61 600 V 30 A three-pole fuse block
    - 3—Class CC 600 V 5 A fuses

#### Product Selection

##### When Ordering, Specify

- Catalog number of ground fault monitor
- Catalog number of fuse block and fuses as required

#### Fuse Block

Mounting Type	Fuse Holder Rating	Fuse Type	Catalog Number
DIN rail	600 V 30 A three-pole	Class CC 600 V 5 A	WMR633G

#### Line Insulation Monitors

Line Voltage Range 50/60 Hz	Fuse Type	Catalog Number
380–600 V	110/120 V 50/60 Hz	D64L2A
	220/240 V 50/60 Hz	D64L2B

#### Wiring Diagram

##### D64L Series—Ground Fault Monitors

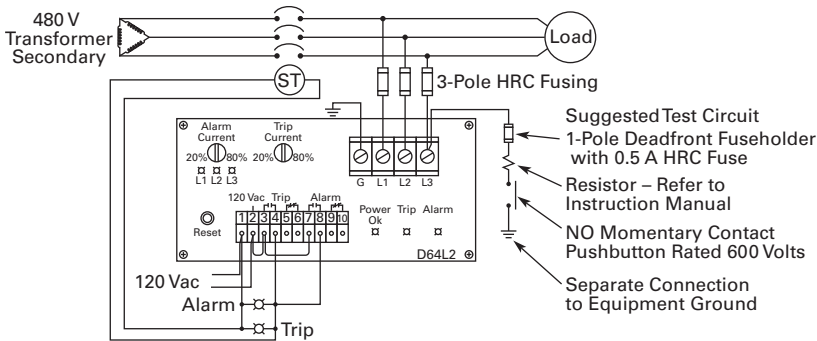

#### Dimensions

Approximate Dimensions in Inches (mm)

##### D64L Series—Ground Fault Monitors

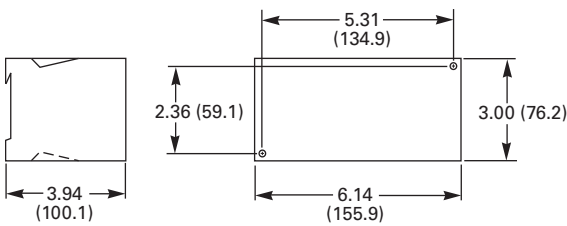

**Motor Protection Circuit Breakers**



**Contents**

Motor Protection Circuit Breakers (MPCB)

**Motor Protection Circuit Breakers (MPCB)**

**Product Description**

- Eliminates need for separate overload relay

**Application Description**

- Can be used with contactor to eliminate need for overload relay and still create manual motor control
- Meets requirement for motor branch protection, including:
  - Disconnecting means
  - Branch circuit short circuit protection
  - Overload protection

**Features and Benefits**

- Phase imbalance protection
- Phase loss protection
- Hot trip/cold trip
- High load alarm
- Pre-detection trip relay option
- Class 10, 15, 20, 30 protection

**Standards and Certifications**

- IEC 60947-2
- UL 489 100% rated
- UL 508
- CSA C22.2



**Reference**

Refer to **Volume 4—Circuit Protection**, CA08100005E, Tab 2, section 2.2 for additional product information.

<b>Motor Protection Circuit Breakers</b>	<b>Tab Section</b>
Product Selection . . . . .	<b>2.2</b>
Technical Data and Specifications . . . . .	<b>2.2</b>

#### Manual Motor Protection



5

#### Contents

##### Description

	<i>Page</i>
Manual Motor Protection	
Features and Benefits . . . . .	<b>V5-T5-39</b>
Catalog Number Selection . . . . .	<b>V5-T5-39</b>
Reference . . . . .	<b>V5-T5-39</b>

### Manual Motor Protectors—XTPB, XTPR and XTPE

#### Product Description

Eaton’s new **XT** family of manual motor protectors (MMPs) features a pushbutton or rotary ON/OFF manual disconnect, Class 10 adjustable bimetallic overload relay and fixed magnetic short-circuit trip capability in one compact unit. Two frame sizes are available: Frame B (45 mm) for motors with FLA ratings up to 32 A and Frame D (55 mm) covers motor FLA ratings up to 65 A.

#### Application Description

The XTPB and XTPR MMPs can be used in the following applications.

##### **Motor Protective Circuit Breaker**

In many countries outside of the United States and Canada, especially Europe, the MMPs are tested and classified as thermal-magnetic circuit breakers for use in motor branch circuits. This can be an important consideration for all companies who export their equipment and machines internationally. Both the XTPB and XTPR conform to IEC/EN 60947 and have the CE Mark.

##### **Manual Motor Protectors**

The XTPB and XTPR MMPs are UL listed under UL 508 as manual motor protectors. They provide an economical solution for applications requiring simple manual starting and stopping of motors. When used as a manual starter, they are typically installed in an enclosure. Many enclosures are offered as accessories for the MMPs. Separate short-circuit protective devices, such as circuit breakers or fuses, are wired ahead of the MMPs. The short-circuit protective device should be sized per the NEC and should not exceed 400% of the maximum FLA dial setting of the MMP.

##### **Individual Branch Motor Applications**

A UL 508 Type E self-protected manual combination starter/motor controller consists of a single device possessing four essential elements: disconnect, short circuit protection, motor controller, and motor overload protection. Some MMPs require use of a lineside adapter for this type of approval. When tested as an official combination by UL, this device takes the place of a fuse-starter or breaker-starter, **XT** Type E MMPs are self-protected, meaning they do not need additional short circuit protection of a fuse or breaker. Type E devices can also be used with a contactor or other types of UL approved controllers. If tested with a contactor, the combination motor controller becomes a Type F device. See Tab 1 of this volume, section 1.1 for XTFC Type F devices.

**Features and Benefits**

- ON/OFF rotary handle with lockout provision
- Visible trip indication
- Class 10 overload protection
- Phase loss sensitivity
- Ambient temperature compensation to IEC/EN 60947, VDE 0660
- Fixed short-circuit trip—14 times maximum setting of overload FLA dial
- Type 2 coordination per IEC 947
- Identification markers standard on starter faceplate
- Motor applications from 0.1 A to 65 A
- Built-in heater and magnetic trip elements to protect the motor
- Adjustment dial for setting motor FLA
- DIN rail mount
- Terminal types available:
  - Screw terminals
  - Screw (line) and spring cage (load) terminals
  - Spring cage terminals

- Accessories include:
  - Front and side auxiliary contacts
  - Trip indicating contacts
  - Tamperproof cover for OLR dial
  - Undervoltage release
  - Shunt trip
  - Through-the-door operators
- Enclosures
- Three-phase line side connecting links

**Standards and Certifications**

- CE approved
- UL listed File No. E245398
- UL 508 group motor and Type E compliant
- IEC/EN 60947
- CSA File 229767, Class 3211-05
- DIN VDE 0660 Part 100, Part 101 and Part 102



**Catalog Number Selection**

**XT Manual Motor Protectors**

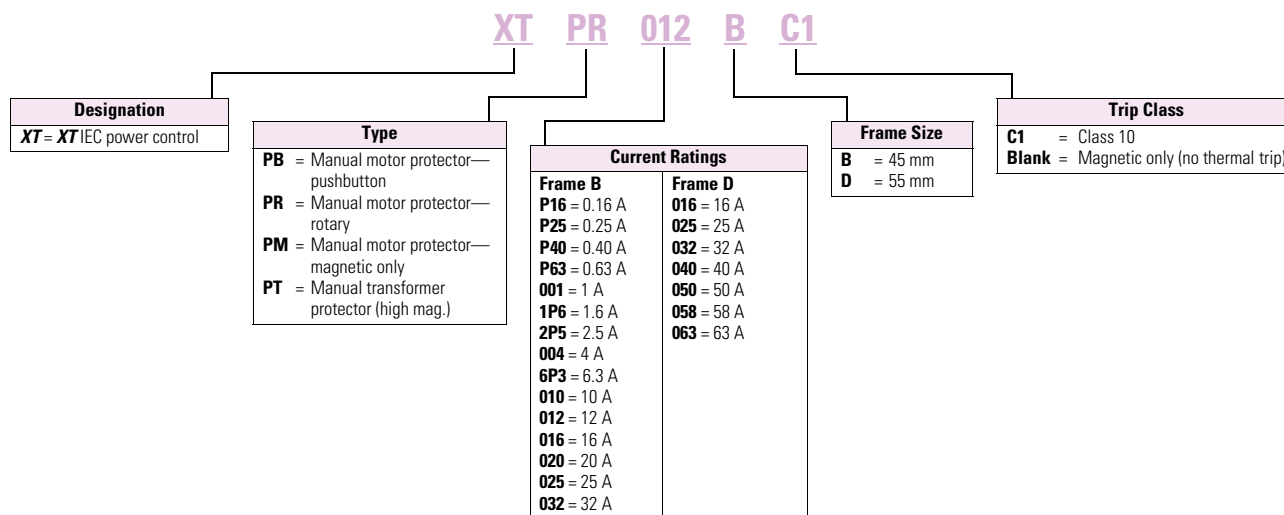

**Reference**

Refer to Tab 1 of this volume, section 1.1 for additional product information.

<b>Manual Motor Protectors</b>	<b>Tab Section</b>
Product Identification . . . . .	1.1
Product Selection . . . . .	1.1
Accessories . . . . .	1.1
Technical Data and Specifications . . . . .	1.1
Dimensions . . . . .	1.1



#### Overload Relays



#### Contents

##### Description

##### Page

Overload Relays	
<i>XT</i> IEC Overload Relays	V5-T5-42
C306 Bimetallic Overload Relays	V5-T5-46
C440/ <i>XT</i> Electronic Overload Relay	V5-T5-47
C441 Overload Relays	V5-T5-68
C445 Motor Management Relay	V5-T5-90

### Product Overview

#### Mini and Thermal Overload Relays

##### *XT* IEC—Miniature

##### Product Description

Eaton's line of *XT* miniature controls includes non-reversing and reversing mini contactors, mini overload relays and snap-on accessories. A wide range of applications is possible, including small electrical motors from fractional to 5 hp (460 Vac) or up to 4 kW (400 Vac).

##### Features

- Phase failure sensitivity
- Direct mount to XTMC and XTMF mini contactors
- Trip Class 10
- 11 settings to cover 0.1 to 12 A
- Ambient temperature compensated -5 to 50 °C [23 to 122 °F]
- Manual and automatic reset by selector switch
- One make (NO) or one break (NC) auxiliary contact as standard
- Test/Off button
- Trip-free release

##### *XT* IEC—Thermal

##### Product Description

The *XT* line of IEC motor thermal overload relays provides an efficient motor protection solution, available up to 630 A. XTOB units can be directly mounted to the contactor or mounted separately.

##### Features

- Direct connect up to 250 A
- Stand alone and CT type up to 630 A
- Large thermal overcurrent range
- Test button
- Manual/automatic selectable reset
- NO-NC auxiliary as standard
- Class 10A (to 250 A)
- Class 30 (CT type)

##### C306—Bimetallic

##### Product Description

C306 Overload Relays are designed for use with CE or CN non-reversing and reversing contactors. Four sizes are available for overload protection up to 144 A.

##### Features

- Selectable manual or automatic reset operation
- Interchangeable heater packs adjustable  $\pm 24\%$  to match motor FLA and calibrated for use with 1.0 and 1.15 service factor motors. Heater packs for 32 A overload relay will mount in 75 A overload relay—useful in derating applications such as jogging
- Class 10 or 20 heater packs
- Load lugs built into relay base
- Bimetallic, ambient compensated operated. Trip free mechanism
- Overload trip indication

**C400 Series Advanced Motor Protection**

Eaton's C400 series of advanced motor protection features three easy-to-use products with varying levels of capability. From basic monitoring and protection to advanced motor management, the C400 series has the exact solution to meet the needs of your application.

**C440 Overload Relay****Product Description**

Compact and fully featured for a basic overload relay—C440 provides a lower cost option for small or less critical motors in motor control centers. It is also ideal for stand-alone panels of any size used in HVAC or commercial applications.

*Range:* 0.3–1500 A  
Up to 690 Vac (50/60 Hz)

**Features**

- Selectable trip class (10A, 10, 20, 30), ground fault and phase imbalance protections
- Flexible communication options for both monitoring and control
- 5:1 FLA range

**Benefits**

- Extends the life of plant assets with selectable motor protection features
- Status LED provides added assurance that valuable assets are protected by indicating the overload operational status
- Industry-leading FLA range reduces part numbers required

**C441 Motor Insight™****Product Description**

The addition of power monitoring and protection detects under-loaded conditions like a dead-headed pump. Combined with a simple user interface for setup and monitoring, C441 is ideal for stand-alone pump or fan panels in industries such as mining and irrigation.

*Range:* 1–540 A  
Up to 600 Vac (50/60 Hz)

**Features**

- Highly configurable line (voltage), load (power) and motor (current) monitoring and protection
- Optional remote user interface allows user to configure and monitor without opening a panel door
- All-in-one design reduces inventory costs by covering 1–540 A applications with only two SKU numbers

**Benefits**

- Advanced diagnostics allow for quick and accurate identification of the root source of motor, pump or power quality faults
- Configurable low-power trip capability provides superior protection for smaller motors, slow speed motors and lightly loaded large motors

**Power Xpert™ C445 Motor Management Relay****Product Description**

Advanced motor management, extensive communications and superior diagnostics and protection make C445 ideal for critical motors in motor control centers where uptime is key. An intuitive interface allows users to access C445 safely from outside the MCC door.

*Range:* 0.3–800 A  
Up to 690 Vac (20–80 Hz)  
Up to 4160 Vac w/PTs

**Features**

- Full line, load and motor system coverage using advanced monitoring and protection algorithms
- Easy commissioning and monitoring tools include a remote-mount user interface, free software tool and web pages
- Multiple predefined operating modes with corresponding control station options

**Benefits**

- Extensive current, voltage, power and system operating data plus real-time clock functionality enhances user understanding of their application
- Multiple embedded fieldbus options allow integration into widest range of PLC and DCS control systems without additional modules or supply power
- User interface provides advanced monitoring, parameter setting, fault diagnostics and optional control with no specialty tools or knowledge required
- Motor management relay operation modes reduce control wiring and complexity

#### Miniature Overload Relays



5

### XT IEC Overload Relays

#### Miniature Overload Relays

##### Product Description

Eaton's new line of **XT** miniature controls includes non-reversing and reversing mini contactors, mini overload relays and snap-on accessories. A wide range of applications is possible, including small electrical motors from fractional to 5 hp (460 Vac) or up to 4 kW (400 Vac).

##### Application Description

Due to its compact size, the **XT** line of mini controls is best suited to be applied in light-duty loads, such as hoisting, packaging, material handling, heating, lighting and automation systems. **XT** mini contactors are a particularly compact, economic and environmentally friendly solution wherever control of small motors or loads is required.

##### Features

##### **Mini Overload Relays— Bimetallic Type XTOM**

- Phase failure sensitivity
- Direct mount to XTMC and XTMF mini contactors
- Trip Class 10
- 11 settings to cover 0.1 to 12 A
- Ambient temperature compensated –5 to 50 °C [23 to 122 °F]
- Manual and automatic reset by selector switch
- One make (NO) or one break (NC) auxiliary contact as standard
- Test/Off button
- Trip-free release

### Contents

#### Description

	<i>Page</i>
<b>XT</b> IEC Overload Relays	
Miniature Overload Relays	
Catalog Number Selection	<b>V5-T5-43</b>
Reference	<b>V5-T5-43</b>
 An Eaton Green Solution	
Thermal Overload Relays	<b>V5-T5-44</b>
C306 Bimetallic Overload Relays	<b>V5-T5-46</b>
C440/ <b>XT</b> Electronic Overload Relay	<b>V5-T5-47</b>
C441 Overload Relays	<b>V5-T5-68</b>
C445 Motor Management Relay	<b>V5-T5-90</b>

#### Standards and Certifications

- IEC EN 60947
- CE approved
- UL
- CSA
- CCC
- ATEX



#### Instructional Leaflets

Pub51219	XTMC, XTMF Mini Contactors, XTRM Mini Control Relay and Accessories
Pub51243	XTOM Mini Overload Relays
Pub51206	Mini Reversing Link Kits
MN03402002E	XTOM Mini Overload Relays Installation and User Manual

**Catalog Number Selection**

**XT IEC Miniature Overload Relays**

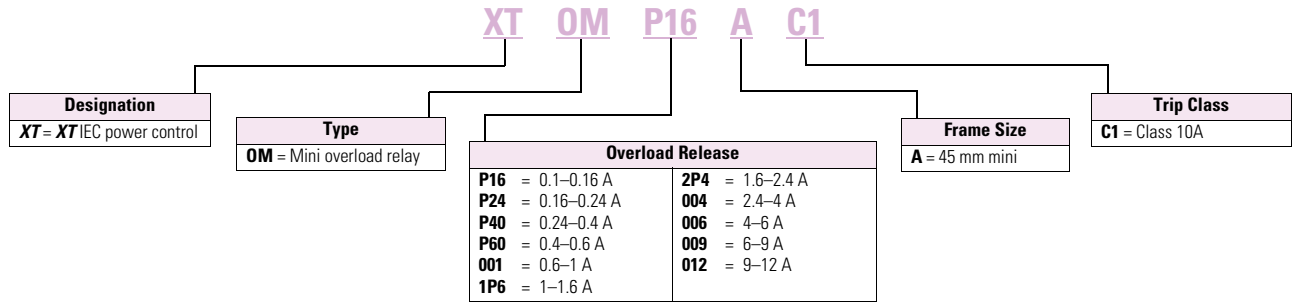

**Mini Overload Relay Settings (A)**

Setting	Starting
<b>A:</b> $I_N \times 0.58$ Motor protection in the Y and delta configurations.	$\leq 15$ sec
<b>B:</b> $I_N \times 1$ Only partial motor protection in star position	15–40 sec
<b>C:</b> $I_N \times 0.58$ Motor not protected in star position.	$> 40$ sec

Timing relay set to approximately 10 sec.

**Note**

Depending on the coordination type required (that is, Type 1 or Type 2) it must be established whether the fuse protection and the input wiring for the main and delta contactors are to be common or separate.

**Reference**

Refer to Tab 1 of this volume, section 1.1 for additional product information.

<b>Miniature Overload Relays</b>	<b>Tab Section</b>
Product Selection . . . . .	<b>1.1</b>
Accessories . . . . .	<b>1.1</b>
Technical Data and Specifications . . . . .	<b>1.1</b>
Wiring Diagrams . . . . .	<b>1.1</b>
Dimensions . . . . .	<b>1.1</b>

#### Thermal Overload Relays



5

#### Contents

##### Description

	<i>Page</i>
<b>XT</b> IEC Overload Relays	
Miniature Overload Relays . . . . .	<b>V5-T5-42</b>
Thermal Overload Relays	
Catalog Number Selection . . . . .	<b>V5-T5-45</b>
Reference . . . . .	<b>V5-T5-45</b>
C306 Bimetallic Overload Relays . . . . .	<b>V5-T5-46</b>
C440/ <b>XT</b> Electronic Overload Relay . . . . .	<b>V5-T5-47</b>
C441 Overload Relays . . . . .	<b>V5-T5-68</b>
C445 Motor Management Relay . . . . .	<b>V5-T5-90</b>

#### Thermal Overload Relays

##### Product Description

The **XT** line of IEC motor thermal overload relays provides an efficient motor protection solution, available up to 630 A. XTOB units can be directly mounted to the contactor or mounted separately.

##### Features and Benefits

- Direct connect up to 250 A
- Stand alone and CT type up to 630 A
- Large thermal overcurrent range
- Test button
- Manual/automatic selectable reset
- NO-NC auxiliary as standard
- Class 10A (to 250 A)
- Class 30 (CT type)

##### Standards and Certifications

- IEC EN 60947
- CE approved
- UL
- CSA
- ATEX
- RoHS



##### Instructional Leaflets

- Pub51221 XTOB, D Frame overload relays (inside of packaging)
- Pub51222 XTOB, B-C Frame overload relays (inside of packaging)

##### Notes

Short-circuit protection: Observe the maximum permissible fuse of the contactor with direct device mounting. See MN03402001E for more information on overload relays for Frames B-G. Trip Class: 10A  
 Suitable for protection of EEx e-motors. EC prototype test certificate available upon request. See manuals MN03402001E and MN03407001E, Page 135.

Catalog Number Selection

XT IEC Overload Relays

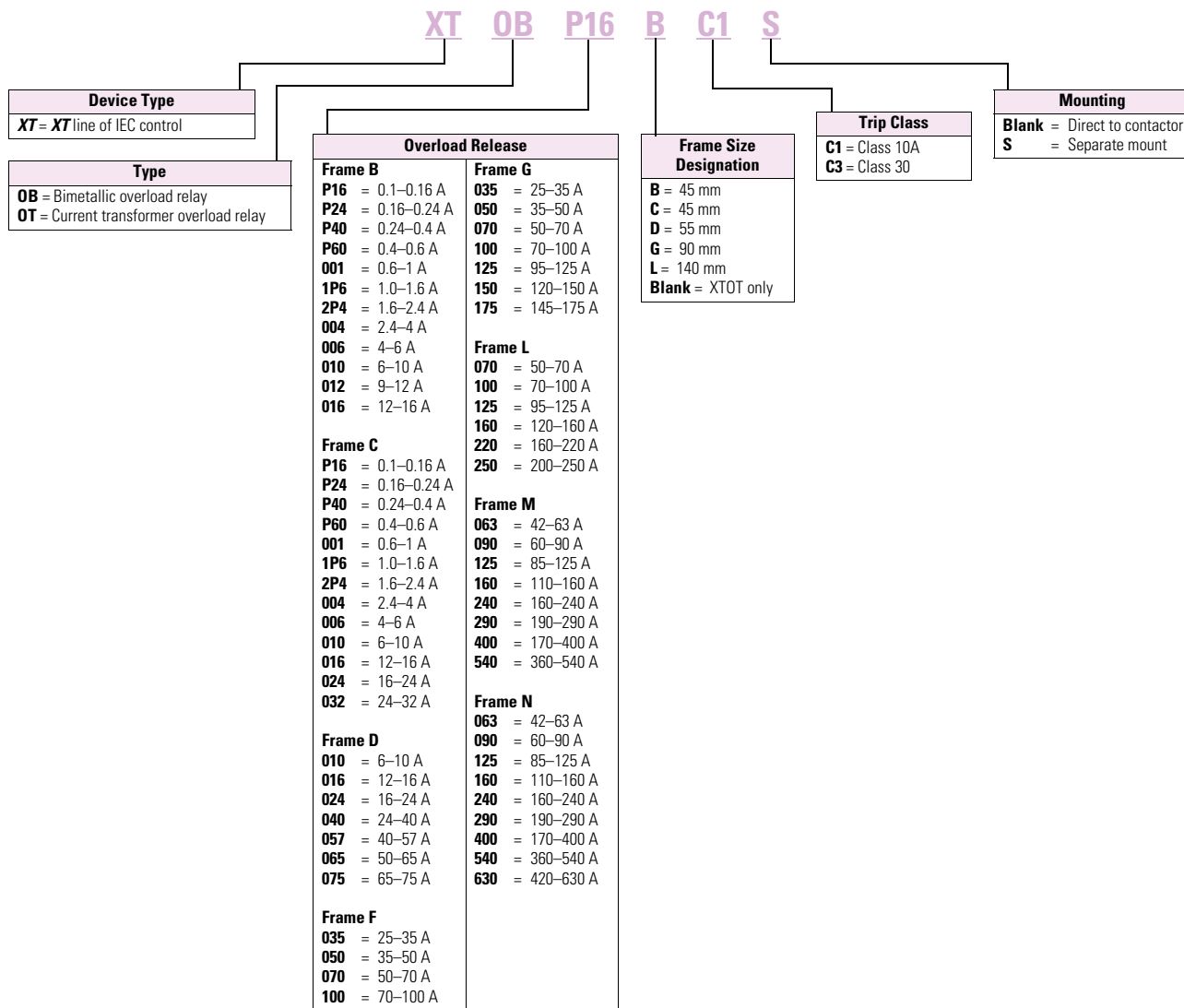

Reference

Refer to Tab 1 of this volume, section 1.1 for additional product information.

Thermal Overload Relays

Tab Section

Product Selection . . . . .	1.1
Accessories . . . . .	1.1
Technical Data and Specifications . . . . .	1.1
Dimensions . . . . .	1.1

32 A Overload—C306DN3B



### Contents

#### Description

<i>Description</i>	<i>Page</i>
<b>XT</b> IEC Overload Relays .....	<b>V5-T5-42</b>
C306 Bimetallic Overload Relays .....	<b>V5-T5-46</b>
C440/ <b>XT</b> Electronic Overload Relay .....	<b>V5-T5-47</b>
C441 Overload Relays .....	<b>V5-T5-68</b>
C445 Motor Management Relay .....	<b>V5-T5-90</b>

### C306 Bimetallic Overload Relays

#### Product Description

C306 Overload Relays are designed for use with CE or CN non-reversing and reversing contactors. Four sizes are available for overload protection up to 144 A.

#### Features

- Selectable manual or automatic reset operation
- Interchangeable heater packs adjustable  $\pm 24\%$  to match motor FLA and calibrated for use with 1.0 and 1.15 service factor motors. Heater packs for 32 A overload relay will mount in 75 A overload relay—useful in derating applications such as jogging
- Class 10 or 20 heater packs
- Load lugs built into relay base
- Bimetallic, ambient compensated operated. Trip free mechanism
- Electrically isolated NO-NC contacts (pull RESET button to test). (Electrical ratings see tables in Tab 2 of this volume, section 2.1)
- Overload trip indication
- Shrouded or fingerproof terminals to reduce possibility of electrical shock

#### Standards and Certifications

- Meets UL 508 single-phasing requirements
- UL listed, CSA certified and NEMA compliance



#### Reference

Refer to Tab 2 of this volume, section 2.1 for additional product information.

<b>C306 Bimetallic Overload Relays</b>	<b>Tab Section</b>
Product Selection .....	<b>2.1</b>
Accessories .....	<b>2.1</b>
Modifications .....	<b>2.1</b>
Replacement Parts .....	<b>2.1</b>
Technical Data and Specifications .....	<b>2.1</b>
Dimensions .....	<b>2.1</b>

C440/XT Electronic Overload Relay



**Contents**

<b>Description</b>	<b>Page</b>
<b>XT</b> IEC Overload Relays .....	<b>V5-T5-42</b>
C306 Bimetallic Overload Relays .....	<b>V5-T5-46</b>
C440/ <b>XT</b> Electronic Overload Relay	
Standards and Certifications .....	<b>V5-T5-48</b>
Catalog Number Selection .....	<b>V5-T5-49</b>
Product Selection .....	<b>V5-T5-51</b>
Accessories .....	<b>V5-T5-56</b>
Technical Data and Specifications .....	<b>V5-T5-58</b>
Dimensions .....	<b>V5-T5-64</b>
C441 Overload Relays .....	<b>V5-T5-68</b>
C445 Motor Management Relay .....	<b>V5-T5-90</b>

**C440/XT Electronic Overload Relay**

**Product Description**

Eaton’s C440/**XT** electronic overload relay is the most compact, high-featured, economical product in its class. Designed on a global platform, it covers the entire power control spectrum including NEMA, IEC and DP contactors. The NEMA and DP versions are offered with the *C440* designation while the IEC offering has the **XT** designation. The electronic design provides reliable, accurate and value driven protection and communications capabilities in a single compact device. It is the flexible choice for any application requiring easy-to-use, reliable protection.

C440 is a self-powered electronic overload relay available up to 175 A as a self contained unit. With external CTs, C440 can protect motor up to 1500 FLA. Available add-on accessories include remote reset capability and communication modules for Modbus RTU, DeviceNet, PROFIBUS, Modbus TCP, EtherNet/IP and HTTP web services all with I/O options.

**Features and Benefits**

**Features**

- Reliable, accurate, electronic motor protection
- Easy to select, install and maintain
- Compact size
- Flexible, intelligent design
- Global product offering—available with NEMA, IEC and DP power control

**Size/Range**

- Broad FLA range (0.33–1500 A)
- Selectable trip class (10A, 10, 20, 30)
- Direct mounting to NEMA, IEC and DP contactors
- Most compact electronic overload in its class

**Motor Control**

- Two B600 alarm (NO) and fault (NC) contacts
- Test/Trip button

**Motor Protection**

- Thermal overload
- Phase loss
- Selectable (ON/OFF) phase imbalance
- Selectable (ON/OFF) ground fault

**User Interface**

- Large FLA selection dial
- Trip status indicator
- Operating mode LED
- DIP switch selectable trip class, phase imbalance and ground fault
- Selectable Auto/Manual reset

**Feature Options**

- Remote reset
  - 120 Vac
  - 24 Vac
  - 24 Vdc
- Tamper-proof cover
- Communications modules
  - Modbus RTU RS-485
  - DeviceNet with I/O
  - PROFIBUS with I/O
  - Modbus RTU with I/O
  - Ethernet IP with I/O
  - Modbus TCP with I/O



#### Benefits

##### Reliability and Improved Uptime

- C440 provides the users with peace of mind knowing that their assets are protected with the highest level of motor protection and communication capability in its class
- Extends the life of plant assets with selectable motor protection features such as trip class, phase imbalance and ground fault
- Protects against unnecessary downtime by discovering changes in your system (line/load) with remote monitoring capabilities
- Status LED provides added assurance that valuable assets are protected by indicating the overload operational status

##### Flexibility

- Available with NEMA, IEC and DP contactors
- Improves return on investment by reducing inventory carrying costs with wide FLA adjustment (5:1) and selectable trip class
- Design incorporates built-in ground fault protection thus eliminating the need for separate CTs and modules
- Flexible communication with optional I/O enables easy integration into plant management systems for remote monitoring and control
- Available as an open component and in enclosed control and motor control center assemblies

##### Monitoring Capabilities

- Individual phase currents RMS
- Average three-phase current RMS
- Thermal memory
- Fault indication (overload, phase loss, phase imbalance, ground fault)

##### Safety

- IP 20 rated terminal blocks
- Available in Eaton's industry leading FlashGard MCCs
- Tested to the highest industry standards such as UL, CSA, CE and IEC
- RoHS compliant

#### Standards and Certifications

- UL
- CSA
- CE
- NEMA
- IEC/EN 60947 VDE 0660
- ISO® 13849-1 (EN954-1)
- RoHS
- ATEX directive 94/9/EC
- Equipment Group 2, Category 2



#### Electronic Overload Education

Description	Definition	Cause	Effect if not Protected	C440/XT Protection
<b>Motor Protection</b>				
Thermal overload	Overload is a condition in which current draw exceeds 115% of the full load amperage rating for an inductive motor.	<ul style="list-style-type: none"> <li>• An increase in the load or torque that is being driven by the motor.</li> <li>• A low voltage supply to the motor causes the current to go high to maintain the power needed.</li> <li>• A poor power factor causing above normal current draw.</li> </ul>	<ul style="list-style-type: none"> <li>• Increase in current draw leads to heat and insulation breakdown, which can cause system failure.</li> <li>• Increase in current can increase power consumption and waste valuable energy.</li> </ul>	<ul style="list-style-type: none"> <li>• Thermal trip behavior is defined by UL, CSA and IEC standards.</li> <li>• Trip class is settable from 10A, 10, 20, 30</li> </ul>
Ground fault	A line to ground fault.	A current leakage path to ground.	An undetected ground fault can burn through multiple insulation windings, ultimately leading to motor failure, not to mention risk to equipment or personnel	Fixed protective setting that takes the starter offline if ground fault current exceeds 50% of the FLA dial setting, that is, if the FLA dial is set to 12A, the overload relay will trip if the ground current exceeds 6A.
Imbalanced phases (voltage and current)	Uneven voltage or current between phases in a three-phase system.	When a three-phase load is powered with a poor quality line, the voltage per phase may be imbalanced.	Imbalanced voltage causes large imbalanced currents and as a result this can lead to motor stator windings being overloaded, causing excessive heating, reduced motor efficiency and reduced insulation life.	Fixed protective setting that takes the starter offline if a phase drops below 50% of the other two phases.
Phase loss—current (single-phasing)	One of the three-phase voltages is not present.	Multiple causes, loose wire, improper wiring, grounded phase, open fuse, and so on.	Single-phasing can lead to unwanted motor vibrations in addition to the results of imbalanced phases as listed above.	Fixed protective setting that takes the starter offline if a phase drops below 50% of the other two phases.

**Catalog Number Selection**

**XT Electronic Overload Relay—IEC ①**

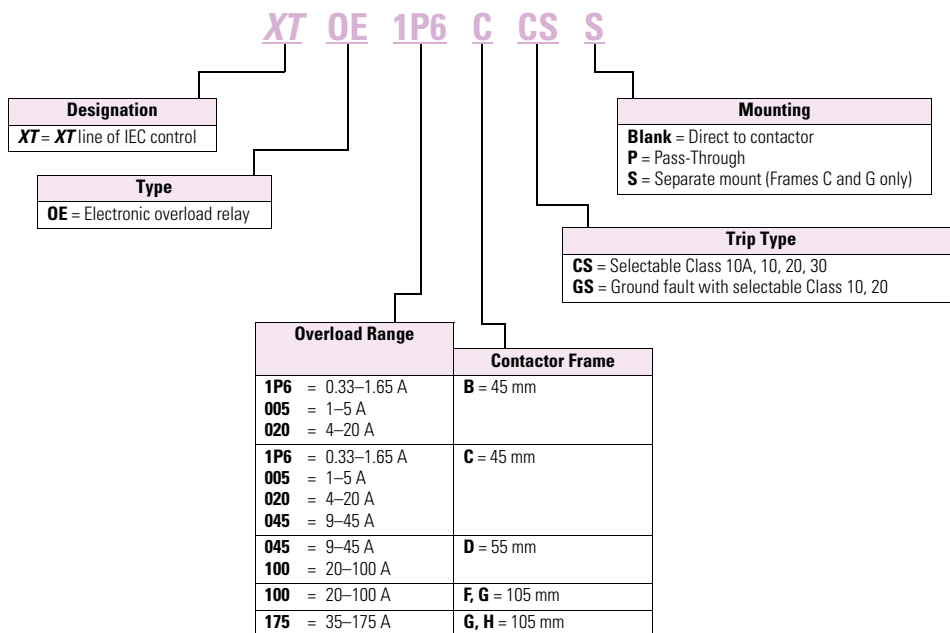

**C440 Electronic Overload Relay—NEMA ②**

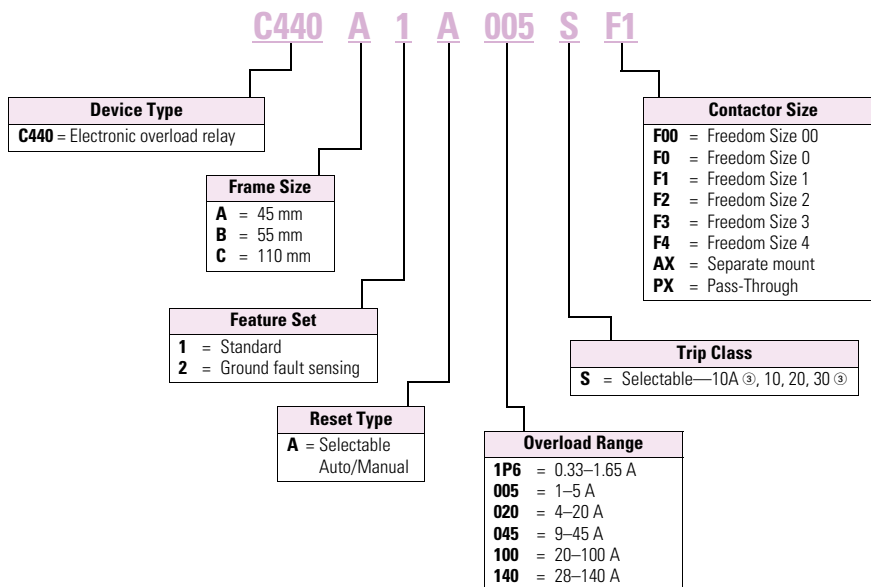

**Notes**

- ① See Page V5-T5-51 for Product Selection.
- ② See Page V5-T5-53 for Product Selection.
- ③ On non-GF version only.

#### Freedom Series NEMA Starters with C440 Electronic Overload Relays <sup>①</sup>

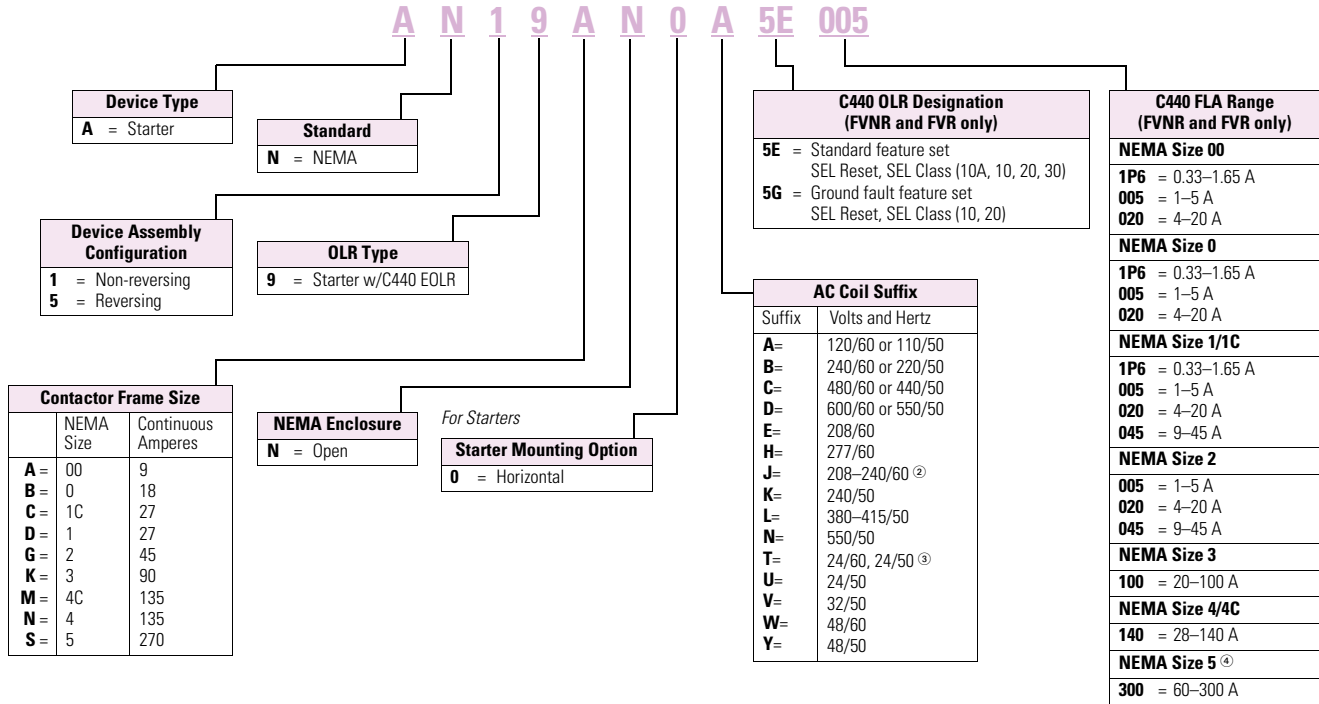

#### Notes

- ① See **Page V5-T5-54** for Product Selection.
- ② NEMA Sizes 00 and 0 only.
- ③ NEMA Sizes 00 and 0 only. Sizes 1–3 are 24/60 only.
- ④ NEMA Size 5 starter available with 60–300 A panel mounted CTs. Starter shipped as an assembled unit with 1–5 A C440 overload relay (C440A1A005SELAX or C440A2A005SELAX).

Product Selection

XT Electronic Overload Relays

45 mm XT for Direct Mount



XT Electronic Overload Relays for Direct Mount to XT Contactors

For Use with XT Contactor Frame	For Use with Contactor	Overload Range (Amps)	Contact Sequence	Frame Size	Auxiliary Contact Configuration	Type	Catalog Number
B	XTCE007B..., XTCE009B..., XTCE012B..., XTCE015B...	0.33–1.65	97 95	45 mm	NO-NC	ZEB12-1,65	<b>XTOE1P6BCS</b>
		1–5				ZEB12-5	<b>XTOE005BCS</b>
		4–20				ZEB12-20	<b>XTOE020BCS</b>
C	XTCE018C..., XTCE025C..., XTCE032C	0.33–1.65	97 95	45 mm	NO-NC	ZEB32-1,65	<b>XTOE1P6CCS</b>
		1–5				ZEB32-5	<b>XTOE005CCS</b>
		4–20				ZEB32-20	<b>XTOE020CCS</b>
		9–45				ZEB32-45	<b>XTOE045CCS</b>
D	XTCE040D..., XTCE050D..., XTCE065D..., XTCE072D...	9–45	97 95	45 mm	NO-NC	ZEB65-45	<b>XTOE045DCS</b>
		20–100		55 mm		ZEB65-100	<b>XTOE100DCS</b>
F	XTCE080F..., XTCE095F..., XTCE115G..., XTCE150G..., XTCE170G...	20–100	97 95	55 mm	NO-NC	ZEB150-100	<b>XTOE100GCS</b>
G	XTCE115G..., XTCE150G..., XTCE170G...	20–100	97 95	55 mm	NO-NC	ZEB150-100	<b>XTOE100GCS</b>
		35–175		110 mm		ZEB150-175	<b>XTOE175GCS</b>
H	XTCE185H...	35–175	2 4 6 98 96	110 mm	NO-NC	ZEB225-175	<b>XTOE175HCS</b>

45 mm XT for Direct Mount with Ground Fault



XT Electronic Overload Relays with Ground Fault for Direct Mount to XT Contactors

For Use with XT Contactor Frame	For Use with Contactor	Overload Range (Amps)	Contact Sequence	Frame Size	Auxiliary Contact Configuration	Type	Catalog Number
B	XTCE007B..., XTCE009B..., XTCE012B..., XTCE015B...	0.33–1.65	97 95	45 mm	NO-NC	ZEB12-1,65-GF	<b>XTOE1P6BGS</b>
		1–5				ZEB12-5-GF	<b>XTOE005BGS</b>
		4–20				ZEB12-20-GF	<b>XTOE020BGS</b>
C	XTCE018C..., XTCE025C..., XTCE032C	0.33–1.65	97 95	45 mm	NO-NC	ZEB32-1,65-GF	<b>XTOE1P6CGS</b>
		1–5				ZEB32-5-GF	<b>XTOE005CGS</b>
		4–20				ZEB32-20-GF	<b>XTOE020CGS</b>
		9–45				ZEB32-45-GF	<b>XTOE045CGS</b>
D	XTCE040D..., XTCE050D..., XTCE065D..., XTCE072D...	9–45	97 95	45 mm	NO-NC	ZEB65-45-GF	<b>XTOE045DGS</b>
		20–100		55 mm		ZEB65-100-GF	<b>XTOE100DGS</b>
F	XTCE080F..., XTCE095F..., XTCE115G..., XTCE150G..., XTCE170G...	20–100	97 95	55 mm	NO-NC	ZEB150-100-GF	<b>XTOE100GGS</b>
G	XTCE115G..., XTCE150G..., XTCE170G...	20–100	97 95	55 mm	NO-NC	ZEB150-100-GF	<b>XTOE100GGS</b>
		35–175		110 mm		ZEB150-175-GF	<b>XTOE175GGS</b>
H	XTCE185H...	35–175	2 4 6 98 96	110 mm	NO-NC	ZEB225-175-GF	<b>XTOE175HGS</b>

# 5.4

## Motor Protection and Monitoring

### Overload Relays

1–6 A OL with CTs



#### XT Electronic Overload Relays for use with Large Frame XT Contactors (L–R) <sup>①</sup>

Use CTs and 1–5 A XT overload relay. CT kit does not include overload relay (order separately).

XT Contactor Frame	For Use with IEC Contactor Amp Range (AC-3)	CT Range (Amps)	Description	CT Kit Catalog Number	Terminal Size	Overload Relay Catalog Number
L, M	185–500 A	60-300	300: 5 panel-mount CT kit with integrated lugs	ZEB-XCT300	750 kcmil (2) 250 kcmil 3/0 Cu/Al	XTOE005CCSS
M, N	300–820 A	120-600	600: 5 panel-mount CT kit with integrated, pass through holes	ZEB-XCT600	(2) 750 kcmil 3/0 Cu/Al	XTOE005CCSS
N	580–1000 A	200-1000	1000: 5 panel-mount CT kit with integrated, pass through holes	ZEB-XCT1000	(3) 750 kcmil 3/0 Cu/Al	XTOE005CCSS
R	1600 A	300-1500	1500: 5 panel-mount CT kit with integrated, pass through holes	ZEB-XCT1500	(4) 750 kcmil 1/0 Cu/Al	XTOE005CCSS

5

45 mm XT for Separate Mount



#### XT Electronic Overload Relays for Separate Mount

Overload Range (Amps)	Frame Size	Contact Sequence	Type	Overload Relay Catalog Number	Overload Relay with Ground Fault Catalog Number
0.33–1.65	45 mm	1 3 5 97 95	ZEB32-1.65/KK	XTOE1P6CCSS	XTOE1P6CGSS
1–5			ZEB32-5/KK	XTOE005CCSS	XTOE005CGSS
4–20		2 4 6 98 96	ZEB32-20/KK	XTOE020CCSS	XTOE020CGSS
9–45			ZEB32-45/KK	XTOE045CCSS	XTOE045CGSS
20–100	55 mm		ZEB150-100/KK	XTOE100GCSS	XTOE100GGSS
35–175	110 mm		ZEB150-175/KK	XTOE175GCSS	XTOE175GGSS

#### XT Electronic Overload Relay for Pass-Through Design

Pass-through design does not include any lugs to land wires. Terminate motor leads directly on contactor.

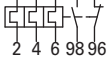
Overload Range (Amps)	Frame Size	Contact Sequence	Type	Overload Relay Catalog Number	Overload Relay with Ground Fault Catalog Number
35–175	110 mm	1 3 5 97 95  2 4 6 98 96	ZEB150-175/PT	XTOE175GCSP	XTOE175GGSP

**C440 Electronic Overload Relays**

45 mm C440 for Direct Mount



**C440 Electronic Overload Relays for Direct Mount to Freedom Series Contactors**

For Use with Freedom NEMA Contactor Size	For Use with Contactor ①	Overload Range (Amps)	Standard Feature Set Catalog Number	Standard Feature Set with Ground Fault Catalog Number
00	CN15AN3_B	0.33–1.65	C440A1A1P6SF00	C440A2A1P6SF00
		1–5	C440A1A005SF00	C440A2A005SF00
		4–20	C440A1A020SF00	C440A2A020SF00
0	CN15BN3_B	0.33–1.65	C440A1A1P6SF0	C440A2A1P6SF0
		1–5	C440A1A005SF0	C440A2A005SF0
		4–20	C440A1A020SF0	C440A2A020SF0
1	CN15DN3_B	0.33–1.65	C440A1A1P6SF1	C440A2A1P6SF1
		1–5	C440A1A005SF1	C440A2A005SF1
		4–20	C440A1A020SF1	C440A2A020SF1
		9–45	C440A1A045SF1	C440A2A045SF1
2	CN15GN3_B	1–5	C440A1A005SF2	C440A2A005SF2
		4–20	C440A1A020SF2	C440A2A020SF2
		9–45	C440A1A045SF2	C440A2A045SF2
3	CN15KN3_	20–100	C440B1A100SF3	C440B2A100SF3
4	CN15NN3_	28–140	C440C1A140SF4	C440C2A140SF4

1–5 A OL with CTs



**C440 Electronic Overload Relays for use with NEMA Contactors Sizes 5–8**

Use CTs and 1–5 A C440 overload relay. CT kit does not include overload relay (order separately).

For Use with NEMA Contactor Size	CT Range (Amps)	Description	CT Kit Catalog Number ②	Terminal Size	Overload Relay Catalog Number
5	60–300	300: 5 panel-mount CT kit with integrated, pass through holes	ZEB-XCT300	750 kcmil (2) 250 kcmil 3/0 Cu/Al	C440A1A005SAX
6	120–600	600: 5 panel-mount CT kit with integrated, pass through holes	ZEB-XCT600	(2) 750 kcmil 3/0 Cu/Al	C440A1A005SAX
7	200–1000	1000: 5 panel-mount CT kit with integrated, pass through holes	ZEB-XCT1000	(3) 750 kcmil 3/0 Cu/Al	C440A1A005SAX
8	300–1500	1500: 5 panel-mount CT kit with integrated, pass through holes	ZEB-XCT1500	(4) 750 kcmil 1/0 Cu/Al	C440A1A005SAX

45 mm C440 for Separate Mount



**C440 Electronic Overload Relays for Separate Mount**

Overload Range	Frame Size	Overload Relay Catalog Number	Overload Relay with Ground Fault Catalog Number
0.33–1.65	45 mm	C440A1A1P6SAX	C440A2A1P6SAX
1–5		C440A1A005SAX	C440A2A005SAX
4–20		C440A1A020SAX	C440A2A020SAX
9–45		C440A1A045SAX	C440A2A045SAX
20–100	55 mm	C440B1A100SAX	C440B2A100SAX
28–140	110 mm	C440C1A140SAX	C440C2A140SAX

**C440 Electronic Overload Relays for Pass-Through Design**

Overload Range	Frame Size	Overload Relay Catalog Number	Overload Relay with Ground Fault Catalog Number
28–140	110 mm	C440C1A140SPX	C440C2A140SPX
35–175		XTOE175GCSP	XTOE175GGSP

**Notes**

- ① CN15 contactor listed is non-reversing with a 120 Vac coil. For more options, see Tab 2 in this volume, section 2.1.
- ② ZEB kits are not recommended for use with C440 overload relays with ground fault option.

#### Type AN19/59 Freedom Series Starters

#### Type AN19/59 Freedom Series Starters with C440 Electronic Overload Relays

##### NEMA Starter



#### Non-Reversing and Reversing

NEMA Size	Continuous Ampere Rating	Service Limit Current Rating (Amps)	Maximum UL Horsepower						Three-Pole Non-Reversing <sup>①②</sup> Catalog Number	Three-Pole Reversing <sup>①②</sup> Catalog Number
			Single-Phase		Three-Phase		480 V	600 V		
			115 V	230 V	208 V	240 V				
00	9	11	1/3	1	1-1/2	1-1/2	2	2	AN19AN0_5E_	AN59AN0_5E_
0	18	21	1	2	3	3	5	5	AN19BN0_5E_	AN59BN0_5E_
1	27	32	2	3	7-1/2	7-1/2	10	10	AN19DN0_5E_	AN59DN0_5E_
2	45	52	3	7-1/2	10	15	25	25	AN19GN0_5E_	AN59GN0_5E_
3	90	104	—	—	25	30	50	50	AN19KN0_5E_	AN59KN0_5E_
4	135	156	—	—	40	50	100	100	AN19NN0_5E_	AN59NN0_5E_
5 <sup>③</sup>	270	311	—	—	75	100	200	200	AN19SN0_5E_	AN59SN0_5E_

#### Type AN19/59 Freedom Series Starters with C440 with Ground Fault Electronic Overload Relays

##### NEMA Starter with Ground Fault



#### Non-Reversing and Reversing

NEMA Size	Continuous Ampere Rating	Service Limit Current Rating (Amps)	Maximum UL Horsepower						Three-Pole Non-Reversing <sup>①②</sup> Catalog Number	Three-Pole Reversing <sup>①②</sup> Catalog Number
			Single-Phase		Three-Phase		480 V	600 V		
			115 V	230 V	208 V	240 V				
00	9	11	1/3	1	1-1/2	1-1/2	2	2	AN19AN0_5G_	AN59AN0_5G_
0	18	21	1	2	3	3	5	5	AN19BN0_5G_	AN59BN0_5G_
1	27	32	2	3	7-1/2	7-1/2	10	10	AN19DN0_5G_	AN59DN0_5G_
2	45	52	3	7-1/2	10	15	25	25	AN19GN0_5G_	AN59GN0_5G_
3	90	104	—	—	25	30	50	50	AN19KN0_5G_	AN59KN0_5G_
4	135	156	—	—	40	50	100	100	AN19NN0_5G_	AN59NN0_5G_
5 <sup>③</sup>	270	311	—	—	75	100	200	200	AN19SN0_5G_	AN59SN0_5G_

#### Coil Suffix Codes

Suffix	Coil Volts and Hertz	Suffix	Coil Volts and Hertz
A	120/60 or 110/50	L	380–415/50
B	240/60 or 220/50	N	550/50
C	480/60 or 440/50	T	24/60, 24/50
D	600/60 or 550/50	U	24/50
E	208/60	V	32/50
H	277/60	W	48/60
J	208–240/60	Y	48/50
K	240/50		

#### C440 FLA Range (FVNR and FVR Starters Only)

NEMA Size	OLR Code	FLA Range	OLR Code	FLA Rating
00	1P6	0.33–1.65 A	020	4.0–20 A
	005	1.0–5.0 A	—	—
0	1P6	0.33–1.65 A	020	4.0–20 A
	005	1.0–5.0 A	—	—
1	1P6	0.33–1.65 A	020	4.0–20 A
	005	1.0–5.0 A	045	9.0–45 A
2	005	1.0–5.0 A	045	9.0–45 A
	020	4.0–20 A	—	—
3	100	20–100 A	—	—
	140	28–140 A	—	—
4	140	28–140 A	—	—
5 <sup>③</sup>	300	60–300 A	—	—

#### Notes

- ① Underscore ( \_ ) indicates coils suffix required, see Coil Suffix table above.
- ② Underscore ( \_ ) indicates OLR designation required, see C440 FLA Range table above.
- ③ NEMA Size 5 starter available with 60–300 A panel mounted CTs. Starter shipped as an assembled unit with 1–5 A C440 overload relay (C440A1A005SELAX or C440A2A005SELAX).

**Compact NEMA Size 1 and 4 Starters**

**New** Compact NEMA Size 1 and 4 starters—available with electronic overload relay **only**.

**Non-Reversing**

NEMA Size	Continuous Ampere Rating	Service Limit Current Rating (Amps)	Maximum UL Horsepower						Three-Pole Non-Reversing Catalog Number
			Single-Phase		Three-Phase		480 V	600 V	
			115 V	230 V	208 V	240 V			
<b>Standard Fault Overload</b>									
1C	27	32	2	3	7.5	7.5	10	10	AN19CN0_5E_
4C	135	156	—	—	40	50	100	100	AN19MN0_5E_
<b>Ground Fault Overload</b>									
1C	27	32	2	3	7.5	7.5	10	10	AN19CN0_5G_
4C	135	156	—	—	40	50	100	100	AN19MN0_5G_

**Electrical Life at Rated Continuous Current**



NEMA Size	Rated Current (Amperage)	
	AC3/AC4	Operations
1C	27/150	2,500,000/40,000
1	27/153	5,000,000/110,000
4C	135/516	500,000/40,000
4	135/822	800,000/70,000



#### Accessories

##### CT Kits

#### Accessories

	Description	Catalog Number
	<b>Safety Cover</b> Clear Lexan cover that mounts on top of the FLA dial and DIP switches when closed.	<b>ZEB-XSC</b>
	<b>Reset Bar</b> Assembles to the top of the overload to provide a larger target area for door mounted reset operators.	<b>ZEB-XRB</b>
	<b>Remote Reset</b> Remote reset module (24 Vdc) ① Remote reset module (120 Vac) ① Remote reset module (24 Vac) ①	<b>C440-XCOM</b> <b>ZEB-XRR-120</b> <b>ZEB-XRR-24</b>

#### Communication

The C440/XTOE is provided with two levels of communication capability.

##### Basic Communication via Expansion Module—Monitoring Only

Basic communication on the C440 is accomplished using an expansion module (C440-XCOM). The expansion module plugs into the expansion bay on the C440 overload relay, enabling communications with the overload via their Modbus RTU (RS-485) network. No additional cards or modules are required. See figure below.



Basic Communication—Modbus

##### Advanced Communication—Monitoring and Control

C440 also has the ability to communicate on industrial protocols such as Modbus RTU, DeviceNet, PROFIBUS, Modbus TCP, and EtherNet/IP while providing control capability using I/O.

An expansion module (C440-XCOM) combined with a communication module allows easy integration onto the customer's network. See figure below.



Advanced Communication—Communication Module

C440 communication modules, wired to the C440-XCOM give C440 control capability via communications. The communication modules offer flexible mounting options (DIN rail or panel) along with four inputs (24 Vdc or 120 Vac) and two outputs as standard.

#### Note

① Customer can wire remote mounted button to reset module (that is, 22 mm pushbutton, catalog number M22-D-B-GB14-K10).

The following information can be viewed using the communication option:

- Motor status—running, stopped, tripped or resetting
- Individual rms phase currents (A, B, C)
- Average of three-phase rms current
- Percent thermal capacity
- Fault codes (only available prior to reset)
- Percent phase unbalance
- Ground fault current and percent
- Overload relay settings—trip class, DIP switch selections, reset selections
- Modbus address (can be set over the network)

### Features and Benefits

#### Ethernet modules

- Single device supports both EtherNet/IP, Modbus TCP
- Internal switch with two Ethernet ports allows linear or ring network configurations
- Embedded web-services for easy configuration and monitoring with Internet Explorer

#### DeviceNet

- I/O assemblies with the same size and layout as the legacy Advantage (WPONIDNA) and **IT** (DSNAP) Starter platforms for seamless upgrades to C441 technology with no program changes
- Communication uses only one DeviceNet MAC ID

#### PROFIBUS

- Capable of baud rates up to 12 Mb
- Intuitive configuration with common PROFIBUS tools

#### Modbus

- Modbus address and baud rate can be changed easily with C441's user interface (C441M only)

#### Terminals

- Unique locking mechanism provides easy removal of terminal block with field wiring installed
- Marked terminals for ease of wiring and troubleshooting

#### On-board I/O assemblies

- Modules offer 4 IN / 2 OUT of network programmable I/O
- 24 Vdc or 120 Vac signal options
- Optical isolation protects the I/O and communication circuits from possible damage due to transients and ground loops
- Inputs feature user-definable debounce, which limits the effects of transients and electrical noise
- Outputs feature a user-definable state for loss of communication: hold last state, ON or OFF

### Communication Accessories

Communication modules mount on their own to be used as stand-alone network based I/O or be wired to the C440-XCOM. Parts are available for purchase individually (see "consists of" below) or as part of a kit for C440 communications.

Description	Catalog Number
-------------	----------------

#### Expansion Module



#### Expansion Module

Expansion module (Remote Reset/Modbus RTU, RS-485 Communication)

**C440-XCOM**

#### Ethernet with I/O Module



#### Communication Modules

DeviceNet communication module kit—120 V I/O (consists of C440-XCOM + C441KS)	<b>C440-DN-120</b>
DeviceNet communication module kit—24 Vdc I/O (consists of C440-XCOM + C441LS)	<b>C440-DN-24</b>
PROFIBUS communication module kit—120 V I/O (consists of C440-XCOM + C441SS)	<b>C440-DP-120</b>
PROFIBUS communication module kit—24 V I/O (consists of C440-XCOM + C441QS)	<b>C440-DP-24</b>
Modbus communication module kit—120 V I/O (consists of C440-XCOM + C441NS)	<b>C440-MOD-120</b>
Modbus communication module kit—24 Vdc I/O (consists of C440-XCOM + C441PS)	<b>C440-MOD-24</b>
Modbus TCP/Ethernet IP communication module kit—120 V I/O (consists of C440-XCOM + C441U)	<b>C440-ET-120</b>
Modbus TCP/Ethernet IP communication module kit—24 V I/O (consists of C440-XCOM + C441V)	<b>C440-ET-24</b>

## Technical Data and Specifications

### Electronic Overload Relays up to 1500 A

Description	Specification		
	45 mm	55 mm	110 mm
<b>Electrical Ratings</b>	<b>Range</b>	<b>Range</b>	<b>Range</b>
Operating voltage (three-phase) and frequency	690 Vac (60/50 Hz)	690 Vac (60/50 Hz)	690 Vac (60/50 Hz)
<b>FLA Range</b>			
	0.33–1.65 A 1–5 A 4–20 A 9–45 A	20–100 A	28–140 A (NEMA) 35–175 A (IEC)
<b>Use with Contactors</b>			
<b>XT</b> IEC frames	B, C, D	F, G	G, H
Freedom NEMA sizes	00, 0, 1, 2	3	4
<b>Trip Class</b>			
	10A, 10, 20, 30 Selectable	10A, 10, 20, 30 Selectable	10A, 10, 20, 30 Selectable
<b>Motor Protection</b>			
Thermal overload setting	1.05 x FLA: does not trip 1.15 x FLA: overload trip	1.05 x FLA: does not trip 1.15 x FLA: overload trip	1.05 x FLA: does not trip 1.15 x FLA: overload trip
<b>Feature</b>	<b>Range</b>	<b>Range</b>	<b>Range</b>
Phase loss	Fixed threshold 50%	Fixed threshold 50%	Fixed threshold 50%
Phase unbalance (selectable: enable/disable)	Fixed threshold 50%	Fixed threshold 50%	Fixed threshold 50%
Ground fault (selectable: enable/disable)	50% of FLA dial setting >150% = 2 sec >250% = 1 sec	50% of FLA dial setting >150% = 2 sec >250% = 1 sec	50% of FLA dial setting >150% = 2 sec >250% = 1 sec
Reset	Manual/automatic	Manual/automatic	Manual/automatic
<b>Indicators</b>			
Trip status	Orange flag	Orange flag	Orange flag
Mode LED	One flash: Overload operating properly Two flashes: Current is above FLA dial setting—pending trip	One flash: Overload operating properly Two flashes: Current is above FLA dial setting—pending trip	One flash: Overload operating properly Two flashes: Current is above FLA dial setting—pending trip
<b>Options</b>			
Remote reset	Yes	Yes	Yes
Reset bar	Yes	Yes	Yes
Communication expansion module	Yes	Yes	Yes
<b>Capacity</b>			
Load terminals			
Terminal capacity	12–10 AWG (4–6 mm <sup>2</sup> ) 8–6 AWG (6–16 mm <sup>2</sup> )	6–1 AWG (16–50 mm <sup>2</sup> )	8–4/0 AWG (10–95 mm <sup>2</sup> )
Tightening torque	20–25 lb-in (2.3–2.8 Nm) 25–30 lb-in (2.8–3.4 Nm)	25–30 lb-in (2.8–3.4 Nm)	124 lb-in (14 Nm)
Input, auxiliary contact and remote reset terminals			
Terminal capacity	2 x (18–12) AWG	2 x (18–12) AWG	2 x (18–12) AWG
Tightening torque	7–11 lb-in (0.8–1.2 Nm)	7–11 lb-in (0.8–1.2 Nm)	7–11 lb-in (0.8–1.2 Nm)
<b>Voltages</b>			
Insulation voltage U <sub>i</sub> (three-phase)	690 Vac	690 Vac	690 Vac
Insulation voltage U <sub>i</sub> (control)	500 Vac	500 Vac	500 Vac
Rated impulse withstand voltage	6000 Vac	6000 Vac	6000 Vac
Overvoltage category/pollution degree	III/3	III/3	III/3

## Electronic Overload Relays up to 1500 A, continued

Description	Specification		
	45 mm	55 mm	110 mm
<b>Auxiliary and Control Circuit Ratings</b>			
Conventional thermal continuous current	5 A	5 A	5 A
Rated operational current—IEC AC-15			
Make contact (1800 VA)			
120 V	15 A	15 A	15 A
240 V	15 A	15 A	15 A
415 V	0.5 A	0.5 A	0.5 A
500 V	0.5 A	0.5 A	0.5 A
Break contact (180 VA)			
120 V	1.5 A	1.5 A	1.5 A
240 V	1.5 A	1.5 A	1.5 A
415 V	0.9 A	0.9 A	0.9 A
500 V	0.8 A	0.8 A	0.8 A
IEC DC-13 (L/R F 15 ms1)			
0–250 V	1.0 A	1.0 A	1.0 A
Rated operational current—UL B600			
Make contact (3600 VA)			
120 V	30 A	30 A	30 A
240 V	15 A	15 A	15 A
480 V	7.5 A	7.5 A	7.5 A
600 V	6 A	6 A	6 A
Break contact (360 VA)			
120 V	3 A	3 A	3 A
240 V	1.5 A	1.5 A	1.5 A
480 V	0.75 A	0.75 A	0.75 A
600 V	0.6 A	0.6 A	0.6 A
R300—Vdc ratings (28 VA)			
0–120 V	0.22 A	0.22 A	0.22 A
250 V	0.11 A	0.11 A	0.11 A
<b>Short-Circuit Rating without Welding</b>			
Maximum fuse	6 A gG/gL	6 A gG/gL	6 A gG/gL
<b>Environmental Ratings</b>			
Ambient temperature (operating)	–13 to 149 °F (–25 to 65 °C)	–13 to 149 °F (–25 to 65 °C)	–13 to 149 °F (–25 to 65 °C)
Ambient temperature (storage)	–40 to 185 °F (–40 to 85 °C)	–40 to 185 °F (–40 to 85 °C)	–40 to 185 °F (–40 to 85 °C)
Operating humidity UL 991 (H3)	5% to 95% non-condensing	5% to 95% non-condensing	5% to 95% non-condensing
Altitude (no derating) NEMA ICS1	2000 m	2000 m	2000 m
Shock (IEC 60068-2-27)	15 g any direction	15 g any direction	15 g any direction
Vibration (IEC 60068-2-6)	3 g any direction	3 g any direction	3 g any direction
Pollution degree per IEC 60947-4-1	3 for product (2 for pcb)	3 for product (2 for pcb)	3 for product (2 for pcb)
Ingress protection	IP20	IP20	IP20
Protection against direct contact when actuated from front (IEC 536)	Finger- and back-of-hand proof	Finger- and back-of-hand proof	Finger- and back-of-hand proof
Mounting position	Any	Any	Any
Climatic proofing	Damp heat, constant to IEC 60068-2-30	Damp heat, constant to IEC 60068-2-30	Damp heat, constant to IEC 60068-2-30

## Electronic Overload Relays up to 1500 A, continued

Description	Specification		
	45 mm	55 mm	110 mm
<b>Electrical/EMC</b>			
Radiated emissions IEC 60947-4-1-Table 15 EN 55011 (CISPR 11) Group 1, Class A, ISM	30 MHz to 1000 MHz	30 MHz to 1000 MHz	30 MHz to 1000 MHz
Conducted emissions IEC 60947-4-1-Table 14 EN 55011 (CISPR 11) Group 1; Class ISM	0.15 MHz to 30 MHz	0.15 MHz to 30 MHz	0.15 MHz to 30 MHz
ESD immunity IEC 60947-4-1 (Table 13)	±8 kV air, ±6 kV contact	±8 kV air, ±6 kV contact	±8 kV air, ±6 kV contact
Radiated immunity IEC 60947-4-1 IEC 61000-4-3	10 V/m 80 MHz–1000 MHz 3 V/m from 1.4 to 2.7 GHz 80% amplitude modulated 1 kHz sine wave	10 V/m 80 MHz–1000 MHz 3 V/m from 1.4 to 2.7 GHz 80% amplitude modulated 1 kHz sine wave	10 V/m 80 MHz–1000 MHz 3 V/m from 1.4 to 2.7 GHz 80% amplitude modulated 1 kHz sine wave
Conducted immunity IEC 60947-4-1, IEC 61000-4-6	140 dub (10 V rms) 150 kHz–100 MHz	140 dub (10 V rms) 150 kHz–100 MHz	140 dub (10 V rms) 150 kHz–100 MHz
Fast transient immunity IEC 60947-4-1 (Table 13) IEC 61000-4-4	±4 kV using direct method with accessory installed in expansion bay ±2 kV using direct method	±4 kV using direct method with accessory installed in expansion bay ±2 kV using direct method	±4 kV using direct method with accessory installed in expansion bay ±2 kV using direct method
Surge immunity IEC 60947-4-1 (Table 13) IEC 61000-4-5 a Class 4	Three-phase power inputs: ±4 kV line-to-line (DM) ±4 kV line-to-ground (CM)  With accessory installed in expansion bay: ±2 kV line-to-line (DM) →1.2/50 us; 2 kV line-to-earth, 1 kV line-to-line ±4 kV line-to-ground (CM)	Three-phase power inputs: ±4 kV line-to-line (DM) ±4 kV line-to-ground (CM)  With accessory installed in expansion bay: ±2 kV line-to-line (DM) →1.2/50 us; 2 kV line-to-earth, 1 kV line-to-line ±4 kV line-to-ground (CM)	Three-phase power inputs: ±4 kV line-to-line (DM) ±4 kV line-to-ground (CM)  With accessory installed in expansion bay: ±2 kV line-to-line (DM) →1.2/50 us; 2 kV line-to-earth, 1 kV line-to-line ±4 kV line-to-ground (CM)
Power freq. magnetic field immunity IEC 60947-4-1, IEC 61000-4-8	30 A/m, 50 Hz	30 A/m, 50 Hz	30 A/m, 50 Hz
Electromagnetic field IEC 60947-4-1 Table 13, IEC 61000-4-3	10 V/m	10 V/m	10 V/m
Distortion IEEE 519	5% THD max., 5th harmonic 3% max.	5% THD max., 5th harmonic 3% max.	5% THD max., 5th harmonic 3% max.
Electrostatic discharge (ESD) IEC 61000-4-2, EN 61131-2	4 kV contact 8 kV air discharge	4 kV contact 8 kV air discharge	4 kV contact 8 kV air discharge
Electrical fast transient (EFT) IEC 61000-4-4, EN 61131-2	±2 kV using direct method	±2 kV using direct method	±2 kV using direct method
Surge immunity IEC 61000-4-5, EN 61131-2	±2 kV line-to-ground (CM)	±2 kV line-to-ground (CM)	±2 kV line-to-ground (CM)

**Communication Modules**

Description	Modbus	DeviceNet	PROFIBUS	Ethernet
<b>Electrical/EMC</b>				
Radiated emissions IEC 60947-4-1—Table 15, EN 55011 (CISPR 11) Group 1, Class A	30–1000 MHz	30–1000 MHz	30–1000 MHz	30–1000 MHz
Conducted emissions IEC 60947-4-1—Table 14, EN 55011 (CISPR 11) Group 1, Class A	0.15–30 MHz	0.15–30 MHz	0.15–30 MHz	0.15–30 MHz
ESD immunity IEC 60947-4-1 (Table 13)	±8 kV air, ±4 kV contact	±8 kV air, ±4 kV contact	±8 kV air, ±4 kV contact	±8 kV air, ±4 kV contact
Radiated immunity IEC 60947-4-1	10 V/m 80–1000 MHz 80% amplitude modulated 1 kHz sine wave	10 V/m 80–1000 MHz 80% amplitude modulated 1 kHz sine wave	10 V/m 80–1000 MHz 80% amplitude modulated 1 kHz sine wave	10 V/m 80–1000 MHz 80% amplitude modulated 1 kHz sine wave
Conducted immunity IEC 60947-4-1	140 dBuV (10 V rms) 150 kHz–80 MHz	140 dBuV (10 V rms) 150 kHz–80 MHz	140 dBuV (10 V rms) 150 kHz–80 MHz	140 dBuV (10 V rms) 150 kHz–80 MHz
Fast transient immunity IEC 60947-4-1 (Table 13) IEC 6100-4-4	±2 kV using direct method	±2 kV supply and control, ±1 kV communication	±2 kV supply and control, ±1 kV communication	±2 kV supply and control, ±1 kV communication
Surge immunity IEC 60947-4-1 (Table 13) IEC 61000-4-5 Class 3	User IO and communication lines ①: ±1 kV line-to-line (DM) ±2 kV line-to-ground (CM)	User IO and communication lines: ±0.5 kV line-to-line (DM) ±1 kV line-to-ground (CM)	User IO and communication lines: ±0.5 kV line-to-line (DM) ±1 kV line-to-ground (CM)	User IO and communication lines: ±0.5 kV line-to-line (DM) ±1 kV line-to-ground (CM)
Electromagnetic field ① IEC 60947-4-1 (Table 13) IEC 61000-4-3	10 V/m	10 V/m	10 V/m	10 V/m
<b>Environmental Ratings</b>				
Ambient temperature (operating)	–4 to 122 °F (–20 to 50 °C)	–13 to 122 °F (–25 to 50 °C)	–13 to 122 °F (–25 to 50 °C)	–13 to 122 °F (–25 to 50 °C)
Ambient temperature (storage)	–40 to 185 °F (–40 to 85 °C)	–40 to 185 °F (–40 to 85 °C)	–40 to 185 °F (–40 to 85 °C)	–40 to 185 °F (–40 to 85 °C)
Operating humidity	5–95% noncondensing	5–95% noncondensing	5–95% noncondensing	5–95% noncondensing
Altitude (no derating)	2000 m	2000 m	2000 m	2000 m
Shock (IEC 600068-2-27)	15 G any direction	15 G any direction	15 G any direction	15 G any direction
Vibration (IEC 60068-2-6)	3 G any direction	3 G any direction	3 G any direction	3 G any direction
Pollution degree per IEC 60947-1	3	3	3	3
Degree of protection	IP20	IP20	IP20	IP20
Overvoltage category per UL 508	III	III	III	III
<b>DeviceNet</b>				
DeviceNet connections	—	Group 2, polling, bit strobe, explicit, no UCMM	—	—
DeviceNet baud rate	—	125 K, 250 K, 500 K	—	—
<b>Ethernet</b>				
Ethernet connections	—	—	—	Integrated two-port switch with dual RJ45 Ethernet connections
Ethernet type	—	—	—	Ethernet 10/100 Mbs, AutoMDX, Auto Negotiation
<b>PROFIBUS</b>				
PROFIBUS connections	—	—	Group 2, polling, bit strobe, explicit, no UCMM	—
PROFIBUS baud rate	—	—	9.6 K, 19.2 K, 45.45 K, 93.75 K, 187.5 K, 500 K, 1.5 M, 3 M, 6 M, 12 M	—

**Note**

① Relates to C441M only.

## Communication Modules, continued

Description	Modbus	DeviceNet	PROFIBUS	Ethernet
<b>C441_ 24 Vdc Input</b>				
Nominal input voltage	24 Vdc	24 Vdc	24 Vdc	24 Vdc
Operating voltage	18–30 Vdc	18–30 Vdc	18–30 Vdc	18–30 Vdc
Number of inputs	4	4	4	4
Signal delay	5 ms (programmable to 65 sec)	5 ms (programmable to 65 sec)	5 ms (programmable to 65 sec)	5 ms (programmable to 65 sec)
OFF-state voltage	<6 Vdc	<6 Vdc	<6 Vdc	<6 Vdc
ON-state voltage	>18 Vdc	>18 Vdc	>10 Vdc	>18 Vdc
Nominal input current	5 mA	5 mA	5 mA	5 mA
Isolation	1500 V	1500 V	1500 V	1500 V
Terminal screw torque	7–9 in-lb	7–9 in-lb	7–9 in-lb	7–9 in-lb
24 V source current	50 mA	50 mA	50 mA	50 mA
<b>Operating Voltage Range—DC Input Modules</b>				
OFF state	0–6 Vdc	0–6 Vdc	0–6 Vdc	0–6 Vdc
Transition region	6–18 Vdc	6–18 Vdc	6–18 Vdc	6–18 Vdc
ON state	18–30 Vdc	18–30 Vdc	18–30 Vdc	18–30 Vdc
<b>C441_ 120 Vac Input</b>				
Nominal input voltage	120 Vac	120 Vac	120 Vac	120 Vac
Operating voltage	80–140 Vac	80–140 Vac	80–140 Vac	80–140 Vac
Number of inputs	4	4	4	4
OFF-state voltage	<30 Vac	<30 Vac	<20 Vac	<30 Vac
ON-state voltage	>80 Vac	>80 Vac	>70 Vac	>80 Vac
Nominal input current	15 mA	15 mA	15 mA	15 mA
Signal delay	1/2 cycle	1/2 cycle	1/2 cycle	1/2 cycle
Isolation	1500 V	1500 V	1500 V	1500 V
Terminal screw torque	7–9 in-lb	7–9 in-lb	7–9 in-lb	7–9 in-lb
<b>Operating Voltage Range—AC Input Modules</b>				
OFF state	0–30 Vac	0–30 Vac	0–30 Vac	0–30 Vac
Transition region	30–80 Vac	30–80 Vac	30–80 Vac	30–80 Vac
ON state	80–140 Vac	80–140 Vac	80–140 Vac	80–140 Vac
<b>Output Modules</b>				
Nominal voltage	120 Vac 24 Vdc	120 Vac 24 Vdc	120 Vac 24 Vdc	120 Vac 24 Vdc
Number of outputs	(2) 1NO Form A 1NO/NC Form C	(2) 1NO Form A 1NO/NC Form C	(2) 1NO Form A 1NO/NC Form C	(2) 1NO Form A 1NO/NC Form C
Relay OFF time	3 ms	3 ms	3 ms	3 ms
Relay ON time	7 ms	7 ms	7 ms	7 ms
Max. current per point <sup>①</sup>	5 A (B300 rated)	5 A (B300 rated)	5 A (B300 rated)	5 A (B300 rated)
Electrical life	100,000 cycles	100,000 cycles	100,000 cycles	100,000 cycles
Mechanical life	1,000,000 cycles	1,000,000 cycles	1,000,000 cycles	1,000,000 cycles

**Note**

<sup>①</sup> Resistive current at 55 °C ambient.

**Short Circuit Ratings (North America CSA, cUL)**

Changes to UL 508A and NEC in recent years have brought a focus to control panel safety with regard to short-circuit current ratings (SCCR). Eaton’s C440 electronic overload relays combined with **XT** series IEC and Freedom Series NEMA contactors provide a wide variety of SCCR solutions needed for a variety of applications. The SCCR data in this document reflects the latest information as of April 2010.

**C440/XT Standalone Overload Relays (XT, C440)**

Overload FLA Range	Maximum Operating Voltage	Standard-Fault Short Circuit Data			High-Fault Short Circuit Data Fuses (RK5, J, CC)			Thermal-Magnetic Circuit Breakers		
		600 V (kA)	Maximum Fuse Size (A) (RK5)	Maximum Breaker Size (A)	480 V (kA)	600 V (kA)	Maximum Fuse Size	480 V (kA)	600 V (kA)	Maximum Breaker Size
0.33–1.65A	600 Vac	1	6	15	—	—	—	—	—	—
1–5 A	600 Vac	5	20	20	100	100	30	100	35	20
4–20 A	600 Vac	5	80	80	100	100	100	100	35	80
9–45 A	600 Vac	5	175	175	100	100	100	100	35	100/175 (480/600)
20–100 A	600 Vac	10	400	400	100	100	200	150	35	250/400 (480/600)
28–140 A	600 Vac	10	450	500	100	100	400	100	65	400
35–175 A	690 Vac	10	500 (gG)	350 (690 Vac) 320 (415 Vac)	100	100	500 (gG)	100 (415 Vac)	—	350 (LGC3350) 320 (NZMH3)

**NEMA Freedom Series Starters with C440 Electronic Overload Relays**

NEMA Size	Maximum Operating Voltage	High-Fault Short Circuit Data Fuses (RK5, J, CC)		Maximum Fuse Size	Thermal-Magnetic Circuit Breakers		
		480 V	600 V		480 V	600 V	Maximum Breaker Size
00	0.33–1.65 A	100	100	30	—	—	—
	1–5 A	100	100	30	100	35	35
	4–20 A	100	100	30	100	35	35
0	0.33–1.65 A	100	100	60	—	—	—
	1–5 A	100	100	60	100	35	70
	4–20 A	100	100	60	100	35	70
1	0.33–1.65 A	100	100	100	—	—	—
	1–5 A	100	100	100	100	35	100
	4–20 A	100	100	100	100	35	100
	9–45 A	100	100	100	100	35	100
2	1–5 A	100	100	100	100	35	175
	4–20 A	100	100	100	100	35	175
	9–45 A	100	100	100	100	35	175
3	20–100 A	100	100	200	50	50	250
4	28–140 A	100	100	400	100	65	300

**IEC XT Starters with XT Electronic Overload Relays**

Contactor Frame Size	Maximum Operating Voltage	High-Fault Short Circuit Data Fuses (RK5, J, CC)		Maximum Fuse Size	Thermal-Magnetic Circuit Breakers		
		480 V	600 V		480 V	600 V	Maximum Breaker Size
B	1–5 A	100	100	30	—	—	—
	4–20 A	100	100	30	—	—	—
C	1–5 A	100	100	60	—	—	—
	4–20 A	100	100	60	—	—	—
	9–45 A	100	100	60	—	—	—
D	9–45 A	100	100	200	65	35	175
	20–100 A	100	100	200	65	35	175
F	20–100 A	100	100	200	65	65	350
G	20–100 A	100	100	200	65	65	350
	35–175 A	100	100	400	65	30	250 (480 Vac) 350 (600 Vac)
H	35–175 A	100	100	400	65	30	400



# 5.4

## Motor Protection and Monitoring

### Overload Relays

#### Dimensions

Approximate Dimensions in Inches (mm)

#### 45 mm C440/XT Electronic Overload Relays

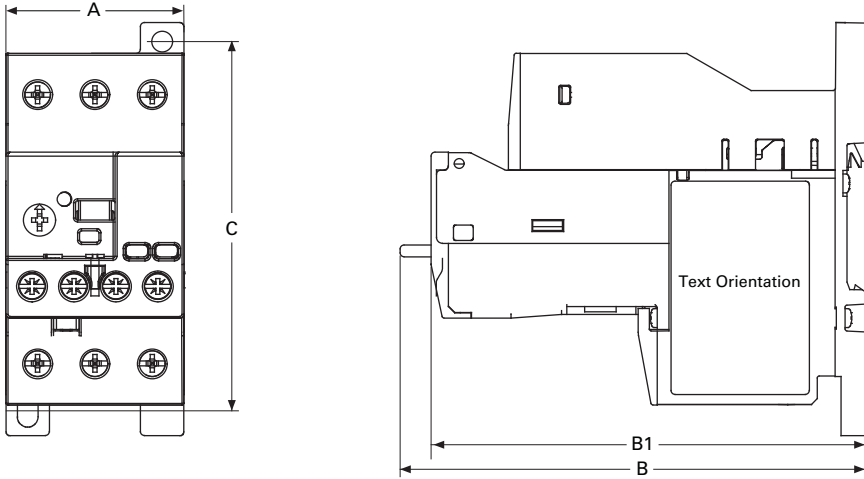

	Width A	Depth B1	Depth to Reset B	Mounting Hole (Height) C
<b>NEMA Starter Size</b>				
00–2	1.80 (45.0)	4.32 (109.7)	4.63 (117.5)	—
<b>XTIEC Frame Size</b>				
B, C, D	1.80 (45.0)	4.32 (109.7)	4.30 (109.2)	—
<b>Standalone</b>				
0.35–45 A	1.80 (45.0)	4.32 (109.7)	4.63 (117.5)	3.68 (93.5)

#### 55 mm C440/XT Electronic Overload Relays

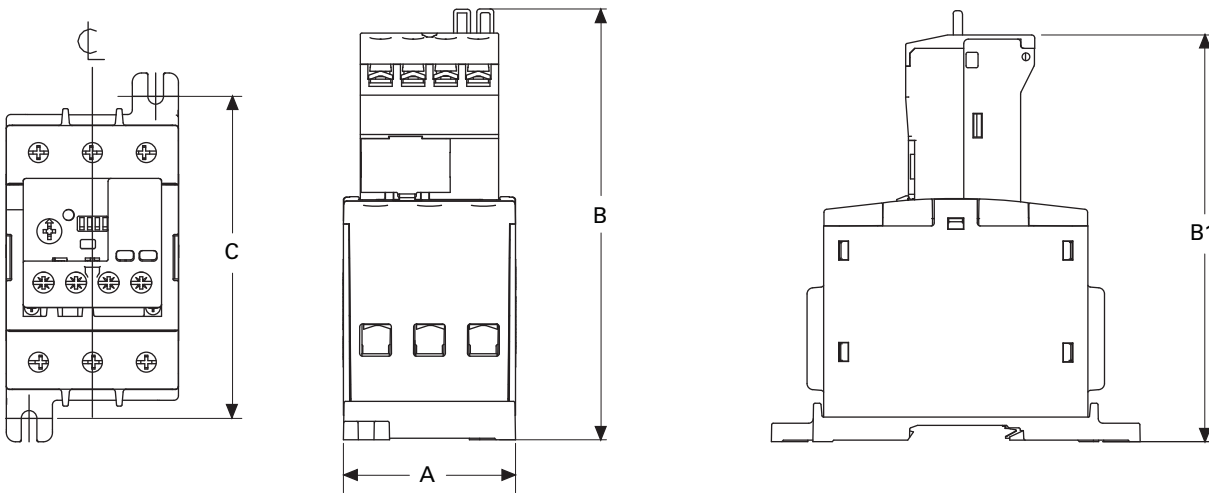

	Width A	Depth to Reset B	Depth B1	Mounting Hole (Height) C
<b>NEMA Starter Size</b>				
3	2.21 (55.0)	5.52 (140.2)	5.21 (132.4)	4.13 (104.8)
<b>XTIEC Frame Size</b>				
D, F, G	2.21 (55.0)	5.52 (140.2)	5.21 (132.4)	4.13 (104.8)
<b>Standalone</b>				
20–100 A	2.21 (55.0)	5.52 (140.2)	5.21 (132.4)	4.13 (104.8)

Approximate Dimensions in Inches (mm)

110 mm C440/XT Electronic Overload Relays

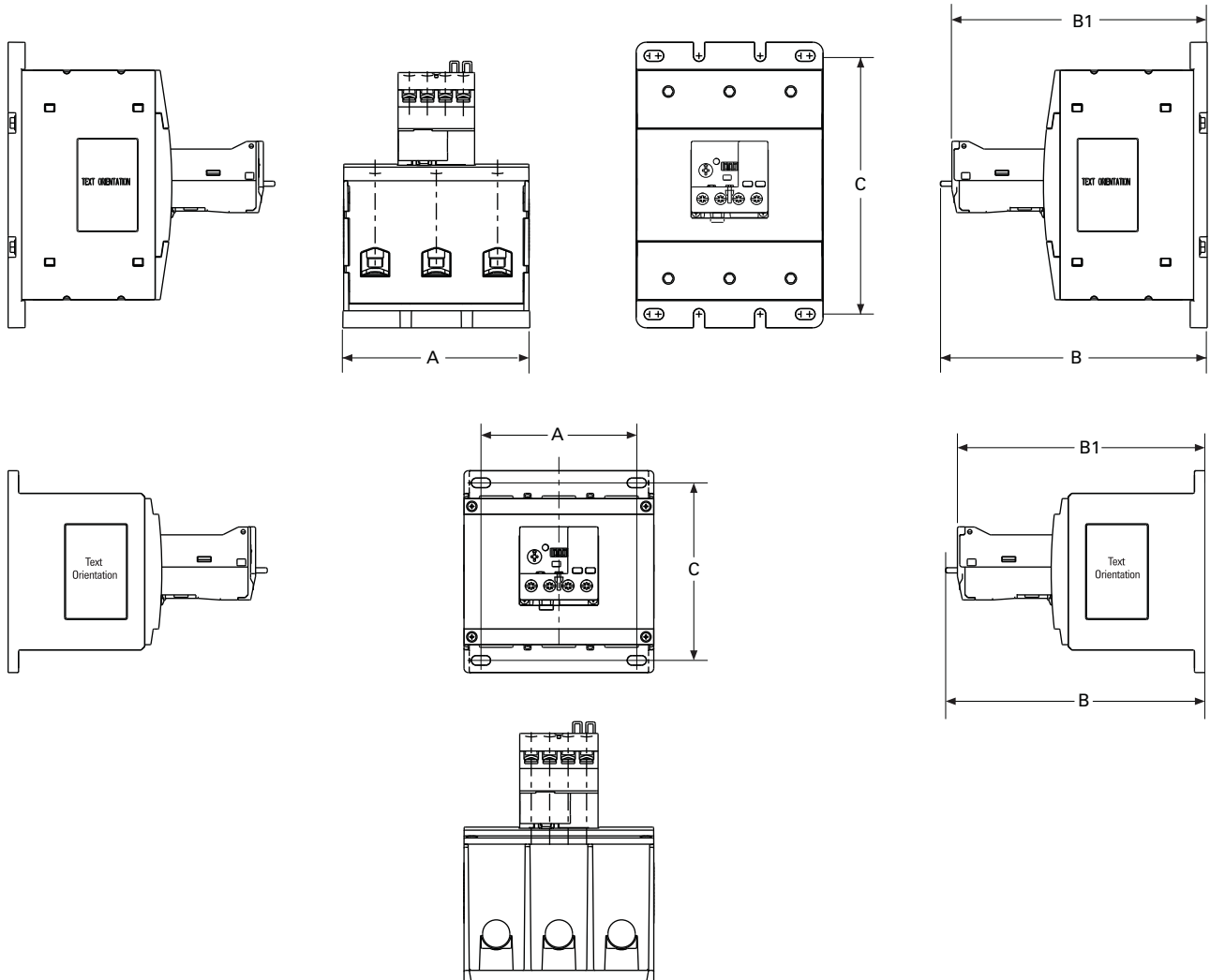

	Width A	Height To Reset B	B1	Mounting Depth C
<b>NEMA Starter Size</b>				
4	4.33 (110.0)	6.20 (157.0)	5.90 (150.0)	6.00 (152.0)
<b>XTIEC Frame Size</b>				
G	4.33 (110.0)	6.20 (157.0)	5.90 (150.0)	6.00 (152.0)
H	4.33 (110.0)	6.20 (157.0)	5.90 (150.0)	6.00 (152.0)
<b>Standalone</b>				
	4.33 (110.0)	6.20 (157.0)	5.90 (150.0)	6.00 (152.0)
<b>Pass-Through</b>				
	4.33 (110.0)	6.20 (157.0)	5.90 (150.0)	6.00 (152.0)

# 5.4

## Motor Protection and Monitoring

### Overload Relays

Approximate Dimensions in Inches (mm)

#### NEMA Starters

#### Full Voltage Non-Reversing Starters

5

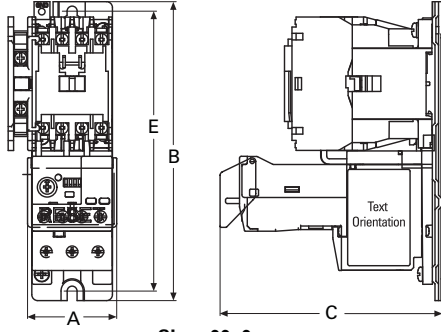

Sizes 00, 0

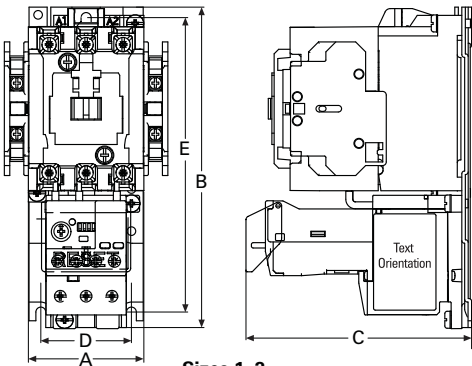

Sizes 1, 2

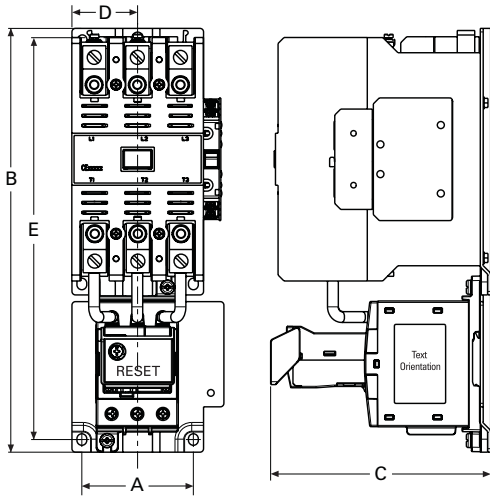

Size 3

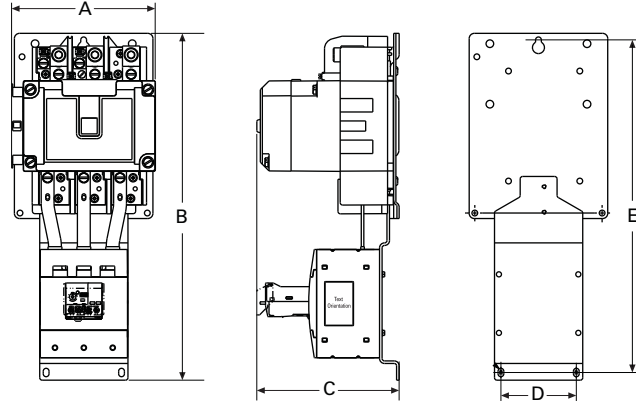

Size 4

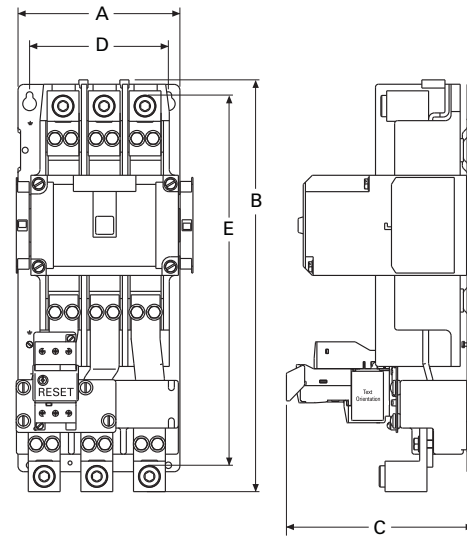

Size 5

NEMA Size	A	B	C	D	E
00, 0	1.97 (50.0)	6.60 (167.6)	4.90 (124.5)	—	6.18 (157.0)
1, 2	2.60 (65.0)	7.10 (180.0)	4.98 (126.5)	2.00 (50.8)	6.50 (165.0)
3	4.09 (103.8)	11.40 (289.6)	5.92 (150.3)	1.77 (44.9)	10.81 (274.6)
4	7.10 (179.0)	17.00 (432.0)	7.00 (177.0)	3.70 (94.0)	16.30 (415.0)
5	7.00 (177.8)	17.81 (452.3)	8.08 (205.2)	6.00 (152.4)	16.01 (406.6)

Approximate Dimensions in Inches (mm)

Full Voltage Reversing Starters

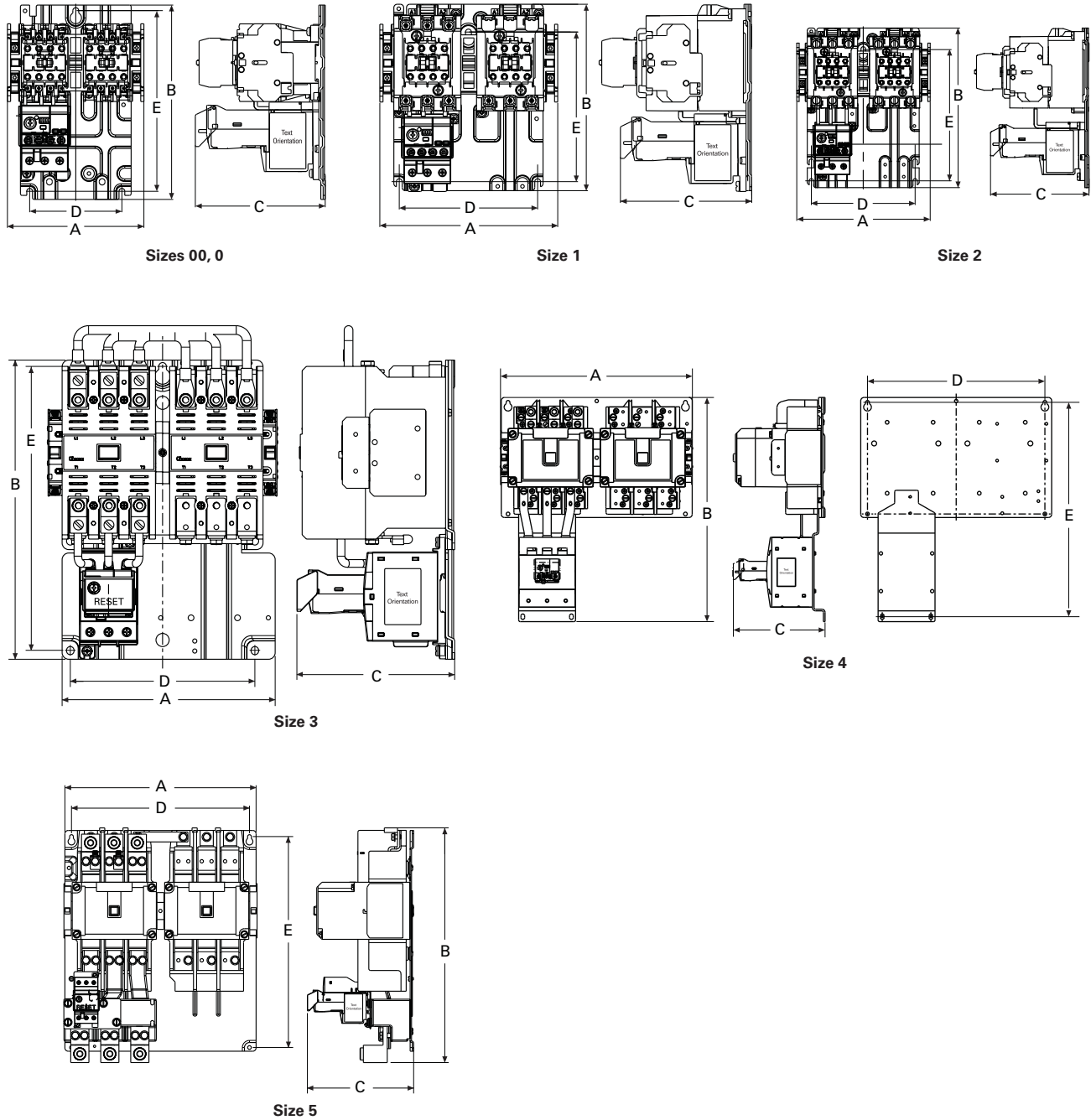

NEMA Size	A	B	C	D	E
00, 0	5.20 (132.0)	7.40 (187.0)	4.90 (125.0)	3.50 (89.0)	6.90 (174.0)
1	6.70 (171.0)	7.10 (180.0)	4.98 (126.5)	5.25 (133.0)	5.70 (144.0)
2	6.70 (171.0)	8.10 (205.0)	4.98 (126.5)	5.25 (133.0)	6.70 (170.0)
3	8.08 (205.2)	11.35 (288.3)	6.00 (152.0)	7.00 (177.8)	10.77 (273.6)
4	14.60 (371.0)	17.10 (433.0)	7.00 (177.0)	13.50 (343.0)	16.30 (415.0)
5	14.50 (368.3)	17.81 (452.3)	8.06 (204.8)	13.50 (342.9)	16.00 (406.6)

Motor Insight Overload and Monitoring Relay



5

### Contents

#### Description

	<i>Page</i>
<b>XT</b> IEC Overload Relays .....	<b>V5-T5-42</b>
C306 Bimetallic Overload Relays .....	<b>V5-T5-46</b>
C440/ <b>XT</b> Electronic Overload Relay .....	<b>V5-T5-47</b>
C441 Overload Relays	
Features and Benefits .....	<b>V5-T5-69</b>
Catalog Number Selection .....	<b>V5-T5-70</b>
Product Selection .....	<b>V5-T5-71</b>
Accessories .....	<b>V5-T5-73</b>
Technical Data and Specifications .....	<b>V5-T5-75</b>
Dimensions .....	<b>V5-T5-87</b>
C445 Motor Management Relay .....	<b>V5-T5-90</b>

### C441 Overload Relays

#### Product Description

Eaton's Motor Insight overload relay offers configurable motor, load and line protection. The addition of power monitoring and protection detects under-loaded conditions like a dead-headed pump. With a simple user interface for setup and monitoring and just two part numbers covering 1–90 A applications, C441 is ideal for stand-alone pump or fan panels used in industries such as mining and irrigation. C441 is also offered in complete pump panel designs as part of Eaton's Enclosed Control offering. See Volume 10—Enclosed Control, CA08100012E, Tab 6 for more information.

Motor Insight is available in either a line-powered or 120 Vac control powered design, capable of monitoring voltages up to 660 Vac. Each of these units is available in a 1–9 amp or a 5–90 amp FLA model. With external CTs, Motor Insight can protect motors up to 540 amps FLA. Available add-on accessories include communication modules for Modbus RTU, DeviceNet, PROFIBUS, Modbus TCP, EtherNet/IP and HTTP web services all with I/O options. For ease-of-use and operator safety, Motor Insight offers a remote display that mounts easily with two 30 mm knockouts.

The Motor Insight family also offers a high voltage relay option, capable of providing overload and current protection on systems up to 1200 Vac.

## Features and Benefits

### Features

#### Size/Range

- Broad FLA range of 1–540 A
- Selectable trip class (5–30)
- Four operating voltage options
  - Line-powered from 240 Vac, 480 Vac, 600 Vac
  - Control-powered from 120 Vac

#### Motor Control

- Two output relays
  - One B300 Form C fault relay and one B300 ground fault shunt relay
  - Other relay configurations are available, including one Form A and one Form B SPST (fault and auxiliary relays) allowing programmable isolated relay behavior and unique voltages
- One external remote reset terminal
- Trip status indicator

#### Motor Protection

- Thermal overload
- Jam protection
- Current imbalance
- Current phase loss
- Ground fault
- Phase reversal

#### Load Protection

- Under current
- Low power (kW)
- High power (kW)

#### Standards and Certifications

- cULus listed NKCR, NKCR7, 508
- UL® 1053 applicable sections for ground fault detection

#### Line Protection

- Over voltage
- Under voltage
- Voltage imbalance
- Voltage phase loss

#### Monitoring Capabilities

- Current—average and phase rms
- Voltage—average and phase rms
- Power—motor kW
- Power factor
- Frequency
- Thermal capacity
- Run hours
- Ground fault current
- Current imbalance %
- Voltage imbalance %
- Motor starts
- Motor run hours

#### Options

- Type 1, 12 remote display
- Type 3R remote display kit
- Communication modules
  - Modbus
  - Modbus with I/O
  - DeviceNet with I/O
  - PROFIBUS with I/O
  - Modbus TCP with I/O
  - EtherNet/IP with I/O

### Benefits

#### Reliability and Improved Uptime

- Advanced diagnostics allows for quick and accurate identification of the root source of a motor, pump or power quality fault; reducing troubleshooting time and the loss of productivity, reducing repeat faults due to misdiagnosis, and increasing process output and profitability
- Provides superior protection of motors and pumps before catastrophic failure occurs
- Increases profitability with greater process uptime and throughput, reduced costs per repair, reduced energy consumption and extended equipment life
- Adjustments to overload configuration can be made at any time

#### Safety

- IP20 rated terminal blocks
- Terminal blocks are set back from the display to reduce operator shock hazard
- Remote display (optional) does not require that the operator open the panel to configure the device

#### Flexibility

- Communications modules
  - Offered in a variety of configurations
  - External snap-on modules provide support for multiple communications protocols
- Advanced power, voltage and current monitoring capabilities
- Communications modules and remote display can be used simultaneously
- Highly configurable fault and reset characteristics for numerous applications
- Fully programmable isolated fault and auxiliary relays

#### Ease of Use

- Bright LED display with easy-to-understand setting and references
- Powered from line voltage or 120 Vac control power
- Remote display powered from base unit
- Full word descriptions and units on user interface

- CSA® certified (Class 3211-02)
- CE
- NEMA®

- IEC EN 60947-4-1
- RoHS



# 5.4

## Motor Protection and Monitoring

### Overload Relays

#### Catalog Number Selection

#### Motor Insight Overload Relays

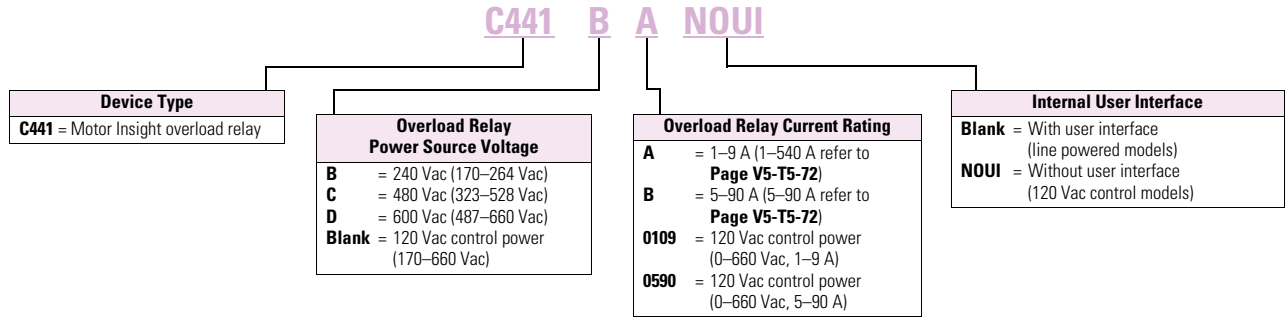

#### Motor Insight High Voltage Overload Relays

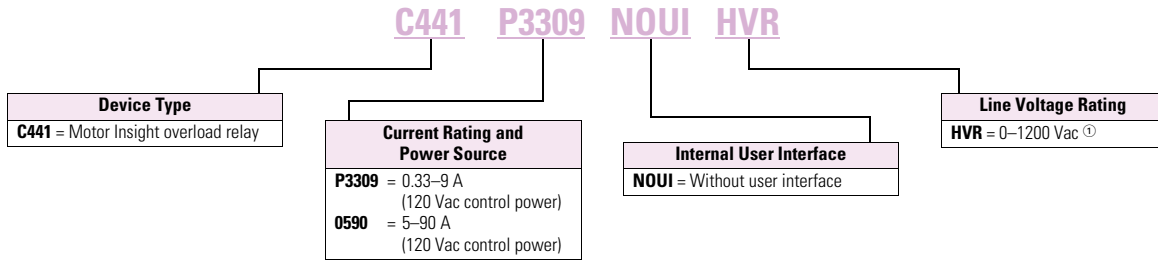

#### Motor Insight Overload Relays—Communications Modules and Accessory Types

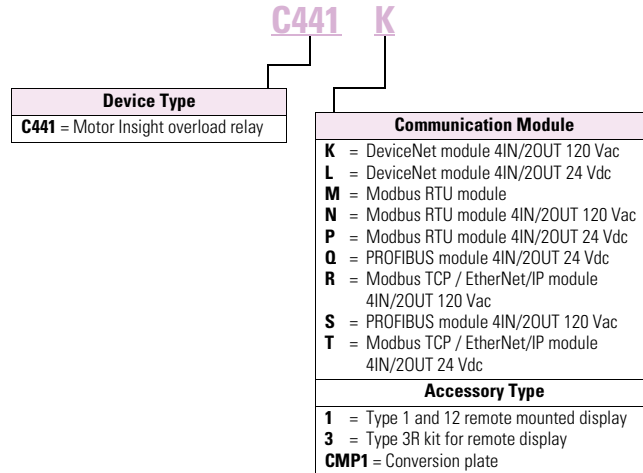

**Note**

① The C441 High Voltage Relay (-HVR models) can be used on systems up to 1200 Vac to provide overload and current based protections. Voltage and power based protections and monitoring listed in this catalog for C441 Motor Insight are not available in -HVR models. Please consult IL04209007E-HVR for technical information on -HVR models.

### Product Selection

#### Motor Insight



#### Motor Insight

Power Source	Monitoring Range	Current Range	Catalog Number
240 Vac (170–264)	170–264 Vac	1–9 A	<b>C441BA</b>
		5–90 A	<b>C441BB</b>
480 Vac (323–528)	323–528 Vac	1–9 A	<b>C441CA</b>
		5–90 A	<b>C441CB</b>
600 Vac (489–660)	489–660 Vac	1–9 A	<b>C441DA</b>
		5–90 A	<b>C441DB</b>
120 Vac (93.5–132)	170–660 Vac	1–9 A	<b>C4410109NOUI</b>
		5–90 A	<b>C4410590NOUI</b>
120 Vac (93.5–132)	0–1200 Vac <sup>①</sup>	0.33–9 A	<b>C441P3309NOUI-HVR</b>
		5–90 A	<b>C4410590NOUI-HVR</b>

**Note**

<sup>①</sup> Rating only—does not provide voltage monitoring/protection.



## Motor Insight CT Multiplier and Wire Wrap Schedule

Catalog Number ①	Motor FLA	Number of Loops	Number of Conductors Through CT Primary	CT Multiplier Setting	External CT Kit Catalog Number ②
<b>Current Range: 5–90 A</b>					
<b>C441_B and C4410590NOUI</b>	5–22.5 A	3	4	4	—
	6.67–30 A	2	3	3	—
	10–45 A	1	2	2	—
	20–90 A	0	1	1	—
<b>Current Range: 1–9 A</b>					
<b>C441_A and C4410109NOUI</b>	1–5 A	1	2	2	—
	2–9 A	0	1	1	—
	60–135 A	0	1	150–(150:5)	<b>C441CTKIT150</b>
	120–270 A	0	1	300–(300:5)	<b>C441CTKIT300</b>
	240–540 A	0	1	600–(600:5)	<b>C441CTKIT600</b>
<b>Current Range: 5–90A</b>					
<b>C4410590NOUI-HVR</b>	5–22.5 A	3	4	4	—
	6.67–30 A	2	3	3	—
	10–45 A	1	2	2	—
	20–90 A	0	1	1	—
<b>Current Range: 0.33–9 A</b>					
<b>C441P3309NOUI-HVR</b>	0.33–1.5 A	5	6	6	—
	0.4–1.8 A	4	5	5	—
	0.5–2.25 A	3	4	4	—
	0.67–3.0 A	2	3	3	—
	1–5 A	1	2	2	—
	2–9 A	0	1	1	—
	60–135 A	0	1	150–(150:5)	<b>C441CTKIT150</b>
	120–270 A	0	1	300–(300:5)	<b>C441CTKIT300</b>
	240–270 A	0	1	600–(600:5)	<b>C441CTKIT600</b>

**Notes**

① Underscore indicates Operating Voltage Code required.  
Operating Voltage Codes:

Code	Voltage
<b>B</b>	240 Vac
<b>C</b>	480 Vac
<b>D</b>	600 Vac
<b>&lt;empty&gt;</b>	120 Vac Control Power

② Any manufacturer's CTs may be used.

### Accessories

#### Communication Modules

Motor Insight Communication Modules mount to the side of the device to provide communication, monitoring and control over a variety of networks.

#### Features and Benefits

##### Ethernet Modules

- Single device supports both EtherNet/IP, Modbus TCP
- Internal switch with two Ethernet ports allows linear or ring network configurations
- Embedded web-services for easy configuration and monitoring with Internet Explorer

##### DeviceNet

- I/O assemblies with the same size and layout as the legacy Advantage (WPONIDNA) and **IT** (DSNAP) Starter platforms for seamless upgrades to C441 technology with no program changes
- Communication uses only one DeviceNet MAC ID

##### PROFIBUS

- Capable of baud rates up to 12 Mb
- Intuitive configuration with common PROFIBUS tools

##### Modbus

- Modbus address and baud rate can be changed easily with C441's user interface (C441M only)

##### Terminals

- Unique locking mechanism provides easy removal of terminal block with field wiring installed
- Marked terminals for ease of wiring and troubleshooting

#### On-board I/O assemblies (all modules)

- Modules offer 4 IN / 2 OUT of network programmable I/O
- 24 Vdc or 120 Vac signal options
- Optical isolation protects the I/O and communication circuits from possible damage due to transients and ground loops
- Inputs feature user-definable debounce, which limits the effects of transients and electrical noise
- Outputs feature a user-definable state for loss of communication: hold last state, ON or OFF

#### Communication Modules



#### Communications Modules

Description	I/O	Catalog Number
<b>Ethernet</b>		
Modbus TCP / EtherNet/IP Communication Module 4IN/2OUT	120 Vac	<b>C441R</b>
Modbus TCP / EtherNet/IP Communication Module 4IN/2OUT	24 Vdc	<b>C441T</b>
<b>DeviceNet</b>		
DeviceNet Communication Module	120 Vac	<b>C441K</b>
DeviceNet Communication Module	24 Vdc	<b>C441L</b>
<b>PROFIBUS</b>		
PROFIBUS Communication Module 4IN/2OUT	120 Vac	<b>C441S</b>
PROFIBUS Communication Module 4IN/2OUT	24 Vdc	<b>C441Q</b>
<b>Modbus</b>		
Modbus Communication Module	None	<b>C441M</b>
Modbus Communication Module 4IN/2OUT	120 Vac	<b>C441N</b>
Modbus Communication Module 4IN/2OUT	24 Vdc	<b>C441P</b>

#### Type 3R Kit with Remote Display Mounted Inside



Motor Insight offers several accessories for the customer's ease of use and safety:

- Types 1 and 12 remote display
- Type 3R remote display kit
- Conversion mounting plate for upgrading from the legacy Eaton 777 model with no new holes required

#### Features and Benefits

- Remote display unit:
  - Same user interface as the overload relay
  - Enhanced operator safety—operator can configure the overload without opening the enclosure door
- Type 3R kit mounts with standard 30 mm holes
- Mounting plate for retrofit in existing installations

#### Type 3R Kit with Remote Display Mounted Inside

Description	Catalog Number
<b>C4411</b> Remote display Types 1 and 12 (UL 508)	<b>C4411</b>
	
<b>C4413</b> Type 3R kit for remote display (UL 508)	<b>C4413</b>
Conversion mounting plate (not shown)	<b>C441CMP1</b>
	

#### Communication Cables

The Remote Display requires a communication cable to connect to the Motor Insight overload relay:

#### Communication Cable Lengths

Length in Inches (meters)	Catalog Number
9.8 (0.25)	<b>D77E-QPIP25</b>
39.4 (1.0)	<b>D77E-QPIP100</b>
78.7 (2.0)	<b>D77E-QPIP200</b>
118.1 (3.0)	<b>D77E-QPIP300</b>

#### Current Transformer Kits

Description	Catalog Number
Three 150:5 CTs to be used with Motor Insight	<b>C441CTKIT150</b>
Three 300:5 CTs to be used with Motor Insight	<b>C441CTKIT300</b>
Three 600:5 CTs to be used with Motor Insight	<b>C441CTKIT600</b>

**Technical Data and Specifications**

**Motor Insight**

Description	Specification C441B_	C441C_	C441D_	C441_ _ _ _ _ NOUI	
<b>Electrical Ratings</b>					
<b>Feature</b>	<b>Range</b>				
Operating voltage (three-phase) and frequency	170–264 Vac 50/60 Hz	323–528 Vac 50/60 Hz	489–660 Vac 50/60 Hz	170–660 Vac 50/60 Hz	
<b>Trip Class</b>					
5–30	Selectable	Selectable	Selectable	Selectable	
<b>FLA Range</b>					
C441_A and C4410109NOUI	1–9 A	Up to 540 A with external CTs Refer to <b>Page V5-T5-72</b> for CT multiplier and wire wrap schedule.	Up to 540 A with external CTs Refer to <b>Page V5-T5-72</b> for CT multiplier and wire wrap schedule.	Up to 540 A with external CTs Refer to <b>Page V5-T5-72</b> for CT multiplier and wire wrap schedule.	
C441_B and C4410590NOUI	5–90 A				
<b>Monitoring Capabilities</b>					
<b>Feature</b>	<b>Value</b>				
Current	Per phase rms (1A, 1B, 1C), 2% accuracy Average rms, 2% accuracy Imbalance percent (0–100%) Ground fault current, 10% accuracy	Per phase rms (1A, 1B, 1C), 2% accuracy Average rms, 2% accuracy Imbalance percent (0–100%) Ground fault current, 10% accuracy	Per phase rms (1A, 1B, 1C), 2% accuracy Average rms, 2% accuracy Imbalance percent (0–100%) Ground fault current, 10% accuracy	Per phase rms (1A, 1B, 1C), 2% accuracy Average rms, 2% accuracy Imbalance percent (0–100%) Ground fault current, 10% accuracy	
Voltage	Per phase rms (1A, 1B, 1C), 2% accuracy Average rms, 2% accuracy Imbalance percent (0–100%)	Per phase rms (1A, 1B, 1C), 2% accuracy Average rms, 2% accuracy Imbalance percent (0–100%)	Per phase rms (1A, 1B, 1C), 2% accuracy Average rms, 2% accuracy Imbalance percent (0–100%)	Per phase rms (1A, 1B, 1C), 2% accuracy Average rms, 2% accuracy Imbalance percent (0–100%)	
Power	Motor kW, 5% accuracy Motor power factor, inductive 0–1.0, 1% accuracy	Motor kW, 5% accuracy Motor power factor, inductive 0–1.0, 1% accuracy	Motor kW, 5% accuracy Motor power factor, inductive 0–1.0, 1% accuracy	Motor kW, 5% accuracy Motor power factor, inductive 0–1.0, 1% accuracy	
Thermal capacity	0% cold, 100% trip	0% cold, 100% trip	0% cold, 100% trip	0% cold, 100% trip	
Motor run hours	0–65,535 hours	0–65,535 hours	0–65,535 hours	0–65,535 hours	
Frequency	47–63 Hz, 1% accuracy	47–63 Hz, 1% accuracy	47–63 Hz, 1% accuracy	47–63 Hz, 1% accuracy	
<b>Motor Protection</b>					
Thermal overload setting	1.05 x FLA: Does not trip 1.15 x FLA: Overload trip	1.05 x FLA: Does not trip 1.15 x FLA: Overload trip	1.05 x FLA: Does not trip 1.15 x FLA: Overload trip	1.05 x FLA: Does not trip 1.15 x FLA: Overload trip	
<b>Feature</b>	<b>Range</b>				<b>Fault Delay Setting</b>
Jam	150–400% of motor FLA, OFF	150–400% of motor FLA, OFF	150–400% of motor FLA, OFF	50–400% of motor FLA, OFF	1–20 seconds
Current imbalance	1–30%, OFF	1–30%, OFF	1–30%, OFF	1–30%, OFF	1–20 seconds
Current phase loss	Fixed threshold 60%	Fixed threshold 60%	Fixed threshold 60%	Fixed threshold 60%	1–20 seconds
Ground fault current					
C441_A and C4410109NOUI 1–9 A	0.3–2.0 A with one pass through the CTs <sup>①</sup>	0.3–2.0 A with one pass through the CTs <sup>①</sup>	0.3–2.0 A with one pass through the CTs <sup>①</sup>	0.3–2.0 A with one pass through the CTs <sup>①</sup>	<150%, 1–60 seconds >150%, 2 seconds >250%, 1 second
C441_B and C4410590NOUI 5–90 A	3.0–20 A with one pass through the CTs <sup>①</sup>	3.0–20 A with one pass through the CTs <sup>①</sup>	3.0–20 A with one pass through the CTs <sup>①</sup>	3.0–20 A with one pass through the CTs <sup>①</sup>	<150%, 1–60 seconds >150%, 2 seconds >250%, 1 second
Phase reversal	OFF = Ignore, 1 = ACB, 2 = ABC	OFF = Ignore, 1 = ACB, 2 = ABC	OFF = Ignore, 1 = ACB, 2 = ABC	OFF = Ignore, 1 = ACB, 2 = ABC	
Fault reset delay	2–500 minutes, auto <sup>②</sup>	2–500 minutes, auto <sup>②</sup>	2–500 minutes, auto <sup>②</sup>	2–500 minutes, auto <sup>②</sup>	
Fault reset attempts	0–4 restarts allowed or automatic reset <sup>②</sup>	0–4 restarts allowed or automatic reset <sup>②</sup>	0–4 restarts allowed or automatic reset <sup>②</sup>	0–4 restarts allowed or automatic reset <sup>②</sup>	

**Notes**

<sup>①</sup> Lower levels are achievable with multiple passes.

<sup>②</sup> Motor fault reset characteristics can be programmed as a group or for motor overloads only. Reference the user manual for more detailed information.

**Motor Insight, continued**

Description	Specification C441B_	C441C_	C441D_	C441_ _ _ _NOUI	
<b>Load Protection</b>					
<b>Feature</b>	<b>Range</b>				<b>Fault Delay Setting</b>
Under current	50–90% of motor FLA	50–90% of motor FLA	50–90% of motor FLA	50–90% of motor FLA	1–60 seconds
Low power (kW)	20–80% of rated kW	20–80% of rated kW	20–80% of rated kW	20–80% of rated kW	1–60 seconds
High power (kW)	50–110% of rated kW	50–110% of rated kW	50–110% of rated kW	50–110% of rated kW	1–60 seconds
Load reset delay	2–500 minutes, auto	2–500 minutes, auto	2–500 minutes, auto	2–500 minutes, auto	
Load reset attempts	0–4, auto	0–4, auto	0–4, auto	0–4, auto	
<b>Supply Protection</b>					
<b>Feature</b>	<b>Range</b>				<b>Fault Delay Setting</b>
Over voltage	170–264 Vac	323–528 Vac	489–660 Vac	0–660 Vac	1–20 seconds
Under voltage	170–264 Vac	323–528 Vac	489–660 Vac	0–660 Vac	1–20 seconds
Voltage imbalance	1–20% imbalance	1–20% imbalance	1–20% imbalance	1–20% imbalance	1–20% imbalance
Restart delay setting	1–500 seconds	1–500 seconds	1–500 seconds	1–500 seconds	1–500 seconds
<b>Electrical/EMC</b>					
Radiated emissions IEC 60947-4-1—Table 15, EN 55011 (CISPR 11) Group 1, Class A	30–1000 MHz	30–1000 MHz	30–1000 MHz	30–1000 MHz	30–1000 MHz
Conducted emissions IEC 60947-4-1—Table 14, EN 55011 (CISPR 11) Group 1, Class A	0.15–30 MHz	0.15–30 MHz	0.15–30 MHz	0.15–30 MHz	0.15–30 MHz
ESD immunity IEC 60947-4-1 (Table 13)	±8 kV air, ±4 kV contact	±8 kV air, ±4 kV contact	±8 kV air, ±4 kV contact	±8 kV air, ±4 kV contact	±8 kV air, ±4 kV contact
Radiated immunity IEC 60947-4-1	10 V/m 80–1000 MHz 80% amplitude modulated 1 kHz sine wave	10 V/m 80–1000 MHz 80% amplitude modulated 1 kHz sine wave	10 V/m 80–1000 MHz 80% amplitude modulated 1 kHz sine wave	10 V/m 80–1000 MHz 80% amplitude modulated 1 kHz sine wave	10 V/m 80–1000 MHz 80% amplitude modulated 1 kHz sine wave
Conducted immunity IEC 60947-4-1	140 dBuV (10 V rms) 150 kHz–80 MHz	140 dBuV (10 V rms) 150 kHz–80 MHz	140 dBuV (10 V rms) 150 kHz–80 MHz	140 dBuV (10 V rms) 150 kHz–80 MHz	140 dBuV (10 V rms) 150 kHz–80 MHz
Fast transient immunity IEC 60947-4-1 (Table 13) IEC 61000-4-4	±2 kV using direct method	±2 kV using direct method	±2 kV using direct method	±2 kV using direct method	±2 kV using direct method
Surge immunity IEC 60947-4-1 (Table 13) IEC 61000-4-4	Three-phase power inputs: ±2 kV line-to-line (DM) ±4 kV line-to-ground (CM)  IEC 61000-4-5 Class 3 User IO and communication lines: ±1 kV line-to-line (DM) ±2 kV line-to-ground (CM)	Three-phase power inputs: ±2 kV line-to-line (DM) ±4 kV line-to-ground (CM)  IEC 61000-4-5 Class 3 User IO and communication lines: ±1 kV line-to-line (DM) ±2 kV line-to-ground (CM)	Three-phase power inputs: ±2 kV line-to-line (DM) ±4 kV line-to-ground (CM)  IEC 61000-4-5 Class 3 User IO and communication lines: ±1 kV line-to-line (DM) ±2 kV line-to-ground (CM)	Three-phase power inputs: ±2 kV line-to-line (DM) ±4 kV line-to-ground (CM)  IEC 61000-4-5 Class 3 User IO and communication lines: ±1 kV line-to-line (DM) ±2 kV line-to-ground (CM)	Three-phase power inputs: ±2 kV line-to-line (DM) ±4 kV line-to-ground (CM)  IEC 61000-4-5 Class 3 User IO and communication lines: ±1 kV line-to-line (DM) ±2 kV line-to-ground (CM)
Voltage variations immunity IEC 60947-4-1	30% dip, at 100 ms 60% dip at 10 ms >95% interrupt at 5 ms	30% dip, at 100 ms 60% dip at 10 ms >95% interrupt at 5 ms	30% dip, at 100 ms 60% dip at 10 ms >95% interrupt at 5 ms	30% dip, at 100 ms 60% dip at 10 ms >95% interrupt at 5 ms	30% dip, at 100 ms 60% dip at 10 ms >95% interrupt at 5 ms
Electromagnetic field IEC 60947-4-1 (Table 13) IEC 61000-4-3	10 V/m	10 V/m	10 V/m	10 V/m	10 V/m
Ground fault	UL 508, UL 1053 Sections 21 and 27	UL 508, UL 1053 Sections 21 and 27	UL 508, UL 1053 Sections 21 and 27	UL 508, UL 1053 Sections 21 and 27	UL 508, UL 1053 Sections 21 and 27

### Motor Insight, continued

Description	Specification C441B_	C441C_	C441D_	C441_ __ _NOUI
<b>Environmental Ratings</b>				
<b>Feature</b>	<b>Range</b>			
Ambient temperature (operating)	-4 to 122 °F (-20 to 50 °C)	-4 to 122 °F (-20 to 50 °C)	-4 to 122 °F (-20 to 50 °C)	-4 to 122 °F (-20 to 50 °C)
Ambient temperature (storage)	-40 to 85 °C	-40 to 85 °C	-40 to 85 °C	-40 to 85 °C
Operating humidity	5% to 95% noncondensing	5% to 95% noncondensing	5% to 95% noncondensing	5% to 95% noncondensing
Altitude (no derating)	2000 m	2000 m	2000 m	2000 m
Shock (IEC 60068-2-27)	15 G any direction	15 G any direction	15 G any direction	15 G any direction
Vibration (IEC 60068-2-6)	3 G any direction	3 G any direction	3 G any direction	3 G any direction
Pollution degree per IEC 60947-1	3	3	3	3
Ingress protection	IP20	IP20	IP20	IP20
<b>Capacity</b>				
Input, auxiliary contact and external reset terminals				
Terminal capacity	18–12 AWG	18–12 AWG	18–12 AWG	18–12 AWG
Tightening torque	5.3 lb-in (0.6 Nm)	5.3 lb-in (0.6 Nm)	5.3 lb-in (0.6 Nm)	5.3 lb-in (0.6 Nm)
<b>Voltages</b>				
Monitoring voltage	170–264 Vac 50/60Hz	323–528 Vac 50/60Hz	489–660 Vac 60Hz	0–660 Vac 50/60Hz
Insulation voltage $U_i$ (three-phase voltage)	600 Vac	600 Vac	600 Vac	600 Vac
Insulation voltage $U_i$ (control)	240 Vac	240 Vac	240 Vac	240 Vac
Impulse withstand $U_{imp}$ (main/control)	6 kV	6 kV	6 kV	6 kV
<b>Expected Life</b>				
Mechanical/electrical	10 years	10 years	10 years	10 years
<b>Output Contact Ratings</b>				
Two output relays One Form C SPDT (fault relay) One Form A SPST (ground fault relay)	B300 pilot duty 5 A thermal continuous current 30 A make 3.00 A break at 120 Vac and 15 A make 1.50 A break at 240 Vac	B300 pilot duty 5 A thermal continuous current 30 A make 3.00 A break at 120 Vac and 15 A make 1.50 A break at 240 Vac	B300 pilot duty 5 A thermal continuous current 30 A make 3.00 A break at 120 Vac and 15 A make 1.50 A break at 240 Vac	B300 pilot duty 5 A thermal continuous current 30 A make 3.00 A break at 120 Vac and 30 A make 1.50 A break at 240 Vac <sup>①</sup>
C441_ __ _NOUI models: One Form A SPST One Form B SPST				
External remote reset terminal	Isolated 120 Vac digital input IEC 61131-2 Section 5 Type 1	Isolated 120 Vac digital input IEC 61131-2 Section 5 Type 1	Isolated 120 Vac digital input IEC 61131-2 Section 5 Type 1	Isolated 120 Vac digital input IEC 61131-2 Section 5 Type 1
<b>Indications</b>				
Trip	Fault	Fault	Fault	Fault
Reset	Ready	Ready	Ready	Ready
Autoreset	Trip faulted/Ready flashing	Trip faulted/Ready flashing	Trip faulted/Ready flashing	Trip faulted/Ready flashing
<b>Power Consumption</b>				
Maximum	5W	5W	5W	5W
<b>Options</b>				
Remote display	Type 1, 12 and Type 3R kit	Type 1, 12 and Type 3R kit	Type 1, 12 and Type 3R kit	Type 1, 12 and Type 3R kit
Communications modules	Modbus, DeviceNet and PROFIBUS with I/O	Modbus, DeviceNet and PROFIBUS with I/O	Modbus, DeviceNet and PROFIBUS with I/O	Modbus, DeviceNet and PROFIBUS with I/O

**Note**

① In this model, there are two isolated relays: one Form A and one Form B SPST. One is the fault relay, and one is a programmable auxiliary relay.

# 5.4

## Motor Protection and Monitoring

### Overload Relays

5

#### Motor Insight Short Circuit Ratings (North America CSA and UL)

Overload FLA Range	Maximum Operating Voltage	Standard-Fault Short Circuit Data			Maximum Withstand Rating	Maximum Fuse (RK5)	Eaton Thermal-Magnetic Circuit Breaker	Catalog Number
		Withstand Rating	Maximum Fuse (RK5)	Maximum Thermal-Magnetic Circuit Breaker				
1–9 A	264 Vac	5000 A at 240 Vac	35 A	35 A	100 kA at 240 Vac	35 A	—	<b>C441BA</b>
					100 kA at 240 Vac	—	FDC3035L	
1–9 A	528 Vac	5000 A at 480 Vac	35 A	35 A	100 kA at 480 Vac	35 A	—	<b>C441CA</b>
					100 kA at 480 Vac	—	FDC3035L	
1–9 A	660 Vac	5000 A at 600 Vac	35 A	35 A	100 kA at 600 Vac	35 A	—	<b>C441DA</b>
					35 kA at 600 Vac	—	FDC3035L	
1–9 A	660 Vac	5000 A at 600 Vac	35 A	35 A	100 kA at 240 Vac	35 A	—	<b>C4410109NOUI</b>
					100 kA at 240 Vac	—	FDC3035L	
					100 kA at 480 Vac	35 A	—	
					100 kA at 480 Vac	—	FDC3035L	
					100 kA at 600 Vac	35 A	—	
5–90 A	264 Vac	10,000 A at 240 Vac	350 A	350 A	100 kA at 240 Vac	350 A	—	<b>C441BB</b>
					100 kA at 240 Vac	—	KDC3350	
5–90 A	528 Vac	10,000 A at 480 Vac	350 A	350 A	100 kA at 480 Vac	350 A	—	<b>C441CB</b>
					100 kA at 480 Vac	—	KDC3350	
5–90 A	660 Vac	10,000 A at 600 Vac	350 A	350 A	100 kA at 600 Vac	350 A	—	<b>C441DB</b>
					65 kA at 600 Vac	—	KDC3350	
5–90 A	660 Vac	10,000 A at 600 Vac	350 A	350 A	100 kA at 240 Vac	350 A	—	<b>C4410590NOUI</b>
					100 kA at 240 Vac	—	KDC3350	
					100 kA at 480 Vac	350 A	—	
					100 kA at 480 Vac	—	KDC3350	
					100 kA at 600 Vac	350 A	—	
35 kA at 600 Vac	—	KDC3350						

### Line Powered Models

#### Terminal Connection Diagram

Use 75C CU wire only

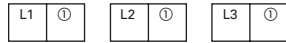

18–12 AWG; Torque 5.3 lb-in/0.6 Nm  
B300 Pilot Duty Only

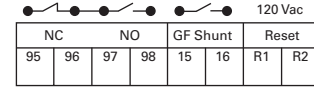

For C441BA, BB, CA, CB, DA and DB



#### Terminal Connection Specifications

Name	Designation	Input	Description
Line voltage	L1, L2, L3	Line voltage	Three-phase line voltage input L1, L2, L3 connections must correspond to the respective CT1, CT2, CT3 current leads
Fault relay	95/96 96/97 (common) 97/98	B300 UL 508	Form C contact: 95/96 Contact opens when the unit is faulted or unpowered 97/98 Contact closes when the unit is faulted or unpowered
GF shunt	15 16	B300 UL 508	Form A contact: Contact closes when a ground fault is active
Reset input	R1, R2	120 Vac	Fault reset input IEC 61131-2 Type 1

### Control Powered Models

#### Terminal Connection Diagram

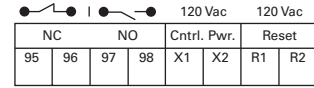
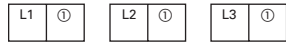

For C4410109NOUI and C441059NOUI



#### Terminal Connection Specifications

Name	Designation	Input	Description
Line voltage	L1, L2, L3	Line voltage	Three-phase line voltage input L1, L2, L3 connections must correspond to the respective CT1, CT2, CT3 current leads Terminal provided for wiring control power transformer (9A maximum capacity)
Control power	X1, X2	110–120 Vac 50–60Hz (+10/–15%)	Control power option for C441___NOUI
Fault relay For C441___NOUI, the fault relay and auxiliary relay are isolated and do not share a common. By default they will behave like a Form C, but they can be programmed to act independently from one another.	95/96 96/97 (isolated) 97/98	B300 UL 508	Form C contact: 95/96 Contact opens when the unit is faulted or unpowered 97/98 Contact closes when the unit is faulted or unpowered Can be programmed to act independently of the 95/96 only in the C441___NOUI models
GF shunt This relay does not exist on the C441___NOUI models. Instead, this functionality is available in the fully programmable 97/98 auxiliary relay.	97/98	B300 UL 508	Form A contact: Contact closes when a ground fault is active Separate GF control can still be achieved by programming auxiliary relay 97/98 to act independently of the 95/96 relay
Reset input	R1, R2	120 Vac	Fault reset input IEC 61131-2 Type 1

#### Note

① No motor loads, 9 A maximum.



### Modbus Communication Modules

Description	Specification	
<b>Electrical/EMC</b>		
Radiated emissions IEC 60947-4-1—Table 15, EN 55011 (CISPIR 11) Group 1, Class A	30–1000 MHz	
Conducted emissions IEC 60947-4-1—Table 14, EN 55011 (CISPIR 11) Group 1, Class A	0.15–30 MHz	
ESD immunity IEC 60947-4-1 (Table 13) IEC 61000-4-2	±8 kV air, ±4 kV contact	
Radiated immunity IEC 60947-4-1	10 V/m 80–1000 MHz 80% amplitude modulated 1 kHz sine wave	
Conducted immunity IEC 60947-4-1	140 dBuV (10 V rms) 150 kHz–80 MHz	
Fast transient immunity IEC 60947-4-1 (Table 13) IEC 61000-4-4	±2 kV using direct method	
Surge immunity IEC 60947-4-1 (Table 13) IEC 61000-4-5 Class 3	User IO and communication lines <sup>①</sup> : ±1 kV line-to-line (DM) ±2 kV line-to-ground (CM)	
Electromagnetic field <sup>①</sup> IEC 60947-4-1 (Table 13) IEC 61000-4-3	10 V/m	
<b>Environmental Ratings</b>		
Ambient temperature (operating)	–20 to 50 °C	
Ambient temperature (storage)	–40 to 85 °C	
Operating humidity	5 to 95% noncondensing	
Altitude (no derating)	2000 m	
Shock (IEC 60068-2-27)	15 G any direction	
Vibration (IEC 60068-2-6)	3 G any direction	
Pollution degree per IEC 60947-1	3	
Degree of protection	IP20	
Over voltage category per UL 508	III	
<b>C441P 24 Vdc Input</b>		
Nominal input voltage	24 Vdc	
Operating voltage	18–30 Vdc	
Number of inputs	4	
Signal delay	5 ms (programmable to 65 sec)	
OFF-state voltage	<6 Vdc	
ON-state voltage	>18 Vdc	
Nominal input current	5 mA	
Isolation	1500 V	
Terminal screw torque	7–9 in-lb	
24 Vdc source current	50 mA	
<b>Operating Voltage Range—DC Input Modules</b>		
<b>OFF State</b>	<b>Transition Region</b>	<b>ON State</b>
0–6 Vdc	6–18 Vdc	18–30 Vdc
<b>C441N 120 Vac Input</b>		
Nominal input voltage	120 Vac	
Operating voltage	80–140 Vac	
Number of inputs	4	
OFF-state voltage	<30 Vac	
ON-state voltage	>80 Vac	
Nominal input current	15 mA	
Signal delay	1/2 cycle	
Isolation	1500 V	
Terminal screw torque	7–9 in-lb	

**Note**

<sup>①</sup> Relates to C441M only.

**Modbus Communication Modules, continued**

Description	Specification	
<b>Operating Voltage Range—AC Input Modules</b>		
<b>OFF State</b>	<b>Transition Region</b>	<b>ON State</b>
0–30 Vac	30–80 Vac	80–140 Vac
<b>Output Modules</b>		
Nominal voltage	120 Vac 24 Vdc	
Number of outputs	(2) 1NO Form A 1NO/NC Form C	
Relay OFF time	3 ms	
Relay ON time	7 ms	
Max. current per point <sup>①</sup>	5 A (B300 rated)	
Electrical life	100,000 cycles	
Mechanical life	1,000,000 cycles	

**DeviceNet Communication Modules**

Description	Specification
<b>Electrical/EMC</b>	
Radiated emissions IEC 60947-4-1—Table 15, EN 55011 (CISPR 11) Group 1, Class A	30–1000 MHz
Conducted emissions IEC 60947-4-1—Table 14, EN 55011 (CISPR 11) Group 1, Class A	0.15–30 MHz
ESD immunity IEC 60947-4-1 (Table 13) IEC 61000-4-2	±8 kV air, ±4 kV contact
Radiated immunity IEC 60947-4-1	10 V/m 80–1000 MHz 80% amplitude modulated 1 kHz sine wave
Conducted immunity IEC 60947-4-1	140 dBuV (10 V rms) 150 kHz–80 MHz
Fast transient immunity IEC 60947-4-1 (Table 13) IEC 61000-4-4	±2 kV using direct method
Surge immunity IEC 60947-4-1 (Table 13) IEC 61000-4-5 Class 2	User IO and communication lines: ±1 kV line-to-line (DM) ±2 kV line-to-ground (CM)
Electromagnetic field IEC 60947-4-1 Table 13, IEC 61000-4-3	10 V/m
<b>Environmental Ratings</b>	
Ambient temperature (operating)	–20 to 50 °C
Ambient temperature (storage)	–40 to 85 °C
Operating humidity	5–95% noncondensing
Altitude (no derating)	2000 m
Shock (IEC 60068-2-27)	15 G any direction
Vibration (IEC 60068-2-6)	3 G any direction
Pollution degree per IEC 60947-1	3
Degree of protection	IP20
<b>DeviceNet</b>	
DeviceNet connections	Group 2, polling, bit strobe, explicit, no UCMM
DeviceNet baud rate	125 K, 250 K, 500 K

**Note**

<sup>①</sup> Resistive current at 55 °C ambient.

**DeviceNet Communication Modules, continued**

<b>Description</b>	<b>Specification</b>	
<b>C441L 24 Vdc Input</b>		
Nominal input voltage	24 Vdc	
Operating voltage	18–30 Vdc	
Number of inputs	4	
Signal delay	5 ms (programmable to 65 sec)	
OFF-state voltage	<6 Vdc	
ON-state voltage	>18 Vdc	
Nominal input current	5 mA	
Isolation	250 V	
Terminal screw torque	7–9 in-lb	
24 V source current	50 mA	
<b>Operating Voltage Range—DC Input Modules</b>		
<b>OFF State</b>	<b>Transition Region</b>	<b>ON State</b>
0–6 Vdc	6–18 Vdc	18–30 Vdc
<b>C441K 120 Vac Input</b>		
Nominal input voltage	120 Vac	
Operating voltage	80–140 Vac	
Number of inputs	4	
OFF-state voltage	<30 Vac	
ON-state voltage	>80 Vac	
Nominal input current	15 mA	
Signal delay	1/2 cycle	
Isolation	250 V	
Terminal screw torque	7–9 in-lb	
<b>Operating Voltage Range—AC Input Modules</b>		
<b>OFF State</b>	<b>Transition Region</b>	<b>ON State</b>
0–30 Vac	30–80 Vac	80–140 Vac
<b>Output Modules</b>		
Nominal voltage	120 Vac 24 Vdc	
Number of outputs	(2) 1NO Form A 1NO/NC Form C	
Relay OFF time	3 ms	
Relay ON time	7 ms	
Max. current per point <sup>①</sup>	5 A (B300 rated)	
Electrical life	100,000 cycles	
Mechanical life	1,000,000 cycles	

**Note**

<sup>①</sup> Resistive current at 55 °C ambient.

**PROFIBUS Communication Modules**

Description	Specification
<b>Electrical/EMC</b>	
Radiated emissions IEC 60947-4-1—Table 15, EN 55011 (CISPR 11) Group 1, Class A	30–1000 MHz
Conducted emissions IEC 60947-4-1—Table 14, EN 55011 (CISPR 11) Group 1, Class A	0.15–30 MHz
ESD immunity IEC 60947-4-1 (Table 13) IEC 61000-4-2	±8 kV air, ±4 kV contact
Radiated immunity IEC 60947-4-1 Table 13, IEC 61000-4-3	10 V/m 80–1000 MHz 80% amplitude modulated 1 kHz sine wave
Conducted immunity IEC 60947-4-1	140 dBuV (10 V rms) 150 kHz–80 MHz
Fast transient immunity IEC 60947-4-1 (Table 13) IEC 61000-4-4	±2 kV using direct method
Surge immunity IEC 60947-4-1 (Table 13) IEC 61000-4-5 Class 2	User IO and communication lines: ±1 kV line-to-line (DM) ±2 kV line-to-ground (CM)
<b>Environmental Ratings</b>	
Ambient temperature (operating)	–20 to 50 °C
Ambient temperature (storage)	–40 to 85 °C
Operating humidity	5–95% noncondensing
Altitude (no derating)	2000 m
Shock (IEC 60068-2-27)	15 G any direction
Vibration (IEC 60068-2-6)	3 G any direction
Pollution degree per IEC 60947-1	3
Degree of protection	IP20
<b>PROFIBUS</b>	
PROFIBUS connections	Group 2, polling, bit strobe, explicit, no UCMM
PROFIBUS baud rate	9.6 K, 19.2 K, 45.45 K, 93.75 K, 187.5 K, 500 K, 1.5 M, 3 M, 6 M, 12 M
<b>C441Q 24 Vdc Input</b>	
Nominal input voltage	24 Vdc
Operating voltage	18–30 Vdc
Number of inputs	4
Signal delay	5 ms (programmable to 65 sec)
OFF-state voltage	<6 Vdc
ON-state voltage	>10 Vdc
Nominal input current	5 mA
Isolation	1500 V
Terminal screw torque	7–9 in-lb
24 V source current	50 mA

**PROFIBUS Communication Modules, continued**

Description	Specification	
<b>Operating Voltage Range—DC Input Modules</b>		
<b>OFF State</b>	<b>Transition Region</b>	<b>ON State</b>
0–6 Vdc	6–18 Vdc	18–30 Vdc
<b>C441S 120 Vac Input</b>		
Nominal input voltage	120 Vac	
Operating voltage	80–140 Vac	
Number of inputs	4	
OFF-state voltage	<20 Vac	
ON-state voltage	>70 Vac	
Nominal input current	15 mA	
Signal delay	1/2 cycle	
Isolation	1500 V	
Terminal screw torque	7–9 in-lb	
<b>Operating Voltage Range—AC Input Modules</b>		
<b>OFF State</b>	<b>Transition Region</b>	<b>ON State</b>
0–30 Vac	30–80 Vac	80–140 Vac
<b>Output Modules</b>		
Nominal voltage	120 Vac 24 Vdc	
Number of outputs	(2) 1NO Form A 1NO/NC Form C	
Relay OFF time	3 ms	
Relay ON time	7 ms	
Max. current per point <sup>①</sup>	5 A (B300 rated)	
Electrical life	100,000 cycles	
Mechanical life	1,000,000 cycles	

**Note**

<sup>①</sup> Resistive current at 55 °C ambient.

**Ethernet (Modbus TCP / EtherNet/IP) Communication Modules**

Description	Specification
<b>Electrical/EMC</b>	
Radiated emissions IEC 60947-4-1, Table 15, EN 55011 (CISPR 11) Group 1, Class A	30–1000 MHz
Conducted emissions IEC 60947-4-1, Table 15, EN 55011 (CISPR 11) Group 1, Class A	0.15–30 MHz
ESD immunity IEC 60947-4-1 (Table 13) IEC 61000-4-2	±8 kV air, ±4 kV contact
Radiated immunity IEC 60947-4-1 (Table 13) IEC 61000-4-3	10 V/m 80–1000 MHz 80% amplitude modulated 1 kHz sine wave
Conducted immunity IEC 60947-4-1	140 dBuV (10 V rms) 150 kHz to 80 MHz
Fast transient immunity IEC 60947-4-1 (Table 13) IEC 61000-4-4	±2 kV using direct method
Surge immunity IEC 60947-4-1 (Table 13) IEC 61000-4-5 Class 2	User IO and communication lines: ±1 kV line-to-line (DM) ±2 kV line-to-ground (CM)
<b>Environmental Ratings</b>	
Ambient temperature (operating)	–20 to 50 °C
Ambient temperature (storage)	–40 to 85 °C
Operating humidity	5–95% noncondensing
Altitude (no derating)	2000 m
Shock (IEC 60068-2-27)	15 G any direction
Vibration (IEC 60068-2-6)	3 G any direction
Pollution degree per IEC 60947-1	3
Degree of protection	IP20
<b>Ethernet</b>	
Ethernet connections	Integrated two-port switch with dual RJ45 Ethernet connections
Ethernet type	Ethernet 10/100 Mbs, AutoMDX, Auto Negotiation
<b>C441T 24 Vdc Input</b>	
Nominal input voltage	24 Vdc
Operating voltage	18–30 Vdc
Number of inputs	4
Signal delay	5 ms (programmable to 65 sec)
OFF-state voltage	<6 Vdc
ON-state voltage	>18 Vdc
Nominal input current	5 mA
Isolation	1500 V
Terminal screw torque	7–9 in-lb
24 V source current	50 mA

## Ethernet (Modbus TCP / EtherNet/IP) Communication Modules, continued

Description	Specification	
<b>Operating Voltage Range—DC Input Modules</b>		
<b>OFF State</b>	<b>Transition Region</b>	<b>ON State</b>
0–6 Vdc	6–18 Vdc	18–30 Vdc
<b>C441R 120 Vac Input</b>		
Nominal input voltage	120 Vac	
Operating voltage	80–140 Vac	
Number of inputs	4	
OFF-state voltage	<30 Vac	
ON-state voltage	>80 Vac	
Nominal input current	15 mA	
Signal delay	1/2 cycle	
Isolation	1500 V	
Terminal screw torque	7–9 in-lb	
<b>Operating Voltage Range—AC Input Modules</b>		
<b>OFF State</b>	<b>Transition Region</b>	<b>ON State</b>
0–30 Vac	30–80 Vac	80–140 Vac
Nominal voltage	120 Vac 24 Vdc	
Number of outputs	(2) 1NO Form A 1NO/NC Form C	
Relay OFF time	3 ms	
Relay ON time	7 ms	
Maximum current per point <sup>①</sup>	5 A (B300 rated)	
Electrical life	100,000 cycles	
Mechanical life	1,000,000 cycles	

**Note**

<sup>①</sup> Resistive current at 55 °C ambient.

### Dimensions

Approximate Dimensions in Inches (mm)

#### Motor Insight Overload Relay

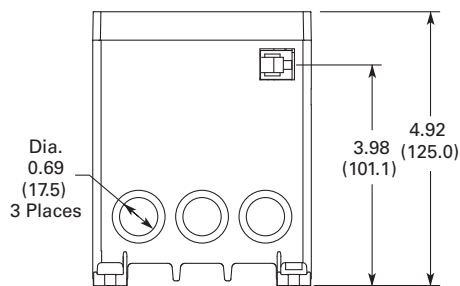
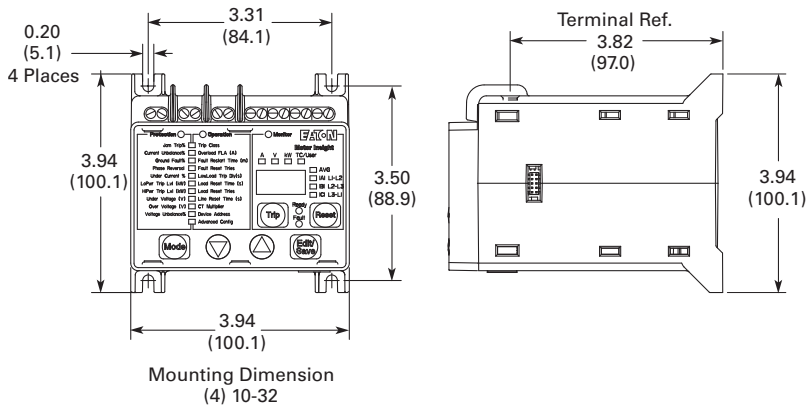

#### Motor Insight with Mounted DeviceNet, PROFIBUS or Modbus with I/O Communication Module

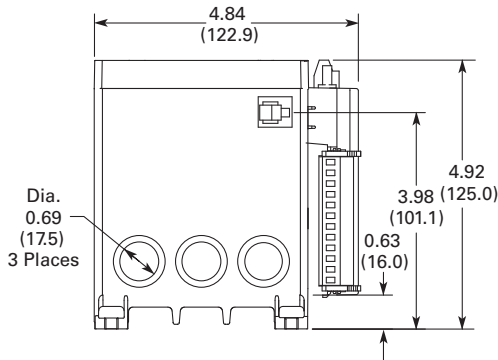
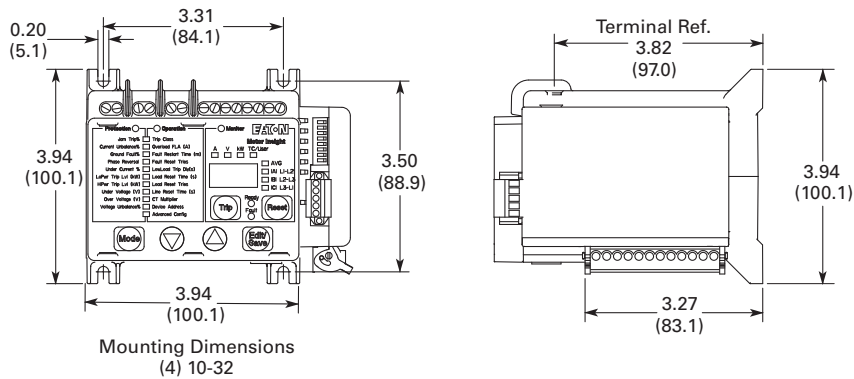



# 5.4 Motor Protection and Monitoring

## Overload Relays

Approximate Dimensions in Inches (mm)

### Motor Insight with Mounted Modbus Communication Module

5

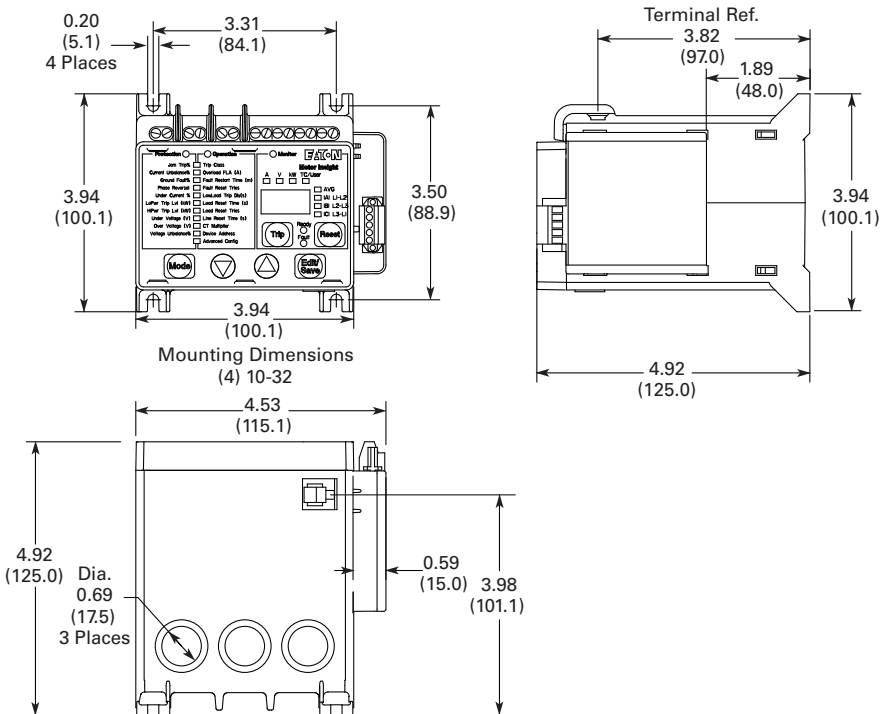

### Motor Insight Remote Display

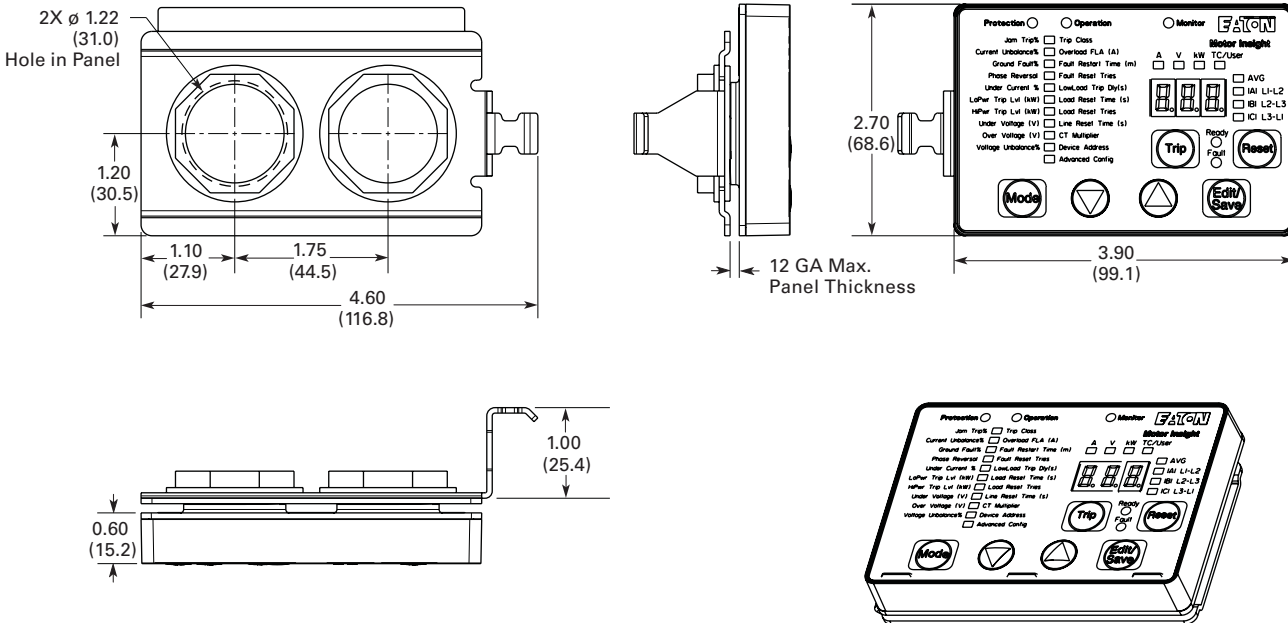

Approximate Dimensions in Inches (mm)

**Motor Insight Cover Assembly**

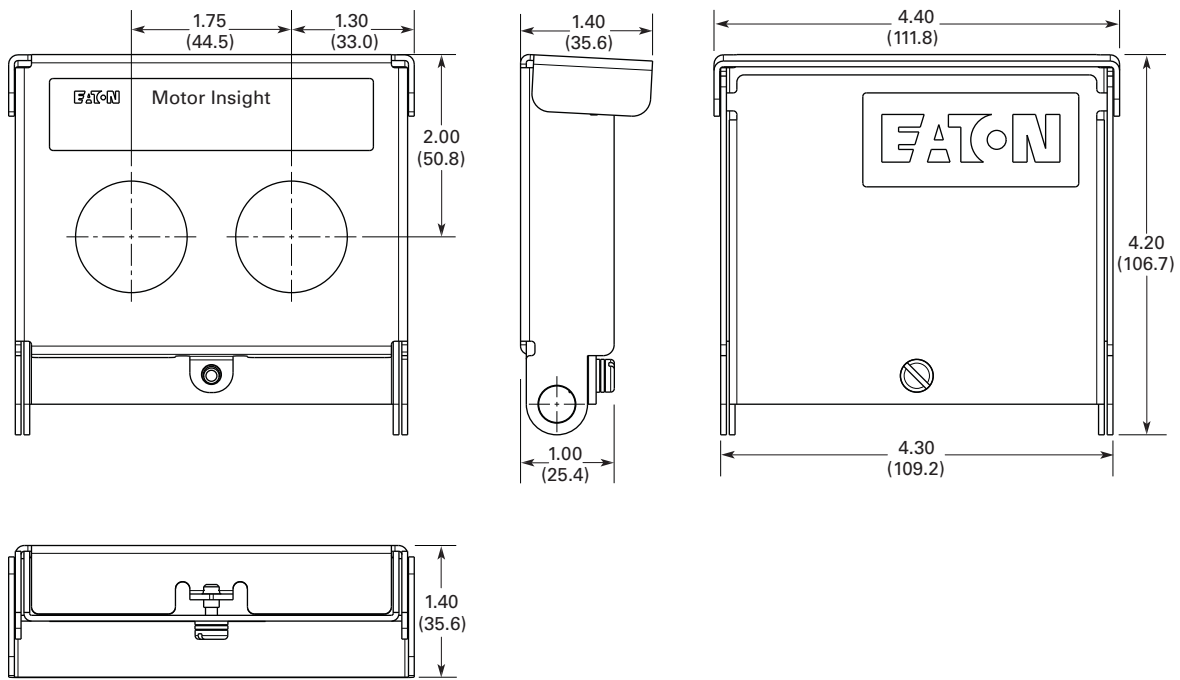

**Conversion Mounting Plate**

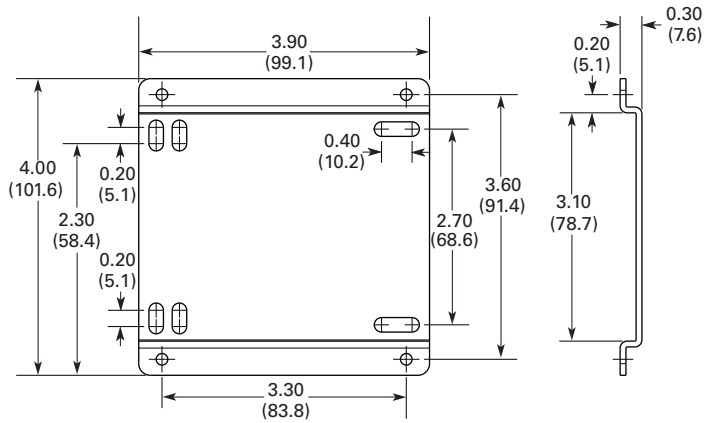

#### Power Xpert C445 Motor Management Relay



#### Contents

##### Description

	<i>Page</i>
<b>XT</b> IEC Overload Relays . . . . .	<b>V5-T5-42</b>
C306 Bimetallic Overload Relays . . . . .	<b>V5-T5-46</b>
C440/ <b>XT</b> Electronic Overload Relay . . . . .	<b>V5-T5-47</b>
C441 Overload Relays . . . . .	<b>V5-T5-68</b>
C445 Motor Management Relay	
Features and Benefits . . . . .	<b>V5-T5-91</b>
Standards and Certifications . . . . .	<b>V5-T5-91</b>
Catalog Number Selection . . . . .	<b>V5-T5-97</b>
Product Selection . . . . .	<b>V5-T5-99</b>
Accessories . . . . .	<b>V5-T5-102</b>
Technical Data and Specifications . . . . .	<b>V5-T5-105</b>
Dimensions . . . . .	<b>V5-T5-108</b>

#### Power Xpert C445 Motor Management Relay

##### Product Description

The Power Xpert C445 global motor management relay is Eaton’s most advanced offering in the C400 series. Customizable control functionality, extensive on-board communications and superior diagnostics and protection make C445 ideal for critical applications where uptime is key. An intuitive interface allows users to safely access all that C445 has to offer—including fault diagnostics, motor system monitoring, ground fault monitoring, on-board function block programming logic, expansion I/O and parameter viewing or setting.

C445 is fully configurable, providing the highest level of monitoring accuracy and protection for the entire power system—from the incoming power source feeding the motor all the way to the individual pump or load. By utilizing integrated energy and power usage analytics, users can save energy costs through increased awareness of energy use at the individual load level.

Due to its unrivaled compact size and modular format, the C445 allows for easy integration into NEMA and IEC motor control centers as well as OEM control panels. By separating the monitoring and control functionality into separate modules, users can customize mounting to their individual application. The combined mounting option provides a complete system just 45 mm wide and 80 mm high for applications up to 45 amps.

Unlike a traditional overload relay, a motor management relay can both control and protect the motor. This eliminates the need to wire dedicated circuits to achieve desired control functionality. Based on this smaller size and flexible control capability, users can reduce costs and improve system flexibility through simplified wiring, smaller enclosure footprint and seamless field modifications as systems evolve over time.

C445 was designed with ease of use and user safety in mind. Users can monitor and configure data parameters without opening the door by using a variety of communication network options, web pages, a free software tool or the easy user interface.

C445 can be integrated into almost any PLC and DCS system through integrated EtherNet/IP, ModbusTCP, PROFIBUS and Modbus Serial. Free tools like Add On Instructions and EIP-Assist make adding C445 to EtherNet/IP networks fast and error free. For non-fieldbus users, C445’s intelligence is still easy to leverage with the user interface or free Power Xpert *inControl* software.

## Features and Benefits

### Features

#### Product Range

- 0.3–800 A
- Up to 690 Vac
- 4160 Vac with PT ratios
- 20–80 Hz operation
- Selectable trip class (5–40)

#### Product Hardware

- Modular design with multiple options:
  - Base control module: protections, monitoring, communications, I/O
  - Measurement module: sensing capability to 136 A
  - Optional combined mounting for systems up to 45 A for a compact offering just 45 mm wide by 80 mm high
  - Easy user interface provides monitoring and programming LCD display with optional control
- AC (120/240) or DC (24) control-power options
- Function block programming and expansion I/O
- Pulsing ground fault detection
- High resistance ground—zero sequence detection
- 2% monitoring accuracy on current and voltage values
- On-board I/O available for control, protection and general purpose use
  - (4) DI (AC or DC options)
  - (3) Relay out
    - 2 Form A (NO)
    - 1 Form C (NO/NC) latching or non-latching
- Optional expansion I/O
  - 16 total I/O cards, 8 of which can be analog or temperature
- Superior motor protection solutions, including:
  - Motor (current)
  - Line (voltage)
  - Load (power)
- Ground fault detection:
  - Residual ground fault detection
  - Pulse detection
  - Zero sequence
- Advanced monitoring algorithms
- Pre-configured operation modes
  - Overload only
  - Direct (FVNR)
  - Reverser (FVR)
  - Star/delta
  - Two speed pole changing
  - Two speed Dahlander
  - Auto transformer
  - Solenoid valve
  - HMCP/MCCB actuation
  - Contactor feeder
  - General purpose input/output
- Flexible on-board communication options
  - Modbus Serial
  - Modbus TCP
  - EtherNet/IP
  - PROFIBUS
  - Web pages
- Real-time clock and memory backup module
- Integrated USB communication port
- Power Xpert *inControl* software tool
  - Configuration
  - Monitoring
  - Diagnostics

### Benefits

#### Intelligence Made Easy

- Advanced fault diagnostics give users complete fault descriptions, a fault snap-shot and queue immediately on the user interface or over the network
- Motor management capabilities save space, time and wiring by eliminating the need for dedicated hardwired control circuits
- Greater system coverage through line-, load- and motor-based protections
- User interface provides easy motor monitoring and immediate delivery of fault diagnostics
- Voltage loss restart functionality allows for automatic revival after outages from voltage loss without the need for user intervention
- On-board I/O meets needs of most communication requirements without the need for additional modules
- Seamless integration into EtherNet/IP networks via EIP-Assist tool
- Pre-programmed operation modes support fast, easy installation for most applications

#### Flexibility

- Modular format with scalable options allows for customization to exact needs of application
- Widest range of communications for easy integration into majority of PLC/DCS systems
- Fully programmable output relays
- Fully programmable trip and alarm thresholds and time delays

## Standards and Certifications

- CE, cULus
- IEC EN 60947-4-1



### System Overview

The Power Xpert C445 Motor Management Relay is a solid-state motor management relay designed to protect single- or three-phase AC electric induction motors from 0.3 to 800 A. C445 provides intelligent monitoring, protection and efficiency calculations for motor, load and line conditions. It's ideal for oil and gas, water treatment, mining, utility and industrial motor control applications. C445 offers a modular pass-through design, breaking the sensing, protection, and control into separate modules. This allows the user to select the appropriate options for each module and combine them to meet the exact needs of their application. Together, these modules provide a fully configurable and industry-leading intelligent motor protection solution for the entire system.

#### Base Control Module

The base control module is the core of the C445 system, providing the various monitoring, protection and control algorithms. Equipped with native I/O connections, communication card options and USB connectivity, the base control module provides users with real-time data on the health and status of their application. Various pre-configured operation modes are available that simplify the wiring and logic requirements for the user.



#### Measurement Module

The measurement module is a pass-through device that samples the system current and voltage. Optionally the residual ground current and pulse detection can be sampled. This data is continuously transmitted back to the base control module for analysis. Various frame sizes are available for applications up to 800 A, with voltage measurement and positive temperature coefficient (PTC) protection options.



#### User Interface

The C445 user interface unlocks advanced functionality in an intuitive format.

- It provides a quick start wizard, advanced system monitoring, complete parameter viewing and editing, fault diagnostics and optional control
- It is ideal for maintenance users who need easy-to-access local information with or without using a network or PC
- The user interface also has micro-USB port for connection to Power Xpert *inControl* for users who are not connecting over Modbus TCP

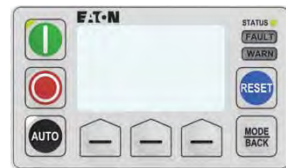

#### Ground Fault Module

The optional ground fault module can be used to detect zero sequence grounds on direct and high resistance grounded systems. The sensitivity between 30 mA and 10 A.



**Protection Summary** <sup>①</sup>

**Current-Based Protection Summary**

	Trip	Alarm	Trip Level Range	Default Level	Delay Range (Seconds)	Default Level (Seconds)	Alarm Level Range	Default Level	Delay Range (Seconds)	Default Level (Seconds)
Thermal overload	X	X	0.3–800 A	Low end of FLA range	Trip Class 5–40	Trip Class 5	1–100%	90%	Instantaneous	Instantaneous
Instantaneous overcurrent	X	X	50–400% FLA	400%	0.001–2.000	2	50–400% FLA	400%	0.2–5.0	2
Jam	X	X	50–400% FLA	400%	1–60	10	50–400% FLA	400%	0.2–5.0	2
Stall	X	—	50–400% FLA	200%	Instantaneous	Instantaneous	—	—	—	—
Undercurrent	X	X	10–90% FLA	50%	1–60	20	10–90% FLA	50%	0.2–5.0	2
Current unbalance	X	X	1–60%	15%	1–60	15	1–60%	15%	0.2–5.0	2
Current phase loss	X	—	60%	60%	2	2	—	—	—	—
Ground (earth) fault	X	X	②	②	1–60	5	②	②	0.2–5.0	2
PTC (requires option)	X	X	Overtemperature Shorted Open	OFF	—	—	Overtemperature Shorted Open	OFF	—	—

**Voltage-Based Protection Summary** <sup>③</sup>

	Trip	Alarm	Trip Level Range	Default Level	Delay Range (Seconds)	Default Level (Seconds)	Alarm Level Range	Default Level	Delay Range (Seconds)	Default Level (Seconds)
Phase rotation	X	—	ABC, ACB	ABC	Instantaneous	Instantaneous	—	—	—	—
Voltage phase loss	X	—	70%	70%	2	2	—	—	—	—
Overvoltage	X	X	90–150%	110%	1–60	20	90–150%	110%	0.2–5.0	2
Undervoltage	X	X	10–100%	90%	1–60	20	10–100%	90%	0.2–5.0	2
Voltage unbalance	X	X	2–20%	6%	1–20	20	1–20%	6%	0.2–5.0	2
Frequency deviation (slow)	X	X	0.1–5 Hz	0.1 Hz	1–60	20	0.1–5 Hz	0.1 Hz	0.2–5.0	2
Frequency deviation (fast)	X	X	0.02–2 Hz	0.1 Hz	0.02–60	1	0.02–2 Hz	0.1 Hz	0.2–5.0	2

**Power-Based Protection Summary** <sup>③</sup>

	Trip	Alarm	Trip Level Range	Default Level	Delay Range (Seconds)	Default Level (Seconds)	Alarm Level Range	Default Level	Delay Range (Seconds)	Default Level (Seconds)
Low power	X	X	–200 to 200%	50%	1–60	20	–200 to 200%	50%	1–60	2
High power	X	X	–200 to 200%	110%	1–60	20	–200 to 200%	110%	1–60	2
Power factor deviation (low)	X	X	–100 to 100%	0%	1–60	20	–100 to 100%	0	1–60	2
Power factor deviation (high)	X	X	–100 to 100%	100%	1–60	20	–100 to 100%	100%	1–60	2

**Advanced Protection Summary** <sup>③</sup>

	Trip	Alarm	Trip Level Range	Default Level	Delay Range (Seconds)	Default Level (Seconds)	Alarm Level Range	Default Level	Delay Range (Seconds)	Default Level (Seconds)
Voltage loss restart <sup>④</sup>	—	—	—	—	—	—	—	—	—	—
Peak demand alarm	—	X	User settable <sup>⑤</sup>	—	—	—	—	—	—	—

**Notes**

- ① Not all trips/alarms are enabled by default. Consult C445 user manual for further information.
- ② Sensing level depends on Measurement Module frame size and amperage range. Consult C445 user manual for further information.
- ③ Voltage, Power and Advanced Protections require voltage option on the measurement module.
- ④ Voltage loss restart is a control functionality used for reacceleration schemes after power loss. Consult C445 user manual for further information.
- ⑤ Consult C445 user manual for further information.

## Monitoring Summary

### Current-Based Monitoring

Parameter Name	Range / Units	Description
IA (L1) float	Depends on frame size (amps)	Phase A (L1) motor current; 2% accuracy within 30–125% of FLA
IB (L2) float	Depends on frame size (amps)	Phase B (L2) motor current; 2% accuracy within 30–125% of FLA
IC (L3) float	Depends on frame size (amps)	Phase C (L3) motor current; 2% accuracy within 30–125% of FLA
I Average float	Depends on frame size (amps)	Average motor current; 2% accuracy within 30–125% of FLA
I Unbalance percent	0–100%	Motor current unbalance percent
I Average % of FLA (nominal current)	0–720% of FLA (amps)	Average motor current as a percentage of FLA
Maximum start current floating point	Depends on frame size (amps)	Maximum motor starting current
Motor residual GF RMS	Depends on frame size (amps), scaled via fieldbus	Motor residual ground fault current RMS; Accuracy meets UL 1053 / IEC Class II-B

### Voltage-Based Monitoring <sup>①</sup>

Parameter Name	Range / Units	Description
Voltage AB (L1-L2)	0–690 V; max. 4,160 V with PT ratios	Supply line-to-line voltage AB (L1-L2); 2% accuracy up to 690 Vac
Voltage BC (L2-L3)	0–690 V; max. 4,160 V with PT ratios	Supply line-to-line voltage BC (L2-L3); 2% accuracy up to 690 Vac
Voltage CA (L3-L1)	0–690 V; max. 4,160 V with PT ratios	Supply line-to-line voltage CA (L3-L1); 2% accuracy up to 690 Vac
Average line-to-line voltage	0–690 V; max. 4,160 V with PT ratios	Supply line-to-line voltage average; 2% accuracy up to 690 Vac
Line frequency x 100	20–80 Hz (Centi-Hz)	Supply Frequency in centi-Hz
Voltage phase order	0: unknown; 1: ABC (L1-L2-L3); 2: ACB (L1-L3-L2)	Reports phase sequence of the line voltage
Voltage unbalance percent	0–100%	Supply voltage unbalance percentage

### Power-Based Monitoring <sup>①</sup>

Parameter Name	Range / Units	Description
Total watts	Depends on frame size (Watts)	Total Real Power; 5% accuracy
Total VA	Depends on frame size (Volt-Amps)	Total Apparent Power; 5% accuracy
Total VARs	Depends on frame size (VARs)	Total Reactive Power; 5% accuracy
Power factor	0–100%, Scaled by 0.01% via fieldbus	Apparent power factor in percentage; 1% accuracy
Motor speed RPM	Depends on motor (RPM)	Motor speed in RPM
Motor torque	Depends on motor (Nm)	Motor torque
Motor efficiency percent	PC Tool in %, Scaled by 0.01% via fieldbus	Motor efficiency in percentage
Real energy	Depends on frame size (0.1 kWh)	Real energy scaled; 5% accuracy
Real energy (resettable)	Depends on frame size (0.1 kWh)	Real energy (resettable) scaled; 5% accuracy
Apparent energy	Depends on frame size (0.1 kVAh)	Apparent energy scaled; 5% accuracy
Apparent energy (resettable)	Depends on frame size (0.1 kVAh)	Apparent energy (resettable) scaled; 5% accuracy
Reactive energy	Depends on frame size (0.1 kVARh)	Reactive energy scaled; 5% accuracy
Reactive energy (resettable)	Depends on frame size (0.1 kVARh)	Reactive energy (resettable) scaled; 5% accuracy
Current demand value	Depends on frame size (Watts)	Latest estimate of the demand; 5% accuracy
Demand (resettable)	Depends on frame size (Watts)	Peak demand, user resettable; 5% accuracy
Peak demand time stamp	Time in seconds	Peak demand time stamp (in Unix time)
Demand window duration	Time in minutes	Demand window duration

#### Note

<sup>①</sup> Voltage option must be selected for the measurement module.

**System Monitoring**

Parameter Name	Range / Units	Description
Motor state (current based)	0: Stopped; 1: Accelerating; 2: Running	Current Based motor state (independent of command)
Motor control status	Various	Present motor control status bits
Number of operating seconds	Time in seconds	Number of operating seconds
Operating seconds (resettable)	Time in seconds	Number of operating seconds (resettable)
Time to trip overload	Time in seconds	Time for overload to reach trip threshold (100%)
Time to reset overload	Time in seconds	Time for overload to reach reset threshold (thermal memory must drop below 75%)
PTC status	Various	PTC status
Digital input status	0/1	ON/OFF status of digital inputs
Base control module relay status	0/1	Base control module relay status (output status)
Total motor run time	Time in seconds	Total motor run time in seconds
Total motor run time (resettable)	Time in seconds	Total run time user (resettable)
Last measured starting time	Time in seconds	The amount of time the motor took to reach up to speed on the last start.
Number of starts	Number	Total number of motor starts
Number of starts (resettable)	Number	Number of starts (resettable)
Number of contactor operations last hour	Number	Number of contactor operations during the last hour
Latest run time	Time in seconds	Duration in seconds of the last start-to-stop motor run time
Thermal memory percent	0–250%	Thermal memory in percent—overload trip occurs at 100%

**Faults and Events**

Parameter Name	Range / Units	Description
Active fault	Various	Provides reason for trip
Active warning	Various	Provides reason for warning
Active inhibit	Various	Provides reason for inhibit
Fault queue—event order	Various	A list of the last 10 faults shown in the order they occurred. Most recent at top
Trip snapshot	Various	Time-stamp log of (12) parameters at time of trip

**Ground Faults**

Parameter Name	Range / Units
Pulse detection	1 to 8 A pulse
Zero sequence	30 mA to 10 A
High resistance ground	30 mA to 10 A



**Advanced Protection Education****Motor-Based Protections**

Definition	Source	Result	Power Xpert C445 Protection
<b>Thermal Overload</b>			
Overload is a condition in which current draw to a motor exceeds 115% of the full load amperage rating over a period of time for an inductive motor.	An increase in the load or torque that is being driven by the motor. A low voltage supply to the motor would cause the current to go high to maintain the power needed. A poor power factor would cause above normal current draw.	Increase in current draw. Current leads to heat and insulation breakdown, which can cause system failure. Additionally, an increase in current can increase power consumption and waste valuable energy.	Thermal trip behavior is defined by UL, CSA and IEC standards. Trip class is settable from 5–40 by 1. Provides power factor monitoring and low voltage protection features.
<b>Jam</b>			
Jam is similar to thermal overload in that it is a current draw on the motor above normal operating conditions.	Mechanical stall, interference, jam or seizure of the motor or motor load.	The motor attempts to drive the load, which has more resistive force due to the mechanical interference. In order to drive the load, the motor draws an abnormal amount of current, which can lead to insulation breakdown and system failure.	Provides a configurable Jam setting that is active during “motor run state” to avoid nuisance trips. Trip Threshold 50–400% of FLA. Trip Delay 1–20 seconds.
<b>Ground Fault</b>			
A line to ground fault.	A current leakage path to ground.	An undetected ground fault can burn through multiple insulation windings, ultimately leading to motor failure.	The C445 has three methods for detecting ground fault. 1) Residual current ground fault function is part of the original design for the C445. 2) Pulse ground fault detection function works with a system that has a pulser installed and can detect pulses from 1 to 8 A. 3) Zero sequence—this uses the C445XG-MOD and CTs to detect a ground fault that occurs on a high resistance ground or direct connected ground. This system will detect ground currents between 30 mA and 10 A.
<b>Imbalanced Phases (voltage and current)</b>			
Uneven voltage or currents between phases in a three-phase system.	When a three-phase load is powered with a poor quality line, the voltage per phase may be imbalanced.	Imbalanced voltage causes large imbalanced currents and as a result this can lead to motor stator windings being overloaded, causing excessive heating, reduced motor efficiency and reduced insulation life.	Provides two protection settings that address this problem. The user can choose to set current imbalance thresholds or voltage imbalance thresholds, each of which can trip the starter. Additionally, both of these may be monitored through C445's advanced monitoring capabilities, allowing the customer to notice in real-time when and where a condition is present.
<b>Phase Loss—Current (single-phasing)</b>			
One of the three-phase current is not present.	Multiple causes, loose wire, improper wiring, grounded phase, open fuse, and so on.	Single-phasing can lead to unwanted motor vibrations in addition to the results of imbalanced phases as listed above.	Fixed protective setting that takes the starter offline if a phase drops below 60% of the other two phases.
<b>Phase Rotation (phase-reversal)</b>			
Improper wiring, leading to phases being connected to the motor improperly.	A miswired motor. Inadvertent phase-reversal by the utility.	Phase-reversal can cause unwanted directional rotation of a motor. In the event that the load attached to the motor can only be driven in one direction, the result could be significant mechanical failure and/or injury to an operator.	Configurable phase protection, allowing the user to define the phase sequencing intended for that application. If no phase sequence is required, the user has the ability to disable this feature.
<b>Frequency Variance</b>			
When line frequency is inconsistent.	Malfunctioning alternator speed regulator, or poor line quality caused by an overload of a supply powered by individual sources.	Variations in frequency can cause increases in losses, decreasing the efficiency of the motor. In addition, this can result in interference with synchronous devices.	Advanced monitoring capabilities allow the user to monitor frequency in real time. Users can also optionally set an alarm or trip threshold for frequency variations from 70–110%.

### Load-Based Protections

Definition	Source	Result	Power Xpert C445 Protection
<b>Under Current or Low Power</b>			
Average rms current provided to the motor falls below normal operating conditions.	Under current is usually associated with a portion of the user's load disappearing. Examples of this would be a broken belt, a dry-pump (low suction head) or a dead-headed centrifugal pump.	If under current goes undetected, a mechanical failure can and has occurred. In the case of a pump, running a pump dry or running a pump in a dead-headed condition can cause excessive heating, damaging expensive seals and breaking down desired fluid properties.	C445 has two protection settings to detect this: under current and low power. Low power is a more consistent way of ensuring detection as power is linear with motor load, where as current is not. An unloaded motor may draw 50% of its rated current, but the power draw will be less than 10% of rated power due to a low power factor.
<b>High Power</b>			
The motor load is drawing more power than it should at normal operating conditions.	This is typical of batch processing applications where several ingredients flow into a mixer. When a substance's consistency changes and viscosity increases from what is expected, the motor may use more power to blend the mixture. Out-of-tolerance conditions can be detected using the High Power and Low Power settings.	If a high-power fault goes undetected, the result may be a batch of material that does not meet specification.	Monitors the three-phase real power. If the real power value is estimated above the set threshold for the set length of time, a fault is detected and the overload will trip the starter. Additionally, power can be monitored in real-time.

### Line-Based Protections

Definition	Source	Result	Power Xpert C445 Protection
<b>Overvoltage</b>			
When the line voltage to the motor exceeds the specified rating.	Poor line quality.	An overvoltage condition leads to a lower than rated current draw and a poor power factor. A trip limit of 110% of rated voltage is recommended. Over voltage can also lead to exceeding insulation ratings.	Monitors the maximum rms value of the three-phase voltages. If the rms value rises above the set threshold for the set length of time, a fault is detected and the overload can trip the starter or send and display an alarm of the condition. All line-related faults have an "alarm-no-trip" mode.
<b>Undervoltage</b>			
When the line voltage to the motor is below the specified rating.	Poor line quality.	An undervoltage condition leads to excessive current draw. This increases the heating of the motor windings and can shorten insulation life. A trip limit set to 90% of rated voltage is recommended.	Monitors the minimum rms value of the three-phase voltages. If the rms value drops below the set threshold for the set length of time, a fault is detected and the overload can trip the starter or send and display an alarm of the condition. All line-related faults have an "alarm-no-trip" mode.

### Catalog Number Selection

Build your system based on parts list below. C445 offers flexible options that can be combined to build your ideal system. Common combinations are stocked and others can be custom built if needed. Stock statuses are included below (note, this can change over time with usage—always contact EatonCare or refer to Vista for the latest stock information).

#### C445 System Parts

Part Description	Part Number	Required?	Notes
Base control module	<b>C445B...</b>	Required	System protection
Measurement module	<b>C445M...</b>	Required	System measurement
Connection cable 1	<b>D77E-QPIP...</b>	Required	Connects C445B... to C445M...
User interface	<b>C445U...</b>	Optional	Remote-mount control, diagnostics, monitoring
Connection cable 2	<b>D77E-QPIP...</b>	Depends <sup>①</sup>	Connects C445B... to C445U...
Communication card	<b>C445XC...</b>	Optional	PROFIBUS, EtherNet/IP, Modbus TCP
RTC/memory backup module	<b>C445XO-RTC</b>	Optional	Time stamping and configuration backup
USB programming cable	<b>C445XS-USBMICRO</b>	Optional	Power Xpert <i>in</i> Control USB cable (not needed when using Modbus TCP)
External CTs (3)	<b>XCT...</b>	Depends <sup>②</sup>	For systems greater than 136 A up to 800 A
Ground fault module	<b>C445XG-MOD</b>	Optional	Ground fault module to be used with C445XG-CT...
Zero sequence CT	<b>C445XG-CT...</b>	Optional	Zero sequence CT must be used with C445S

#### Notes

- <sup>①</sup> Required if using user interface.
- <sup>②</sup> Required for systems >136 A.

# 5.4

## Motor Protection and Monitoring

### Overload Relays

#### Relay

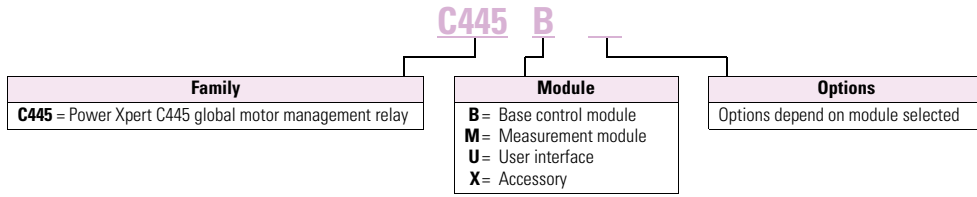

#### 5 Base Control Module

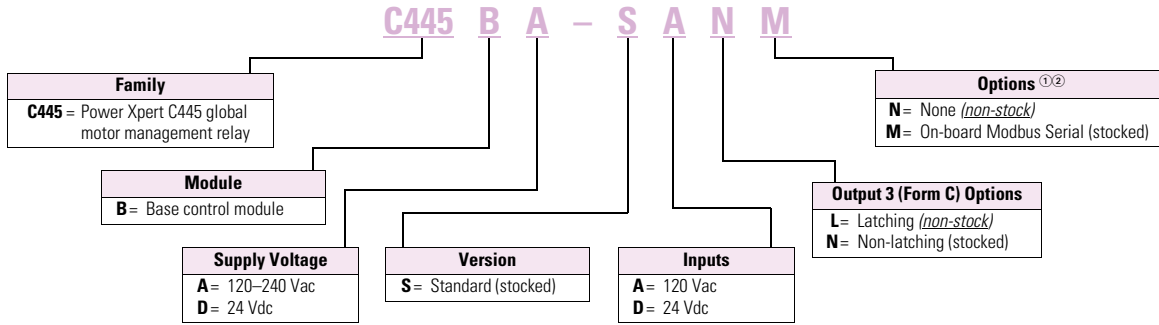

#### Measurement Module

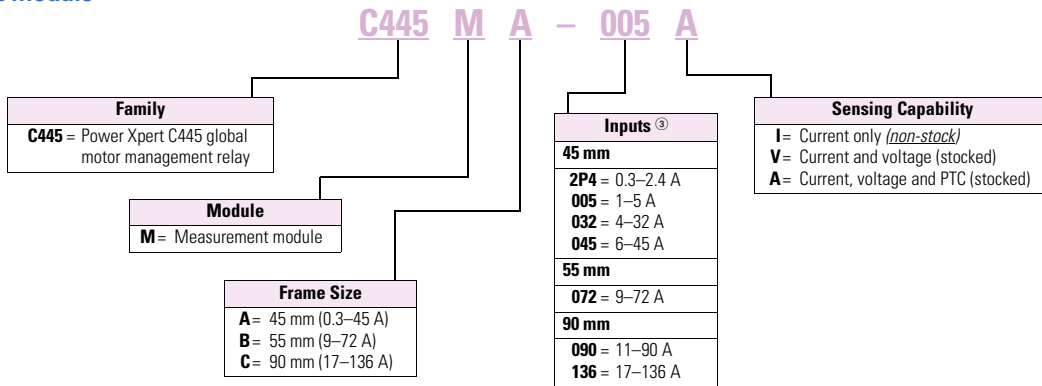

#### User Interface

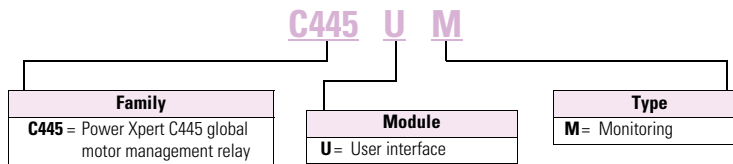

#### Notes

- ① For other communication protocol options, see Accessories chart on **Page V5-T5-99**.
- ② If a real-time clock and memory backup module are required, see Accessories chart on **Page V5-T5-99**.
- ③ For applications above 136 A, see Accessories chart on **Page V5-T5-99**.

**Power Xpert C445 Global Motor Management Relay**

**Accessories**

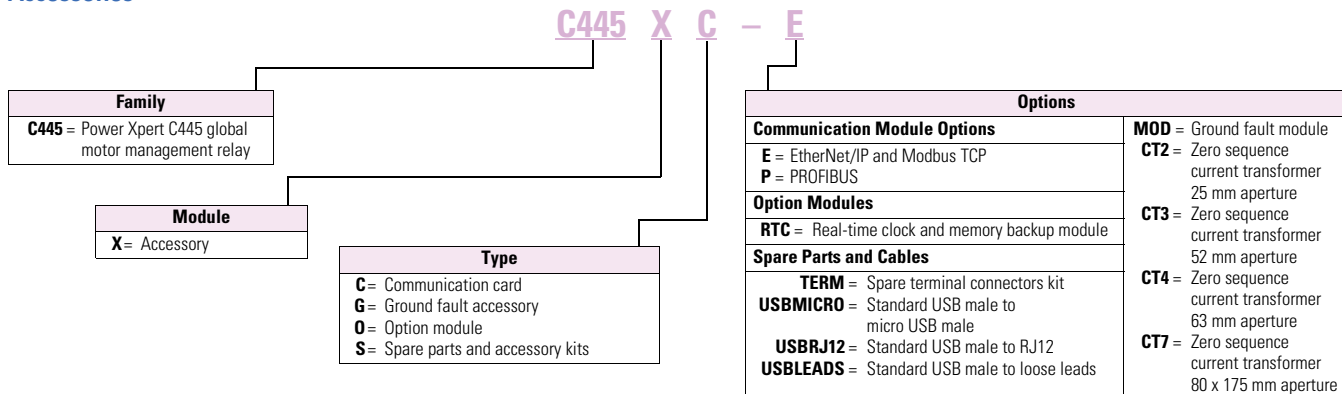

**Product Selection**

**Power Xpert C445 Global Motor Management Relay—Stocked Catalog Numbers**

**C445B\_**

**Base Control Module**



Power Source	Voltage Range ②	Digital Inputs	Relay Outputs	On-board Communications	Catalog Number
120/240 Vac	0–690 Vac	(4) 120 Vac	(2) Form A, (1) Form C (non-latching)	Modbus Serial	<b>C445BA-SANM</b>
		(4) 24 Vdc	(2) Form A, (1) Form C (non-latching)	Modbus Serial	<b>C445BA-SDNM</b>
24 Vdc	0–690 Vac	(4) 24 Vdc	(2) Form A, (1) Form C (non-latching)	Modbus Serial	<b>C445BD-SDNM</b>



**C445M\_**

**Measurement Module**



Frame Size	Current Range (A)	Current (I) Sensing	Voltage (V) Sensing	PTC Sensing	Catalog Number
45 mm	0.3–2.4	Yes	Yes	—	<b>C445MA-2P4V</b>
		Yes	Yes	Yes	<b>C445MA-2P4A</b>
	1–5	Yes	Yes	—	<b>C445MA-005V</b>
		Yes	Yes	Yes	<b>C445MA-005A</b>
	4–32	Yes	Yes	—	<b>C445MA-032V</b>
		Yes	Yes	Yes	<b>C445MA-032A</b>
55 mm	6–45 ③	Yes	Yes	—	<b>C445MA-045V</b>
		Yes	Yes	Yes	<b>C445MA-045A</b>
	9–72	Yes	Yes	—	<b>C445MB-072V</b>
		Yes	Yes	Yes	<b>C445MB-072A</b>
90 mm	11–90	Yes	Yes	—	<b>C445MC-090V</b>
		Yes	Yes	Yes	<b>C445MC-090A</b>
	17–136	Yes	Yes	—	<b>C445MC-136V</b>
		Yes	Yes	Yes	<b>C445MC-136A</b>

**Notes**

- ① C445XX-P only.
- ② Can be used for 4160 Vac applications with PT ratios.
- ③ The 45 mm frame is capable of 6 AWG wire maximum with the exception of insulation types RHH, RHW and RHW-2. If these insulation types are being used, use the 55 mm frame.

#### Embedded Logic Engine and Expansion I/O

The C445 is designed to allow function block programming to increase the logic capability of the C445. This logic allows a user to continue the current process logic or use logic that is configured locally. The logic engine can access the control parameters and I/O of the C445. The logic engine will access external expansion I/O. The C445 allows digital input up to 64 and digital output up to 64, plus up to 8 analog I/O cards. The analog I/O includes thermal measurement input modules. The expansion I/O utilizes the Modbus 485 connection on the C445 and the ELC-CARS485 communications module to communicate to the expansion I/O.

The following Expansion Modules are available: Communication module ELC-CARS485 plus I/O modules.

5

#### ELC-EX Embedded Logic Engine and Expansion I/O



Power	Input Unit Point	Type	Output Unit Point	Type	Digital I/O Model
<b>Dimensions W x H x D (mm): 25.2 x 90 x 60</b>					
24 Vdc	8	120 Vac	0	—	ELC-EX08NNAN
	8	DC sink or source	0	—	ELC-EX08NNDN
	0		8	Relay	ELC-EX08NNNR
	0		8	Transistor	ELC-EX08NNNT
	0		6	High current relay	ELC-EX06NNNI
	4		4	Relay	ELC-EX08NNDR
	8		8		ELC-EX16NNDR
	4		4	Transistor	ELC-EX08NNDT
	8		8		ELC-EX16NNDT

Power	Input Unit Point	Type	Output Unit Point	Type	Analog I/O Model
<b>Dimensions W x H x D (mm): 25.2 x 90 x 60</b>					
24 Vdc	0	—	2	0 mA to +20 mA	ELC-AN02NANN
	0		4	0 V to +10 V	ELC-AN04NANN
	4	-20 mA to +20 mA	2		ELC-AN06AANN
	4	-10 V to +10 V	0	—	ELC-AN04ANNN
	4	Platinum temp.	0		ELC-PT04ANNN
	4	Thermocouple	0		ELC-TC04ANNN

### User Interface

Catalog Number: **C445UM**

### Features—powerful but simple

- Intuitive navigation
- Safe, remote mounting on panel door
- Large font current, voltage, power, thermal and system monitoring
- Simple Setup Wizard
- Easy parameter setting
- Fault/event notification with full description and diagnostics
- Bright fault and warning LEDs
- Control status LEDs indicate starting, running, stopped, inhibited, auto
- Password protection option
- LED color, control button and screen idle behavior customization
- USB-Micro connects to free Power Xpert *inControl* software



### Monitoring Menus: Press <MODE/BACK> to toggle through

	I (Current)	V (Voltage)	P (Power)	T (Thermal)	O (Other)
<b>Data in menu</b> Use ▲ to scroll	Avg Current (Iavg)	Watts Total (P Watts)	Thermal Memory % (TM%)	Run Time (Run Time)	# Motor starts (#Starts)
	Avg Voltage (Vavg)	Voltage Unbalance (VUnb)	Power Factor (PF)	Time to Reset (T to Rst)	Max Starting I (MaxStart)
	Iavg % of FLA (1%FLA)	Phase Order (Ph Ord)	VA Total (P VA)	Thermal Capacity % (TC%)	Last Start Time (LastStart)
	Current Unbalance (IUnb)	Voltage L1-L2 (L1-L2)	VARs Total (P VARs)	PTC state (PTC)	Frequency (Freq)
	Ground Fault Current (IGF)	Voltage L2-L3 (L2-L3)	Real Energy (P kWh)		RTC Time (RTC Time)
	I Phase A (IA)	Voltage L3-L1 (L3-L1)			IP Address (IP Addr)
	I Phase B (IB)				Operating Sec (Op Time)
I Phase C (IC)				Contactors Ops Last Hr (Ctr Ops)	
					Speed RPM (Speed)

### Program (PRG) Menu Groups

	Control	Wiring Config	Protections	User Interface Settings
<b>Go here to ...</b>	See active control source	Set single phase/3-phase	Enable/disable trips/warnings	Set screen idle behavior
	Control relay outputs	Set CT ratios	Customize protection thresholds and delays	Contrast/brightness
	View digital input status	Set PT ratios		Set control button delays
	View relay output status			Change LED colors
	Monitor	Operation Mode	Real Time Clock	Security
	Monitor voltage, current, power, system data (all monitoring values, not just favorites)	Select operation mode, local/remote control sources	Set time and time zone	Set passwords (local, admin, USB)
	Clear resettable monitor values	Set comm loss/idle behavior	Communications	Services
		Select output functions	Configure Ethernet and Modbus settings (addresses, baud rate, advanced, etc.)	Factory Reset
	Motor Configuration	Faults and Events	System View	Soft Reset
	Set/view motor nameplate data (also in Setup Wizard)	View active fault/warning/inhibit	View product details (serial number, firmware version, etc.)	Re-pair modules
		View or clear fault queue and trip snapshot		Launch Setup Wizard

### Note

① Resettable parameter—users can reset to zero in PRG menu.

#### Accessories

XCT\_



#### External Current Transformers

Use external CTs on systems greater than 136A with the 1–5 Amp Measurement Module (Part Numbers C445MA-005\_). Catalog numbers are for one single-phase CT. Order three CTs for a three-phase system.

CT Range (A)	Description	Terminal Size	Measurement Module	Catalog Number
17–300	300:5 single-phase CT, 1.25 inch dia hole, UL and CSA ANSI/IEEE C57.13, 50–400 Hz, 600 Vac, 10 kV, relay class C50, accuracy 0.3% B0.1	(2) 8–32 brass terminals, comes with mounting bracket kit	C445MA-005_	XCT300-5
75–600	600:5 single-phase CT, 2.00 inch dia hole, UL and CSA ANSI/IEEE C57.13, 50–400 Hz, 600 Vac, 10 kV, relay class C50, accuracy 0.3% B0.1	(2) 8–32 brass terminals, comes with mounting bracket kit	C445MA-005_	XCT600-5
100–800	800:5 single-phase CT, 2.50 inch dia hole, UL and CSA ANSI/IEEE C57.13, 50–400 Hz, 600 Vac, 10 kV, relay class C50, accuracy 0.3% B0.1	(2) 8–32 brass terminals, comes with mounting bracket kit	C445MA-005_	XCT800-5

C445X\_



#### Communication and Option Modules

Description	Catalog Number
EtherNet/IP and Modbus TCP card with 2-port switch	C445XC-E
PROFIBUS DPV0 and DVP1 card	C445XC-P
Real-time clock and memory backup module	C445XO-RTC
Ground fault module	C445XG-MOD

C445XG-MOD



C445XG-CT2

Zero sequence current transformer 25 mm aperture

C445XG-CT2



C445XG-CT3

Zero sequence current transformer 52 mm aperture

C445XG-CT3



C445XG-CT4

Zero sequence current transformer 63 mm aperture

C445XG-CT4



C445XG-CT7

Zero sequence current transformer 80 x 175 mm aperture

C445XG-CT7



**Cables, Wiring Harnesses and Spare Parts****Connection Cables and Accessories**

D77E connection cables are required to connect the base control module to the measurement module and to the user interface. Order the appropriate lengths for each connection.

C445XS-USBMICRO can be used to connect to Power Xpert *inControl* over USB if the Ethernet option is not used. C445XS-USBLEADS or C445XS-USBRJ12 are used for firmware updates.

Description	Catalog Number
Connection cable (base control module to measurement module or user interface), 13 cm length	<b>D77E-QPIP13</b>
Connection cable (base control module to measurement module or user interface), 25 cm length	<b>D77E-QPIP25</b>
Connection cable (base control module to measurement module or user interface), 100 cm length	<b>D77E-QPIP100</b>
Connection cable (base control module to measurement module or user interface), 200 cm length	<b>D77E-QPIP200</b>
Connection cable (base control module to measurement module or user interface), 300 cm length	<b>D77E-QPIP300</b>
Spare parts kit—terminal connectors, mounting feet	<b>C445XS-TERM</b>
Standard USB A male to micro USB male cable	<b>C445XS-USBMICRO</b>
Standard USB A male to loose leads cable (used with Modbus Serial terminal for firmware upgrades)	<b>C445XS-USBLEADS</b>
Standard USB A male to RJ-12 cable (for firmware upgrades)	<b>C445XS-USBRJ12</b>



#### Power Xpert inControl Software

The Power Xpert *inControl* software tool is designed for easy commissioning of Eaton control products such as Power Xpert C445 and the Power XL DG1 drive. While users may configure C445 locally with the monitoring user interface, *inControl* is a great tool for motor control centers with multiple devices as users may save and re-use configuration files. The easiest way to connect to Power Xpert *inControl* is over Modbus TCP (C445XC-E required). This option allows you to see all connected devices in one window via their IP address. Users without Ethernet may also connect directly to the C445 micro-USB port located on the user interface or base module using a USB-to-USB micro cable (C445XS-USBMICRO).

5

Power Xpert *inControl* is available for download free of charge at [www.eaton.com/C445](http://www.eaton.com/C445). Refer to Power Xpert *inControl* User Manual MN040013EN for more information.

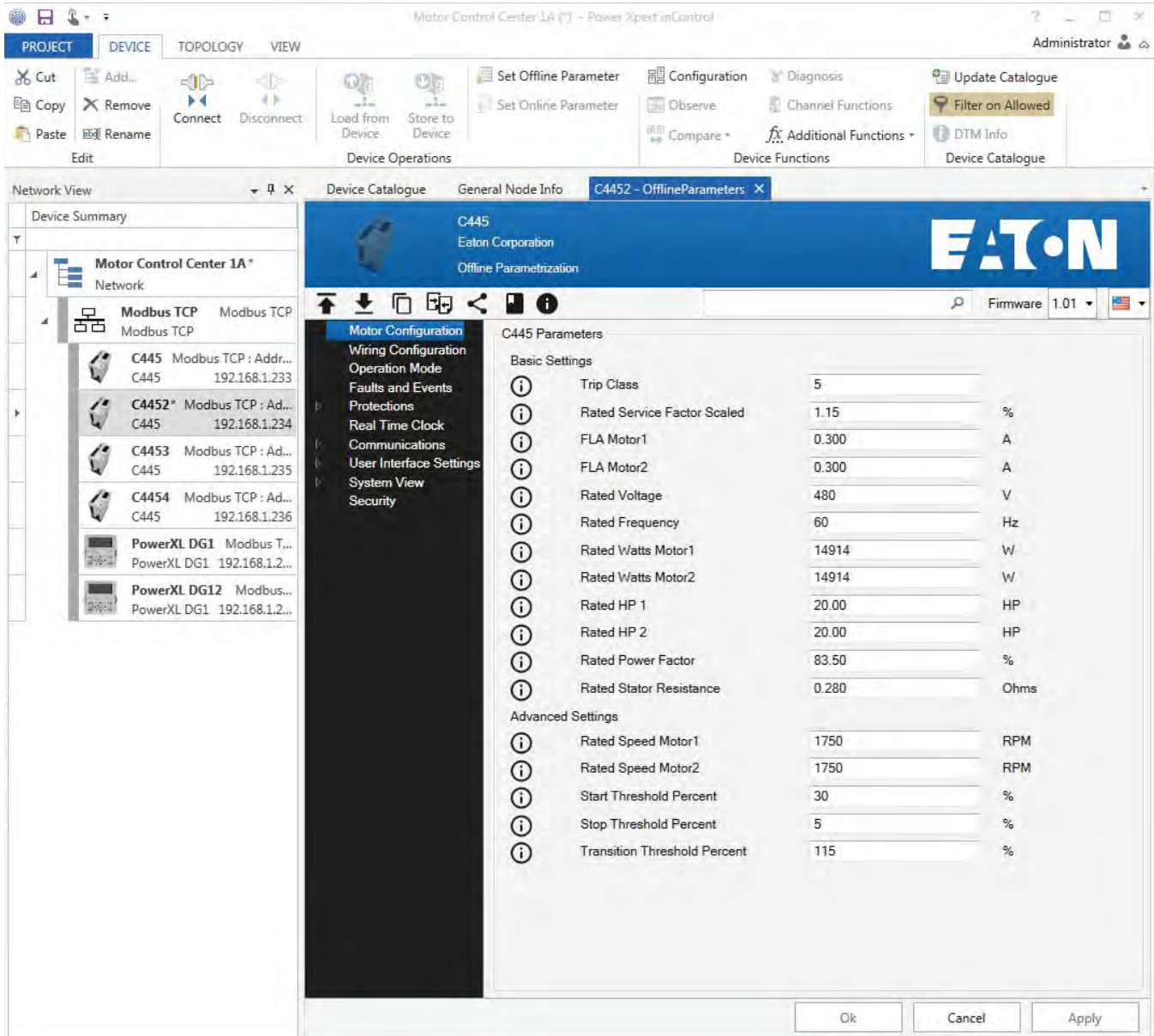

**Technical Data and Specifications**

**Power Xpert C445 Motor Management Relay Short Circuit Ratings (North American CSA and UL) ①**

Measurement Module Frame	Overload FLA Range	Standard-Fault Short Circuit Data				High-Fault Short Circuit Data			Thermal-Magnetic Circuit Breakers		
		480 V (kA)		600 V (kA)		Fuses (RK5)		Max. Fuse Size (A) (RK5)	480 V (kA)		Max. Breaker Size (A)
		480 V (kA)	600 V (kA)	Max. Fuse Size (A) (RK5)	Max. Breaker Size (A)	480 V (kA)	600 V (kA)	Max. Fuse Size (A) (RK5)	480 V (kA)	600 V (kA)	Max. Breaker Size (A)
45 mm	0.3–2.4 A	5	5	6 A	15 A	100	100	6 A	100	35	15 A
45 mm	1–5 A	5	5	20 A	20 A	100	100	20 A	100	35	20 A
45 mm	4–32 A	5	5	125 A	125 A	100	100	125 A	100	35	125 A
45 mm	6–45 A	5	5	175 A	175 A	100	100	175 A	100	35	175 A
55 mm	9–72 A	10	10	250 A	250 A	100	100	250 A	100	35	250 A
90 mm	11–90 A	10	10	360 A	360 A	100	100	360 A	100	50	360 A
90 mm	17–136 A	10	10	400 A	400 A	100	100	400 A	100	50	400 A

**Power Xpert C445 Motor Management Relay Short Circuit Ratings (IEC) ①**

Measurement Module Frame	Overload FLA Range	Standard-Fault Short Circuit Data					High-Fault Short Circuit Data			Thermal-Magnetic Circuit Breakers				
		480 V (kA)		690 V (kA)		Max. Fuse Size (A) (gG)	Max. Breaker Size (A) 480 V	Max. Breaker Size (A) 690 V	Fuses (gG)		480 V (kA)		Max. Breaker Size (A) 480 V	Max. Breaker Size (A) 690 V
		480 V (kA)	690 V (kA)	Max. Fuse Size (A) (gG)	Max. Breaker Size (A) 480 V	Max. Breaker Size (A) 690 V	480 V (kA)	690 V (kA)	Max. Fuse Size (A) (gG)	480 V (kA)	690 V (kA)	Max. Breaker Size (A) 480 V	Max. Breaker Size (A) 690 V	
45 mm	0.3–2.4 A	1	1	16 A	15 A	N/A	100	100	10 A	100	N/A	15 A	N/A	
45 mm	1–5 A	1	1	20 A	20 A	20 A	100	100	20 A	100	80	20 A	20 A	
45 mm	4–32 A	3	3	125 A	125 A	125 A	100	100	125 A	100	80	125 A	125 A	
45 mm	6–45 A	3	3	200 A	175 A	160 A	100	100	125 A	100	80	175 A	160 A	
55 mm	9–72 A	5	5	250 A	250 A	250 A	100	100	160 A	100	80	250 A	250 A	
90 mm	11–90 A	5	5	360 A	360 A	360 A	100	100	360 A	100	80	360 A	360 A	
90 mm	17–136 A	10	10	400 A	400 A	400 A	100	100	400 A	100	80	400 A	400 A	

**Power Xpert C445 Technical Data and Specifications**

Description	Specification
<b>Electrical, Motor/Load Ratings</b>	
Operating voltage	110–690 Vac 4160 Vac with Potential Transformer (PT) ratios between 35:1 and 6:1 (purchased separately) (PT)
Trip class	5–40, selectable in 5 step increments
Operating current (FLA) range	Varies by measurement module frame. See below.
45 mm measurement module	0.3–2.4 A; 1.0–5.0 A; 4.0–32.0 A; 6–45 A
55 mm measurement module	9.0–72.0 A
90 mm measurement module	11.0–90.0 A; 17.0–136.0 A
Rated frequency	47–63 Hz
Application(s)	Single-phase, three-phase
Accuracy	Current: 2% within 30–125% of FLA; 3% ≤ 500% of FLA Voltage: 2% within 110 Vac, 690 Vac Power: 5%
Rated supply voltage	120/240 Vac (or) 24 Vdc
Operating supply voltage range	94–264 Vac (or) 18–30 Vdc
Overvoltage category	24 Vdc = III 120/240 = II
Maximum power consumption	Less than 8 W—varies by module, see below
Base control module + measurement module	Less than 5 W
User interface	Less than 1.5 W
Communication card	Less than 2 W

**Note**

① Short circuit protective device (SCPD) sizing per NEC: Max = 400% of FLA under 100 A, 300% of FLA over 100 A.

## Power Xpert C445 Technical Data and Specifications, continued

Description	Specification
<b>Environmental Ratings</b>	
Ambient temperature (operating)	−40 to 60 °C (−40 to 140 °F)
Ambient temperature (storage)	−40 to 85 °C (−40 to 185 °F)
Operating humidity [UL991 (H3)]	5–95% noncondensing
Altitude NEMA ICS1	2000 meters (6600 feet)
Shock IEC 60068-2-27	15 g any direction for 11 milliseconds, non-operating
Vibration IEC 60068-2-6	5 g non-operating and 3 g operating in any direction
Pollution degree per IEC 60947-4-1	3
Ingress protection	IP20 (Base Control Module / Measurement Module) IP54 (User Interface)
Mean time between failures (MTBF)	20 years at 50 °C
<b>Safety</b>	
Thermal overload protection	Per UL 60947-4-1, IEC 60947-4-1
Binary PTC protection	IEC 60947-8
Safety integrity level	SIL 1 (reference 50495)
<b>Electrical / EMC</b>	
Radiated emissions IEC/EN 60947-4-1, Table 15 EN 55011 (CISPIR 11) Group 1, Class A	30–1000 MHz
Conducted emissions IEC/EN 60947-4-1, Table 14 EN 55011 (CISPIR 11) Group 1, Class A	0.15–30 MHz
ESD immunity per IEC 61000-4-2	± 8 kV air, ± 4 kV contact
Radiated immunity per IEC 61000-4-3	10 V/m 80–1000 MHz 80% amplitude modulation 1 kHz sine wave
Fast transient per IEC 61000-4-4	± 2 kV power ± 1 kV signals, data and control
Surge per IEC 61000-4-5	± 1 kV line-to-line ± 2 kV line-to-ground
Conducted immunity per IEC 61000-4-6	10 V, 0.15–80 MHz 80% amplitude modulation 1 kHz sine wave
Magnetic field per IEC 61000-4-8	30 A 50/60 Hz
Voltage dips per IEC 61000-4-11	Class 2, 110 Vac 60 Hz, 230 Vac 50 Hz 0% during 1/2 cycle 0% during 1 cycle 70% during 25/30 cycles  Note: 70% refers to 70% of nominal operating voltage, 0% refers to 0% of operating voltage, 25/30 cycles correlates to 50/60 Hz.
<b>Output Relay Ratings (Base Control Module)</b>	
Three mono-stable output relays One Form C (NO/NC) Two Form A (NO)	B300 pilot duty on all relays R300 pilot duty on NO relays only
Rated operating current	3 A at 120 Vac, 1.5 A at 240 Vac 1.5 A at 24 Vdc, 0.22 A at 125 Vdc, 0.1 A at 250 Vdc
Utilization category	AC-15; DC-13

**Power Xpert C445 Technical Data and Specifications, continued**

Description	Specification						
<b>Input Ratings (Base Control Module)</b>							
Supply voltage	24 Vdc	120 Vac					
Number of inputs	4	4					
Type of inputs	Digital	Digital					
On-state voltage	15–20 Vdc	79–132 Vac					
Off-state voltage	0–5 Vdc	0–30 Vac					
Oversvoltage category	III	II					
<b>Input/Output Terminal Blocks</b>							
Wire capacity	30–12 AWG ①						
Screw torque requirement	3.5–4.4 in-lb (0.4–0.5 Nm)						
<b>Measurement Module Current Pass Through</b>							
Measurement module size (current range)	45 mm (0.3–2.4 A)	45 mm (1–5 A)	45 mm (4–32 A)	45 mm (6–45 A)	55 mm (9–72 A)	90 mm (11–90 A)	90 mm (17–136 A)
Supported conductor							
NA 600 V (AWG)	6 AWG	6 AWG	6 AWG	6 AWG	3 AWG	2/0 AWG	2/0 AWG
EMEA 690 V (mm <sup>2</sup> )	16 mm <sup>2</sup>	16 mm <sup>2</sup>	16 mm <sup>2</sup>	16 mm <sup>2</sup>	25 mm <sup>2</sup>	70 mm <sup>2</sup>	70 mm <sup>2</sup>
<b>Voltage Terminals</b>							
Terminal screw torque requirement	3.5–4.4 in-lb (0.4–0.5 Nm)						
Maximum wire capacity (for voltage input terminals)	12–26 AWG solid 0.13 to 3.31 mm <sup>2</sup>						

**PTC Specifications**

Description	Specification
Standard	EN 60947-8/A1:2006 "Mark A Control Unit"
Compatible thermal detectors	Mark A type (abrupt characteristic change) as described in EN 60947-8/A1:2006 Annex A wired in series
Terminals	Marked T1 and T2 12–30 AWG solid (0.13–4 mm <sup>2</sup> )
Cold resistance	≤1500 ohms
Measuring voltage	≤2.5 V for resistance ≤1330 ohms ≤7.5 V for resistance ≤4 kohms ≤9.0 V open circuit
Temperature rise response	3600 ohms ±10%
Over temperature reset	1500 ohms ±10%
Short-circuit response	Between 10 and 20 ohms
Short-circuit reset	Between 20 and 40 ohms
Wire break response	20 k to 40 kohms
Isolation	U <sub>imp</sub> = 4 kV

**Ground Fault Module and Current Transformer Specifications**

Description	Specification
<b>Environmental Rating</b>	
Operating temperature	–40 to 70 °C
Humidity	5–95% noncondensing
Vibration	3 G
Shock	15 G
<b>Electrical Rating</b>	
CT ratio	500:01:00
Current range	30 mA to 10 A
Nominal system voltage	690 Vac
Frequency	50/60 Hz
Accuracy	1% with 1.5 ohm burden

**Note**

① Use only UL Listed or recognized conductors. Copper wire rated 75C for all field wiring terminals and main conductor wiring.

# 5.4

## Motor Protection and Monitoring

### Overload Relays

#### Dimensions

##### Power Xpert C445 Motor Management Relay

Approximate Dimensions in Inches (mm)

#### Base Control Module

5

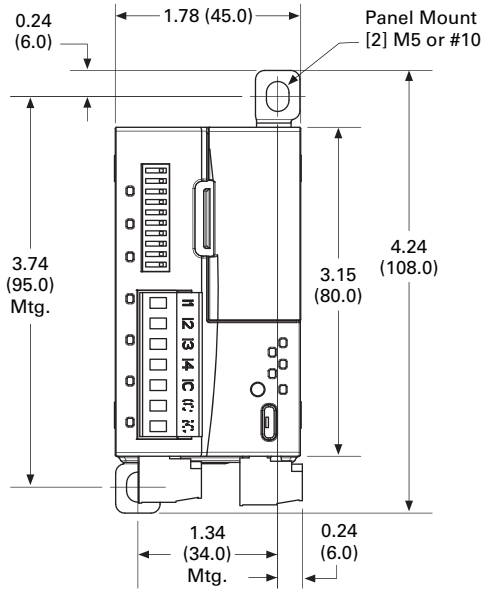
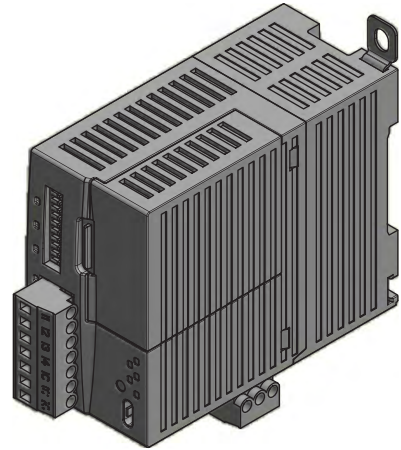

**Panel Mount  
Option 1**

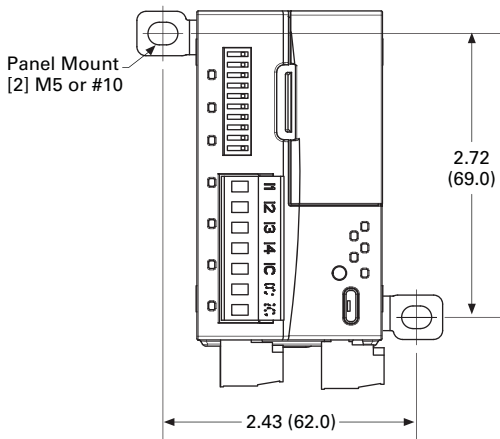

**Panel Mount  
Option 2**

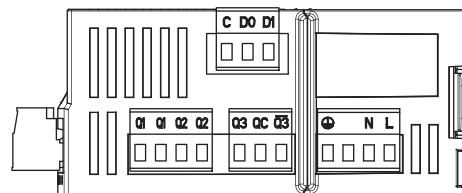
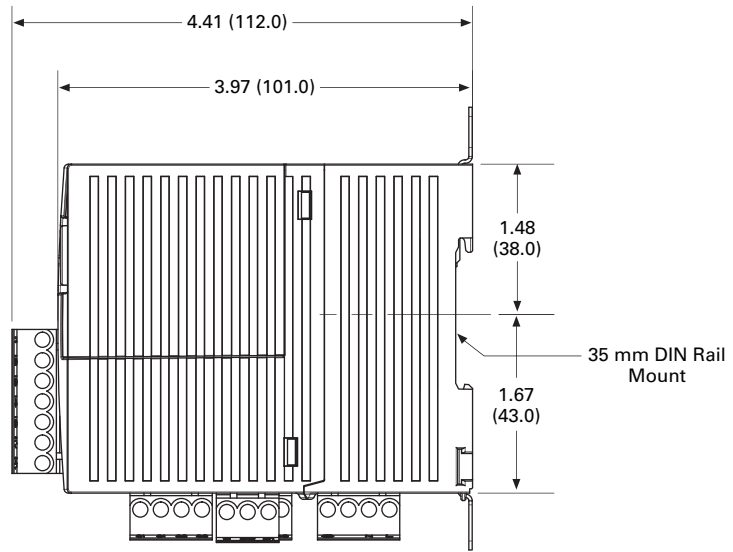

Approximate Dimensions in Inches (mm)

Measurement Module—45 mm Frame

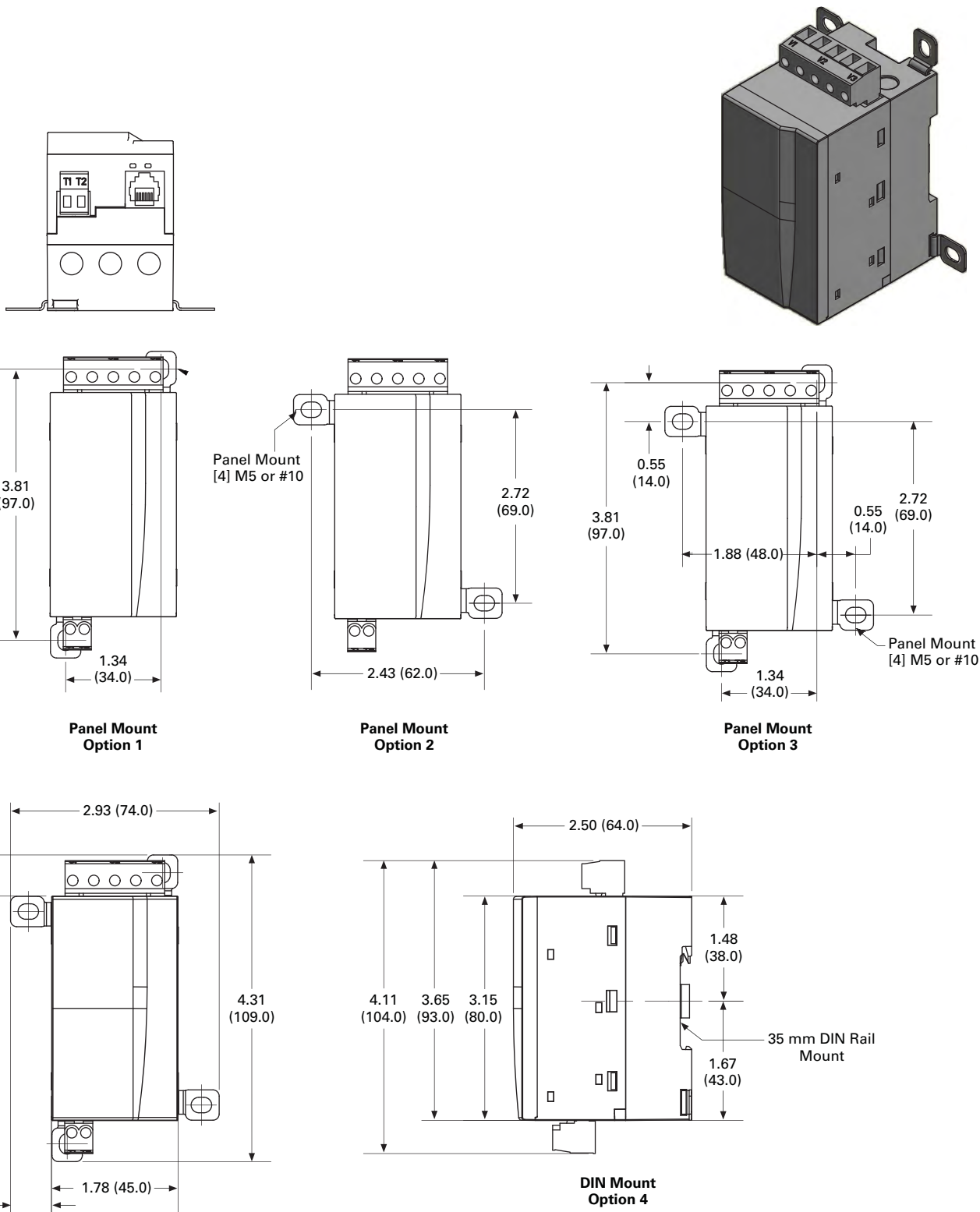

**Note:** Measurement Module part shown has factory-installed terminals for all measurement options (current, voltage and PTC).

# 5.4

## Motor Protection and Monitoring

### Overload Relays

Approximate Dimensions in Inches (mm)

#### Stacked Mounting of Base Control Module and 45 mm Frame Measurement Module

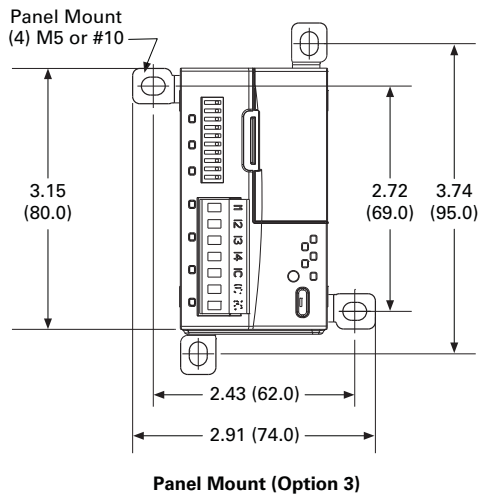
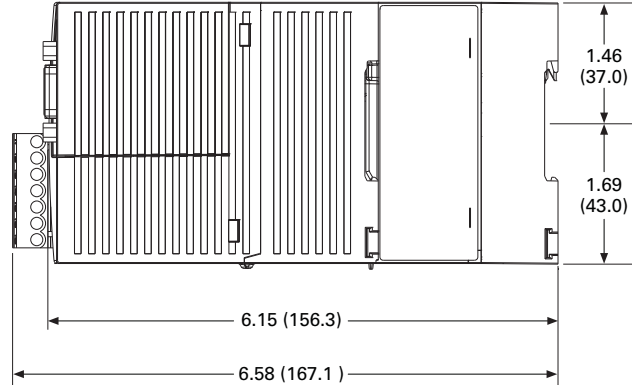
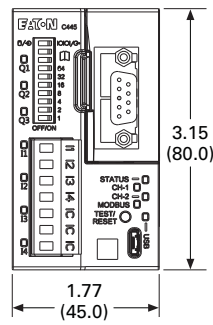

Approximate Dimensions in Inches (mm)

Measurement Module—55 mm Frame

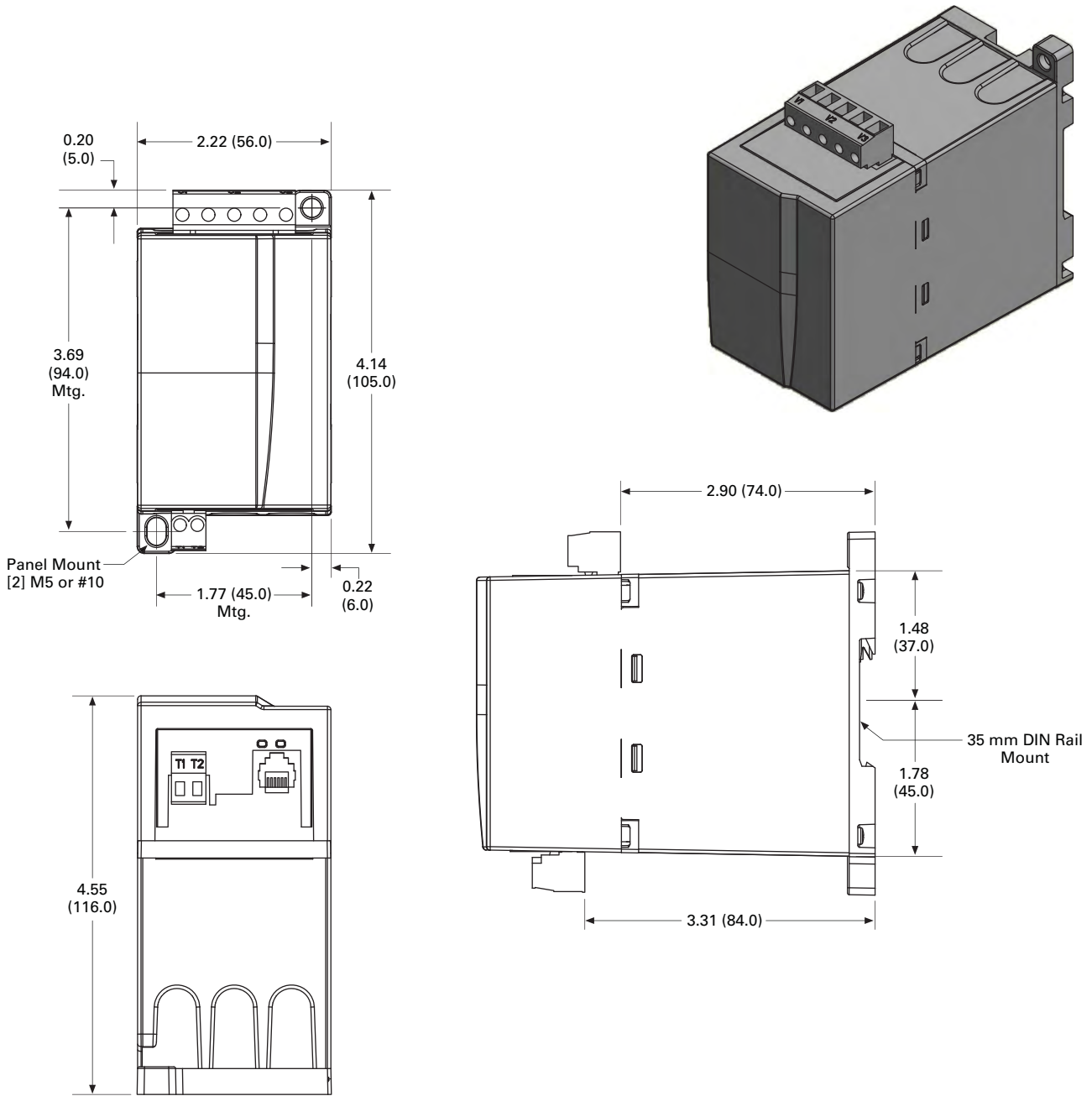

**Note:** Measurement Module part shown has factory-installed terminals for all measurement options (current, voltage and PTC).



# 5.4

## Motor Protection and Monitoring

### Overload Relays

Approximate Dimensions in Inches (mm)

#### Measurement Module—90 mm Frame

5

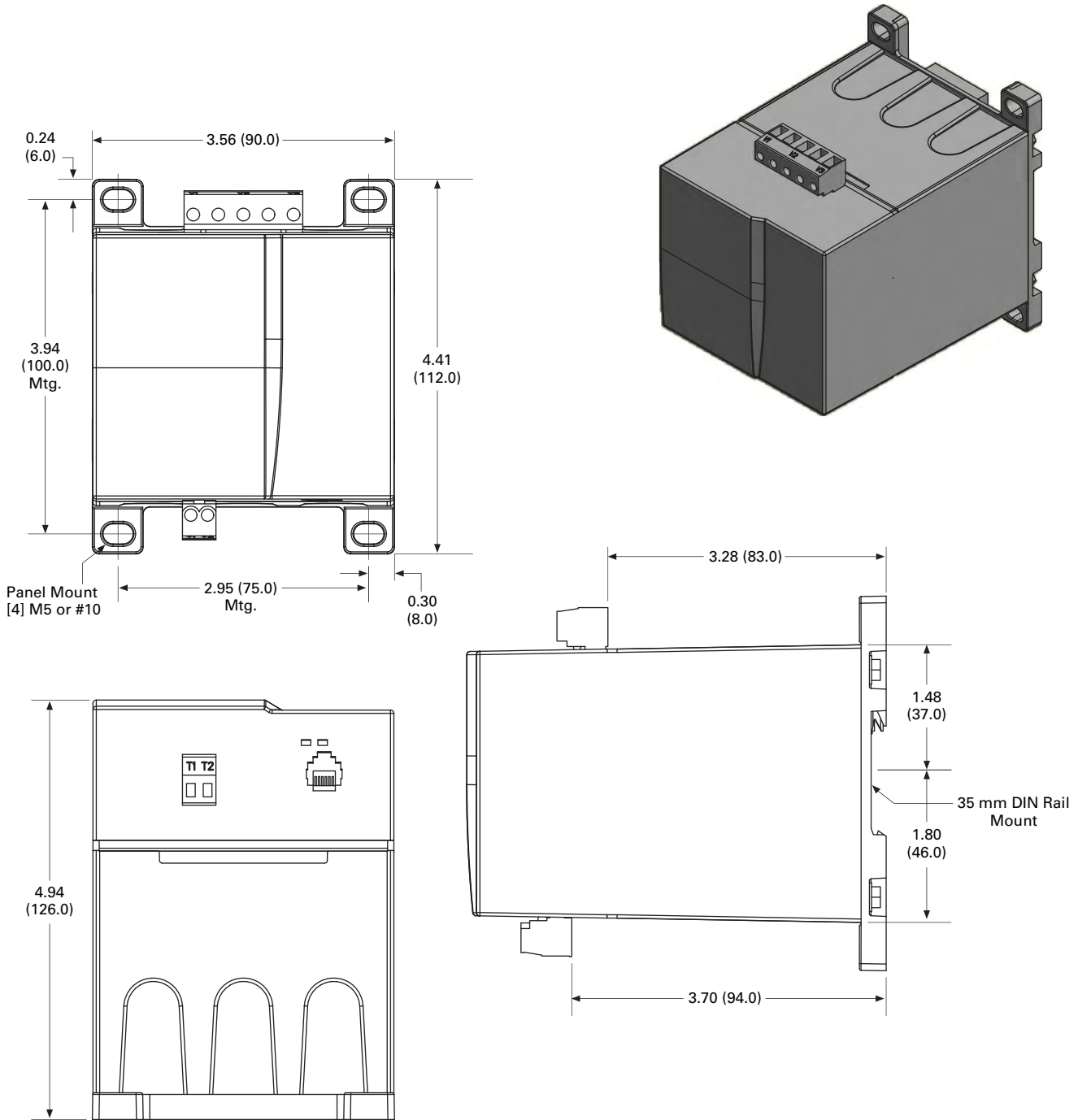

**Note:** Measurement Module part shown has factory-installed terminals for all measurement options (current, voltage and PTC).

Approximate Dimensions in Inches (mm)

### User Interface—Monitoring Version

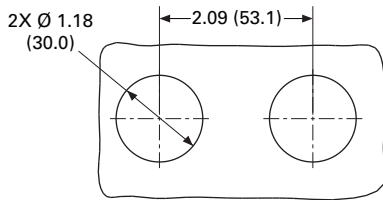

Option 1

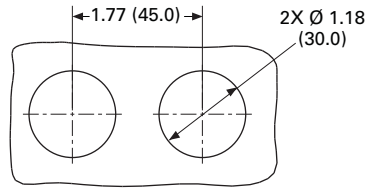

Option 2

**Note:** Backwards compatible with C4411 Motor Insight display cutout.

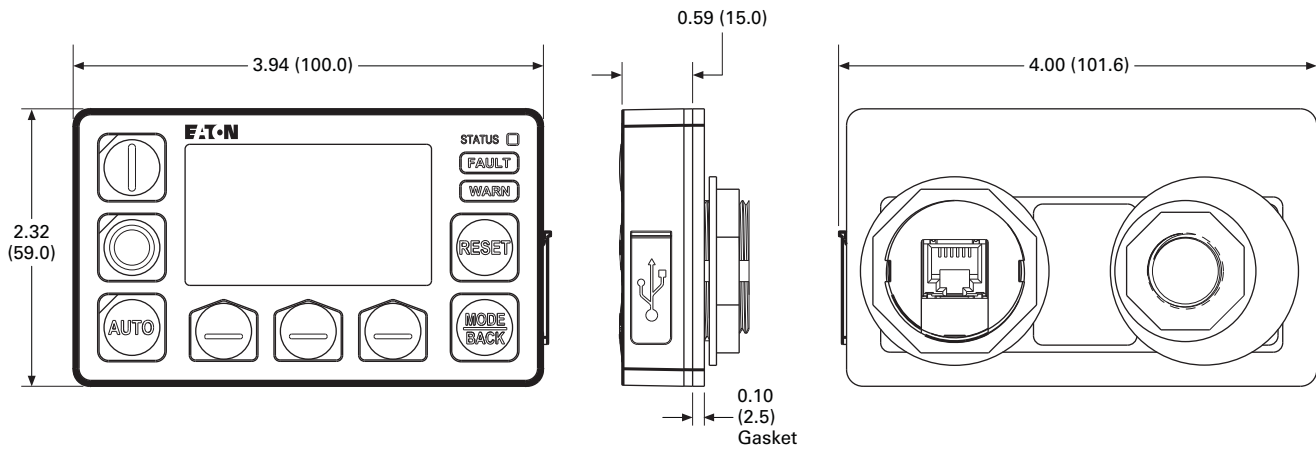
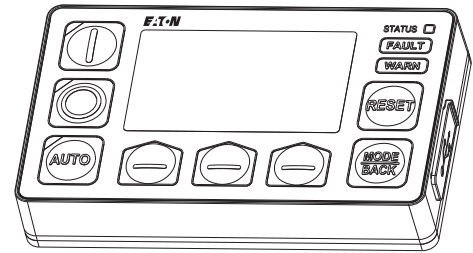

# 5.4

## Motor Protection and Monitoring

### Overload Relays

#### Grounding Faults

Approximate Dimensions in Inches (mm)

#### C445XG-MOD

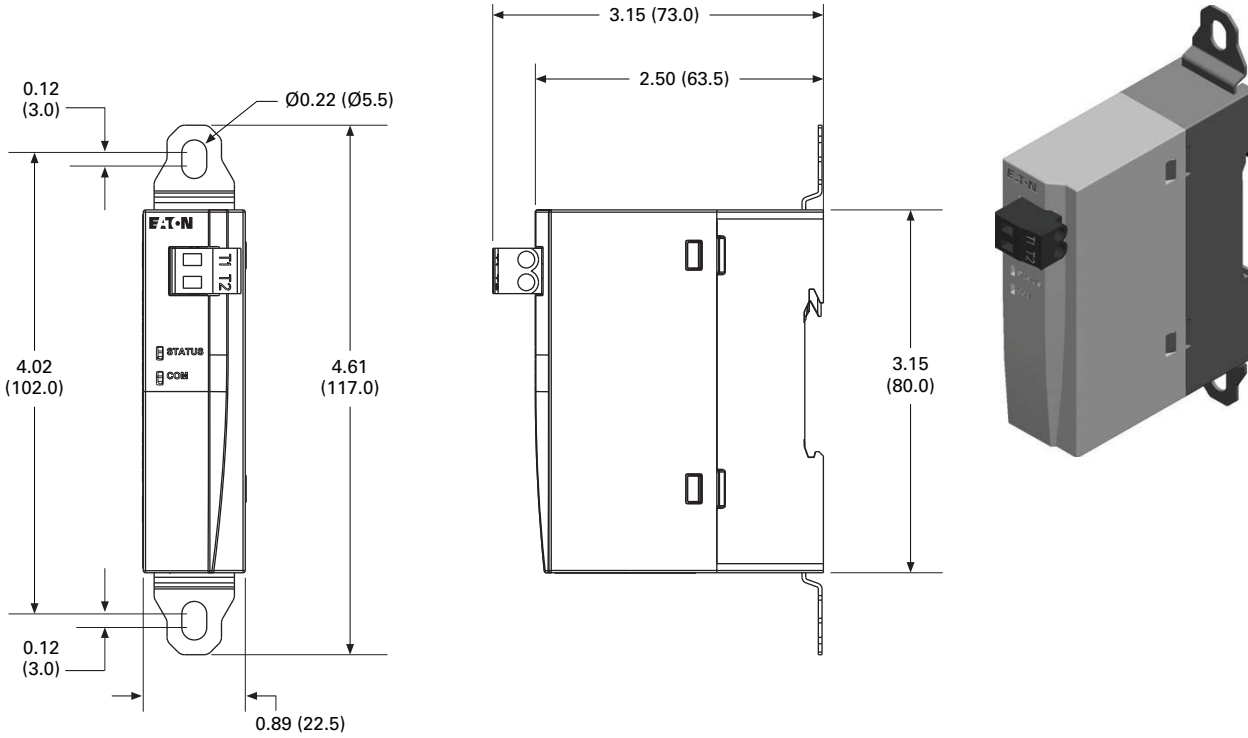

#### C445XG-CT2

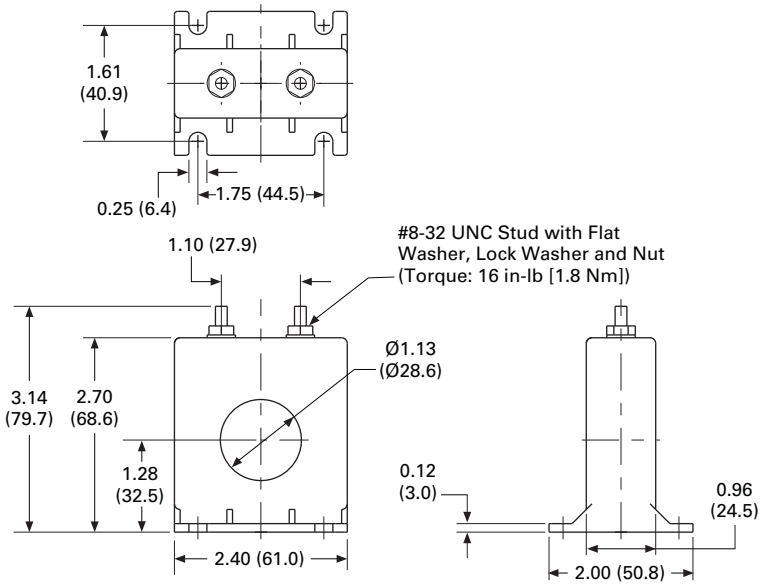

Approximate Dimensions in Inches (mm)

### C445XG-CT3

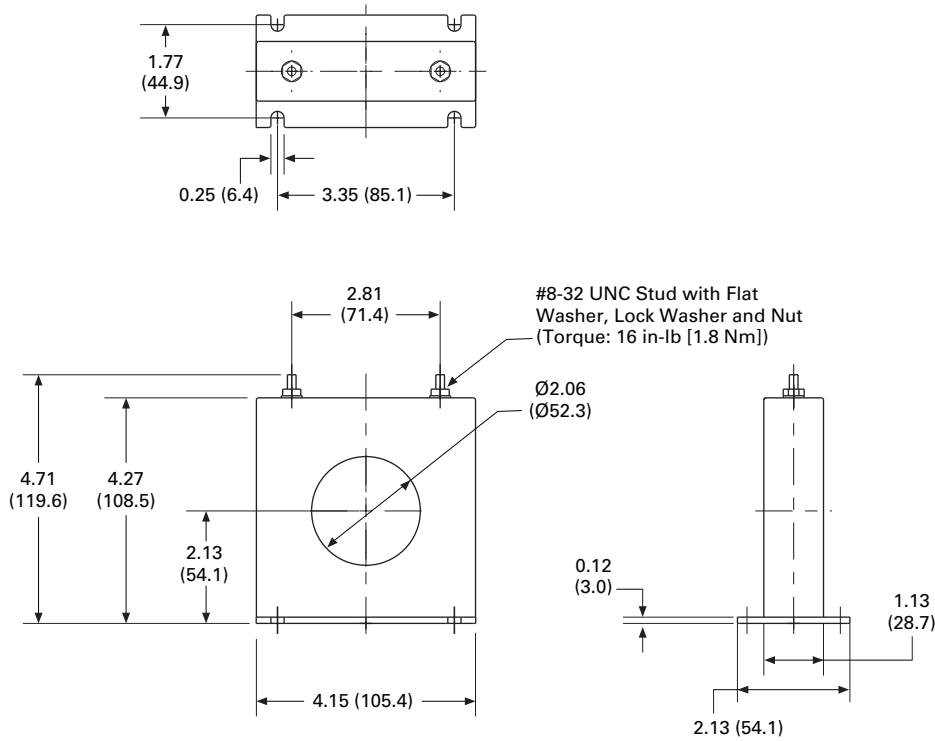

### C445XG-CT4

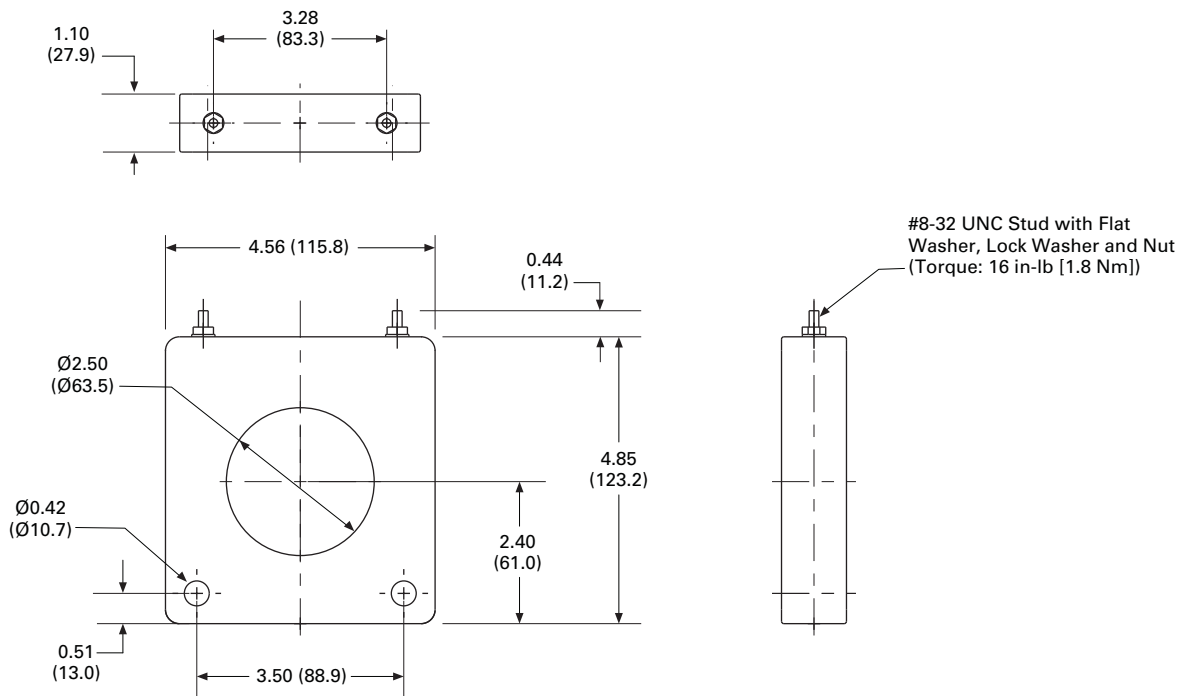

# 5.4

## Motor Protection and Monitoring

### Overload Relays

Approximate Dimensions in Inches (mm)

**C445XG-CT7**

