

Instructions for Type ME Contactors and Type L46 or Type L66 Auxiliary Contacts Rated 600 Volts DC, Maximum

TYPE ME CONTACTORS

Each Type ME contactor is a front-connected industrial contactor rated for DC applications up to 600 volts. They are available in several configurations.

This industrial type control is designed to be installed, operated, and maintained by adequately trained workmen. These instructions do not cover all details, variations, or combinations of the equipment, its storage, delivery, installation, checkout, safe operation, or maintenance. Care must be exercised to comply with local, state, and national regulations, as well as safety practices for this class of equipment.

Each structure has a 150 ampere DC continuous rating, but to match the contactor to the load for maximum contact life, a contactor is supplied with either a 10, 25, 50, 100, or 150 ampere blowout coil from the factory. In addition, the 10, 25, and 50 ampere versions have different main contact springs and operating coils that the 100 and 150 ampere units. See Table I for identification information.

Each operating coil is designed for continuous duty at full voltage and does not require the insertion of a series resistor after pickup. The contactor will pick up and seal at 80% of rated voltage when the coil is hot, i.e., at operating temperature. The coil will also operate properly at 110% of rated voltage without burnout. Note that the normal operating temperature of an industrial contactor coil may exceed 100°C (212°F).

The Type ME₁₁ has one normally open (NO) and one normally closed (NC) main contact. The lower (normally closed) contact is held closed with spring pressure. One operating coil is used to close the upper (normally open) contact while opening the lower (normally closed) contact.

The ME contactor line is also intended as a replacement for earlier rear-connected contactors, Type M and MM. This requires the use of one rear-connection kit 2184A10G08 for each ME contactor. Instructions for the conversion are included in the kit.



INSTALLATION

Each ME contactor is intended to be mounted with its long axis vertical on a vertical flat metal panel. The two mounting holes have a 3/8 inch diameter. Use 5/16" diameter steel mounting bolts with a flat washer against the plastic base and a lockwasher under the head. When the contactor is mounted in position, there must not be any

TABLE I - DEVICE IDENTIFICATION
AND RATED CURRENTS

FRONT CONNECTED TYPE ME CONTACTORS				
Contactor Identification		Pole and Contact Arrangement	Open 8-Hour Current Rating DC Amperes	NEMA Frame Size
Catalog Number	Previous Catalog Number (less coil)			
ME010*	ME10-10	1NO	10	0
ME020*	ME20-10	2NO	10	0
ME011*	ME11-10	1NO, 1NC	10	0
ME001*	ME01-10	1NC	10	0
ME110*	ME10-25	1NO	25	1
ME120*	ME20-25	2NO	25	1
ME111*	ME11-25	1NO, 1NC	25	1
ME101*	ME01-25	1NC	25	1
ME210*	ME10-50	1NO	50	2
ME220*	ME20-50	2NO	50	2
ME211*	ME11-50	1NO, 1NC	50	2
ME201*	ME01-50	1NC	50	2
ME310*	ME10-100	1NO	100	3
ME320*	ME20-100	2NO	100	3
ME311*	ME11-100	1NO, 1NC	100	3
ME301*	ME01-100	1NC	100	3
ME410*	ME10-150	1NO	150	4
ME420*	ME20-150	2NO	150	4
ME411*	ME11-150	1NO, 1NC	150	4
ME401*	ME01-150	1NC	150	4

*Operating Coil Voltage Suffix - Standard coils are listed below:
 A = 65VDC B = 115VDC C = 125VDC
 D = 230VDC E = 250VDC F = 550VDC
 G = Other (customer specified)

grounded, any energized, or any combustible part inside of the minimum arcing clearance (dotted line shown on Figures 2, 3, 4, or 5) which is the exhaust pattern of the arc box.

The frame of the Type ME is at line potential when the contactor is energized. Gases and flashes of light from the arc box can also be hazardous. Make the installation accessible only to authorized and trained personnel.

Before mounting the contactor on the panel, make sure all circuits on the panel are de-energized. Check the nameplate and Table I to see that the current rating of the contact matches the application. Next, check the label on the operating coil to see that its rated voltage matches the coil supply voltage to the panel. Finally, ensure that the auxiliary contacts have the correct electrical function (normally open or normally closed) and the correct physical arrangement to agree with the wiring diagrams.

Instructions for Type ME Contactors and Type L46 or Type L66 Auxiliary Contacts Rated 600 Volts DC, Maximum

After the contactor is mounted to the panel, temporarily withdraw each arc box by disengaging the flat spring latch on the right side of the arc box and pulling the arc box forward, away from the panel, toward you. The arc box will be restrained by its polarizing shunt and need

not be completely removed, it can be temporarily supported by the polarizing shunt.

With the arc box clear, connect the line cable to the line terminal(s), using a lug for the cable and steel hardware in the clearance hole in the terminal. Refer to Figure 2, 3, 4, or 5 for the location of the .375" diameter terminal holes on the contactor.

Do NOT use hardware any longer than necessary. Make certain there is 1/2 inch clearance between the hardware and the mounting panel.

Next, connect the load cable to the load terminal at the bottom or center of the contactor, using similar hardware and maintaining at least 1/2 inch clearance.

With the panel still de-energized, operate the contactor by pushing on the top of the moving armature toward the panel with a screwdriver. The moving system should move freely on its bearing with no mechanical interference or rubbing.

REINSTALL THE ARC BOX BY SLIDING IT BETWEEN THE BLOWOUT IRONS UNTIL IT ENGAGES THE SPRING LATCH AND IS LOCKED.

Check the moving armature again by pushing with a screwdriver to make certain the mounting system can move freely, both in closing and opening movements.

Make the connections to the coil terminals and the auxiliary contact terminals.

The contactor is now ready for service. Precautions during the first power operation should be in accordance with safety practices appropriate to the application, and should be under the control of authorized and qualified personnel.

MAINTENANCE

This industrial type control is designed to be installed, operated, and maintained by adequately trained personnel. These instructions do not cover all details, variations, or combinations of the equipment, its storage, delivery, installation, checkout, safe operation, or maintenance. Care must be exercised to comply with local, state, and national regulations as well as safety practices for this class of equipment.

Make certain that the contactor and panel are completely de-energized before attempting any maintenance or repair.



WARNING

FAILURE TO COMPLETELY DISCONNECT THE CONTACTOR FROM ALL POWER SOURCES INCLUDING CONTROL CIRCUIT POWER PRIOR TO INSPECTION MAY RESULT IN SEVERE INJURY OR DEATH.

It is recommended that the contactor be examined at regular intervals so that preventive maintenance can be done. The frequency of examination will depend on how many interruptions per hour or per day the contactor must withstand. Ten to twenty operations per hour would suggest weekly examinations; ten to twenty operations per day would indicate examination every three or four months. In the beginning, examination should be relatively frequent until some history has been developed.

ARC BOX INSPECTION

Withdraw the arc box after unlatching and turn it over so that the inside can be observed. Some erosion, producing a whitish color is normal, as are some streaks of smoke. However, if the erosion produces cavities that might penetrate the arc box wall, or if the inside is glazed with metal globules or glass-like melted areas, the arc box should be replaced.

To completely remove the arc box, it is necessary to remove the screw securing the end of the polarizing shunt to the frame.



CAUTION

NEVER OPERATE CONTACTORS WITHOUT ARC BOXES LATCHED IN PLACE AND POLARIZING SHUNTS FASTENED TO THE MAIN FRAME.

POWER CIRCUIT CONTACTS

It is normal for contacts to show some burning and mechanical abrading. Every time a contactor operates, some material is lost from the contacts. When a contactor has operated so many times (and lost so much material) that the moving and stationary contact faces barely touch each other, then the contacts must be replaced.

The allowance for contact face wear is called "overtravel". When a Type ME contactor is new, the overtravel is at full value. When the overtravel has decreased to the minimum accepted shown in Figure 1, the contacts must be replaced.

Instructions for Type ME Contactors and Type L46 or Type L66 Auxiliary Contacts Rated 600 Volts DC, Maximum

INSTRUCTION LEAFLET IL17071
Effective April 2012

After a potentially difficult interruption, a contact may develop beads of metal. Such beads can be removed with a file and if the overtravel is still within limits the contactor can be returned to service. There is no need to try to file out every blackened pit in a contact.

However, if either contact face is so eroded that the silver alloy is gone and only copper remains, that contact must be replaced even if the overtravel is within limits.

Contact springs generally do not need attention unless they are damaged by a severe interruption or they wear out mechanically. Do not attempt to adjust a spring. Order replacement contacts and contact springs in kit form, one kit per pole. See Table III.

ARMATURE

The armature uses a knife edge bearing which should outlast the rest of the contact. It is intended to operate without lubrication so that it does not collect abrasive dust. The only maintenance required is to make certain that the moving armature does, in fact, move freely without interference or binding.

OPERATING COIL

If the operating coil is to be changed or replaced, first de-energize the panel and disconnect the coil terminals. Unlatch the arc box and withdraw. Next, loosen the two bolts holding the arc box and the moving system, which will then hang from the contactor suspended by the main current shunt. It is then apparent that the pole face screw and pole face can be removed to remove the coil. Keep track of the parts removed and replace them in the re-verse sequence with the replacement coil. Make certain when the equipment is complete that the moving system moves freely and the arc box is properly installed.

REPLACEMENT DEVICES

Order replacement devices and coils by type designation shown on the nameplate, which is coded as shown in Table I. The contactor type number does not include auxiliary contacts (electrical interlocks). These must be specified separately by contact arrangement.

AUXILIARY CONTACTS

Each ME contactor can accommodate two Type L46 auxiliary contacts. Type ME_11 double-throw contactors (1NO/1NC) can mount two L46's per throw. A Type L66 normally closed delayedbreak auxiliary contact may be substituted for the Type L46, except on Type ME_01 and in the upper position on the Type ME_11 contactors. In addition, the Type ME_10 contactors (1NO) can accommodate two extra, outboard mounted, auxiliary contacts.

When ordering auxiliary contacts, specify Type L46, the mode (normally open or normally closed) or Type L66 normally closed delayedbreak, and the type designation of the ME contactor on which the auxiliary contact is to be mounted. See Table II for auxiliary contact ratings.

AUXILIARY CONTACT CONSTRUCTION

The stationary contact assembly consists of a pair of silver contact buttons welded to supports which are secured to an insulating base.

The moving contact, comprising a pair of silver buttons welded to a crossmember, is carried on an insulating arm which is attached to the magnet armature. It is provided with a contact spring which insures that adequate pressure is maintained as the contacts wear.

Note that auxiliary contacts performing as normally closed contacts when mounted on single pole normally open and two pole contactors function instead as normally open contacts when mounted on single pole normally closed contactors or on the lower side of multiple contactors.

AUXILIARY CONTACT INSTALLATION

AND MAINTENANCE

The stationary part of the auxiliary contact is secured by a screw to the insulating base of the contact, occupying a position between the arc shields if the base carries two main poles, and a position beside the arc shield if the base carries a single main pole.

The contact alignment when the contacts are new should be such that the two pairs of contacts meet simultaneously as the auxiliary contact closes, and that the moving contact collar then advances an additional 3/32 inch before coming to rest. The overtravel is adjusted by bending the stationary contacts. The final force exerted against the stationary contacts by each of the moving contact buttons should be 3 ounces.

The contacts should be replaced when they have worn to the extent that the overtravel has been reduced from the initial 3/32 inch to less than 1/32 inch.

Make periodic inspections to see that the auxiliary contact parts move freely without friction or binding. Oil should not be used on any part of the device, as it hastens the accumulation of dust.

Instructions for Type ME Contactors and Type L46 or Type L66 Auxiliary Contacts Rated 600 Volts DC, Maximum

TABLE II - AUXILIARY CONTACT INFORMATION					
All auxiliary contacts are front-connected only					
Inboard Mount Auxiliary Contacts - 1 auxiliary contact per side, either Type L46 or Type L66 (1 auxiliary contact per side for each power contact on ME011, ME111, ME211, ME311, or ME411)					
PLUS					
Outboard Mount Auxiliary Contacts - 1 auxiliary contact per side, either NC Type L46 or Type L66 (available for ME010, ME110, ME210, ME10, and ME410 only)					
Auxiliary Contact Ratings		Normally Open Type L46	Normally Closed Type L46	Delayed Break Normally Closed	
				Left Side Mount Type L66	Right Side Mount Type L66
At 10-200VDC	Make Break	10 Amps		10 Amps	
At 20-600VDC	Make Break	200VA		200VA	
ME Contactor Catalog No.		Auxiliary Contact Catalog Number			
ME010, ME110, ME210, ME310, ME410 (1 pole NO contactor)	Inboard Mount	11A8713G09	11A8713G10	659C301G04	659C301G05
	Outboard Mount	N/A	487B878G01	487B878G06	487B878G07
ME001, ME101, ME201, ME301, ME401 (1 pole NC contactor)	Inboard Mount	11A8713G10	11A8713G09	N/A	N/A
ME011, ME111, ME211, ME311, ME411 (1 pole NC/NO contactor)	Inboard Mount	11A8713G09	11A8713G10	659C301G04 (For use only on lower armature)	659C301G05
ME020, ME120, ME220, ME320, ME420 (2 pole NO contactor)	Inboard Mount	11A8713G09	11A8713G10	659C301G04	659C301G05

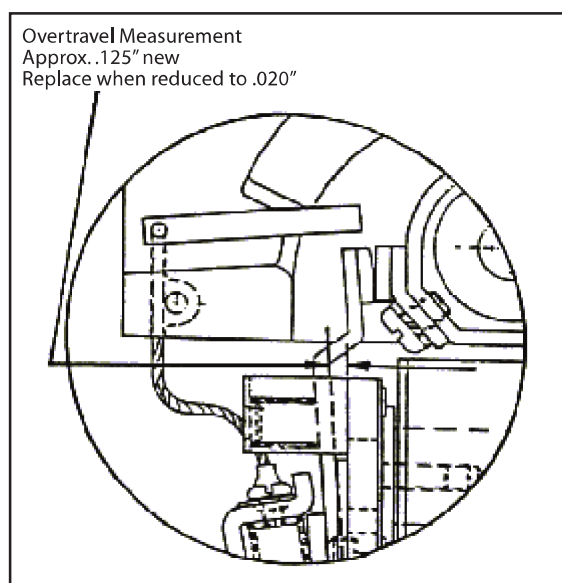

Fig. 1 Measuring Contact Overtravel

TABLE III CONTACTOR RENEWAL PARTS		
Pole Arrangement	Part Description	Part Number
All	Contact and Contact Spring Kit (1 pole)	2184A10G14
2NO	Contact Support Kit	2184A20G17
2NO	Shunt Replacement Kit	2184A20G16
1NO / 1NC	Shunt Replacement Kit	2187A11G07
1NO	Shunt Replacement Kit	2184A10G21
1NC	Shunt Replacement Kit	2184A10G21
2NO	Armature Kit	2184A20G15
1NO / 1NC	Armature Kit	2184A11G06
1NO	Armature Kit	2184A10G19
1NC	Armature Kit	2184A10G19
All	Coil Mounting Kit	2184A10G20

Instructions for Type ME Contactors and Type L46
or Type L66 Auxiliary Contacts Rated 600 Volts DC,
Maximum

INSTRUCTION LEAFLET IL17071
Effective April 2012

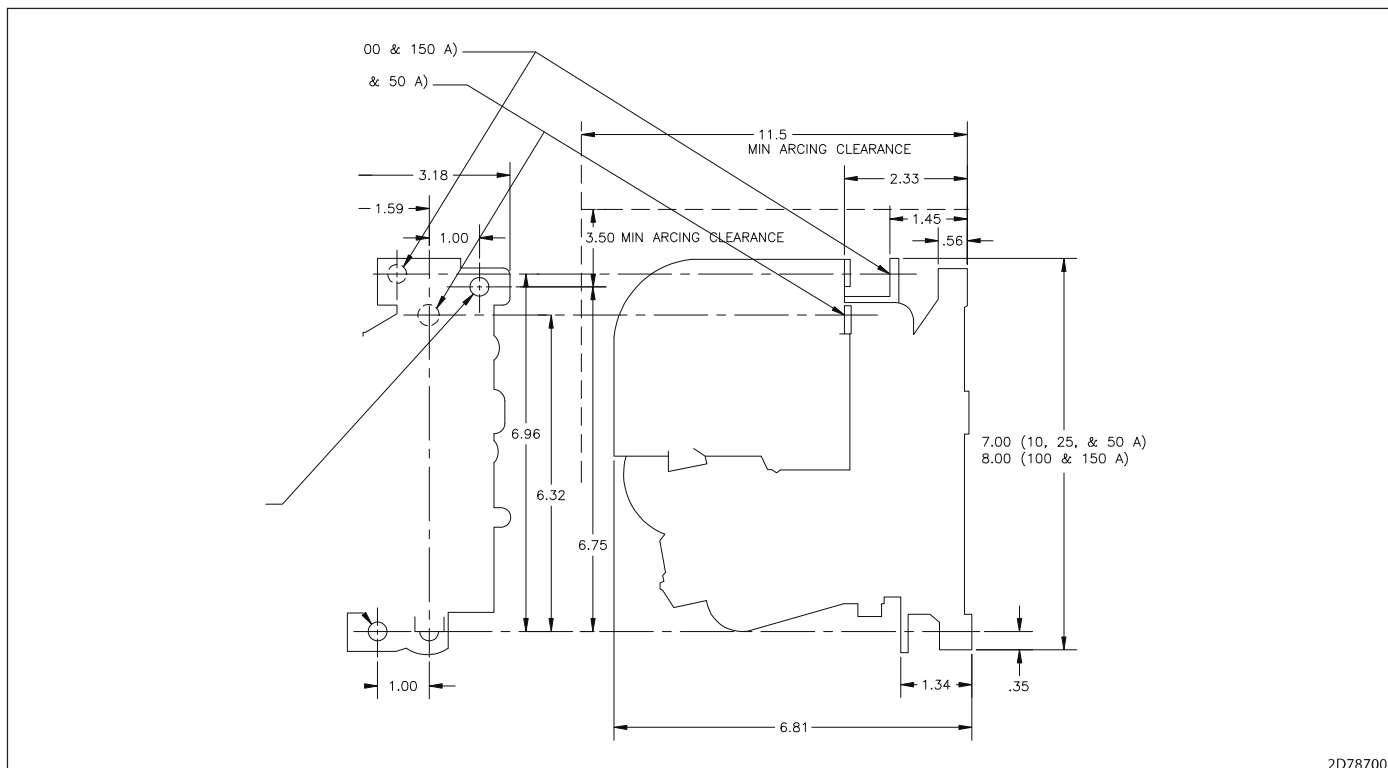

Fig. 2 Dimension Drawing of NO Pole ME Contactor (dimensions in inches)

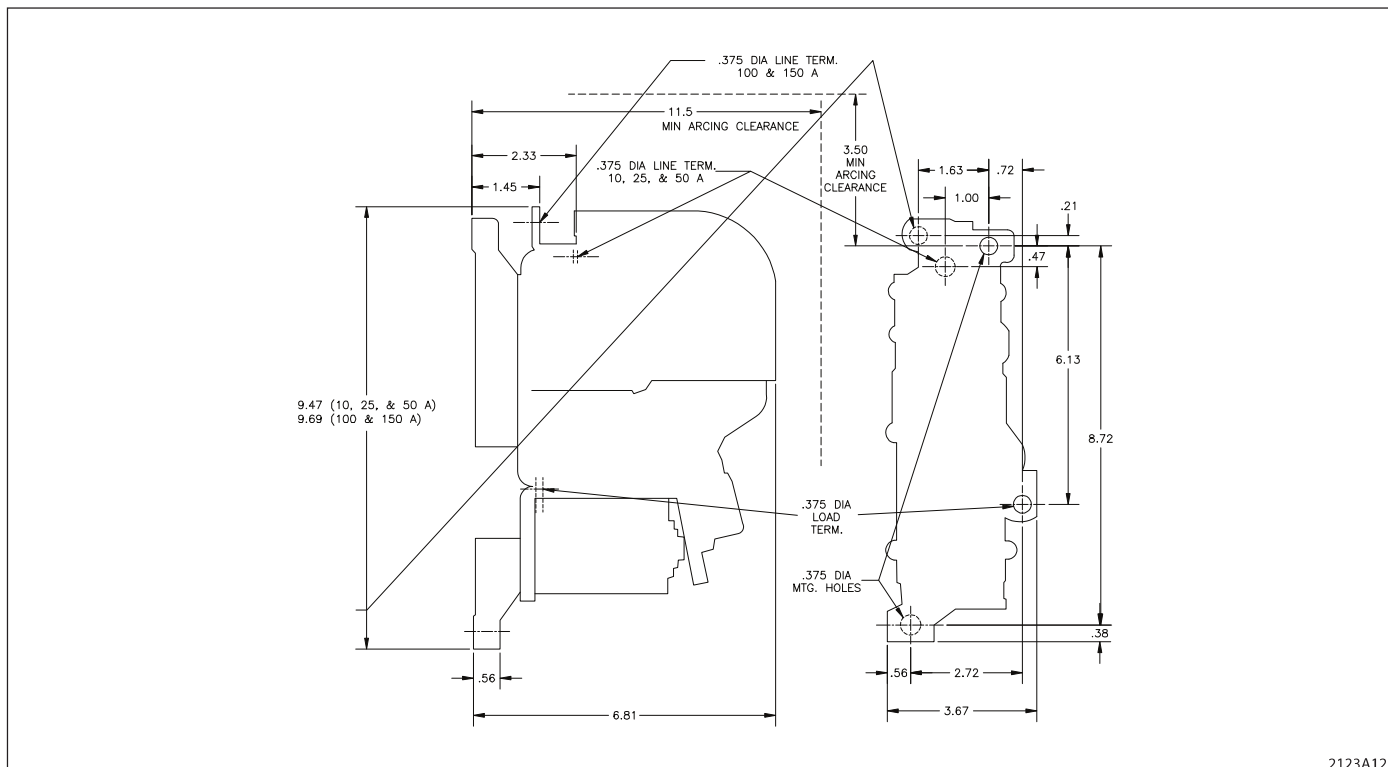

Fig. 3 Dimension Drawing of 1NC Pole ME Contactor (dimensions in inches)

Instructions for Type ME Contactors and Type L46 or Type L66 Auxiliary Contacts Rated 600 Volts DC, Maximum

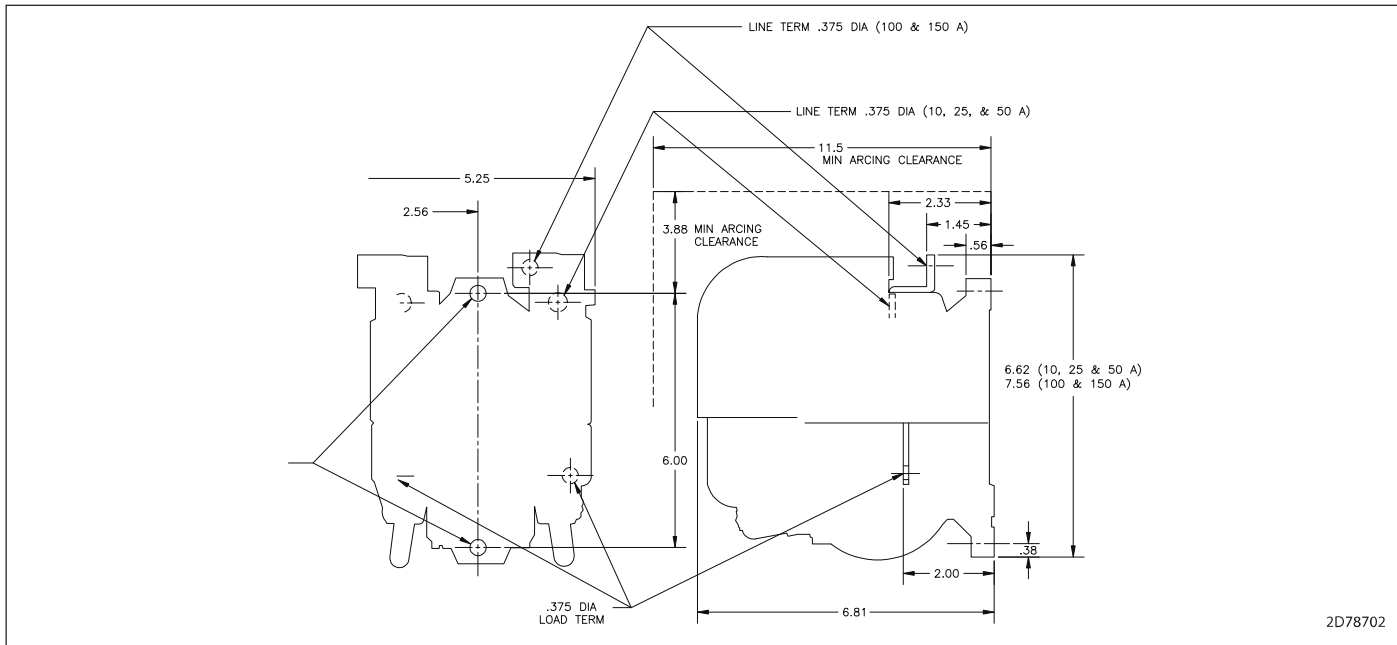

Fig. 4 Dimension Drawing of 2NO Pole ME Contactor (dimensions in inches)

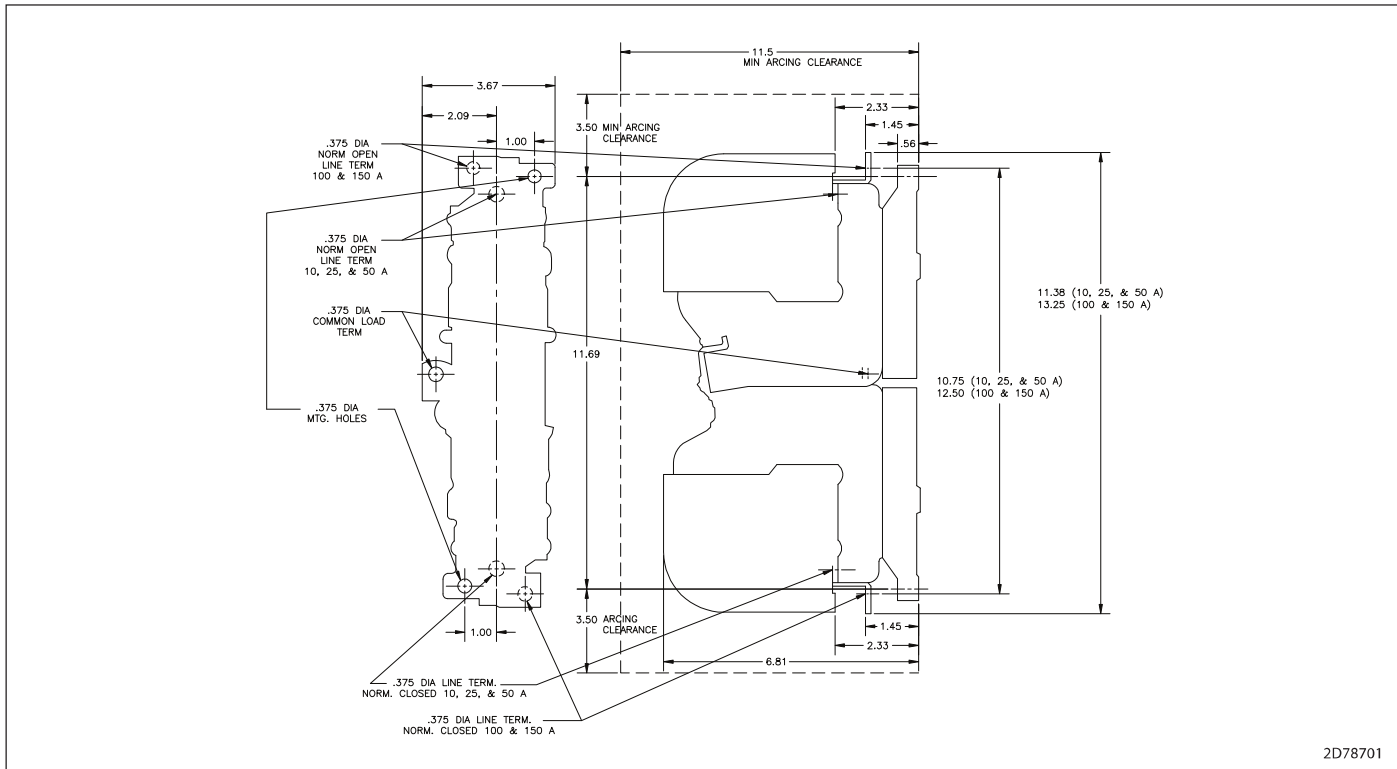

Fig. 5 Dimension Drawing of 1NO and 1NC Pole ME Contactor (dimensions in inches)

Eaton Corporation
 Electrical Sector
 1111 Superior Ave.
 Cleveland, OH 44114
 United States
 877-ETN-CARE (877-386-2273)
 Eaton.com

© 2012 Eaton Corporation
 All Rights Reserved
 Publication No. IL17070 / 002
 April 2012

Eaton is a registered trademark of Eaton Corporation.

All other trademarks are property of their respective owners.

