

RENEWAL PARTS PUB NEMA SIZE 6 NON-REVERSING AND REVERSING CONTACTORS AND STARTERS

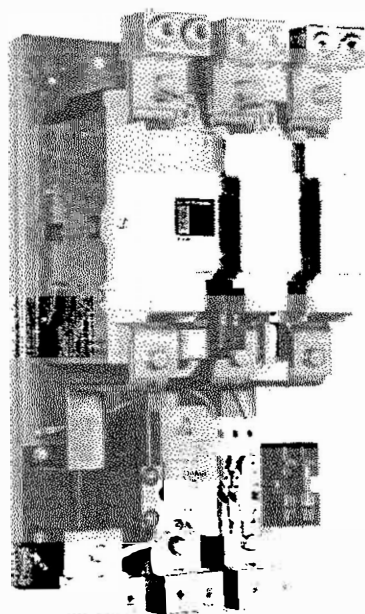

NEMA Size 6 Starter

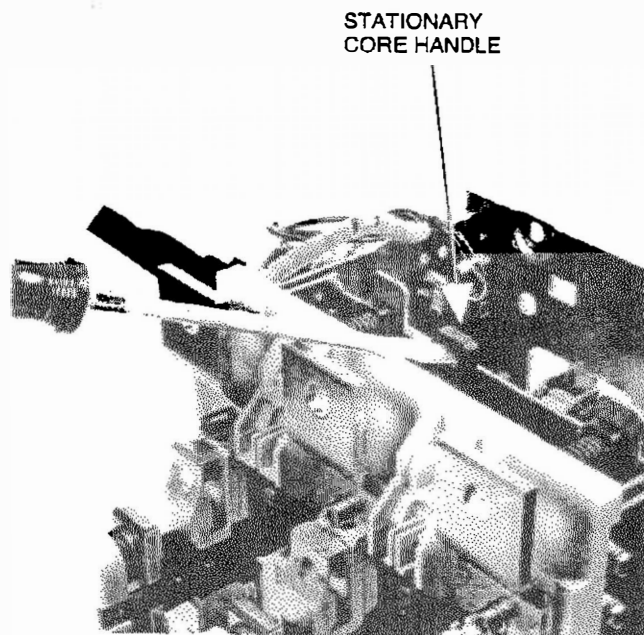

Figure 1 - Coil Removal

INTRODUCTION

This publication is designed to simplify inspection and maintenance through the use of photographs and detail views for easy identification of parts. Illustrated steps on assembly and disassembly are shown. This information should be read carefully.

DESCRIPTION

This publication covers 3 pole, 3 phase non-reversing and reversing contactors and starters with ratings as shown on the nameplates.

CARE

These contactors/starters require no mechanical maintenance. If maintenance is needed, please note that these devices use metric hardware. All power contacts should be renewed at the same time before the contact tip material has worn away. Refer to Publication 14183 for helpful information on inspecting and determining when to replace the contacts. When renewing contacts, check all terminal screws to insure they are tight and secure.

During routine electrical maintenance, the arc chutes are to be removed to inspect the main contacts for wear. Please note Figure 4 exploded view drawing for service or repair.

	DANGER
	Hazard of Burn or Electrical Shock!
	Turn OFF power supplying this equipment before working inside.

All work on this contactor should be done with the main circuit disconnect device open. There is danger of electrocution and/or severe burns. Make certain that power is off. Also, disconnect power from any other external circuits.

ARC CHUTE REMOVAL

1. Disconnect all power to the contactor/starter.
2. Loosen the 2 screws attached to the arc chute.
3. Remove the arc chute.
4. To reinstall arc chute, reverse the above.

MAIN COIL RENEWAL

Caution - If the device has been in service, many parts may still be thermally hot.

1. Disconnect all power to the contactor/starter.
2. Remove arc chute.
3. Remove feeder group (see Feeder Group Removal on Page 2, Figure 2). DO NOT DISCONNECT WIRES. Insert the tip of a long shaft screwdriver into the eye of the stationary core handle as shown in Figure 1. Using the screwdriver as a lever, gently pry stationary core upward until detents on the sliding blocks engage stop bars of contactor frame.
4. Loosen the screws that secure each coil.
5. Grasp the coil by its handle. Lift slightly up and pull forward to remove.
6. Slide in new coils and tighten the coil screws to secure in place.
7. Push stationary core down into coils until core bottoms out.
8. Reinstall feeder group and arc chute.

Main Coils

Control Voltage		Main Coil Part No. (1 Required per Contactor)
Volts	Hertz	
110-120	50/60	9-3006
220-240	50/60	9-3006-2
440-480	50/60	9-3006-3
550-600	50/60	9-3006-4
200-218	50/60	9-3006-5
380-415	50/60	9-3006-7
255-277	50/60	9-3006-6

NOTE: Voltage ratings of the main coils must match those of the feeder group for proper operation of the starter/contacter.

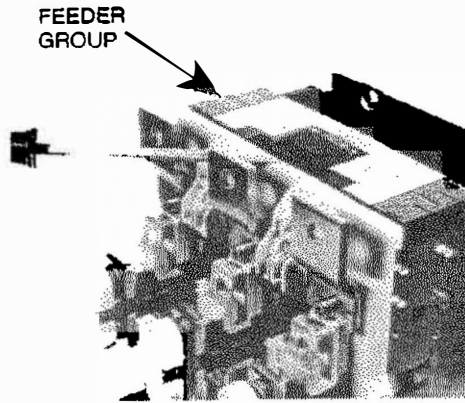

Figure 2 - Feeder Group

FEEDER GROUP

It supplies the main contactor coils with DC control voltage. Refer to the wiring diagram publication supplied with the contactor/starter when reconnecting wires to the new feeder group.

FEEDER GROUP RENEWAL

1. Disconnect all power to the contactor/starter.
2. Insert a screwdriver as shown in Figure 2 to pry the feeder group from the contactor frame.
3. Disconnect the 6 wires going to the feeder group.
4. Connect the 6 wires to the new feeder group. Refer to the diagram supplied with the contactor/starter.
5. Assemble new feeder group by inserting the 2 feeder group mounting tabs into the two slots in the contactor frame and press into the contactor frame.

Feeder Group Renewal

Control Voltage		Feeder Group (Complete)
Volts	Hertz	
110-120	50/60	9-3007
220-240	50/60	9-3007-2
440-480	50/60	9-3007-3
550-600	50/60	9-3007-4
208	50/60	9-3007-5
380-415	50/60	9-3007-7
48-52	50/60	9-3007-6

NOTE: Voltage ratings of the main coils must match those of the feeder group for proper operation of the starter/contactor.

MAIN CONTACT RENEWAL

Caution - If the device has been in service, many parts may still be thermally hot.

1. Disconnect all power to the contactor/starter.
2. Remove arc chute.
3. Press down on the movable contact assembly until the locking pins become loose. Remove locking pins by sliding them to the right or left. See Figure 3.
4. Release pressure on the movable contact assembly and remove.
5. Remove stationary contacts by removing the allen screws. Use a 6mm allen wrench.
6. Install new stationary contacts and screws.
7. Assemble contact, springs, and spring retainers. Press down on the movable contact assembly and install the locking pins.
8. Install arc chute.

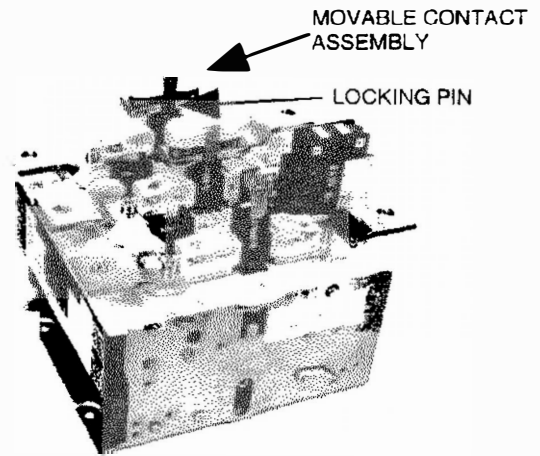

Figure 3 - Main Contact Renewal

RENEWAL OF CURRENT TRANSFORMER

1. Disconnect all power to the starter.
2. Remove the 2 screws holding the fuse block to the mounting plate and set fuse block aside.
3. Remove green and black wires from the line side of the overload relay.
4. Remove current transformer secondary wires from overload relay.
5. Remove 4 screws holding overload relay and mounting plate to current transformer and set aside.
6. Remove load side power lugs.
7. Remove current transformer mounting screws.
8. Remove current transformer by sliding down to clear base.
9. Reinstall new current transformer by reversing the above. Make sure the transformer polarity is correct. Refer to wiring diagram supplied with starter.

RENEWAL OF BIMETAL OVERLOAD RELAY

This bimetal, ambient compensated overload relay is adjustable within the FLA range of the heater pack. Each heater pack is marked with its range of FLA ratings.

Select heater packs (**3 required**) according to the motor FLA rating and install in overload relay. Rotate FLA adjustment dial to a position corresponding to the motor FLA. Consult overload relay publication supplied with the starter for proper setting and selection. The overload relay is factory set for manual reset operation. If automatic reset is required, turn the reset adjustment dial to "A".

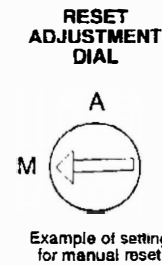
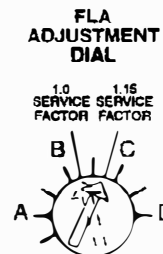

The entire overload relay must be replaced if burnout of the heater occurs.

DO NOT disassemble this relay!

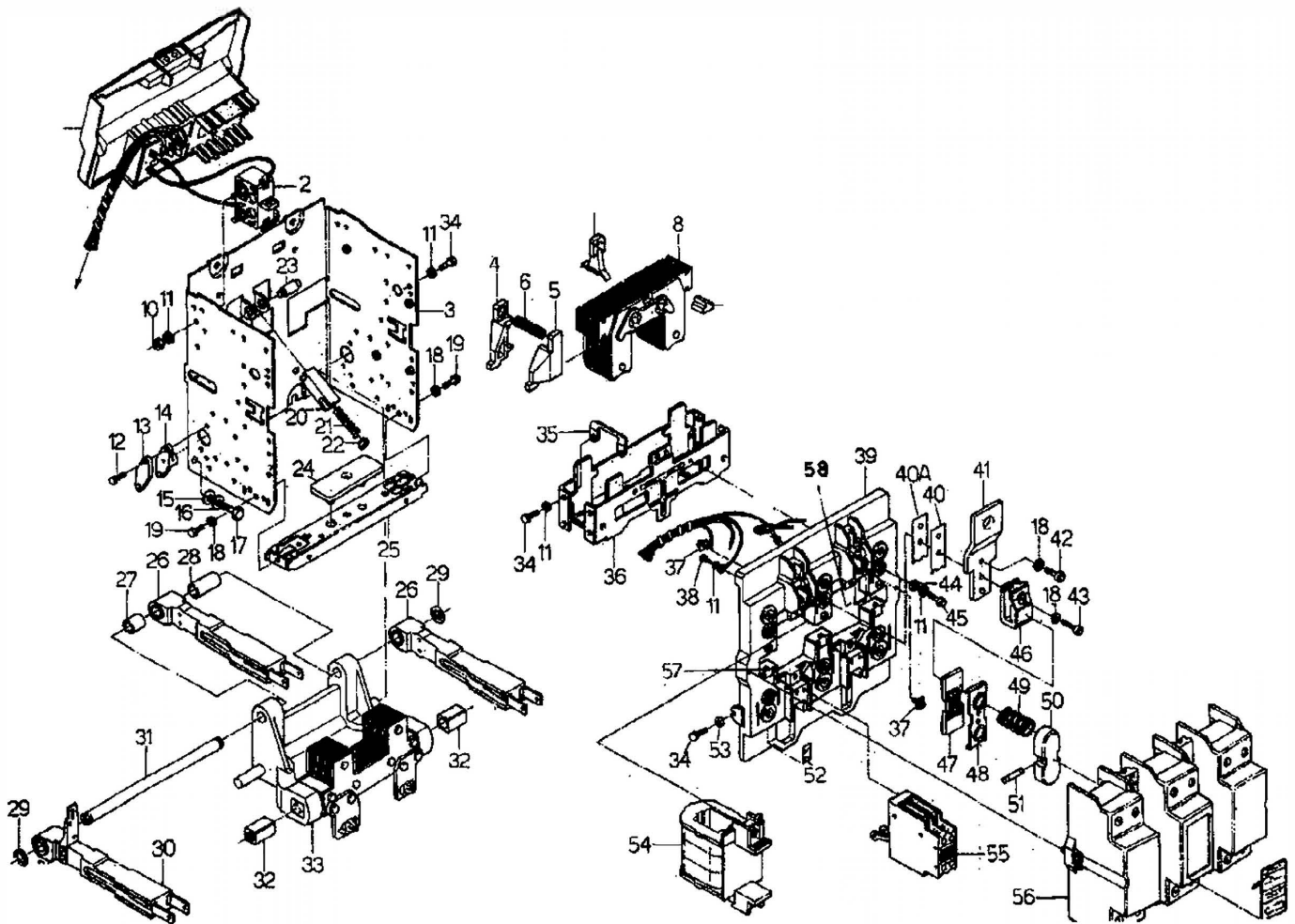

Figure 4

(Figures 4, 5, 6, and 7)

NOTE: Only the parts listed with a part number are available for replacement. All other parts are shown and described for identification only

ITEM NUMBER	DESCRIPTION	PART NUMBER	QUANTITIES			
			CN15 Non-Rev Contr	AN16 Non-Rev Str	CN55 Rev Contr	AN56 Rev Str
1	Feeder Group (complete)	See Table Page 2 for Voltage Selection 10-6144	1	1	2	2
2	Saving Resistor - AC Interlock		1	1	2	2
3	Contacteur Frame		1	1	2	2
4	Right Sliding Block	See Item 79	2	2	4	4
5	Left Sliding Block	See Item 79	2	2	4	4
6	Sliding Block Spring	See Item 79	2	2	4	4
7	Stationary Core Handle	See Item 80	1	1	2	2
8	Stationary Core	17-21319	1	1	2	2
9	Core Stop	See Item 60	2	2	4	4
10	M5 x 3.5 Hex Nut		2	2	4	4
11	M5 x 3.5 Washer		14	14	28	28
12	M5 x 3.5 Screw		4	4	8	8
13	Drive Lever Flange		2	2	4	4

ITEM NUMBER	DESCRIPTION	PART NUMBER	QUANTITIES			
			CN15 Non-Rev Contr	AN16 Non-Rev Str	CN55 Rev Contr	AN56 Rev Str
14	Drive Lever Bushing		2	2	4	4
15	M8.5 Flat Washer		1	1	2	2
16	M8.5 Helical Lockwasher		1	1	2	2
17	M8 x 10 Screw		1	1	2	2
18	M6.4 Helical Lockwasher	See Item 78	1	1	2	2
19	M6 x 10 Screw		14	14	28	28
20	Return Spring Guide		2	2	4	4
21	Return Spring		1	1	2	2
22	Return Spring Slide		1	1	2	2
23	Return Spring Contrast Pivot		1	1	2	2
24	Moving Core Shock Absorber		1	1	2	2
25	Moving Core Crossbar		1	1	2	2
26	Moving Contact Drive	17-21321	2	2	4	4
27	Short Spacer		1	1	2	2
28	Long Spacer		1	1	2	2
29	Clip Ring		2	2	4	4
30	Moving Contact Drive	17-21322	1	1	2	2
31	Moving Contact Drive Pivot		1	1	2	2
32	Core Bushing		2	2	4	4
33	Drive Lever Group	See Item 60	1	1	2	2
34	M5 x 10 Screw		10	10	20	20
35	Stationary Core Stop Plate		2	2	4	4
36	Stationary Core Support		1	1	2	2
37	M3.5 Screw w/Plate		8	8	16	16
38	M5 x 7 Screw		2	2	4	4
39	Contact Support		1	1	2	2
40	0.5mm Shim Plate		6	6	12	12
40A	1.0mm Shim Plate		6	6	12	12
41	Terminal Plate		6	6	12	12
42	M6 x 14 Screw		6	6	12	12
43	M6 x 20 Screw	See Item 78	6	6	12	12
44	M5.3 Flat Washer		2	2	4	4
45	M5 x 12 Screw		2	2	4	4
46	Stationary Contact	See Item 78	6	6	12	12
47	Movable Contact	See Item 78	3	3	6	6
48	Arc Runner	See Item 78	3	3	6	6
49	Contact Spring	See Item 78	6	6	12	12
50	Spring Retainer	See Item 78	3	3	6	6
51	Spring Locking Pin	See Item 78	3	3	6	6
52	Label (not supplied)		--	--	--	--
53	Spring Washer		2	2	4	4
54	Main Coil Set **	See Table, Page 1	1	1	2	2
55	Auxiliary Contact (2NO-2NC)	C320KA8	1	1	2	2
56	Arc Chute Assembly	62-1095-3	1	1	2	2
57	Slide		3	3	6	6
58	Connector		1	1	2	2
59	Fuseholder	C350FDR	--	1	1	1
60	Lug	80-8020	6	6	6	6
61	3/8-16 x 1.250" Hex Head Screw	911-5650Z	6	6	6	12
62	3/8" Helical Lockwasher	916-231	6	6	6	6
63	3/8" Flat Washer	916-882Z	6	6	12	15
64	3/8" Hex Nut	915-1004Z	6	6	12	15
65	3/8-16 x 1.500" Hex Head Screw	911-5652Z	--	--	6	3
66	Bus Bar	25-11220	--	--	--	3
67	Bus Bar	25-11221	--	--	1	1
68	Bus Bar	25-11222	--	--	2	2
69	Bus Bar	25-11223	--	--	1	1
70	Bus Bar	25-11224	--	--	1	1
71	Bus Bar	25-11225	--	--	1	1
72	Current Transformer	42-3973	--	--	--	--
73	Overload Relay	C306DN3	--	--	--	--
74	Mounting Plate	17-20898	--	--	--	1
75	10-32 x .500" Truss Head Screw	11-942	--	4	--	4
76	Terminal Block	10-6380-2	--	--	--	1
77	8-32 x .687" Sems Screw	11-5288-2	--	--	--	2
78	Contact Kit (not shown) (incl items 18, 43, & 46 thru 51)	6-648	1	1	2	2
79	Magnet Repair Kit (includes Items 4, 5, 6, & 9)	99-3467-2	1	1	2	2
80	Stationary Core Handle Repair Kit	99-3468-2				
81	Mechanical Interlock	C321KM70	1	1	2	2

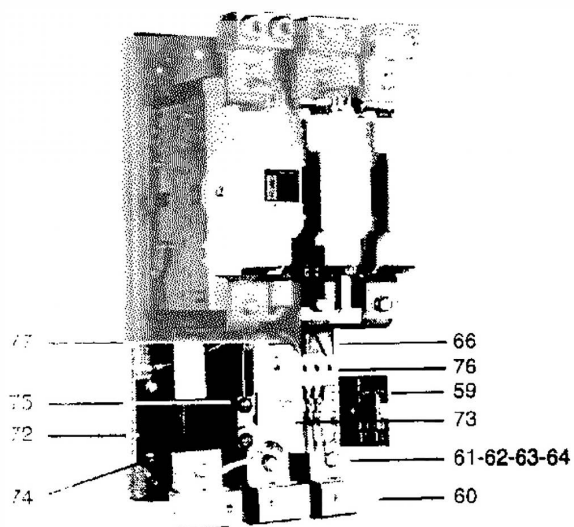

Figure 5

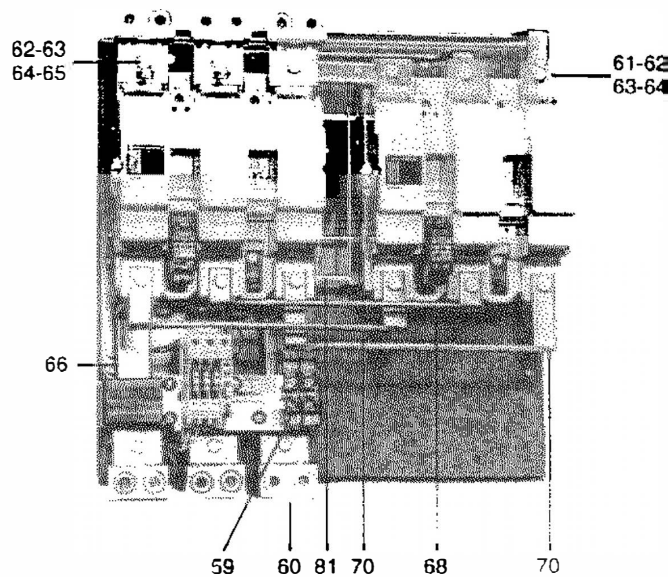

Figure 7

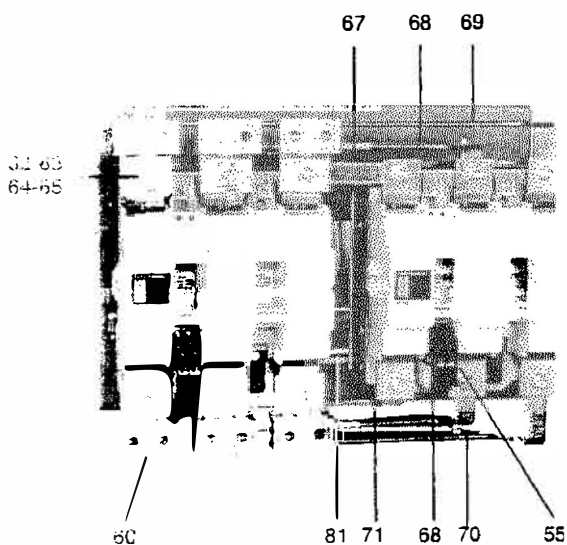

Figure 6

AUXILIARY INTERLOCKS (Figure 8)

The electrical interlocks are renewable as a complete assembly and are available in a 2NO-2NC configuration.

Little is required for the interlocks beyond occasional examination to ensure that parts move freely without interference or binding.

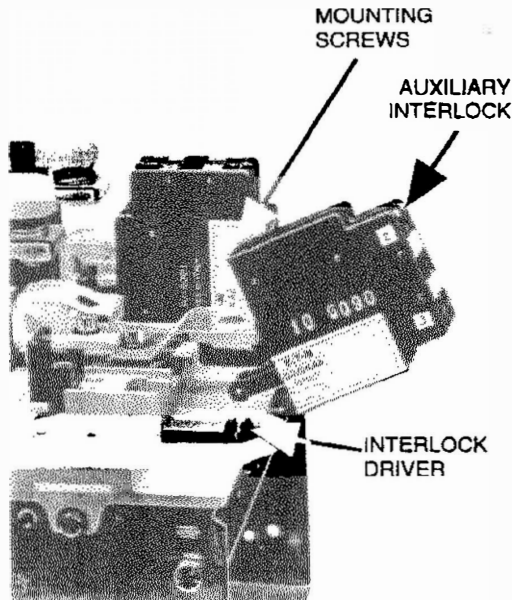

Figure 8

INSTALLATION INSTRUCTIONS

1. **Disconnect all power** to contactor/starter.
2. Insert operating lever of auxiliary interlock into left- or right-hand interlock driver of contactor.
3. Align mounting screws of auxiliary contact with integral inserts on contactor frame and tighten screws to secure auxiliary interlock to contactor.

MAINTENANCE AND RENEWAL OF MAGNET CORE STOPS

The contactor should be periodically inspected for wear or erosion of the magnet core stops. See Figure 4, Item 9. If this inspection reveals the core stops should be replaced, order the magnet repair kit listed in Figure 4, Item 79.

1. **Disconnect all power** to the contactor/starter.
2. Remove feeder group. See Figure 2. **Do not** disconnect wires connected to the feeder group.
3. Energize power to the contactor coil.
4. Observe the saving resistor interlock, Figure 6, Item 2 and compare to Sketches "A" and "B".
5. If the white indicator appears as shown in Sketch "A", the core stops are still serviceable. If the white indicator appears as shown in Sketch "B", the core stops should be replaced.

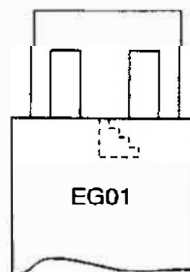

Sketch "A"

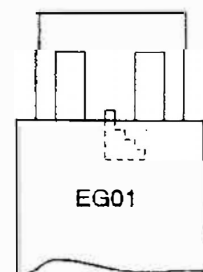

Sketch "B"