

RENEWAL PARTS PUB NEMA SIZE 5 NON-REVERSING & REVERSING STARTERS

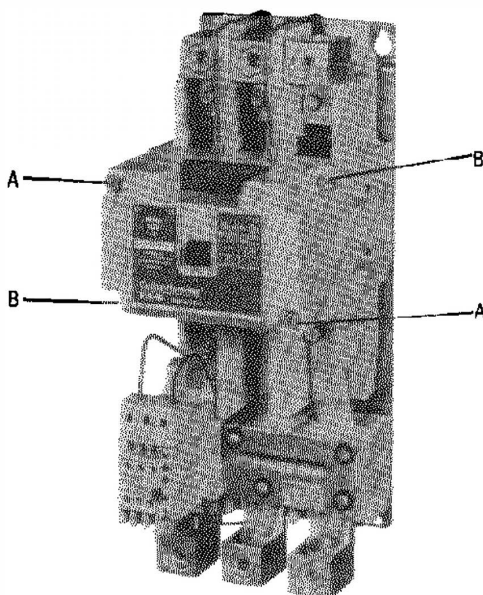

TYPICAL SIZE 5 STARTER (FIGURE 1)

INTRODUCTION

This publication is designed to simplify inspection and maintenance through the use of photographs and detail views for easy identification of parts. Illustrated steps on assembly and disassembly are shown. This information should be read carefully.

DESCRIPTION

This publication covers 2 pole and 3 pole, 3 phase non-reversing and reversing, starters with ratings as shown on the nameplates.

CARE

These starters require no mechanical maintenance. All power contacts should be renewed at the same time before the contact tip material has worn away. Refer to publication 14183 for helpful information on inspecting and determining when to replace the contacts. When renewing contacts check all terminal screws to insure they are tight and secure.

NOTE — Disconnect power before any functions are performed on the starter.

RENEWAL OF OPERATING COIL (Figure 1)

The operating coil is epoxy encapsulated and so constructed to provide long service life. Should the coil require changing, the entire operation can be performed in a few minutes.

1. Disconnect all power to the starter.

Unfasten the two pan head cover screws "A" and remove the cover item 18 page 3.

Unfasten the four pan head screws securing the clamp item 17 and the armature item 23. Remove the clamp and the armature.

Pull the coil straight out.

Install the new coil with the coil terminal blades engaging the coil terminal clips.

Install the armature (narrow end to the left) into its seated operating position.

Install the clamp and secure the screws.

Install the cover.

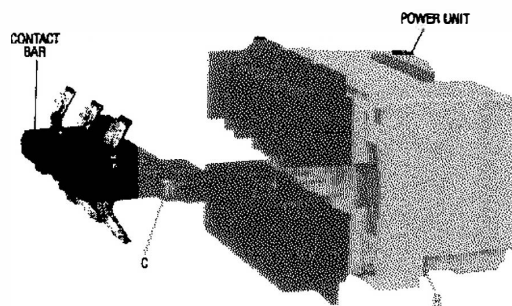

RENEWAL OF POWER CONTACTS (Figure 2)

The power contacts when used within their rating will provide long trouble free life. They should not be filed or dressed.

Caution — If the device has been in service, many parts may still be thermally hot.

DISCONNECT POWER

1. Remove the power unit assembly by loosening the two gold colored slotted hex. head screws "B" and pull out the power unit. (**NOTE** — when removing or installing, tilt the Power Unit to clear the coil terminals.)

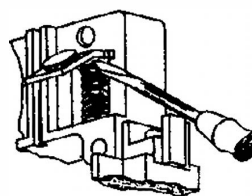

SKETCH "A"

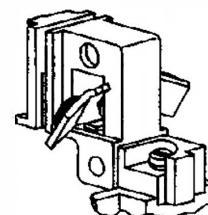

SKETCH "B"

MOVABLE CONTACTS

2. Remove the contact bar by removing screw "C".
3. Refer to sketch "A". Insert a small screwdriver into the window of contact bar. Depress contact spring and remove.
4. Refer to sketch "B". Rotate contact and remove.
5. Insert the new contact so that the embossment of contact faces the integral nib of the contact bar.

(Continued on page 2)

(Continued from page 1)

6. Compress the spring with fingers and insert into window. The spring must engage both the integral nib of the contact bar and embossment of contact in order to seat properly.

7. Install Contact Bar to Power Unit with screws "C".

Note: The contact bar is not reversible. Match the ends of the contact bar to fit inside the raised projections on the push-bars.

STATIONARY CONTACTS

Note: It is not necessary to disconnect any wiring.

8. Remove the screws securing the stationary contacts.

9. Install the new contact and screws.

RENEWAL OF BIMETAL OVERLOAD RELAY

The bimetal, ambient compensated Overload Relay is adjustable within the FLA range of the heater pack. Each heater pack is marked with its FLA ratings. These ratings are multiplied by the transformation ratio (60) of the current transformer, and shown in the heater pack selection table.

Select heater packs according to motor FLA rating and install in overload relay. Rotate FLA adjustment dial to a position corresponding to the motor FLA. Consult overload relay publication supplied with the starter for proper setting and selection. The overload relay is factory set for manual reset operation. If automatic reset is required, turn the reset adjustment dial to "Auto".

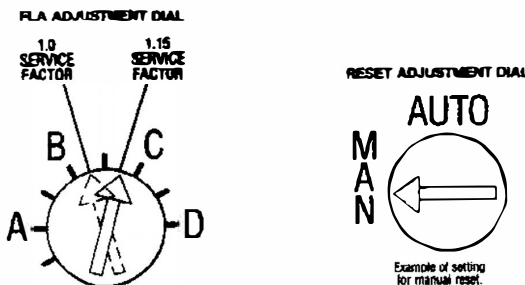

The entire overload relay must be replaced if burnout of the heater pack occurs.

DO NOT disassemble this relay!

RENEWAL OF CURRENT TRANSFORMER (Figure 3)

1. Disconnect all power to the starter.
2. Disconnect all wires to the overload relay.
3. Loosen the six mounting screws and remove the overload relay mounting plate from the current transformer.
4. Loosen mounting screws and remove load side lugs from starter.
5. Loosen and remove the two current transformer mounting bolts from the back side of starter mounting plate.
6. Loosen bus bar screws and slide current transformer off of starter.

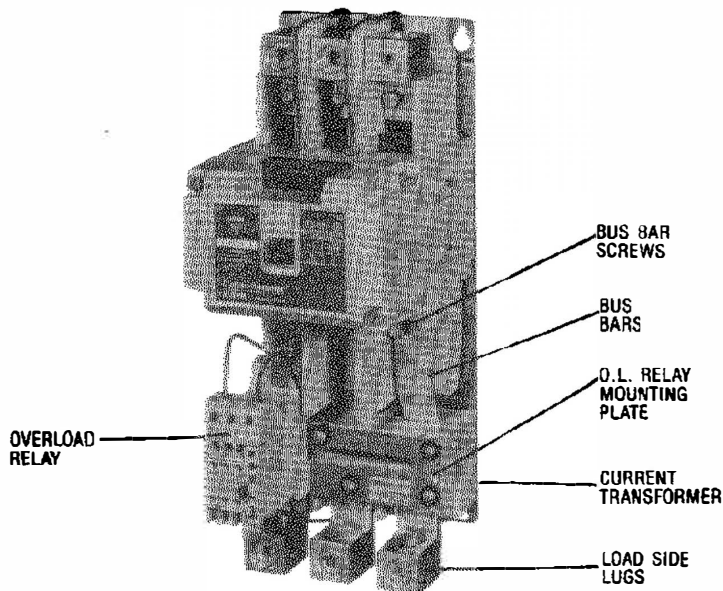

FIGURE 3

7. Slide new current transformer onto bus bars and tighten bus bar screws to 65 lb.-in. of torque.
8. Reinstall the two current transformer mounting bolts at the back side of starter mounting plate.
9. Reinstall load side lugs and torque lug mounting screws to 65 lb.-in.
10. Reinstall O.L. Relay and mounting plate onto current transformer.
11. Reconnect wiring to overload relay according to wiring diagram.

LUBRICATION

Do not lubricate any part of this equipment.

AUXILIARY CONTACTS

The auxiliary contacts are renewable as a complete assembly. See table on page 4 the various auxiliary contacts.

ARC CHUTES

These seldom require renewal. Some burning and discoloration are normal. When the contacts are renewed, brush out any loose accumulations.

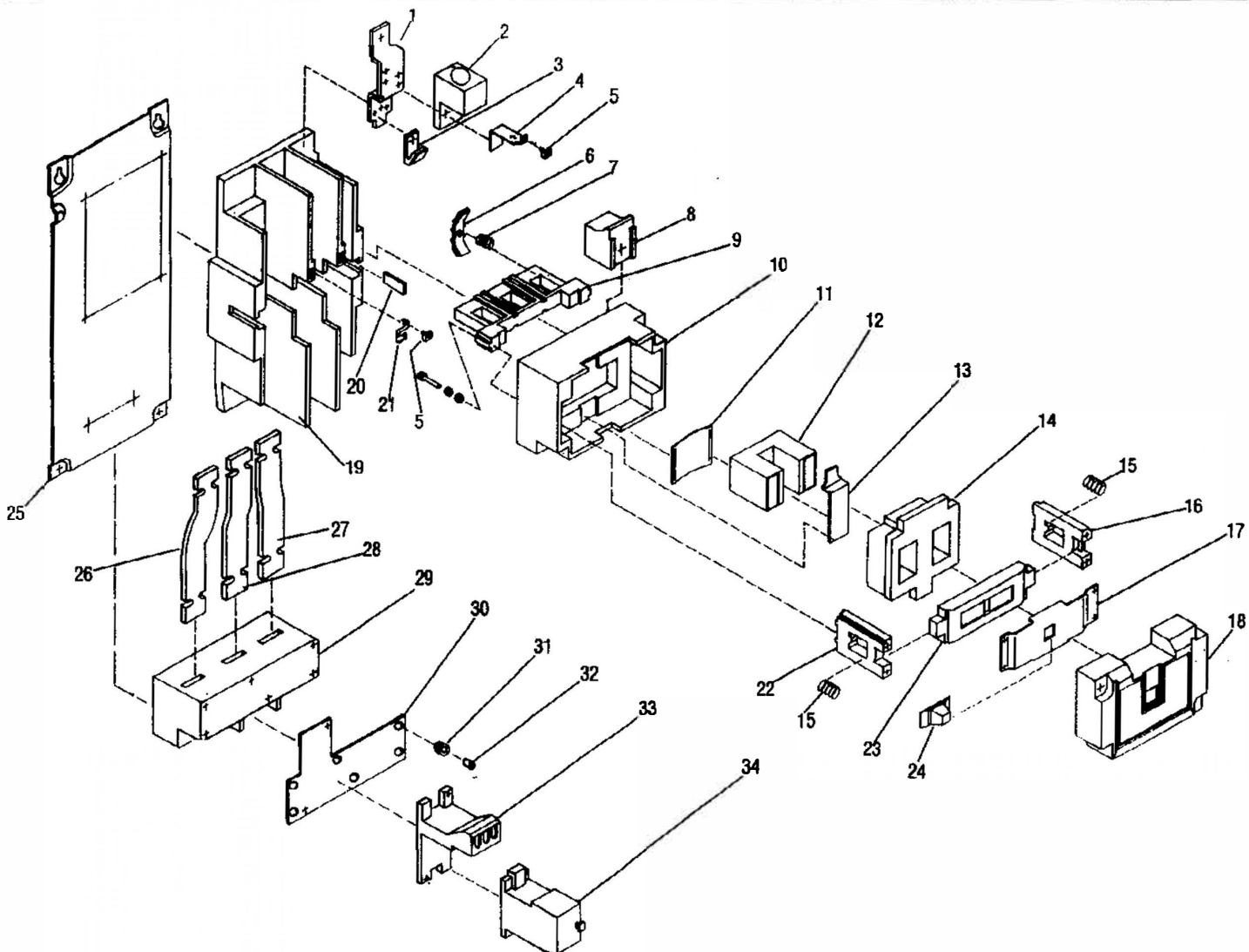

RENEWAL PARTS — Information Required

To insure prompt handling of renewal parts orders, please include the following: **DESCRIPTION, PART NO., AND QUANTITY REQUIRED.**

PARTS LIST

| Item No. | Description | Part No. | Quantities | | Item No. | Description | Part No. | Quantities | |
|----------|-----------------------------|-----------------------|------------|------|----------|---|------------|------------|------|
| | | | AN16 | AN56 | | | | AN16 | AN56 |
| 1. | Terminal Plate | 80-6362 | 6 | 12 | 17. | Bracket | 79-17426 | 1 | 2 |
| | 5/16 x 1.00 Hex Screw | 11-3718 | 12 | 24 | 18. | Cover Assembly | 49-6787-2 | 1 | 2 |
| 2. | Power Lug | 80-4188 | 6 | 6 | | Cover Screw | 11-5394 | 2 | 4 |
| 3. | Stationary Contact | (See Item 35) | 6 | 12 | 19. | Molded Base | 49-6479 | 1 | 2 |
| 4. | Control Terminal | 80-4186 | 2 | 2 | 20. | Insulator | 56-6504 | 1 | — |
| 5. | Terminal Clamp | 55-1743 | * | * | 21. | Coil Terminal Clip | 80-2747 | 2 | 4 |
| 6. | Moveable Contact | (See Item 35) | 3 | 6 | 22. | Push Bar (L. Hand) | 61-1612 | 1 | 2 |
| 7. | Contact Spring | (See Item 35) | 3 | 6 | 23. | Armature | 48-1029-3 | 1▲ | 2▲ |
| 8. | Arc Chute | 62-905 | 6 | 12 | 24. | Indicator | 53-3050 | 1 | 2 |
| | #8-18 x .75 Thd. Cut. Screw | 11-3324 | 6 | 12 | 25. | Mounting Plate | — | 1 | 1 |
| | #8 Helical Washer | 16-42 | 6 | 12 | 26. | Bus Bars | 25-8031 | 1 | 1 |
| | #8 Flat Washer | 916-107 | 6 | 12 | 27. | Bus Bars | 25-8029 | 1 | 1 |
| 9. | Contact Bar | 23-6381 | 1 | 2 | 28. | Bus Bars | 25-8030 | 1 | 1 |
| | #10-32 x .938 Sems Screw | 11-3107 | 2 | 4 | 29. | Current Transformer | 42-3564-2 | 1 | 1 |
| | #10 Flat Washer | 916-166 | 4 | 8 | 30. | Mounting Plate | 17-18720 | 1 | 1 |
| | #10 Helical Washer | 916-484Z | 4 | 8 | 31. | Rubber Grommet | 29-1370-11 | 6 | 6 |
| 10. | Magnet Housing | 49-6742-2 | 1 | 2 | 32. | Bushing | 29-5785 | 6 | 6 |
| 11. | Magnet Spring | 69-2770 | 1 | 2 | 33. | Terminal Base Assembly | 10-6380-2 | 1 | 1 |
| 12. | Magnet Frame | 48-1030 | 1▲ | 2▲ | 34. | Overload Relay | C306DN3 | 1 | 1 |
| 13. | Magnet Retainer | 19-1570 | 1 | 2 | 35. | Renewal Contact Kit (Includes Items 3, 6, 7, & Mounting Hardware) | 6-45-2 | ** | ** |
| 14. | Magnet Coil | (See Table on Page 4) | 1 | 2 | | | | | |
| 15. | Spring | 69-2554 | 2 | 4 | | | | | |
| 16. | Push Bar (R. Hand) | 61-1606 | 1 | 2 | | | | | |

* As required.

▲ It is recommended that items 12 and 23 be replaced together.

** Recommended Spare Parts.

**ACCESSORIES
AUXILIARY CONTACTS, TERMINAL BLOCK
AND TRANSIENT SUPPRESSOR**

AUXILIARY CONTACTS

BASE MOUNTED

| Circuit | Catalog No. |
|---------------|-------------|
| 1 N.O. | C320KGS41 |
| 1 N.O.-1 N.C. | C320KGS42 |

FOR MOUNTING ABOVE BASE MOUNTED INTERLOCK

| Circuit | Catalog Number |
|---------------|----------------|
| 1 N.O. | C320KGS20 |
| 1 N.C. | C320KGS21 |
| 1 N.O.-1 N.C. | C320KGS22 |

TERMINAL BLOCK

| Catalog No. |
|-------------|
| C320TB2 |

TRANSIENT SUPPRESSOR

| Catalog No. |
|-------------|
| C320AS1 |

OPERATING COILS

| Volts | Hz. | Part No. | Volts | Hz. | Part No. |
|-------|-----|-----------|-------|-----|-----------|
| 120 | 60 | 9-1891-1 | 24 | 60 | 9-1891-15 |
| 110 | 50 | | | | |
| 240 | 60 | 9-1891-2 | 240 | 50 | 9-1891-20 |
| 220 | 50 | | | | |
| 480 | 60 | 9-1891-3 | 415 | 50 | 9-1891-21 |
| 440 | 50 | | | | |
| 600 | 60 | 9-1891-4 | | | |
| 550 | 50 | | | | |
| 208 | 60 | 9-1891-13 | | | |
| 380 | 50 | 9-1891-14 | | | |