

RENEWAL PARTS PUB - NEMA SIZE 3 NON-REVERSING AND REVERSING CONTACTORS AND STARTERS

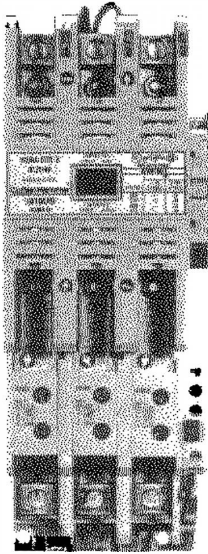

TYPICAL SIZE 3 STARTER

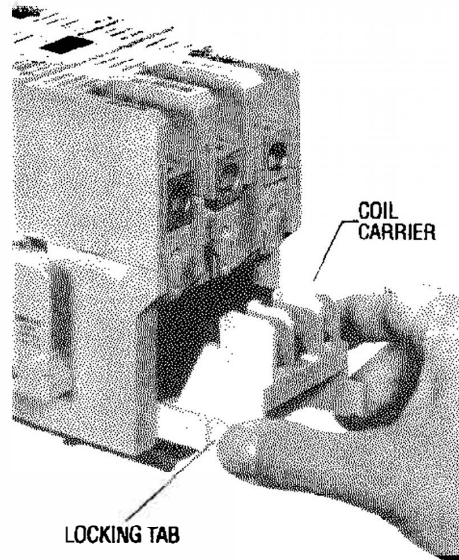

FIGURE 1 — COIL REMOVAL

INTRODUCTION

This publication is designed to simplify inspection and maintenance through the use of photographs and detail views for easy identification of parts. Illustrated steps on assembly and disassembly are shown. This information should be read carefully.

DESCRIPTION

This publication covers two and three pole, 3 phase reversing and non-reversing, NEMA type contactors and starters with ratings as shown on the nameplates.

CARE

These contactors / starters require no mechanical maintenance. All power contacts should be renewed at the same time before the contact tip material has worn away. Refer to Publication 14183 for helpful information on inspecting and determining when to replace the contacts. When renewing contacts, check all terminal screws to insure that they are tight and secure.



Disconnect power before any functions are performed on this equipment.

During routine electrical maintenance, the cover assembly should be removed to inspect the main contacts for wear. Please note Figure 4 exploded view drawing for service or repair.

MAIN COIL RENEWAL (Figure 1)

CAUTION: If the device has been in service, many parts may still be thermally hot.

1. Disconnect all power to the starter.
2. Depress the two locking tabs and slide coil carrier assembly out of contactor base.

NOTE: The contactor/starter may need to be removed from the enclosure in order to slide the coil carrier assembly completely out of the contactor base.

3. Remove old coil from coil carrier assembly and install new coil.
4. Insert coil carrier assembly back into contactor base, making sure that the locking tabs of the coil carrier assembly engage detents of contactor base.

MAIN COILS

Control Voltage		Main Coil Part No. (1 Reqd/Contactor)
Volts	Hertz	
110/120	50/60	9-2756-1
220/240	50/60	9-2756-2
440/480	50/60	9-2756-3
550/600	50/60	9-2756-4
208	60	9-2756-5
240	50	9-2756-13
277	60	9-2756-9
380	50	9-2756-12
415	50	9-2756-8
550	50	9-2756-14
24	50	9-2756-11
24	60	9-2756-6
32	50	9-2756-10
48	50	9-2756-7
48	60	9-2756-15

DC COILS*

Voltage	Main Coil Part No. (1 Reqd/Contactor)
12	9-3002-1
24	9-3002-2
48	9-3002-3
120	9-3002-4

*Must be used with C320KGD3 auxiliary contacts

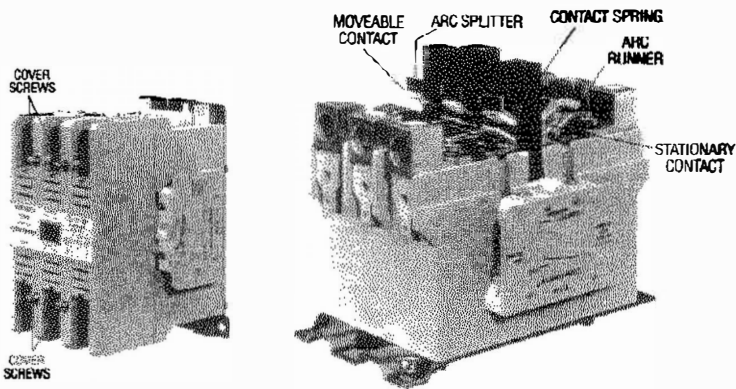

FIGURE 3 — OVERLOAD RELAY

MAIN CONTACT RENEWAL (Figure 2)

CAUTION: If the device has been in service, many parts may still be thermally hot.

Disassembly

1. Disconnect all power to the contactor/starter.
2. Loosen the four cover screws and remove cover assembly from the contactor.
3. **Movable Contacts** - Insert a small screwdriver into the contact spring and pry springs out of contact bar.
4. Lift up on arc splitters to disengage from contact bar detents and remove. Repeat step for movable contacts.
5. **Stationary Contacts** - Loosen screws that hold arc runners and stationary contacts and remove same from contactor.

Reassembly

6. Install new stationary contacts and arc runners onto contactor. Tighten screws to 14-18 lb-in. torque to insure proper operation.
7. Install new movable contacts and arc splitters into contact bar.
8. Compress contact springs between thumb and forefinger and insert springs so that springs engage detents of arc splitter and contact bar.
9. Install cover assembly onto contactor and tighten the four cover screws to 9-12 lb-in.

RENEWAL OF OVERLOAD (Figure 7)

The bimetal, ambient compensated overload relay is adjustable within the **FLA** range of the heater pack. Each heater pack is marked with its range of **FLA** ratings.

Select heater packs (**3 required**) according to the motor **FLA** rating, and install in overload relay. Rotate the **FLA** adjustment dial to a position corresponding to the motor **FLA**. **Consult overload relay publication supplied with the starter for proper setting and selection.** The overload relay is factory set for manual operation. If automatic reset is required, turn the reset adjustment dial to "A" or "AUTO".

THE ENTIRE OVERLOAD RELAY MUST BE REPLACED IF BURNOUT OF THE HEATER PACK OCCURS.

Do not disassemble the overload relay!

Lubrication

Do not lubricate any part of this equipment.

FIGURE 4

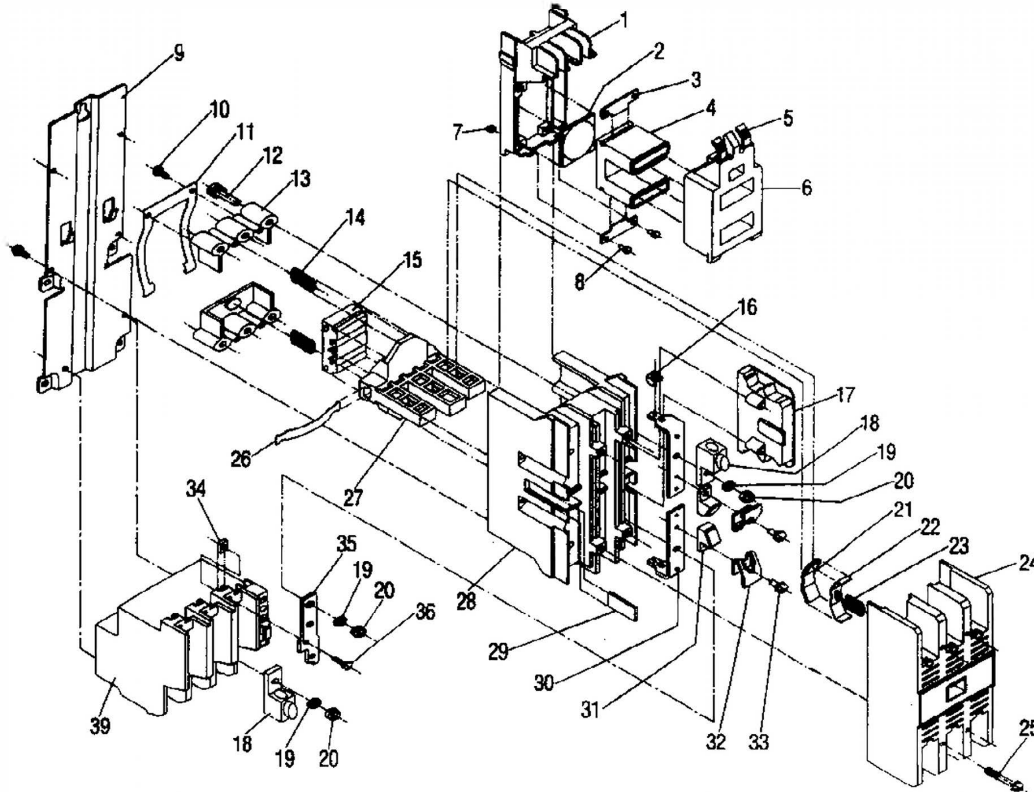

RENEWAL PARTS - Information Required

To insure prompt handling of renewal parts order, please include the following:

DESCRIPTION, PART NUMBER, AND QUANTITY REQUIRED

PARTS LIST

ITEM NO.	DESCRIPTION	PART NUMBER	QUANTITIES				ITEM NO.	DESCRIPTION	PART NUMBER	QUANTITIES			
			CN15	AN16	CN55	AN56				CN15	AN16	CN55	AN56
1	Coil Carrier	49-6758	1	1	2	2	24	Cover Assembly					
2	Shock Pad	32-1769	1	1	2	2		(3 Pole)	49-6867	1	1	2	2
3	Magnet Retainer	55-3656	2	2	4	4		(2 Pole)	49-6867-2	1	—	—	—
4	Magnet Frame	17-8955-2	1	1	2	2	25	Armature Spring	11-5359	4	4	8	8
5	Terminal Clamp	11-4825	2	2	4	4	26	Contact Carrier	69-4945	1	1	2	2
6	Magnet Coil	See Page 1	1	1	2	2	27	Housing	23-6621	1	1	2	2
7	6-32 Hex Nut	—	4	4	8	8	28	Insulator	49-6755	1	1	2	2
8	6-32 x .375 Sems Screw	—	4	4	8	8	29	Bus Bar	56-6504	1	1	—	—
9	Mounting Plant	—	1	1	1	1	30	(3 Pole)	80-6617	6	6	12	12
10	6-20x.375 Thread Forming Screw	11-5313	2	2	4	4		(2 Pole)	80-6617	4	—	—	—
11	Coil Flat Spring	69-4948	1	1	2	2	31	Stationary Contact	See Item 37	—	—	—	—
12	1/4-20x1.125 R.H. Screw	—	4	4	8	8	32	Arc Runner	See Item 37	—	—	—	—
	1/4" Lockwasher	—	4	4	8	8	33	Contact Mtg Screw	See Item 37	—	—	—	—
	1/4" Helical Washer	—	4	4	8	8	34	6-32 Square Nut	See Item 39	—	3	—	3
13	Spring Retainer	55-3612	2	2	4	4	35	Bus Bar	See Item 39	—	3	—	3
14	Return Spring	69-4946	2	2	4	4	36	8-32x.625 Sems Screw	See Item 39	—	3	—	3
15	Armature Assembly	48-1902	1	1	2	2	37	Renewal Contact Kit					
16	Control Wire Clamp	55-1743	3	3	3	3		(includes Items 21, 22, 23, 31, 32, 33)					
17	Auxiliary Contact	See Page 4	1	1	2	2		3 Pole	6-43-6	1	1	2	2
18	Power Lug (Cu)	80-3132	6	6	6	6	38	2 Pole	6-43-5	1	—	—	—
19	Power Lug (Al)	80-5484	6	6	6	6	39	Mechanical Interlock	C321KM30	—	—	1	1
20	1/4" Helical Washer	—	6	9	6	9		Overload Relay (includes Items 34, 35, 36, 39)	10-6530	—	1	—	1
21	Movable Contact	See Item 37	—	—	—	—							
22	Arc Splitter	See Item 37	—	—	—	—							
23	Contact Spring	See Item 37	—	—	—	—							

* It is recommended that Items 4 and 15 be replaced together.
 ** Recommended spare parts.

**ACCESSORIES
AUXILIARY CONTACTS, TERMINAL BLOCK,
AND TRANSIENT SUPPRESSOR**

Base Mounted

Circuit	Catalog No.
1 N.O.	C320KGS31
1 N.O. - 1 N.C.	C320KGS32

For Mounting Above Base Mounted Interlock

Circuit	Catalog No.
1 N.O.	C320KGS20
1 N.C.	C320KGS21
1 N.O. - 1 N.C.	C320KGS22
1 N.C. (DC coil)	C320KGD3

Transient Suppressor

Catalog No.
C320AS1

Terminal Block

Catalog No.
C320TB2