

EZD-XM-80

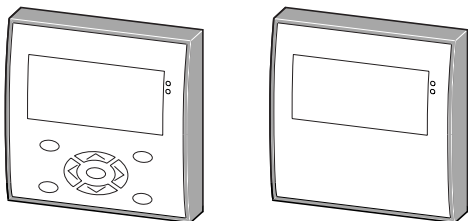

Dimensions – Dimensiones – Abmessungen – Dimensioni

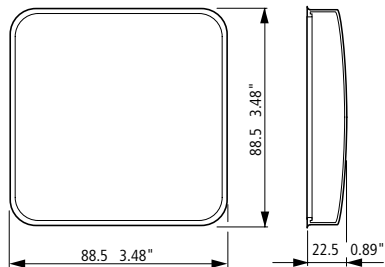

Diaphragm – Membrana – Calotte – Membrane – Membrana

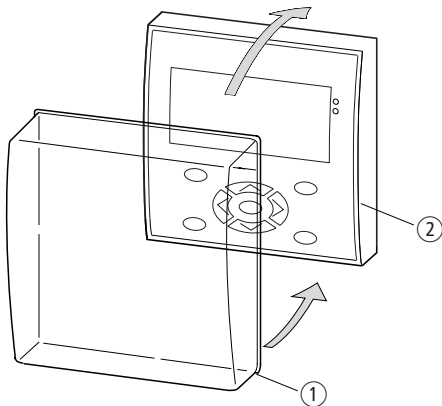

- ① EZD-XM-80
- ② EZD-80-(B)

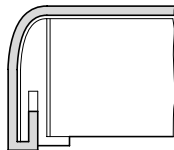

NEMA Type 4X

Caution!

Ensure that the membrane fits snugly in the groove of the display/operating unit.

Otherwise a proper seal cannot be guaranteed and particles may enter underneath the membrane. This may cause malfunctions in the keypad.

In food industry applications, there is the risk of bacteria building up underneath the membrane.

Eaton Electrical
1000 Cherrington Parkway
Moon Township, PA 15108
United States
tel. 1-800-525-2000
www.EatonElectrical.com

EATON

© 2005 by Eaton Corporation
All Right Reserved
Printed in the Federal Republic of Germany (Jan 2005)
Form No. IL05013012E
12276413/DE06 (Doku/)